

# INDEX

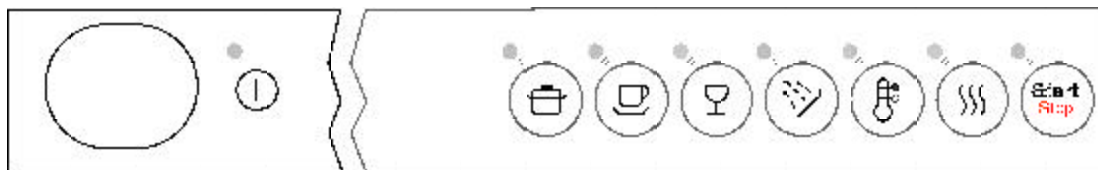

## D1796FI DISHWASHER (DW 95FI)

● PROGRAMS	2
● ELECTRICAL FUNCTIONS	5
● PART NUMBER SUFFIX DEFINITIONS	7
● SPARE PARTS LIST	
.. Casing and related parts	8
.. Container and related parts	10
.. Door	12
.. Control Panel	14
.. Dishwashing system	16
● WIRING DIAGRAM	18
● TIMER DIAGRAM	19
● SERVICE INFORMATION	
.. Air duct nozzle	20
.. Door springs	21
.. Water level	22
.. Door lock	23
.. Control unit failure analysis	24



## PROGRAMS

### PROGRAM

### DEFINITION

**Pots and pans**

Two prewashes, main wash, three rinses and drying.

**Normal**

Two prewashes, main wash, two rinses and drying.

**Quick**

One prewash, main wash, two rinses, heated drying.

**Rinse**

One rinse at 131°F (55°C). If Heat fan dry is selected, the heating element will activate. Drying: 158°F (70°C)

### OPTIONS

**Temperature**

Lets you select high or low water temperatures for the wash programs (except Rinse). (See the table below.) The indicator light glows when it's on the High setting and remains off when set on Low.

**Heat Fan Dry**

Pressing this touchpad activates the heating element along with the turbo fan for 12 minutes after the final rinse. (158° F/70° C)

**Start/Stop**

Press this touchpad to Start or Stop the machine. To interrupt a program, hold this touchpad down for three seconds.

## WASH PROGRAM TEMPERATURES

Wash Program	Temp	1st Prewash	2nd Prewash	Main Wash	1st Rinse	2nd Rinse	3rd Rinse
Pots & Pans/Sani	<b>Low</b>	113°F (45°C)	House	131°F (55°C)	House	House	131°F (55°C)
	<b>High</b>	113°F (45°C)	House	149°F (65°C)	House	House	149°F (65°C)
Normal	<b>Low</b>	86°F (30°C)	House	131°F (55°C)	House	131°F (55°C)	n/a
	<b>High</b>	86°F (30°C)	House	149°F (65°C)	House	149°F (65°C)	n/a
Quick	<b>Low</b>	House	n/a	113°F (45°C)	House	113°F (45°C)	n/a
	<b>High</b>	House	n/a	131°F (55°C)	House	131°F (55°C)	n/a

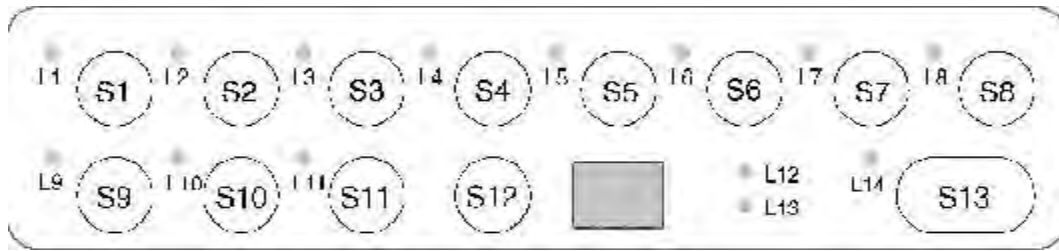

S = Pushbutton switch

L = Indicator light

## SETTING CHILD-SAFE START FUNCTION

The start function can be reprogrammed so that the button must be pressed in for 3 seconds to start the programs. To do this, **press S4 five times then press** one of the following:

- S5** to get a prolonged start function or
- S4** to get a normal start function.

## SETTING PUMP-OUT TIME

If it's necessary to reprogram the pump-out time, you can do so by **pressing S3 five times then pressing** one of the following:

<b>Press:</b>	<b>to get an outlet time of:</b>
<b>S3</b>	20 seconds
<b>S4</b>	25 seconds (factory setting)
<b>S5</b>	35 seconds
<b>S6</b>	45 seconds
<b>S7</b>	85 seconds

## SETTING INLET TIME

You can reprogram the inlet time on level controlled and time controlled inlets. To do this, **press S5 five times then press** one of the following:

<b>Press:</b>	<b>to get an inlet time of:</b>
<b>S3</b>	45 seconds (factory setting)
<b>S4</b>	56 seconds
<b>S5</b>	68 seconds
<b>S6</b>	90 seconds
<b>S7</b>	113 seconds
<b>S8</b>	180 seconds

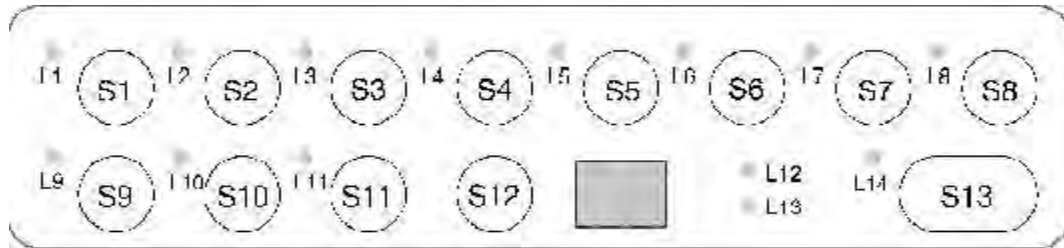

S = Pushbutton switch

L = Indicator light

## FAULT CODES

Blinking lights and an F-code in the LED window indicate a machine fault.

Code	Blinking Lights	Problem
F1	L3 and L7	Heating element
F2	L1-L8	Overfill
F3	L4 and L5	Thermistor fault (heater control)
F4	L1-L4	Water inlet

## FAULT-TRACING PROGRAM

The functions of the electrical components can be tested by **pressing S6 five times then pressing one** of the following:

Press	to test
S3	inlet valve 1
S4	combi-dispenser
S5	heating element
S6	circulation pump
S7	outlet pump
S8	fan motor and wax motor

Stop the fault-tracing program by pressing S13.

## LINKS ON THE PROCESSOR BOARD (for program variations)

These diodes should be cut for proper U.S. installation:

Link 953: D1796 processor board layout

Link USA: USA processor board layout

**CONTROL PANEL (see page 15)**

The control panel contains a microprocessor for control of programs, circulation pump, inlet valves, etc. It also allows for custom settings of programs (see page 3).

**CIRCULATION PUMP/MOTOR (see page 17)**

The circulation pump/motor consists of a synchronous motor and pump, constructed in an integrated unit. A 16  $\mu$ F capacitor is fitted to the circulation motor/pump.

**OUTLET PUMP (see page 17)**

The outlet pump consists of a synchronous motor and pump, constructed in an integrated unit.

**INLET VALVE (see page 17)**

A single-unit type: A solenoid and valve seat.

**HEATING ELEMENT (see page 11)**

1400 Watt

**THERMISTOR (see page 11)**

The thermistor controls the water temperature within  $\pm 1^{\circ}\text{C}$  ( $2.5^{\circ}\text{F}$ ) to give the required temperature. The heater will be disconnected if the thermistor is short-circuited or loosened from the circuit board and the fault code "F3" displays in the LED window. The normal resistance of the thermistor is between 25 and 15K ohm at  $68^{\circ}\text{F}$  ( $20^{\circ}\text{C}$ ) or  $86^{\circ}\text{F}$  ( $30^{\circ}\text{C}$ ) alternately.

**OVERHEAT PROTECTION (see page 11)**

The thermostat has a switch-off function at  $190^{\circ}\text{F}$  ( $88^{\circ}\text{C}$ ) that prevents the heating element from staying on if the control unit or the timer should fail.

**DOOR SWITCH (see page 17)**

A microswitch senses that the door has been opened. This interrupts the program and cuts the power to all control components (motor, valves, etc.).

**LEVEL SWITCH (PRESSURE SWITCH) (see page 11)**

This switch protects against overfilling by interrupting the power to the inlet valve and starting the outlet pump. If the water level has not dropped within 30 seconds or if overfill has occurred twice during the same program, the program will be terminated and a fault code displays. The overfill protection operates during all programs, including fault-tracing, even if the microprocessor is faulty.

**OVERFILL SWITCH (see page 11)**

A float in the base pan influences a microswitch that disconnects the inlet valve and starts the outlet pump.

**COMBI-DISPENSER (see page 13)**

The combi-dispenser dispenses both detergent and rinse aid. The dispenser has an adjustable volume chamber for setting the desired amount of rinse aid.

**TURBO FAN (see page 13)**

The turbo fan evacuates the moist air from the machine during the drying phase of the program. The fan system consists of a fan motor that runs a two-part impeller. Dry, cool air is pulled in from the door into one of the impeller halves. A wax motor opens a damper and the moist air is pulled into the other part of the impeller. The dry, cool air and warm, moist air mix and condense in the condensation chamber. The condensed moisture then drains through the channel to the lower sump area. Dry air is then vented out through a channel below the outer door.

**ELECTRICAL SUPPLY**

The machines are wired for connection to a single-phase, 120V, 15A supply, with a heater power of 1400W, giving a total power requirement of 1600W.

**VALUES FOR WIRING DIAGRAMS**

Resistance values at 68° F (+/-5°F), 20° C (+/-3°C)

(Values within +/- 10% is normal.)

AP	Drain pump	120V, 60 Hz, 25.5 ohm
BB	Illumination switch	
CP	Main pump	120 V, 60 Hz, Main = 10.5 ohm, Aux = 14.5 ohm
KD	Combi-dispenser	120 V, 0.31 ohm
EL	Heating element	120 V, 1400 W, 10 ohm
IV	Inlet valve	120 V, 9.93 K ohm (1-3, 2-4)
FL	Fan	120 V, 0.25 K ohm
LB	Door switch	
LU	Door	
N	Level switch	
NTE	Level thermistor	2.4 K ohm
P	Control unit	
T	Thermostat	19–25 K ohm
TB	Pushbutton switch	
TTE	Temp. thermistor	19–25 K ohm
WAX	Wax motor	1.5–3.0 K ohm
VMG	Rinse ag sensor	
OB	Overflow switch	

The lists below define the meanings of the dashed numbers or letters following a part number:

**Colors:**

- 0 White
- 29 Black, bright
- 33 Black
- 36 Dark grey
- 49 Helios grey
- 69 black, metallic
- 77 grey
- 81 metallic
- 95 Stainless Steel

**Note:** Not all colors are available for all parts.

**Doors**

- M for units with fan
- P for integrated units
- R for decor frames, long deviation
- S for decor frames, short deviation
- T for decor frames with adjustable lower part



Model D1796FI  
(DW 95FI)

Date 2000-06	<b>CASING AND RELATED PARTS</b>	Page <b>8</b>
-----------------	---------------------------------	------------------



Date		<b>CASING AND RELATED PARTS</b>			Page
2000-06					9
Fig.	Qty	Part No.	Description	Notes	
1	1	80 583 53	Sound insulation		
2	1	80 600 41	Sound insulation profile		
3	1	80 575 26	Guard plate		
	4	89 003 52	Screw	RTS ST 4.2x13	
4	1	80 600 87	Felt, kick plate		
5	1	80 575 28-	Kick plate, low	-0, -81	
	1	80 575 29-	Kick plate, high	-0, -81	
	2	89 009 44-	Screw, kick plate	-0, -29	
9	1	80 584 86	Drip protection for guard plate		
10	2	80 575 49	Bracket, kick plate		
11	2	80 575 50	Spring, kick plate		
	2	89 003 27	Screw	RTS ST 4.2x13 FZB T20	

Date <b>2000-06</b>	<b>CONTAINER AND RELATED PARTS</b>	Page <b>10</b>
------------------------	------------------------------------	-------------------

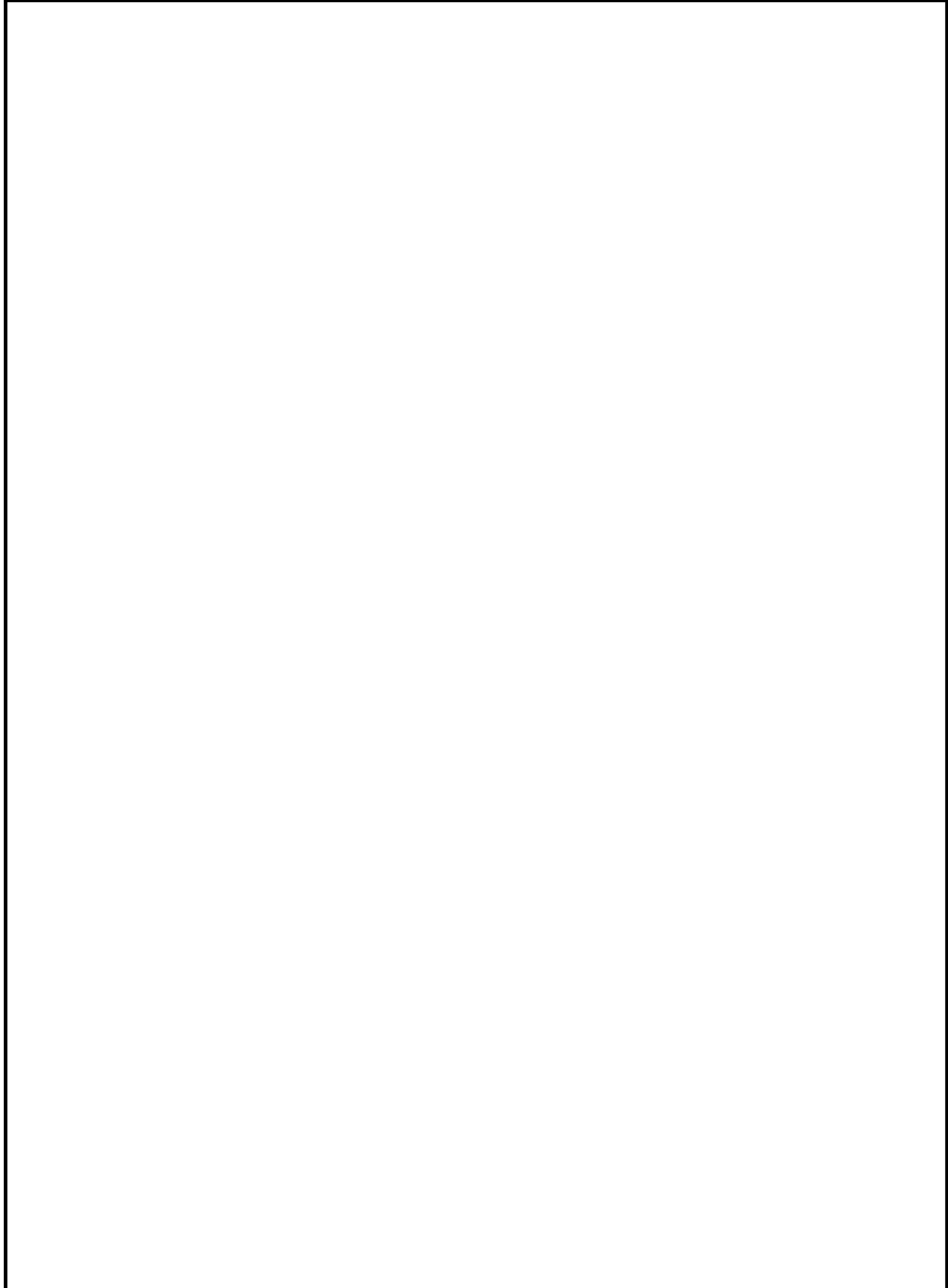

Date		CONTAINER AND RELATED PARTS		Page
2000-06				11
Fig.	Qty	Part No.	Description	Notes
2	1	80 706 13	Sealing strip, casing top	
	1	80 600 65	Sealing strip, left	
	1	80 600 66	Sealing strip, right	
	2	80 600 38	Sound insulation, bottom outer	
3	1	80 574 89	Tub seal	
4	2	80 579 78-	Ball catch	-77
5	2	80 586 38-	Ball holder, guide rail	-77
6	8	80 579 77	Ball bearings	
7	2	80 579 79-	Basket stop	-77
8	2	80 570 52	Guide rail	
9	1	80 600 33	Sound absorb. slab,	
10	4	89 011 10	Screw + o-ring	A2-M6x12 T30
11	1	80 570 77	Heating element	1400 W
	1	80 602 58	Cable holder, for heating element	
	2	80 023 70	Protection collar, heating	
12	1	80 584 95	Cable holder, door	
14	1	80 701 42	Cable holder	
15	1	80 025 79	Thermostat	Overheat protection
17	2	80 706 14	Sealing strip	
18	1	80 575 23	Bottom outer (base pan)	
	2	89 011 04	Screw	A2-MRT-TT 4x8 T20 FZB
19	2	80 584 91-	Door spring, compl.	-77
	2	80 602 32-	Door spring, compl.	-77 For wood panel
	2	80 713 23-	Door spring, compl.	-77, heavy duty
20	1	80 704 95	Mount, inlet valve	
	2	89 003 27	Screw	RTS ST 4.2 x 13 FZB T20
21	1	80 602 55	Mount, electrical connection	
22	1	80 599 91	Cable holder	
23	1	80 069 48	Grommet	
24	1	80 585 58	RFI filter	
25	1	80 502 51	Terminal block	3-pole
	1	89 003 57	Screw, terminal block	RTS ST 4.2x25 FZB T20
	1	89 021 31	Screw, grounding terminal block	MRT-TT 4x6 FZB T20
	1	89 014 13	Washer	AZ4.3 FZB
26	4	80 721 19	Reinforcement washer	
27	4	80 570 62	Leveling leg	M10x100, 8.8 FZB
28	4	89 011 56	Nut	M6M10 BH8 FZB
29	2	80 519 57	Slide foot, rear only	

Date 2000-06	<b>DOOR</b>	Page 12
-----------------	-------------	------------

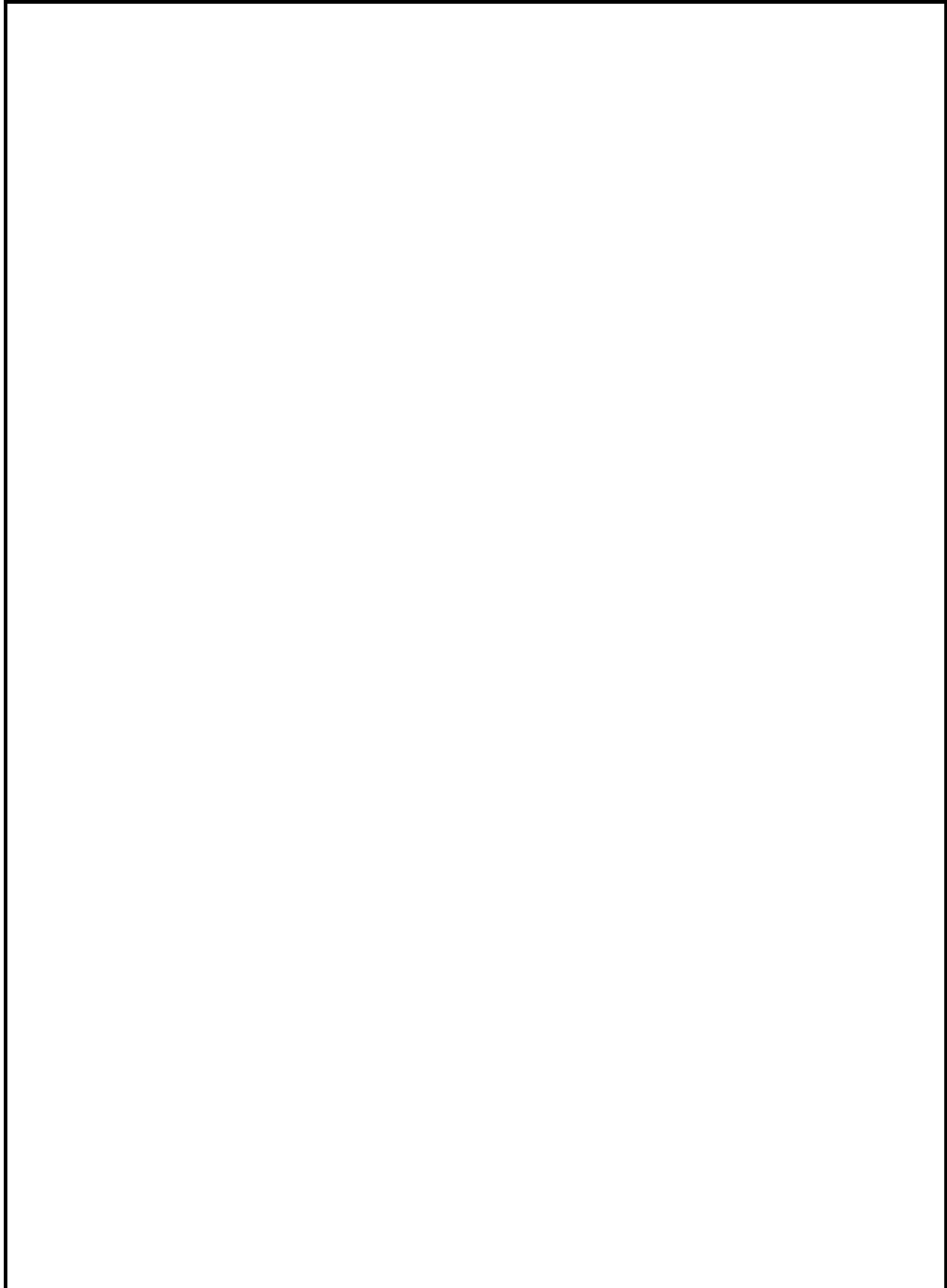

Date				Page
2000-06		<b>DOOR</b>		<b>13</b>
Fig.	Qty	Part No.	Description	Notes
1	1	80 600 21	Fan, compl.	
2	1	80 527 78	Wax motor	
3	1	80 585 01	O-ring	84.5x3
4	1	80 579 63-	Air channel	-P
5	1	80 722 97	Nozzle for air channel	(See page 18)
6	1	80 722 98-	Strut for nozzle	-29
7	1	88 011 20	Inner door	
	4	89 021 20	Screw	A2-MKFT 5x10-TT FZB
8	1	80 579 64	Lock ring, fan casing	
9	1	80 584 84	Cover plate, fan	
	2	89 020 85	Screw	A2-PTK 40x10 WN1452 TT
10	1	88 011 40-	Combi-dispenser	-77
	6	89 020 87	Screw	PTK 40x14 WN1452 FZB
	1	80 719 17	Rinse aid cap	
	1	80 719 18	Combi-dispenser lid	incl. seal and spring
11	1	80 575 25	Hinge, left	
	1	80 575 24	Hinge, right	
	2	80 575 30	Hinge screw	
	2	33500262	Nut, hinge bearing	Locking 4 BH8 FZB
12	2	80 579 48	Slide washer, hinge bearing	
13	1	80 715 87	Holder, cable harness	
	1	89 021 31	Screw	MRT-TT 4x6 FZB T20
14	1	80 602 54	Door seal, lower	
15	1	80 579 85	Brace stand	
	2	89 006 46	Screw	A4 RTS 4.2x13 T20
18	1	80 579 86-	Door, outer part	-PT-0, -81
	6	89 006 46	Screw	A4 RTS 4.2x13 T20
	2	89 003 27	Screw	RTS ST 4.2x13 FZB T20
	2	80 703 50-	Plug	-0, -33
19	1	80 702 94	Sound insulation	
20	1	80 703 63	Adjusting frame complete	

Date

2000-06

**CONTROL PANEL**

Page

14

Date		CONTROL PANEL		Page
2000-06				15
Fig.	Qty	Part No.	Description	Notes
1	1	80 708 83-	Panel	-81, Assembly instructions
2	1	80 706 50	Spring	
3	1	80 706 44-	Pushbutton	-81
4	1	80 706 43-	Main switch casing	-81
5	1	80 575 47	Main switch	
6	1	80 710 77	Hose	9x13x295
7	1	80 706 47	Lock casing	
8	1	80 706 45-	Masking	-77
9	1	80 706 48	Lock washer	
10	1	80 706 49	Lock catch	
	1	89 011 04	Screw	A2-MRT-TT 4x8 T20
11	1	80 710 49	Protective film	
12	1	88 012 03	Control unit	
	1	80 600 76	Contact cover	
	2	89 020 53	Screw	PTK 40x45/15 FZB
	2	89 020 87	Screw	PTK 40x14 WN1452 FZB
13	1	80 706 41	Handle	
	2	89 020 87	Screw	PTK 40x14 WN1452 FZB
14	1	80 734 07-	Decor insert	-81
	4	80 729 66	Spacer	
15	1	80 706 40-	Panel	-81
	2	89 020 85	Screw	A2-PTK 40x10 WN1452
16	1	80 597 67	Thermistor	
17	1	80 734 47	Cable harness complete	
	1	80 730 96	Use and Care Guide	

Date 2000-06	<b>DISHWASHING SYSTEM</b>	Page <b>16</b>
-----------------	---------------------------	-------------------

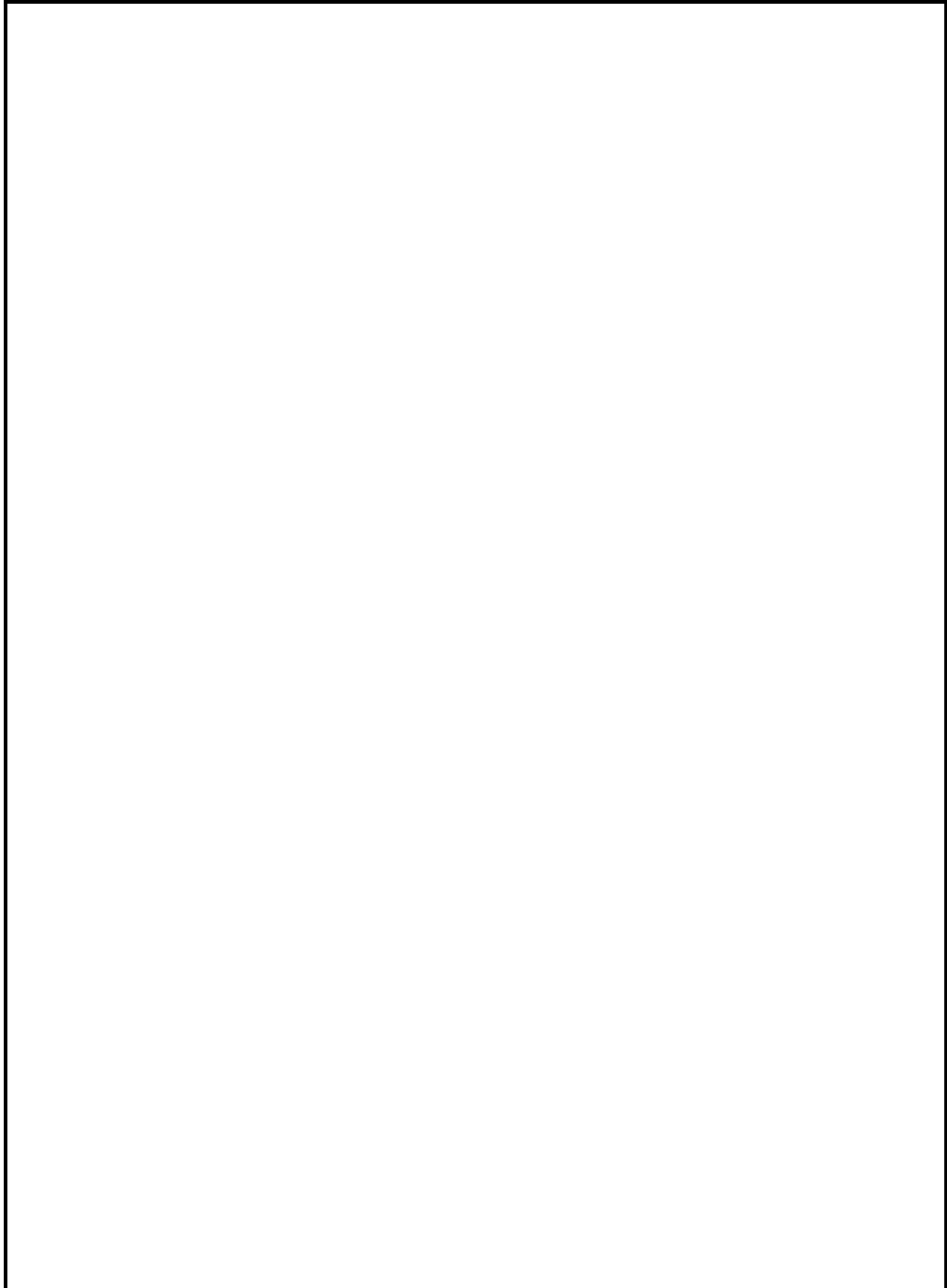



Date		<b>DISHWASHING SYSTEM</b>		Page
2000-06				17
Fig.	Qty	Part No.	Description	Notes
1	1	80 713 37-	Cup shelf, wine glasses	-36
2	1	80 011 99-	Upper basket, w/wheels *	-36, with cup shelf
3	1	80 713 36-	Cup shelf	-36
4	1	80 575 36-	Lock ring, air break	-77
5	1	80 585 04	O-ring, inlet air break	
6	1	80 575 14	Air break	
7	1	80 597 40	Strainer, upper part	
8	4	80 584 98-	Basket wheel, upper	-77
9	1	80 575 06-	Knife stop, upper basket	-77
	2	80 712 14-	Knifestand, upper basket	-77
10	1	88 010 89-	Cutlery basket	-77
11	1	88 012 00-	Lower basket	-36
12	8	80 095 16-	Basket wheel, lower	-77
13	1	80 584 93-	Lower basket insert	-36
14	1	80 703 04	Outlet hose	
15	1	80 726 95	Spray arm, upper	
16	2	89 012 62	Nut, spray arm bearing	
17	2	80 520 95	Washer, spray arm bearing	
18	2	80 570 70-	Spray arm bearing	-77
19	1	80 570 68-	Spray pipe bearing, upper	-77
20	1	80 570 63	Spray pipe	
21	2	80 521 89	Hose clip, inlet valve	17.0-706
22	1	80 585 02	Rubber hose, inlet valve	
23	1	80 721 21	Inlet valve	
	2	89 020 87	Screw	PTK 40x14 WN1452 FZB
24	1	80 726 92	Spray arm lower	
25	1	80 570 67-	Spray pipe bearing, lower	-77
26	1	89 017 55	O-ring, lower spray pipe bearing	
27	1	80 570 69	Nut, spray pipe bearing	
28	2	80 574 84	Hose, circulation pump	
29	4	80 520 97	Hose clip, circ. pump hose	44.0-708
30	1	80 550 95	Rubber buffer, circ. pump	
31	1	80 710 24	Level switch (pressure)	
32	1	80 570 53	Float, base pan	
33	1	80 600 68	Microswitch float	
34	1	80 585 00	Rubber hose	5x8x340
35	1	88 011 23-	Bottom well, sump	-77
36	1	80 585 03	O-ring, bottom well, sump	109.5x3
37	1	80 574 87-	Cover plate	-33
38	1	80 025 84	O-ring, outlet pump	49.5x3
39	1	80 720 32	Outlet pump	
40	1	80 522 39	Hose clip	31.6-708
41	1	80 574 88	Lock ring, bottom well, sump	
42	1	80 584 54	Cover plate	
43	1	80 579 72-	Filter basket, coarse	-77
44	1	80 574 86-	Insert, filter basket	-77
45	1	80 712 50	Circulation pump	

\*When ordering an upper basket, you also need to order the knife stop and knife stand (see Figure 9).



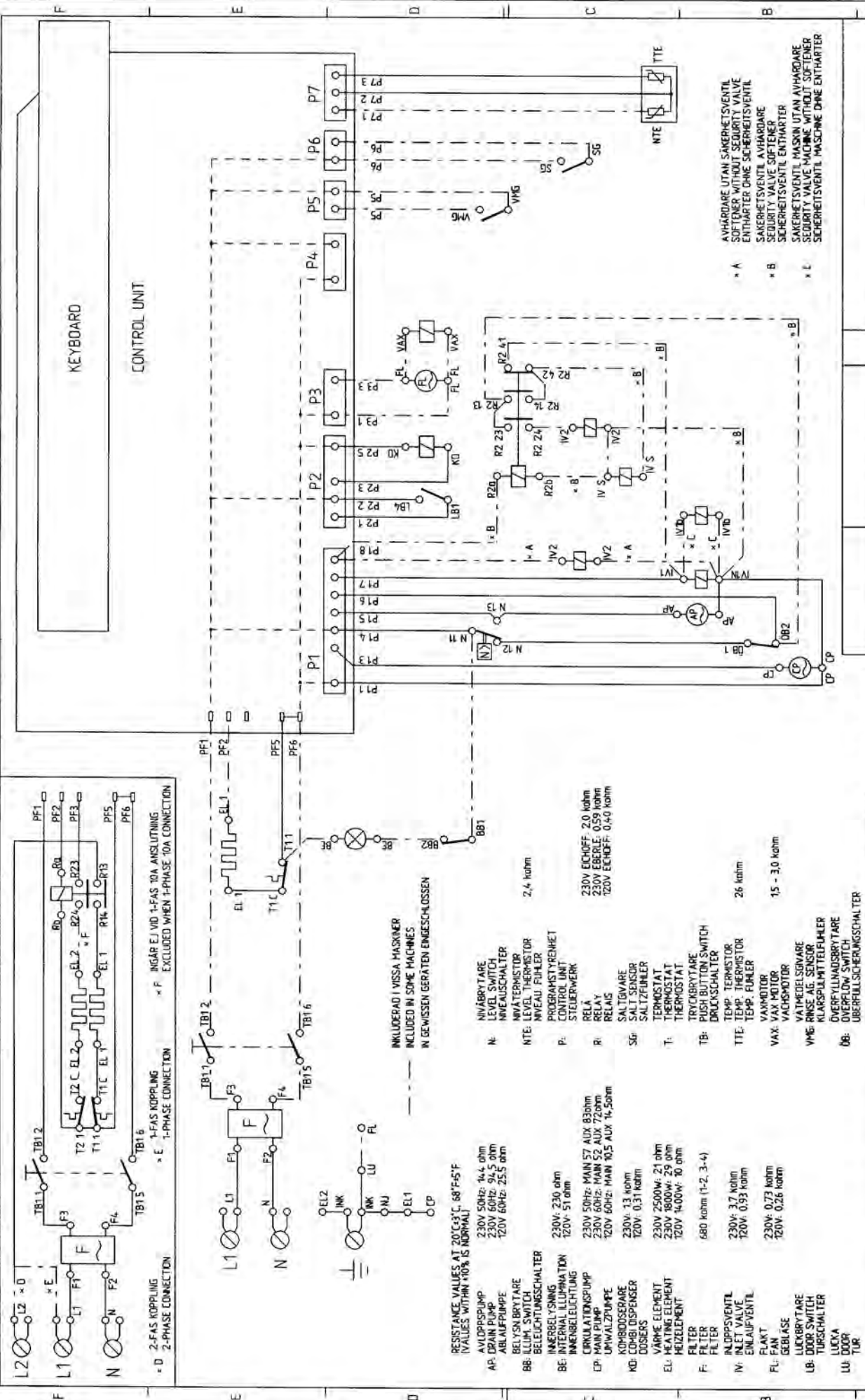

RESISTANCE VALUES AT 20°C/68°F: 68 F/5°F  
VALUES WITHIN 10% IS NORMAL

AV: DISPPUMP	230V 50Hz: 4-4 ohm
AP: DRAIN PUMP	230V 60Hz: 94.5 ohm
AB: ABLAUFpumpe	120V 60Hz: 25.5 ohm
BE: BELYSN BRYTARE	230V 230 ohm
BE: BELEUCHTUNGSSCHALTER	120V 51 ohm
BE: INNERBELYSNING	230V 230 ohm
BE: INTERNAL ILLUMINATION	120V 51 ohm
CP: CIRCULATIONSPUMP	230V 50Hz: MAIN 57 AUX 83 ohm
CP: MAIN PUMP	230V 60Hz: MAIN 52 AUX 72 ohm
CP: UPMWALZpumpe	120V 60Hz: MAIN 10.5 AUX 14.5 ohm
KD: KOMBI-DISPENSER	230V 13 kohm
DO: DOSERS	120V 0.31 kohm
EL: VÄRME ELEMENT	230V 2500W: 21 ohm
EL: HEATING ELEMENT	230V 1800W: 29 ohm
HE: HEIZELEMENT	120V 1400W: 10 ohm
FL: FILTER	680 kohm (1-2, 3-4)
FL: FILTER	230V 3.7 kohm
FL: FILTER	120V 0.93 kohm
IN: INLETT VALVE	230V 0.73 kohm
EN: ENLAUPVENTIL	120V 0.26 kohm
FL: FLAKT	230V 0.73 kohm
FAN: GEBLÄSE	120V 0.26 kohm
LU: LUCKBRYTARE	
LU: LOCK SWITCH	
TU: TURSCHALTER	
LU: LUCKA	
TU: TUR	

INKLUDERAD I VISSA MASKINER  
INCLUDED IN SOME MACHINES  
IN BEWISSEN GERÄTEN ENGESCHLOSSEN

05 Resistansvärden inf. ML 97 42  
04 Koppl. innerbelysn. mod. ML 97 36  
03 Koppl. xF: 1-fas 10A inf. ML 95 48  
02 Ny kopl. avh m säkerh. ML 95 13  
01 Koppl. utan 1/0-bryt. inf ML 95 06  
01 ml.ventil avh. m. säk. inf ML 95 06

Rev ind | Revision | 80 584 83-05

Article No.	Name of item	Qty	Material,dimensions,type,etc.
97 42	ML		
97 36	ML		
95 48	ML		
95 13	ML		
95 06	inf ML		
95 06	inf ML		

Scale: Gen: tolerance  
 Drawn by: ML  
 Designed by: ML  
 Checked by: ML  
 Completed by: ML

Rev ind | Year | Week | Replaced by

80 584 81 | 05 | Replaced by 8058481-04

1 | 2 | 3 | 4 | 5 | 6 | 7 | 8 | 9 | 10 | 11 | 12 | 13 | 14 | 15 | 16 | 17 | 18 | 19 | 20

1 | 2 | 3 | 4 | 5 | 6 | 7 | 8 | 9 | 10 | 11 | 12 | 13 | 14 | 15 | 16 | 17 | 18 | 19 | 20

1 | 2 | 3 | 4 | 5 | 6 | 7 | 8 | 9 | 10 | 11 | 12 | 13 | 14 | 15 | 16 | 17 | 18 | 19 | 20

1 | 2 | 3 | 4 | 5 | 6 | 7 | 8 | 9 | 10 | 11 | 12 | 13 | 14 | 15 | 16 | 17 | 18 | 19 | 20

Product: DW95FI

Date: 99-03-26

**TOPIC: AIR DUCT NOZZLE**

A new plastic nozzle has been developed to reduce problems with condensation from the fan nozzle on our fully integrated machines. These parts can also be fitted to previously manufactured models.

New Part Numbers: 80 722 97 Nozzle for air duct  
80 722 98-29 Strut for nozzle

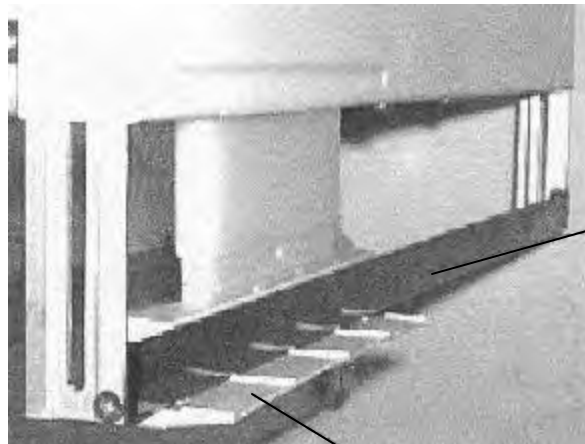

80 722 98-29

80 722 97

The following parts have been discontinued:

80 583 63	Adjustment frame, bottom section
80 708 01	Vapor barrier for wood door
80 598 80	Nozzle for air duct
80 598 91-77	End plug, left
80 598 92-77	End plug, right
80 584 87	Strut for air duct

Date  
**2000-06****SERVICE INFORMATION**Page  
**19**

Product: DW95

Date: 98-03-12

**TOPIC: DOOR SPRINGS**

There are three different sets of door springs, as defined below:

<b>Part Number</b>	<b>Machine</b>	<b>Weight Capacity</b>	<b>Color Coding</b>
80 584 91-77	For all standard machines	9 lbs.	none
80 602 32-77	For integrated and fully-integrated machines	12 lbs.	yellow
80 713 23-77	Heavy-duty for wooden panels, available as accessory part	22 lbs.	red



Color code

Product: DW95

Date: 98-03-13

**TOPIC: WATER LEVEL**

Switch level transferred to measuring points on the coil arm bearing.

**Timer-controlled machines**

Water flow inlet valve = 3.8 +/- 5% ltr / min

Intake time = 60 seconds

- Max. tol. 3.8 +5% = 3.9 ltr    +3 mm
- Max. tol. 3.8 +/- 5% = 3.9 ltr    +2 mm
- Max. tol. 3.8 -5% = 3.9 ltr    +1 mm

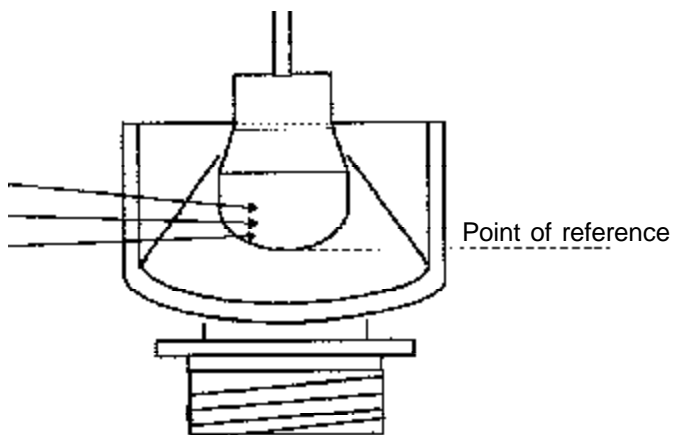

**Electronic machines**

Water flow inlet valve = 3.8 +/- 5% ltr / min

Intake time = 57 seconds

- Max. tol. 3.8 +5% = 3.7 ltr    +1 mm
- Max. tol. 3.8 +/- 5% = 3.51 ltr    +0 mm
- Max. tol. 3.8 -5% = 3.3 ltr    -1 mm

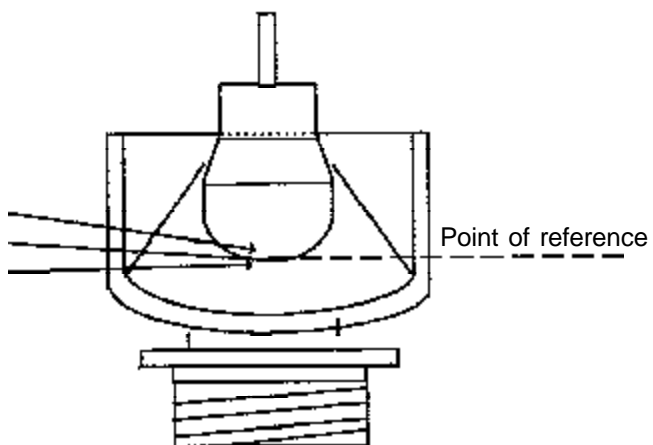

**Note:** Start with dry bottom well, which gives a 2mm lower level.

Date  
**2000-06****SERVICE INFORMATION**Page  
**21**

Product: DW95

Date: 98-03-13

**TOPIC: GUIDE PIN FOR DOOR LOCK**

Occasionally, the guide pin for the door lock may freeze or become stuck, causing the machine not to stop when the door is opened. To prevent this, you can lubricate the guide pin with petroleum jelly.

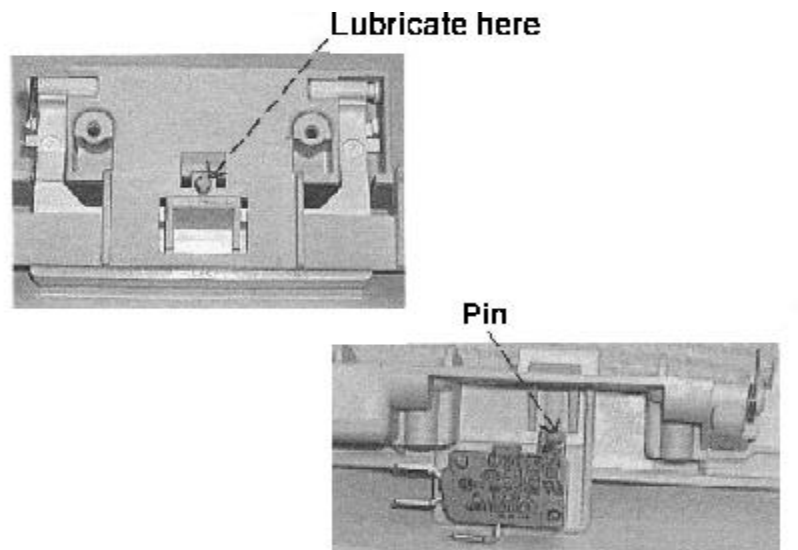

Date <b>2000-06</b>	<b>SERVICE INFORMATION</b>	Page <b>22</b>
------------------------	----------------------------	-------------------

Product: DW95

Date: 98-03-13

**TOPIC: CONTROL UNIT FAILURE ANALYSIS**

To prevent repeated exchanges of control units due to failures in auxiliary components (circulation pumps, inlet valves, etc.), a simple check on the control unit should be done to determine what cause the failure.

If any of the control unit components listed below or the conductive pattern (copper foil on the soldering side) near these components are damaged, most likely the external component caused the failure and should be ohm-measured. In the case of short-circuits, the components should be exchanged along with the control unit.

<b>External Component</b>	<b>Associated Output Components</b>
Heater	K1, PF2
Drain pump	K2, P1 5
Circulation pump	K3, P1 3
Inlet valve 1	Q13, R36, R52, D22, D24, P1 7
Combi-dispenser	Q12, R50, R58, D21, D23, P2 3
Fan and wax motor	Q16, R46, R56, D18, D19, P3 3
Interior light	P4 3 (after 9740, the lamp is not connected to the control unit.)

K=Relay  
Q=Triac  
R=Resistor  
D=Diode  
P=Connector

**Note:** Once the wax motor has dried out, it is not possible to measure for faults. Remove the wax motor and check for burn marks. For complete certainty, replace the wax motor.