

INDEX

D1706 AND D1716 DISHWASHERS (DW952)

● PROGRAMS	2
● ELECTRICAL FUNCTIONS	4
● PART NUMBER SUFFIX DEFINITIONS	6
● SPARE PARTS LISTS	
.. Casing and related parts	8
.. Container and related parts	10
.. Door	12
.. Control panel	14
.. Dishwashing system	16
● WIRING DIAGRAM	18
● TIMER DIAGRAM	19
● SERVICE INFORMATION	
.. Door springs	20
.. Water level	21
.. Door lock	22

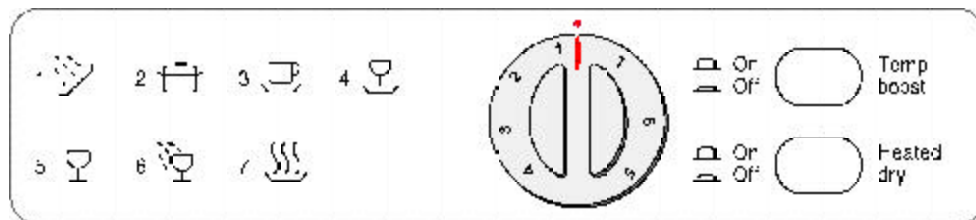

PROGRAMS

PROGRAM	DEFINITION
Rinse and hold	One rinse without heat.
Pots and pans	Three prewashes, main wash, two rinses and drying.
Normal	Two prewashes, main wash, two rinses and drying.
Light	One prewash, main wash, two rinses and drying.
Quick	Main wash, two rinses, heated drying.
Rinse	One rinse at 140°F (60°C) and heated dry.
Plate warm	One drying sequence.

OPTION BUTTONS

Temp Boost	Lets you select high or low water temperatures for the main wash and final rinse. (See the table below.)
Heated Dry	Releasing this button activates the heating element for 12 minutes after the final rinse. (158°F/70°C)

WASH PROGRAM TEMPERATURES

Wash Program	Temp Boost	1st Prewash	2nd Prewash	3rd Prewash	Main Wash	1st Rinse	2nd Rinse
Pots & Pans	Off	House	86° F (30°C)	House	House	House	House
	On	140°F (60°C)	86° F (30°C)	House	140°F (60°C)	House	140°F (60°C)
Normal	Off	86°F (30°C)	House	n/a	House	House	House
	On	86°F (30°C)	House	n/a	140°F (60°C)	House	140°F (60°C)
Light	Off	House	n/a	n/a	House	House	House
	On	House	n/a	n/a	140°F (60°C)	House	140°F (60°C)
Quick	Off	n/a	n/a	n/a	House	House	House
	On	n/a	n/a	n/a	140° F (60°C)	House	140°F (60°C)

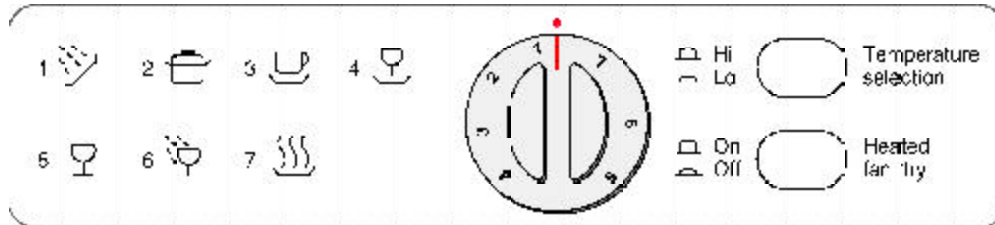

PROGRAMS

PROGRAM	DEFINITION
Rinse and hold	One rinse without heat.
Pots and pans	Three prewashes, main wash, two rinses and drying.
Normal	Two prewashes, main wash, 2 rinses and drying.
Light	One prewash, main wash, two rinses and drying.
Quick	Main wash, two rinses, heated drying.
Rinse	One rinse and heated dry. Rinse: 140°F (60°C). Drying: 158°F (70°C)
Plate warm	One drying sequence.

OPTION BUTTONS

Temperature Selection	Lets you select high or low water temperatures for the main wash and final rinse. (See the table below.)
Heated Fan Dry	Releasing this button activates the heating element for 12 minutes after the final rinse. (158°F/70°C)

WASH PROGRAM TEMPERATURES

Wash Program	Temp Boost	1st Prewash	2nd Prewash	3rd Prewash	Main Wash	1st Rinse	2nd Rinse
Pots & Pans	Lo	131°F (55°C)	86°F (30°C)	House	131°F (55°C)	House	131°F (55°C)
	Hi	149°F (65°C)	86°F (30°C)	House	149°F (65°C)	House	149°F (65°C)
Normal	Lo	86°F (°30C)	House	n/a	131°F (55°C)	House	131°F (55°C)
	Hi	86°F (°30C)	House	n/a	149°F (65°C)	House	149°F (65°C)
Light	Lo	House	n/a	n/a	131°F (55°C)	House	131°F (55°C)
	Hi	House	n/a	n/a	149°F (65°C)	House	149°F (65°C)
Quick	Lo	n/a	n/a	n/a	131°F (55°C)	House	131°F (55°C)
	Hi	n/a	n/a	n/a	149°F (65°C)	House	149°F (65°C)

Date 2000-06	ELECTRICAL FUNCTIONS	Page 4
<p>CONTROL TIMER (see page 15) Models D1706 and D1716 have electro-mechanical timers.</p> <p>CIRCULATION PUMP/MOTOR (see page 17) The circulation pump/motor consists of a synchronous motor and pump, constructed in an integrated unit. A 16 μF capacitor is fitted to the circulation motor/pump.</p> <p>OUTLET PUMP (see page 17) The outlet pump consists of a synchronous motor and pump, constructed in an integrated unit.</p> <p>INLET VALVE (see page 17) A single-unit type: A solenoid and valve seat.</p> <p>HEATING ELEMENT (see page 11) 1400 Watt</p> <p>THERMOSTATS (see page 11)</p> <p>140°–127°F (60°–52°C) (Model D1706 only) This thermostat has two switch-off functions with the temperatures 140°F (60°C) (reset at 133°F/56°C) and 127°F (53°C) (reset at 113°F/45°C) for temperature stop in prewash or drying, respectively.</p> <p>147°–127°F (64°–53°C) (Model D1716 only) This thermostat has two switch-off functions with the temperatures 147°F (64°C) (reset at 133°F/56°C) and 127°F (53°C) (reset at 113°F/45°C) for temperature stop in main wash and last rinse.</p> <p>140°–127°F (60°–52°C) (Model D1716 only) This thermostat has two switch-off functions with the temperatures 147° F (64°C) (reset at 133°F/56°C) and 127°F (53°C) (reset at 113°F (45°C) for temperature stop in main wash and last rinse.</p> <p>OVERHEAT PROTECTION (see page 11) The thermostat has a switch-off function at 190° F (88°C) that prevents the heating element from staying on if the control unit or the timer should fail.</p> <p>DOOR SWITCH (see page 17) A microswitch senses that the door has been opened. This interrupts the program and cuts the power to all control components (motor, valves, etc.).</p> <p>LEVEL SWITCH (PRESSURE SWITCH) (see page 11) This switch provides protection against overfilling, interrupting the power to the inlet valve and starting the outlet pump.</p> <p>OVERFILL SWITCH (see page 11) A float in the base pan influences a microswitch that disconnects the inlet valve and starts the outlet pump.</p> <p>COMBI-DISPENSER (see page 13) The combi-dispenser dispenses both detergent and rinse aid. The dispenser has an adjustable volume chamber for setting the desired amount of rinse aid.</p> <p>TURBO FAN (MODEL 1716) (see page 13) Evacuates the moist air from the machine during the drying phase of the program. The fan system consists of a fan motor that runs a two-part impeller. Dry, cool air is pulled in from the door into one of the impeller halves. A wax motor opens a damper and the moist air is pulled into the other part of the impeller. The dry, cool air and warm, moist air mix and condense in the condensation chamber. The condensed moisture then drains through the channel to the lower sump area. Dry air is then vented out through a channel below the outer door.</p>		

INDICATING MARK ON TIMER KNOB (see page 15)

This is a small red decor lens located above the timer knob. It is solely to indicate cycle selection. It does not light up or indicate power. The "Off" position is when the two red marks are aligned.

ELECTRICAL SUPPLY

The machines are wired for connection to a single-phase, 120V, 15A supply, with a heater power of 1400W, giving a total power requirement of 1600W.

VALUES FOR WIRING DIAGRAMS

Resistance values at 68° F (+/-5°F), 20° C (+/-3°C)
(Values within +/- 10% is normal.)

AP	Drain pump	120V, 60 Hz, 25.5 ohm
CP	Main pump	120 V, 60 Hz, Main = 10.5 ohm, Aux = 14.5 ohm
KD	Combi-dispenser	120 V, 0.31 ohm
EL	Heating element	120 V, 1400 W, 10 ohm
IV	Inlet valve	120 V, 9.93 K ohm
FL	Fan	120 V, 0.25 K ohm
LB	Door switch	
LU	Door	
N	Level switch	
P	Timer	
T	Thermostat	
WAX	Wax motor	1.5–3.0 K ohm
OB	Overflow switch	

The lists below define the meanings of the dashed numbers or letters following a part number:

COLORS:

- 0 White
- 29 Black, bright
- 33 Black
- 36 Dark grey
- 49 Helios grey
- 69 black, metallic
- 77 grey
- 81 metallic
- 95 Stainless Steel

Note: Not all colors are available for all parts.

DOORS:

- M for units with fan
- P for integrated units
- R for decor frames, long door
- S for decor frames, short door
- T for decor frames with adjustable lower part

Date 2000-06		Page 7
------------------------	--	------------------

This page intentionally blank.



Date 2000-06	CASING AND RELATED PARTS	Page 8
-----------------	---------------------------------	-----------

--	--	--

Date		CASING AND RELATED PARTS		Page
2000-06				9
Fig.	Qty	Part No.	Description	Notes
1	1	80 583 53	Sound insulation	
2	1	80 600 41	Sound insulation profile	
3	1	80 575 26	Guard plate	
	4	89 003 52	Screw	RTS ST 4.2x13
4	1	80 707 43	Felt, kick plate	
5	1	80 597 58-	Kick plate	-0, -29, -81
	2	89 009 44-	Screw, kick plate	-0, -29
6	1	80 706 15	Sealing strip	
7	1	80 571 00-	Lower cover	-S-0, -S-29, -95
	2	89 003 52	Screw	RTS ST 4.2x13
	4	80 097 69	Plug for decorframe	White
	4	80 097 69-	Plug for decorframe	-33
8	1	80 706 12	Sound insulation	
9	1	80 584 86	Drip protection for guard plate	
10	2	80 575 49	Bracket, kick plate	
11	2	80 575 50	Spring, kick plate	
	2	89 003 27	Screw	RTS ST 4.2x13 FZB T20



Date 2000-06	CONTAINER AND RELATED PARTS	Page 10
-----------------	------------------------------------	------------

Date		CONTAINER AND RELATED PARTS		Page
2000-06				11
Fig.	Qty	Part No.	Description	Notes
2	1	80 706 13	Sealing strip, casing top	
3	1	80 574 89	Tub seal	
4	1	88 010 98	Lock catch compl.	
5	2	80 579 78-	Ball catch	-77
6	2	80 586 38-	Ball holder,guide rail	-77
7	8	80 579 77	Ball bearings	
8	2	80 579 79-	Basket stop	-77
9	2	80 570 52	Guide rail	
10	4	89 011 10	Screw + o-ring	A2-M6x12 T30 D
11	1	80 570 77	Heating element	1400 W 120 V
	1	80 602 58	Cable holder	For heating
	2	80 023 70	Protection collar, heating	
12	1	80 584 95	Cable holder, door	
13	1	80 701 42	Cable holder	
14	1	80 597 74	Thermostat, 126°-140°F (60°-52°C)	Model 1706
	1	80 583 73	Thermostat, 147°-127°F (64°-53°C)	Double, Model 1716
15	1	80 025 79	Thermostat, 190°F (88°C)	Overheat protection
16	1	80 598 96	Thermostat, 86°-158°F (30°-70°C)	Double
17	1	80 597 61-	Strip side, left	-0, -29, -95
	1	80 597 62-	Strip side, right	-0, -29, -95
	4	89 006 46	Screw	A4 RTS 4.2x13 T20
	2	89 003 52	Screw	RTS ST 4.2x13
18	2	80 706 14	Sealing strip	
19	1	80 575 23	Bottom outer (base pan)	
	2	89 011 04	Screw, casing - bottom	A2-MRT-TT 4x8 T20 FZB
20	2	80 584 91-	Door springs	-77
21	1	80 069 48	Grommet for elec. connection	
22	1	80 502 51	Terminal block	
	1	89 003 57	Screw, terminal block	RTS ST 4.2x25 FZB T20
	1	89 021 31	Screw, grounding terminal bl.	MRT-TT 4x6 FZB T20
	1	89 014 13	Washer	AZ 4.3 FZB
23	1	80 599 91	Cable holder	
24	1	80 602 55	Mount, electrical connection	
25	1	80 704 95	Mount, inlet valve	
	2	89 003 27	Screw	RTS ST 4.2 x 13 FZB T20
26	4	80 721 19	Reinforcement washer	
27	4	80 570 62	Leveling leg	M10x100, 8.8 FZB
28	4	89 011 56	Nut	M6M10 BH8 FZB
29	2	80 519 57	Slide foot, rear only	

Date 2000-06	DOOR	Page 12
-----------------	-------------	------------

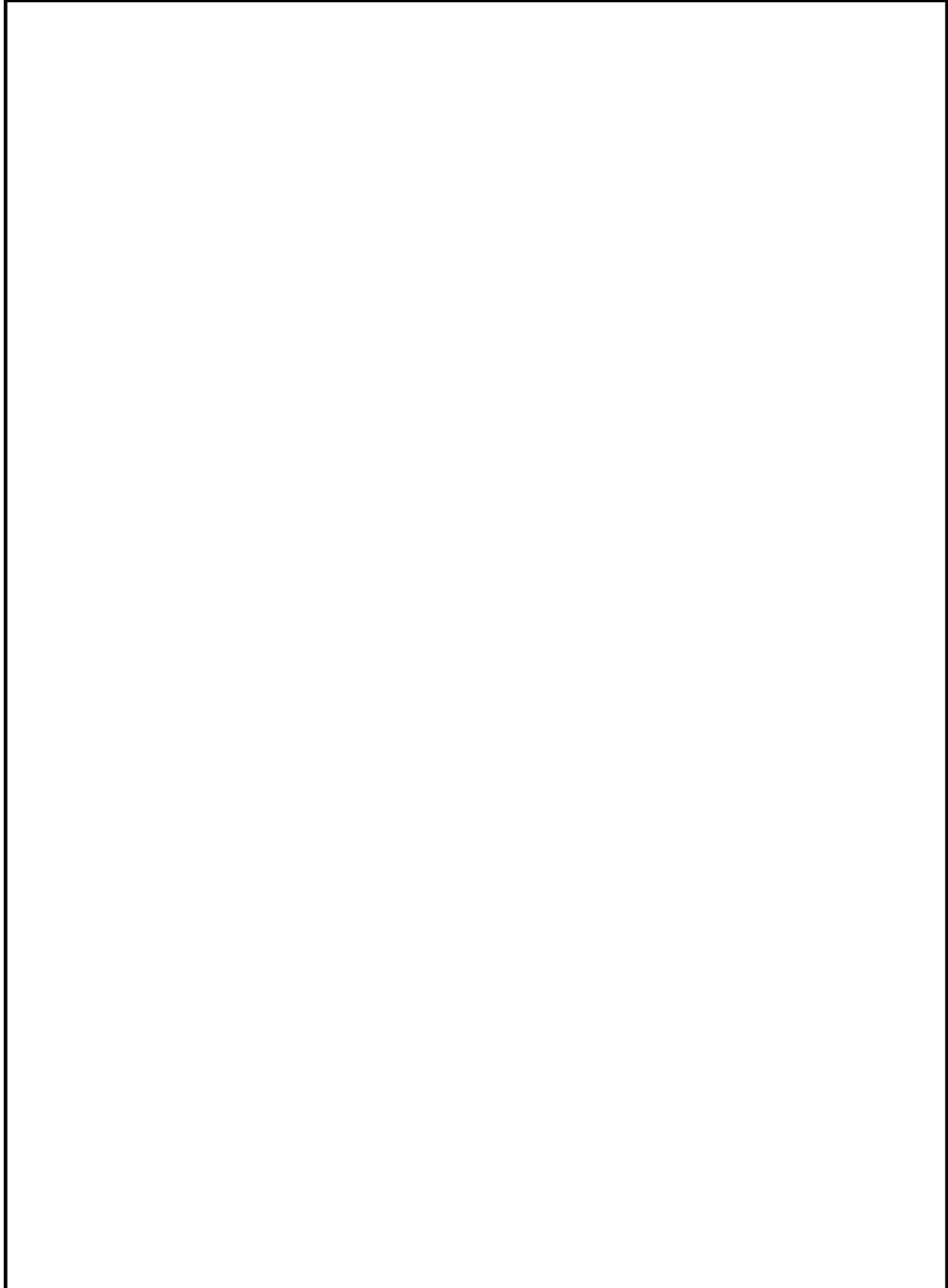

Date				Page
2000-06		DOOR		13
Fig.	Qty	Part No.	Description	Notes
1	1	80 548 98	Wax motor	
2	1	80 585 01	O-ring	84.5x3
3	1	80 600 21	Fan, compl.	
4	1	80 579 63-	Air channel, turbo dry	-S, Model 1716
5	1	80 727 29-	Nozzle, air channel	-0, -33
6	1	88 011 18	Inner door compl., with fan	Model 1716
	1	88 011 17	Inner door compl., w/out fan	Model 1706
	4	89 021 20	Screw	A2-MKFT 5x10-TT FZB
7	1	80 579 64	Lock ring, fan casing	
8	1	80 584 84	Cover plate, fan	
	2	89 020 85	Screw, fan cover plate	A2-PTK 40x10 WN1452 TT
9	1	8070680-	Combi-dispenser	-77
	6	89 020 87	Screw	PTK 40x14 WN1452 FZB
	1	80 719 17	Rinse aid cap	
	1	80 719 18	Combi-dispenser lid	Incl. seal and spring
10	1	80 575 25	Hinge, left	
	1	80 575 24	Hinge, right	
	2	80 575 30	Hinge screw	
	2	33500262	Nut, hinge bearing, locking	4 BH8 FZB
11	2	80 579 48	Slide washer, hinge bearing	
12	1	80 715 87	Holder, cable harness	
	1	89 021 31	Screw, cable harness holder	MRT-TT 4x6 FZB T20
13	1	80 602 54	Door seal lower	L=555 mm
14	1	80 579 85	Brace stand	
	2	89 006 46	Screw, lower stay	A4 RTS 4.2x13 T20
15	1	80 579 86-	Door outer part	-S-0, -S-29, -95
	6	89 006 46	Screw	A4 RTS 4.2x13 T20
	2	89 003 27	Screw	RTS ST 4.2x13 FZB T20
	2	80 561 17-	Screw	-29
	6	80 097 69	Plug for decor frame	White
	6	80 097 69-	Plug for decor frame	-33

Date 2000-06	CONTROL PANEL	Page 14
-----------------	----------------------	------------

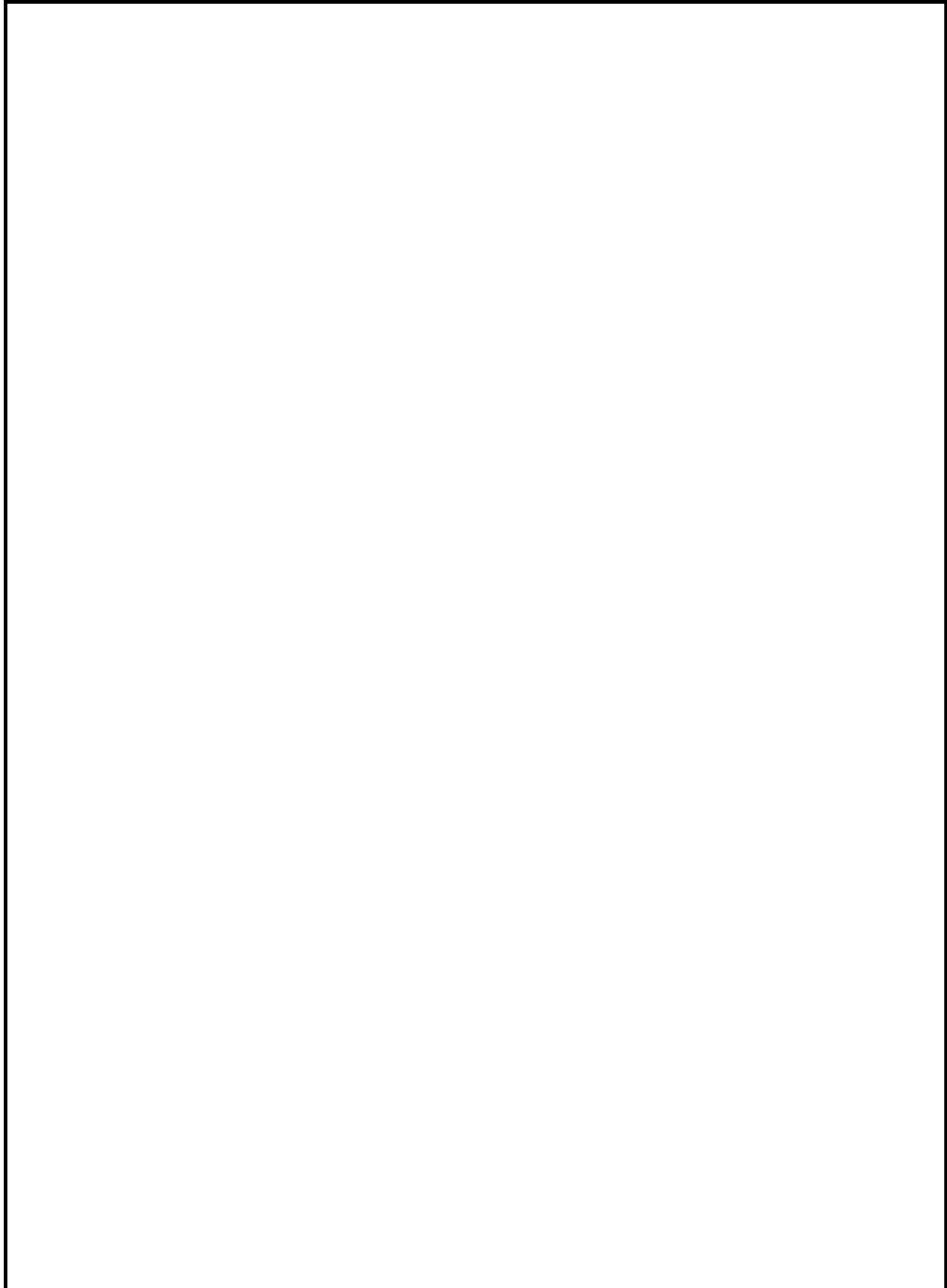

Date		CONTROL PANEL		Page
2000-06				15
Fig.	Qty	Part No.	Description	Notes
1	1	80 575 41-	Handle	-0, -33 (and -81 for Model 1716)
2	1	80 575 45	Safety catch	
3	1	80 575 46	Spring, safety catch	
4	1	80 575 44	Control arm,safety catch	
5	1	80 575 39	Holder, handle assembly	
	2	89 020 85	Screw	A2-PTK 40x10 WN1452
	2	89 020 87	Screw	PTK 40x14 WN1452 FZB
6	1	80 710 98	Cover, microswitch	
7	1	80 554 73	Microswitch	
8	1	80 575 42	Control pin, microswitch	
9	1	80 070 78	Spring, handle	
10	1	80 575 37-	Front panel	-0, -69 (and -81 for Model 1716)
11	1	80 575 38-	Backing for decor plate	-0, -69 (and -81 for Model 1716)
	1	89 020 92	Screw	PTK 40x25 WN1452 FZB
12	1	80 734 04-	Decor insert, Model 1706	-0, -33
	1	80 734 05-	Decor insert, Model 1716	-0, -33, -81
13	1	80 575 40	Bracket, timer	
14	1	80 600 17	Timer	
	2	89 009 44	Screw, timer	MRT-kombi 4x6 FZB T20
15	2	80 579 41	Pushbutton switch	
16	1	80 734 22	Cable harness complete	Model 1706
	1	80 734 36	Cable harness complete	Model 1716
17	2	80 579 82-	Pushbuttons	-0, -33 (and -81 for Model 1716)
18	1	80 565 21	Clip	
19	1	88 011 98-	Knob	-0, -33 (and -81 for Model 1716)
20	1	80 579 59	Decor lens, knob	
	1	80 730 96	Use and Care Guide	

Date 2000-06	DISHWASHING SYSTEM	Page 16
-----------------	---------------------------	-------------------

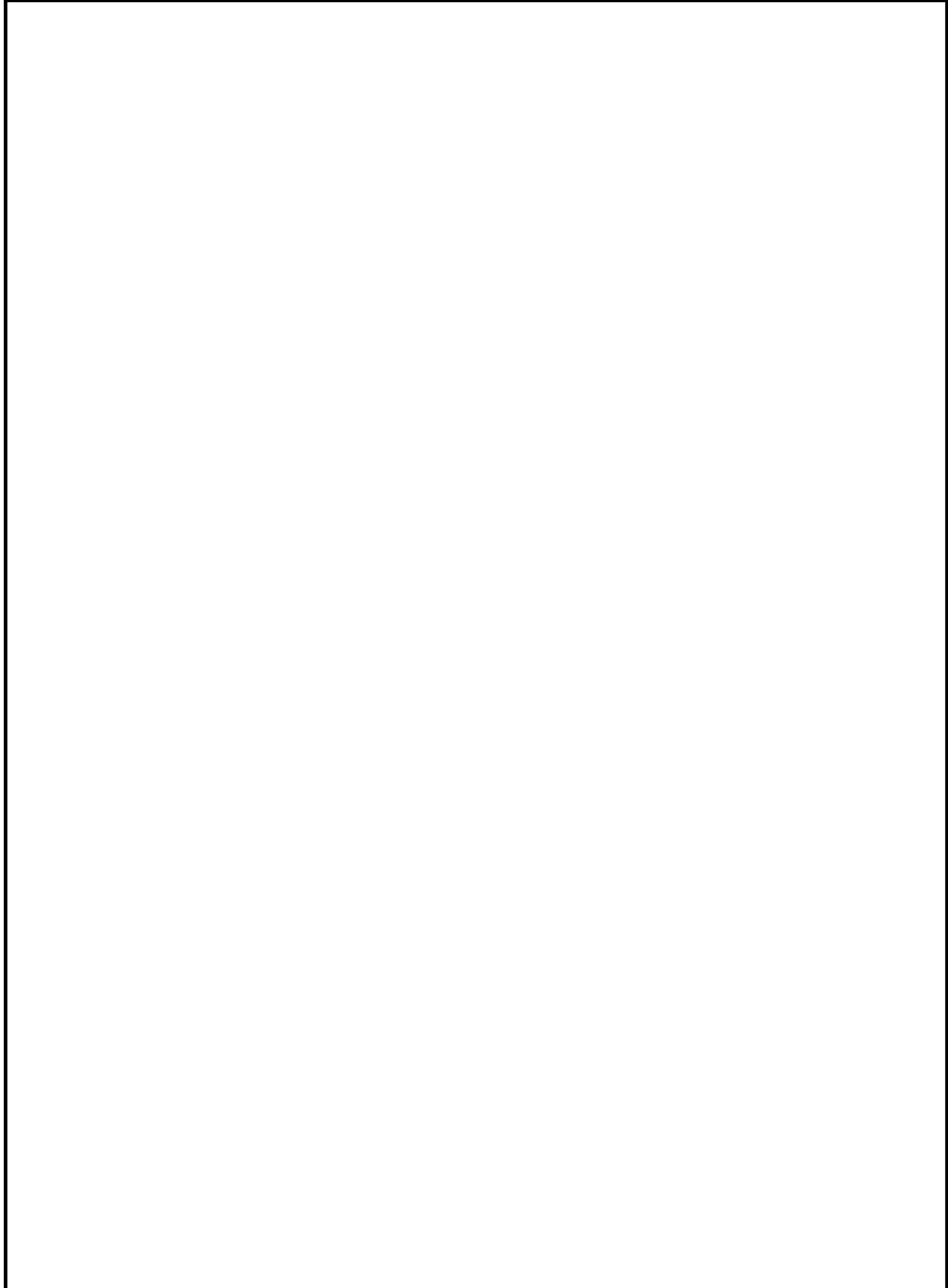

Date		DISHWASHING SYSTEM		Page
2000-06				17
Fig.	Qty	Part No.	Description	Notes
1	1	80 713 37-	Cup shelf, wine glasses	-36, Model 1716
2	1	80 011 99-	Upper basket, w/wheels *	-36 with cup shelf
3	1	80 713 36-	Cup shelf	-36
4	1	80 575 36-	Lock ring, air break	-77
5	1	80 585 04	O-ring, inlet air break	
6	1	80 575 14	Air break	
7	1	80 597 40	Strainer, upper part	
8	4	80 584 98-	Basket wheel, upper	-77
9	1	80 575 06-	Knife stop, upper basket	-77, Model 1716
	2	80 712 14-	Knifestand, upper basket	-77, Model 1716
10	1	88 010 89-	Cutlery basket	-77
11	1	88 012 00-	Lower basket	-36, Model 1716
	1	80 700 43-	Lower basket	-36, Model 1706
12	8	80 095 16-	Basket wheel, lower	-77
13	1	80 584 93-	Lower basket insert	-36, Model 1716
14	1	80 703 04	Outlet hose	
15	1	80 726 95	Spray arm, upper	
16	2	89 012 62	Nut, spray arm bearing	
17	2	80 520 95	Washer, spray arm bearing	
18	2	80 570 70-	Spray arm bearing	-77
19	1	80 570 68-	Spray pipe bearing, upper	-77
20	1	80 570 63	Spray pipe	
21	2	80 521 89	Hose clip, inlet valve	17.0-706
22	1	80 585 02	Rubber hose, inlet valve	
23	1	80 721 21	Inlet valve	
	2	89 020 87	Screw	PTK 40x14 WN1452 FZB
24	1	80 726 92	Spray arm lower	
25	1	80 570 67-	Spray pipe bearing, lower	-77
26	1	89 017 55	O-ring, lower spray pipe bearing	
27	1	80 570 69	Nut, spray pipe bearing	
28	2	80 574 84	Hose, circulation pump	
29	4	80 520 97	Hose clip, circ. pump hose	44.0-708
30	1	80 550 95	Rubber buffer, circ. pump	
31	1	80 710 24	Level switch (pressure)	
32	1	80 570 53	Float, base pan	
33	1	80 600 68	Microswitch float	
34	1	80 585 00	Rubber hose	5x8x340
35	1	88 011 23-	Bottom well, sump	-77
36	1	80 585 03	O-ring, bottom well, sump	109.5x3
37	1	80 574 87-	Cover plate	-33
38	1	80 025 84	O-ring, outlet pump	49.5x3
39	1	80 720 32	Outlet pump	
40	1	80 522 39	Hose clip	31.6-708
41	1	80 574 88	Lock ring, bottom well, sump	
42	1	80 584 54	Cover plate	
43	1	80 579 72-	Filter basket, coarse	-77
44	1	80 574 86-	Insert, filter basket	-77
45	1	80 712 50	Circulation pump	

*When ordering an upper basket, you also need to order the knife stop and knife stand (see Figure 9).

PROGRAMVERK MED AVSPOLNINGSPROGR. OCH FLAKTTORKNING TIMER WITH RINSE AND HOLD PROGR. AND FAN DRYING TIMER MIT ABSPOLNUNGSPROGRAMM UND GEBLÄSE TROCKNUNG

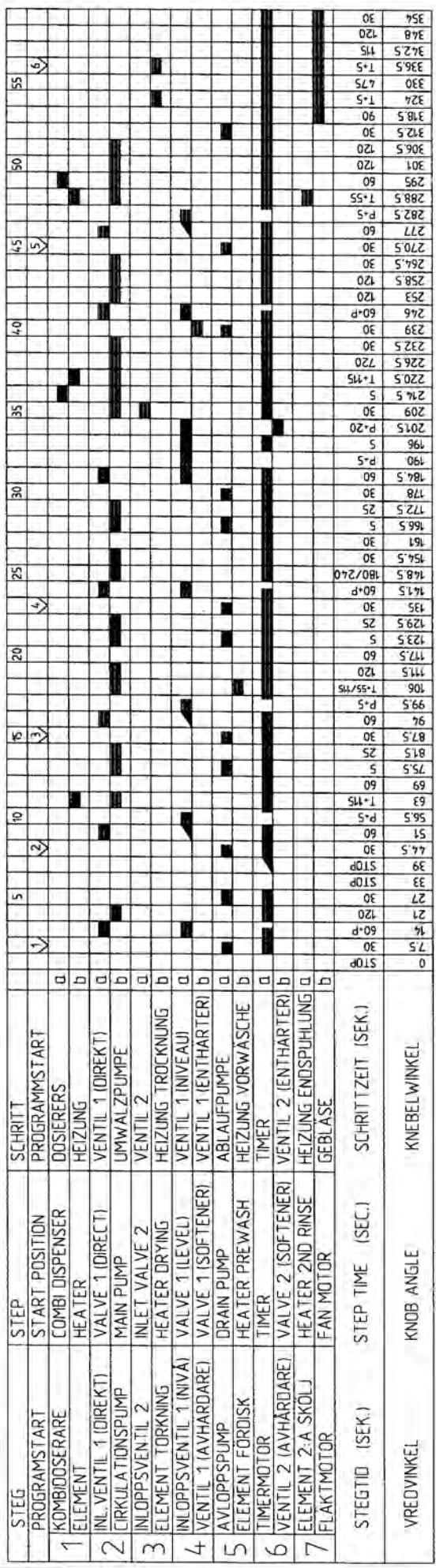

Article No	Name of item	Qty	Material,dimensions,type,etc.
Scale:	Gen tolerance:		TIMER DIAGRAM DW950/1/2/C
Designed by	Drawn by		TIMER DIAGRAM DW950/1/2/C
Iss by	Year	Week	
80 584 79	00	94	43
Replaced by	Replaced by		
01	01		

01	Contact P7a impl.	ML 98 32
Rev.ind	Revision	Appd Year Week

Date
2000-06**SERVICE INFORMATION**Page
18

Product: DW95

Date: 98-03-12

TOPIC: DOOR SPRINGS

There are three different sets of door springs, as defined below:

Part Number	Machine	Weight Capacity	Color Coding
80 584 91-77	For all standard machines	9 lbs.	none
80 602 32-77	For integrated and fully-integrated machines	12 lbs.	yellow
80 713 23-77	Heavy-duty for wooden panels, available as accessory part	22 lbs.	red



Color code

Product: DW95

Date: 98-03-13

TOPIC: WATER LEVEL

Switch level transferred to measuring points on the coil arm bearing.

Timer-controlled machines

Water flow inlet valve = 3.8 +/- 5% ltr / min

Intake time = 60 seconds

- Max. tol. 3.8 +5% = 3.9 ltr +3 mm
- Max. tol. 3.8 +/- 5% = 3.9 ltr +2 mm
- Max. tol. 3.8 -5% = 3.9 ltr +1 mm

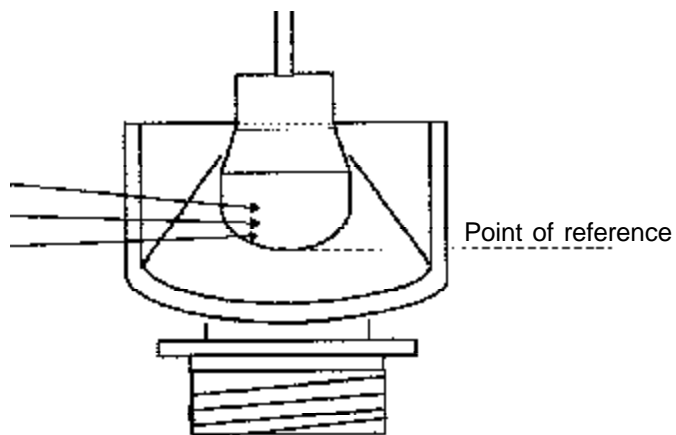

Electronic machines

Water flow inlet valve = 3.8 +/- 5% ltr / min

Intake time = 57 seconds

- Max. tol. 3.8 +5% = 3.7 ltr +1 mm
- Max. tol. 3.8 +/- 5% = 3.51 ltr +0 mm
- Max. tol. 3.8 -5% = 3.3 ltr -1 mm

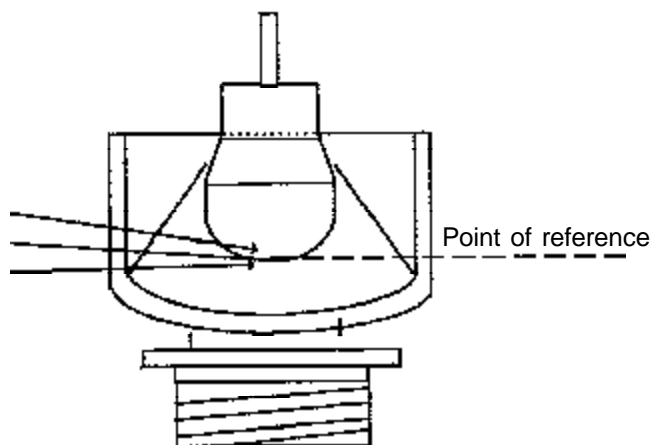

Note: Start with dry bottom well, which gives a 2mm lower level.

Date
2000-06**SERVICE INFORMATION**Page
20

Product: DW95

Date: 98-03-13

TOPIC: GUIDE PIN FOR DOOR LOCK

Occasionally, the guide pin for the door lock may freeze or become stuck, causing the machine not to stop when the door is opened. To prevent this, you can lubricate the guide pin with petroleum jelly.

