

WTA 35 & WTL 54 Dryer Training Program



Vented model - WTA3510UC



Condensation model - WTL5410UC

WTA 35 & WTL 54 Training Program

- Features and Benefits
- Product Description
- Warranty
- Installation
- Operation
- Disassembly
- Reassembly
- Wiring Diagram
- Service Tips



Features and Benefits

- Anti-crease feature
- Smooth stainless steel drum - won't rust & is gentle to clothes
- Auto-dry with 2 digital moisture sensors and 3 temperature sensors
- Moisture and temperature sensors automatically determine when laundry is dry, preventing over-drying and damaging clothing.
- Regular/Cotton - 6 settings
- Permanent Press - 5 settings
- Reverse tumble action
- Spanish and French fascia inserts (WTA 3510/WTL 5410)
- UL listed (U.S. & Canada)



Product Description

- Electronic *Duotronic* controls
- *Regular/Cotton, Permanent Press, Delicates & Air fluff* settings
- Stainless steel drum
- *Anti-Crease* feature
- Extra-fine lint screen
- Digital and LED displays
- Adjustable end of cycle signal
- Terminal box with 30A cord and outlet for 15A washer cord
- Interior drum light
- Vented (WTA 35) and condensation (WTL 54) versions
- UL listed (U.S. & Canada)

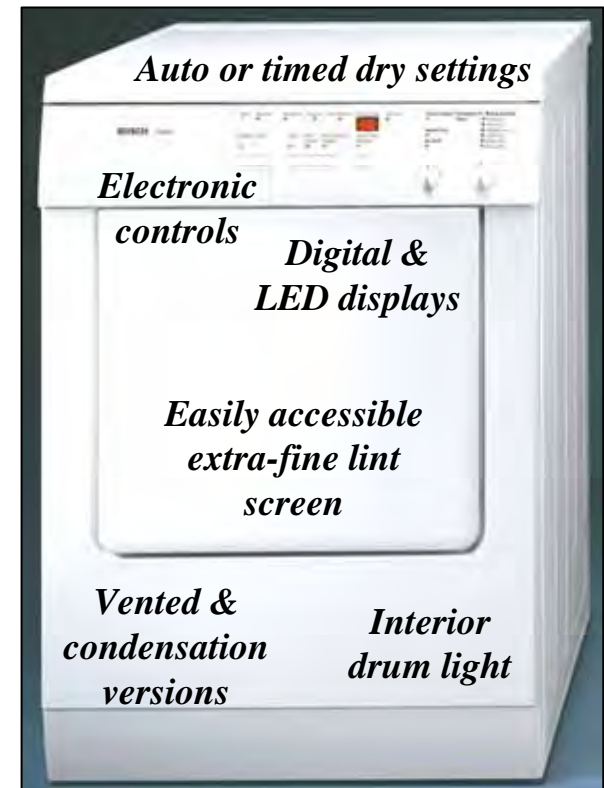

Warranty (1)



Bosch Dryers and Dryers Limited Lifetime Warranty

Statement of Limited Warranty

The warranties provided by BSH Home Appliances ("Bosch") in this Statement of Warranties apply only to Bosch clothes dryers and dryers sold to the first using purchaser by Bosch or its authorized dealers, retailers or service centers in the United States or Canada. The Warranties provided herein are not transferable, and take place from date of installation.

1 Year Full Limited Warranty

Bosch will repair or replace, free of charge, any component part that proves defective under conditions of normal home use, labor and shipping costs included. Warranty repair service must be performed by an authorized Bosch Service Center.

2 Year Limited Warranty

Bosch will provide replacement parts, free of charge, for any component part that proves defective under conditions of normal home use, shipping costs included.

Warranty (2)

5 Year Limited Warranty On Electronics

Bosch will repair or replace, free of charge, any microprocessor or printed circuit board that proves defective under conditions of normal home use for a period of five years from the date of original installation, labor charges excluded.

5 Year Limited Warranty On Motor

Bosch will repair or replace, free of charge, any pump or component part of the pump that proves defective under conditions of normal home use for a period of five years from the date of original installation, labor charges excluded.

5 Year Limited Warranty On Cabinet Rust-Through

Bosch will replace any cabinet part, free of charge, if that cabinet part should rust through under conditions of normal home use, labor charges excluded.

Lifetime Limited Warranty Against Stainless Steel Rust-Through

Bosch will replace your clothes dryer or dryer, free of charge, with the same model or a current model that is equivalent or better in functionality if the drum should rust through under conditions of normal home use, labor charges excluded.

For location of nearest repair depot call 1-800-944-2904 from 5:00 AM - 5:00 PM M-F (Pacific time)



Warranty -- Serial # Label

The serial # label, located on the rear of the dryer (on the right side), shows necessary warranty information.

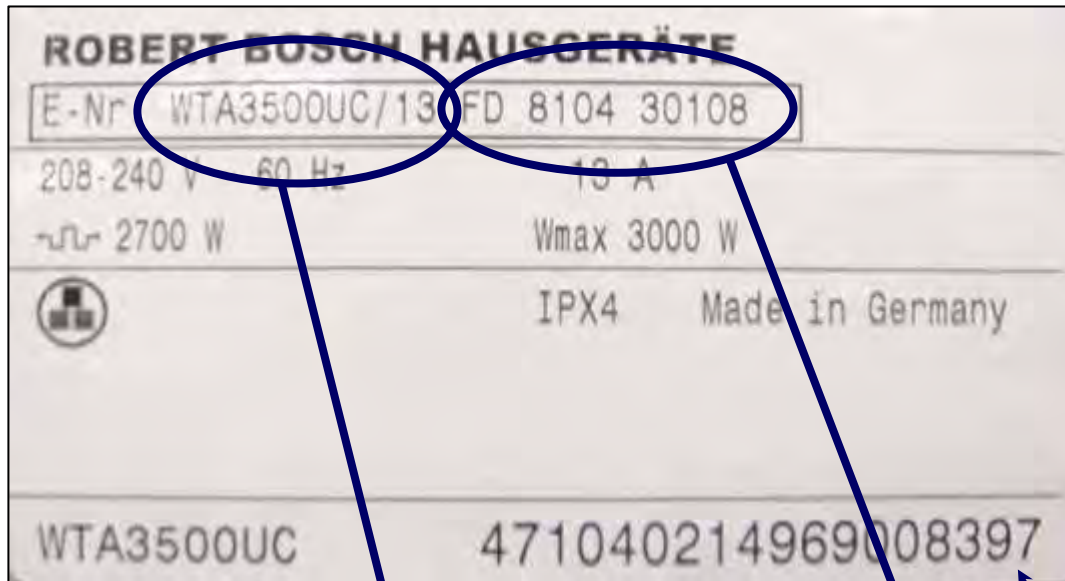
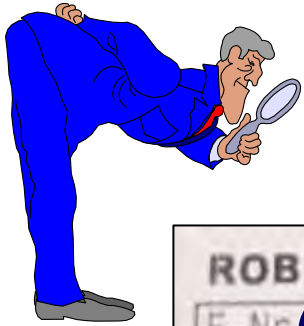

Serial #
label



NOTE: There is another label on the inside of the door, but it doesn't show the serial #.

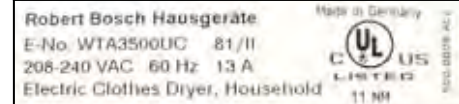

- **Model #** - “WTA3500UC/13”.

- **Serial #** - “FD 8104”. To find when the product type was built, add 20 to the 1st two digits to get the year (81 + 20 = 101 → product type was built in 2001). The last two digits show the month (04 = April).

Factory serial # - Can convert factory serial # to FD # for warranty use. 1st 2 digits show factory # (47 = Nauen), 3rd digit shows year (1 = 2001), 4th & 5th digits show month built (04 = April). So, serial # starting with “47104...0008397” = dryer built @ Nauen with FD 8104 30108.

Installation -- Reprint of Installation Instructions (1)

Installation Instruction

Introduction

Read these installation instructions completely and carefully. They will save you time and effort and help to ensure optimum dryer performance. Be sure to observe all listed warnings and cautions.

These installation instructions are intended for use by qualified installers. In addition to these instructions the dryer must be installed:

- In the United States, in accordance with the National Electric Code, ANSI/NFPA70 – latest edition/State and Municipal codes and/or local codes.
- In Canada, in accordance with the Canadian Electric Code C22.1 – latest edition/Provincial and Municipal codes and/or local codes.

Tools Needed for Installation

The following tools are needed for installation of this dryer:

- Box cutter
- Flat blade screwdriver
- #2 Phillips head screwdriver
- Duct tape
- Caulking gun and compound
- Level
- Safety goggles
- Gloves

Parts Supplied for Installation

- Condensation water drain hose (WTL 5410 only)
- Stacking kit

Parts Needed for Installation (Model WTA 3510 only!)

Four inch (approx. 100 mm) diameter metal exhaust duct (rigid or flexible) of proper length and with elbows and exhaust vent hood required to vent to outdoors.

Dryer Electrical Cord

The Bosch dryer comes with a 4-wire power supply cord pre-installed. This cord fits a 4-wire receptacle as shown in the upper section of Figure 11.

If your receptacle is a 3-wire receptacle, as shown in the lower section of Figure 11, a 3-wire "Dryer Cord" must be purchased locally. The 4-wire cord must then be removed and the 3-wire cord installed in its place, as instructed in following section.

When purchasing a 3-wire power supply cord make sure the cord meets following requirements:

- U.L listed in the USA, CSA listed in Canada
- 240 volt rated (minimum)
- 30 ampere
- Type SRD or SRDT
- Five feet long (minimum)

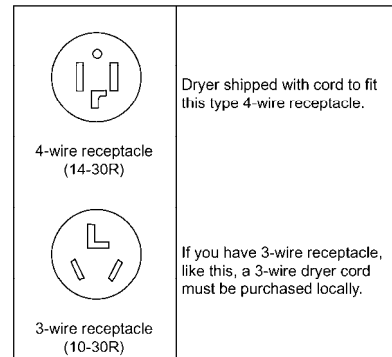
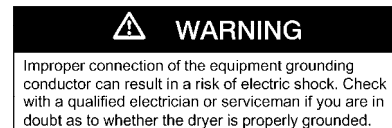

Figure 11.

Grounding Instructions

This appliance must be grounded. In the event of malfunction or breakdown, grounding will reduce the risk of electric shock by providing a path of least resistance for the electric current. This appliance is equipped with a cord having an equipment grounding conductor and a grounding plug. The plug must be plugged into an appropriate outlet that is properly installed and grounded in accordance with all local codes and ordinances.



NOTE: Be sure to follow all national & local codes.

Additional Grounding Procedure

Some local codes may require a separate ground. In such cases, the required accessory ground wire, clamp and screw must be purchased separately.

Never ground the dryer to plastic plumbing lines, gas lines or water pipes.

Electrical Receptacle

The receptacle for the dryer cord must be located so that the power supply cord will be accessible when the dryer is in the installed position.

Venting

The WTA 3510, electric vented dryer, is intended to be vented to the outdoors. To prevent build-up of moisture and accumulation of lint indoors, as well as to maintain maximum drying efficiency, it is recommended that the Bosch WTA 3510 be vented to the outdoors.

Ductwork

Four-inch (approx. 100 mm) diameter ducting should be used. Use either rigid metal or flexible metal ducting material. **DO NOT** use non-metal duct with this dryer.

Exhaust ducts should be as straight as possible. Exhaust ducting longer than recommended can extend drying time, can collect lint and may effect dryer performance. Joints should be secured with duct tape. **DO NOT** use screws to secure joints as lint can collect on the screws. See **Step 4, Exhaust Duct**, in following section titled **INSTALLATION** for recommended routing and duct length calculations.

NOTE: Use 4" metal duct (flexible or rigid) with these dryers. Do not use non-metal duct.

NOTE: Dryers must be grounded to reduce the risk of shock should any malfunctions occur.

Exhaust Vent Hood

The exhaust duct must end with an approved exhaust vent hood with swing out damper(s). **DO NOT** use an exhaust vent hood with magnetic latches. To avoid restriction of exhaust the outlet must be a minimum of 12 inches (30 cm) above ground level, or any other obstructing surface. See Figure 17.

Condensate Drain

The WTL 5410, electric condensation dryer, dries by condensing the moisture from the dryer air and then pumping this condensate out of the dryer.

The WTL 5410 must have its condensate hose connected to a suitable drain. See **Step 5, Condensate Hose Connection**, in the following section titled **INSTALLATION**.

Stacking Kit

A stacking kit is supplied with each dryer in order to stack Bosch dryer upon a Bosch washing machine. This part is only necessary if stacking the units is desired.

Stacking Kit with Pull-out-tray – WTZ 1180

As an additional accessory for purchase, Bosch offers a stacking kit for a Bosch washer and dryer that incorporates a pull-out-tray. The tray offers an area for folding and easier unloading of the dryer. See your local dealer for availability and price.

Installation -- Reprint of Installation Instructions (2)

Technical Data

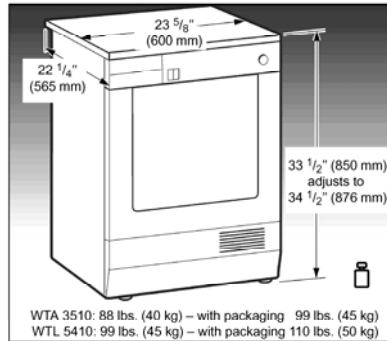

Figure 12.

Electrical Requirements

The Bosch dryers should be CONNECTED TO AN 30A INDIVIDUAL BRANCH CIRCUIT. North American models have the following electrical rating:

Model	Volts	Hertz	Amperes	Watts (max.)
WTA 3510	208/240	60	13	3,100
WTL 5410	208/240	60	13	3,100

Check the rating plate on the dryer to make sure your machine has this rating.

Choosing the Location

The dryer should not be installed:

- in an area exposed to dripping water or outside weather conditions
- in an area where it (and in the case of the WTA 3510, its exhaust duct) will come in contact with combustible materials, such as curtains, drapes or paper.
- in areas where water may freeze
- in an area where gasoline or other flammables are kept or stored.

Check local codes before choosing a location. Some codes do not permit installation of a clothes dryer in a garage, closet, mobile home or sleeping area. Your local building inspector should be able to advise you of the codes in your area.

Minimum Installation Clearances

	Alcove or Under Counter	Closet
Sides	0" (0 mm)	0" (0 mm)
Top	0" (0 mm)	10" (250 mm)
Rear	1" (25 mm)	5" (125 mm)

Ventilation Requirements

	Alcove or Under Counter	Closet
WTA 3510	Ensure air flow of 112 cu.ft./min (3,2 cu.m./min) through dryer	Closet door must have 2 (louvered) openings, each having a minimum area of 60 sq. inches (387 sq. cm.), located 3 inches (8 cm) from bottom and top of door. *
WTL 5410	Ensure air flow of 118 cu.ft./min (3,3 cu.m./min) through dryer	Closet door must remain open during dryer operation.

* A louvered door with equivalent air opening is acceptable.

Flooring

The dryer should be installed on a level, solidly constructed floor. DO NOT install the dryer on a carpeted floor.

Dryers must be installed on level, solidly constructed floors.

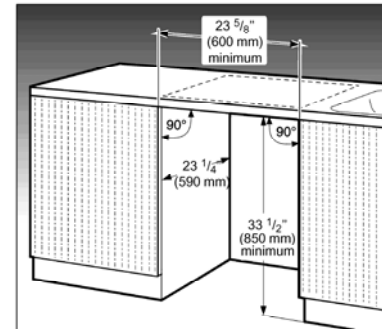

Figure 13.

Built-in Installation

The Bosch dryer can be built-in: that is, you can install the Bosch dryer under-counter in a kitchen cabinet opening. The cabinet opening should be square and have the dimensions as shown in Figure 13.

Note: If installed under a countertop, the countertop must be continuous and securely attached to neighboring cabinets.

WARNING

DO NOT install the dryer in an area where gasoline or other flammable materials are kept or stored.

The dryer must be installed in a room that is adequately ventilated. Make sure there is an adequate supply of fresh air. Both the WTA 3510, electric vented dryer, and the WTL 5410, electric condensation dryer need an adequate supply of fresh air for optimum performance.

CAUTION

DO NOT install the dryer in a closet with a solid door. The dryer must have make up air as specified on page 17 under Ventilation Requirements.

Don't install dryers in closets with solid wooden doors as dryers must have make-up air.

HINT: Washers and dryers are both rated 15A @ 240VAC. Washers have 15A cords and plugs provided. Dryers have 30A cords provided to handle the power requirements when washers are plugged into the dryer terminal boxes.

Installation -- Reprint of Installation Instructions (3)

INSTALLATION

Step 1

Unpack the Dryer

Carefully remove the packing material from the outside of the dryer.

Step 2

Inspect the Dryer

Thoroughly inspect the dryer, prior to installation, for possible freight or cosmetic damage.

Step 3

Position Dryer near Installation Area

Move the dryer so that it is within four feet of the desired position.

Note: Corrugated packing material may be used to protect the floor. Do not use corrugated material with staples.

Step 4

Exhaust Duct

(Model WTA 3510 only!)

The WTA 3510 must be exhausted to the outdoors.

The duct may be connected to the left, right or back of the WTA 3510, electric vented dryer. If connecting to the left or right hand side of the dryer, remove the sealing cover from the side to be used, as shown in Figure 14.

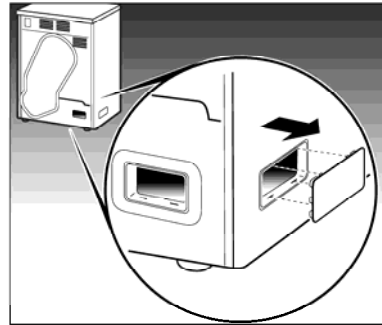

Figure 14.

The sealing cover should then be placed over the open vent opening at the back of the dryer, as shown in Figure 15.

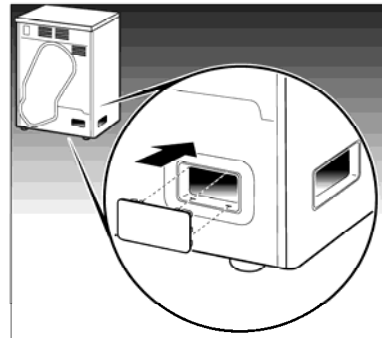

Figure 15.

The connecting piece supplied with your WTA 3510 dryer must then be inserted in the vent opening that will be used. See Figure 16.

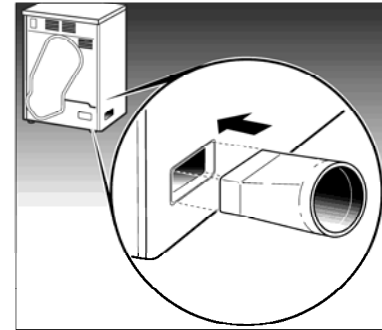

Figure 16.

Checking/Installing Exhaust Ducting

The ducting system of the dryer, for optimum performance, should be as short as possible with a minimum number of elbows. Your WTA 3510 electric vented dryer will work best when the venting system has as few restrictions to the flow of air as possible.

Whether installing to an existing venting system or a new venting system, make sure that all ducting is clean and free of lint and does not exceed the length per elbows as shown in Table 1, below:

Number of Elbows	Maximum length of duct	
	Rigid Duct	Flexible Duct
0	30 ft. (914 cm)	20 ft. (610 cm)
1	22 ft. (670 cm)	15 ft. (457 cm)
2	14 ft. (427 cm)	9 ft. (274 cm)
3	6 ft. (183 cm)	4 ft. (122 cm)

Table 1.

Every elbow must have a minimum diameter of 4 inches (10 cm).

The above table assumes the use of an approved exhaust vent hood with a swing out damper. **DO NOT** use an exhaust vent hood with magnetic latches. To avoid restriction of exhaust the outlet must be a minimum of 12 inches (30 cm) above ground level, or any other obstructing surface, as shown below, in Figure 17.

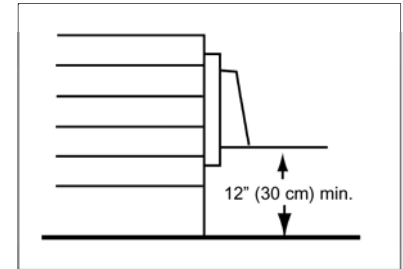

Figure 17.

Step 5

Condensate Hose Connection (Model WTL 5410 only!)

The WTL 5410 must have its condensate drain line installed and run to a suitable drain. The connection for the condensate hose is located on the back of the WTL 5410, see Figure 18.

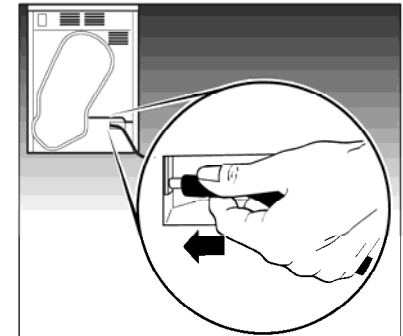

Figure 18.

Connect the condensate drain hose to the dryer. The other end should then be placed and secured at a nearby sink or drain, or if installed with a washer it may, room permitting, be installed next to the washer drain hose and drained to the same drain used by the washer.

Be sure to follow all local codes and regulations in running the condensate to a suitable drain.

WARNING

1. To reduce the risk of fire, this dryer **MUST BE EXHAUSTED OUTDOORS.**
2. **DO NOT** use non-metal duct with this dryer.
3. **DO NOT** use duct smaller than 4 inches in diameter.
4. **DO NOT** use exhaust hoods with magnetic latches.
5. **DO NOT** exhaust the dryer into a chimney, furnace cold air duct, attic, crawl space, or any other ductwork used for venting.
6. **DO NOT** install flexible duct in an enclosed wall, ceiling or floor.
7. **DO NOT** crush or kink the duct.
8. Do clean and inspect the exhaust system on a regular basis; once a year, at a minimum.
9. The exhaust duct must end with swing out damper(s).

Be sure to install the exhaust according to all governing codes and ordinances. Rigid metal duct is recommended for venting this dryer. If flexible metal duct is used, be sure it is fully supported when the dryer is in its final position. Excess ducting should be trimmed off to avoid sagging or kinking of the ductwork.

HINT: Use as few elbows as possible.

HINT: Don't exceed maximum duct lengths shown in Table 1.

Installation -- Reprint of Installation Instructions (4)

Step 6 Electrical

The Bosch dryer comes with 4-wire power supply cord pre-installed. This cord fits a 4-wire receptacle as shown in the upper section of Figure 11.

If your receptacle is a 3-wire receptacle, as shown in the lower section of Figure 1, a 3-wire "Dryer Cord" must be purchased locally. The 4-wire cord must then be removed and the 3-wire cord installed in its place.

Electrical Connection, 4-Wire

For a 4-wire system, all that is necessary is to plug the 4-wire power supply cord into the 4-wire receptacle of the proper rating.

Note: The receptacle should be located so that the plug and receptacle will be accessible when the dryer is in its final installed position.

Electrical Connection, 3-Wire

If your receptacle is a 3-wire receptacle as shown below, Figure 19, you must obtain a 3-wire dryer cord. Dryer cord can usually be found at your local hardware supply, electrical supply or home center. Cord should have closed loop or upturned end wire terminating connectors.

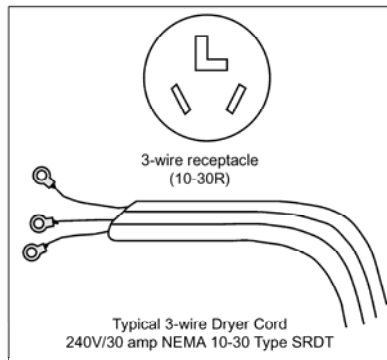

Figure 19.

Note: If the dryer is installed in a mobile home or in areas where local codes do not permit grounding, only a 4-wire power supply cord shall be used.

CAUTION: Dryers must be grounded to reduce the risk of shock.

To Change Cord:

1. Make sure that the dryer is not plugged into any power outlet.

⚠ WARNING

DO NOT plug end of dryer power cord into a live receptacle before connecting dryer power cord to dryer terminals and closing junction/splitter box as described below.

DO NOT reuse old power supply cord.

Power cord must be changed only by a qualified person.

2. Remove the screw from the cover of the junction/splitter box located at the top rear of the dryer.
3. Remove the green ground wire from the ground terminal.
4. Remove the red, white and black wire from the terminal block.
5. Loosen the 2 screws in the U.L. strain relief clamp, holding the 4-wire cable.
6. Thread the 4-wire cable out through the U.L. strain relief clamp and throw away.
7. Thread the new 3-wire dryer cord through the U.L. strain relief clamp.
8. Attach the power cord Ground conductor (the center wire) to the Ground terminal. Tighten the terminal so that it securely holds the Ground conductor.
9. Attach the two remaining power cord outer conductors to the 2 terminals labeled L. Tighten both screws so that the power conductors are securely held in place. See Figure 20.
10. Tighten the screws on the U.L. strain relief so that the power cord cannot be moved.

4-wire connection

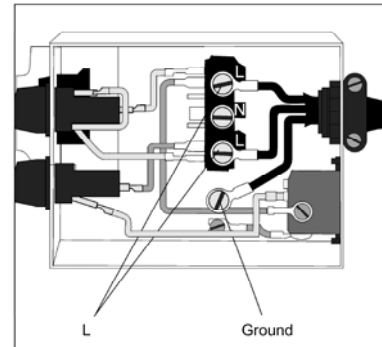
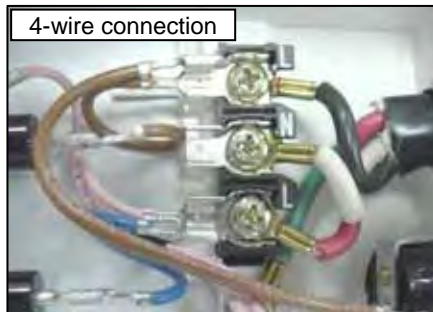

Figure 20.

11. Check the nut on the U.L. strain relief clamp to make sure that it is tight and the strain relief clamp cannot turn.
12. Replace the cover on the junction/splitter box and fasten in place.

The dryer is now ready to be plugged into the 3-wire receptacle, of the proper rating.

Note: The receptacle should be located so that the plug and receptacle will be accessible with the dryer in its installed position.

HINT: The dryer uses a **NEMA 10-30P** 240V, 30A, 4-wire plug, which mates to a NEMA 10-30R outlet (receptacle).



Additional Grounding Procedure

Some local codes may require a separate ground. In such cases, the required accessory ground wire, clamp and screw must be purchased separately. **Never ground the dryer to plastic plumbing lines, gas lines or hot water pipes.**

Step 7

Position and Level the Dryer

Place the dryer in position on a clean, level, solidly constructed floor. Installation on any type of carpeting is not recommended.

With dryer in position, it must then be leveled. Check dryer, using level as shown in Figure 21.

CAUTION

Do not slide dryer across the floor if leveling legs have been extended. Legs and/or dryer base may be damaged if dryer is slid across floor with leveling legs extended.

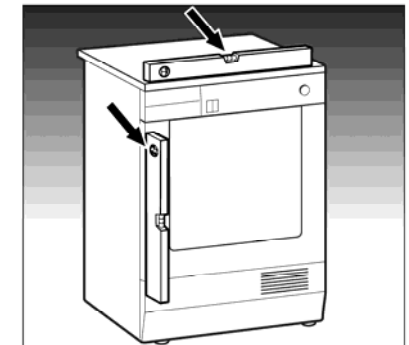

Figure 21.

CAUTION: When moving a dryer, screw in the feet (leveling legs) first so they won't be damaged.

Installation -- Reprint of Installation Instructions (5)

The dryer should be level with all four feet firmly on the ground. The dryer must not wobble.

If the dryer is not level or if it does wobble, the legs must be adjusted. Refer to Figure 22. Adjust the leveling legs until the dryer does not rock and is level, both front-to-back and side-to-side.

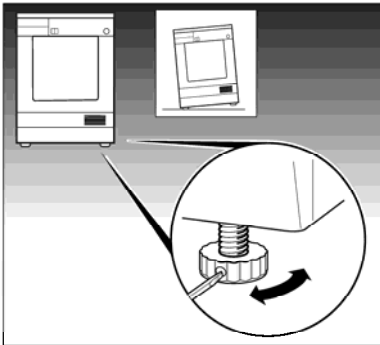

Figure 22.

Step 8

Connect Duct System to Dryer (Model WTA 3510 only!)

Connect the exhaust ducting system to the dryer exhaust outlet.

Step 9

Final Check List

1. Review the electrical requirements (and for WTA model the exhaust requirements) and steps 1 through 8 to make sure they were performed properly.
2. Make sure the electrical supply is on.
3. Read the Use and Care Manual to fully understand how your dryer operates. Turn on the dryer. Select the "Heated Dry" cycle and let the dryer run for 2–5 minutes.
4. After 2–5 minutes stop the dryer and open the door. You should feel heat inside the dryer.
5. If the dryer does not operate, refer to the SELF-HELP and the SERVICE and REPAIR sections of the Use and Care Manual.
6. Upon completing check, turn dryer off.
7. **LEAVE INSTALLATION INSTRUCTIONS AND USE AND CARE MANUAL WITH OWNER.**

CAUTION: When moving a dryer, screw in the feet (leveling legs) first so they won't be damaged.

Operation -- Fascia Panels

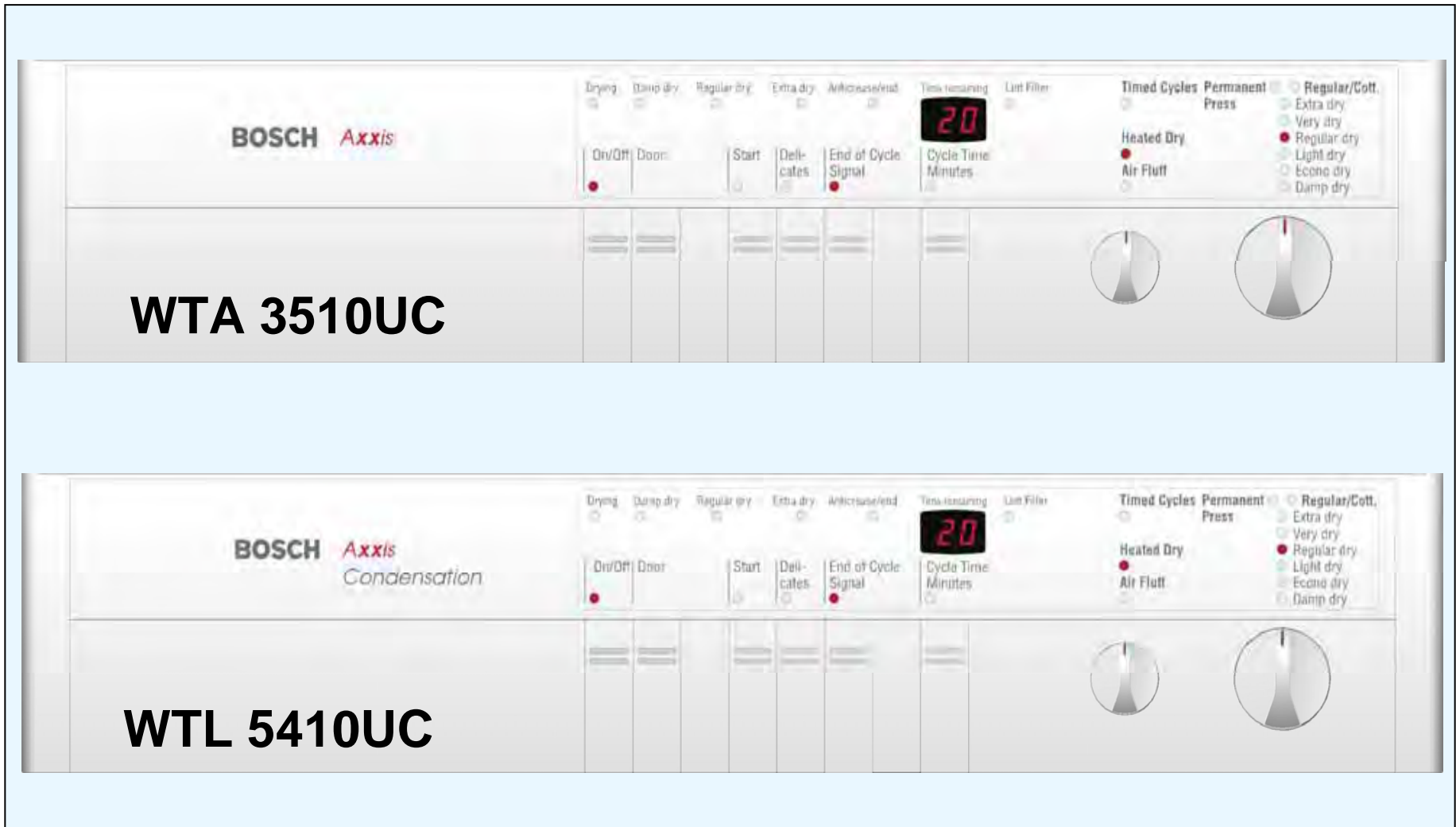

Operation -- Controls

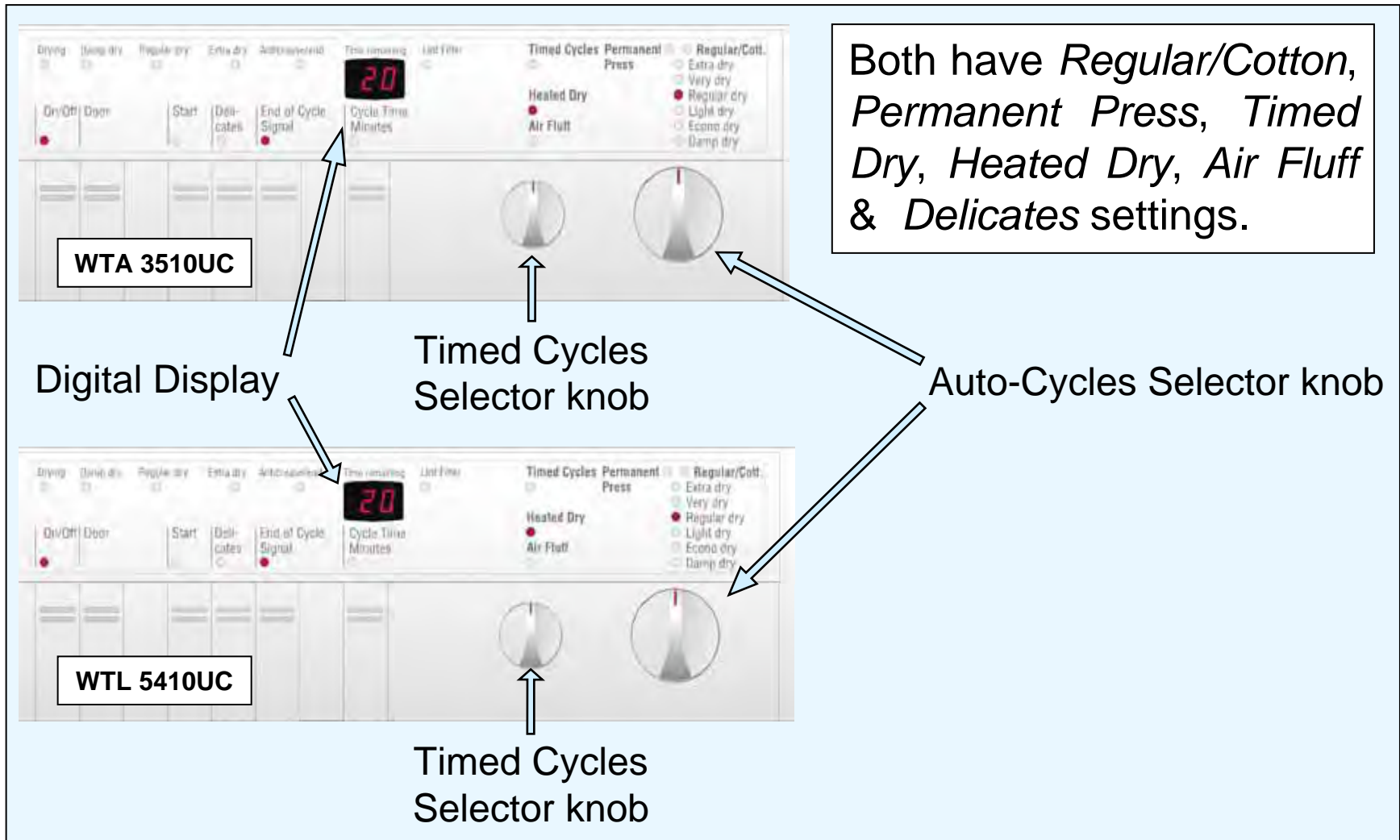

Operation -- Cleaning Lint Filter

Lint Filter

The lint filter should be cleaned after each use or If the **Lint Filter** light becomes illuminated and the buzzer sounds during operation of the dryer:

1. Immediately stop the dryer by depressing the **On/Off** button.
2. Depress the **Door** button and open the door.
3. Remove the filter.
4. Clean the filter.
5. Replace the filter.
6. Let the dryer cool down.
7. Close the door.
8. Press the **Start** button to restart the dryer.



Operation -- Cleaning WTL 54 Heat Exchanger (Condenser)

Heat Exchanger (WTL 54 models only)

The heat exchanger should be cleaned 3–4 times a year; more often if used frequently. To clean the heat exchanger:

1. With the dryer turned off and disconnected from the electrical supply. Disconnect the power cord by grasping the plug, not the cord.
2. Depress the **Door** button and open the door.
3. Press the button for opening the heat exchanger/inlet panel, as shown in Figure 6.
4. Open the panel fully.
5. Turn the retainers on each side of the heat exchanger towards each other, in the direction of the arrows as shown in Figure 7.
6. Remove the heat exchanger by slowly pulling it forward and out of the dryer.
7. Clean the heat exchanger thoroughly with water. Allow the water to run freely through the heat exchanger. See Figure 8.
8. Allow heat exchanger to dry thoroughly before reinserting into the dryer.
9. Once the heat exchanger is completely dry, reinsert it into the dryer. The handle must be underneath the heat exchanger. Turn the retainers back to their original position.
10. Close the heat exchanger/inlet panel by pressing firmly on both the upper left and right hand sides, as shown in Figure 9, until it snaps into place.

Note: The dryer door can only be closed if the heat exchanger/inlet panel is properly closed and locked in place.

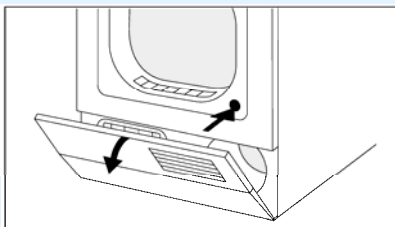

Figure 6.

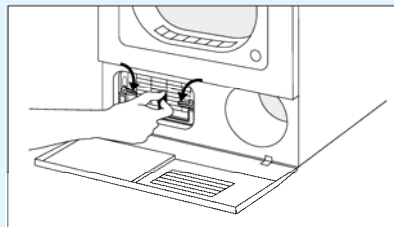

Figure 7.

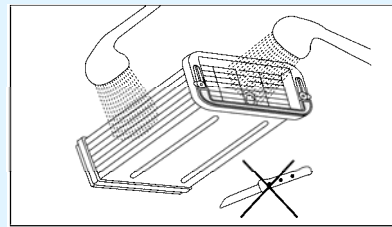

Figure 8.

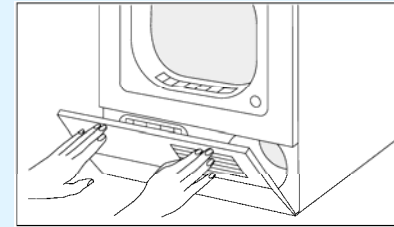
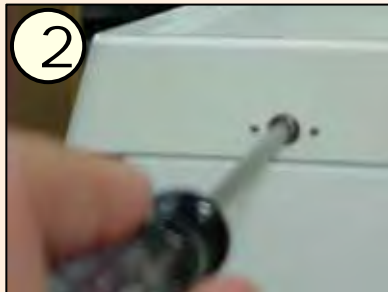
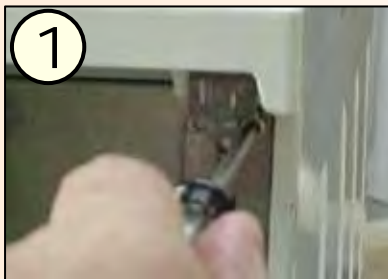

Figure 9.

Disassembly -- Top Panel



To remove top panel to access control module & frame (for disassembly):

- ① Carefully pry out plastic covers over screw on each front side of dryer cover. Then, remove each T-20 Torx screw (total of 2).
- ② *(Optional)* Carefully remove two rear clips from cover by removing T-20 Torx screws.
- ③ When front screws are removed, tilt front of top cover up, then lift white plastic top cover off of dryer.
- ④ To gain access to top of dryer, remove metal top cover by removing seven (7) T-20 Torx screws. Don't forget to remove screws in two white plastic bumpers on front corners.
- **NOTE:** Wiring diagram is contained in a clear plastic sleeve on the metal top cover.



Disassembly -- Fascia Panel



To remove fascia panel to access display module & frame (for disassembly), carefully pry panel toward front of dryer and lift panel up. Don't break plastic tabs.

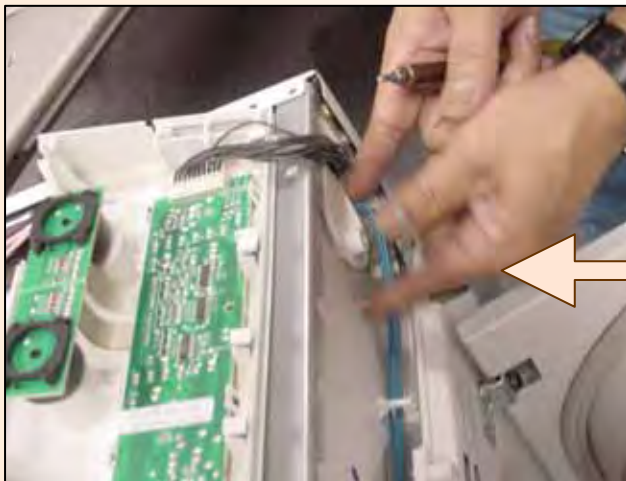

NOTE: Also need to separate wire harness & door latch cable from front panel & display module.



Disassembly -- Rear Panel (for Drum and Rear Access)



To remove rear panel to access heater, NTC R2, Hi-Limit safety cutout, fan & drum rear bearing), remove 12 screws.

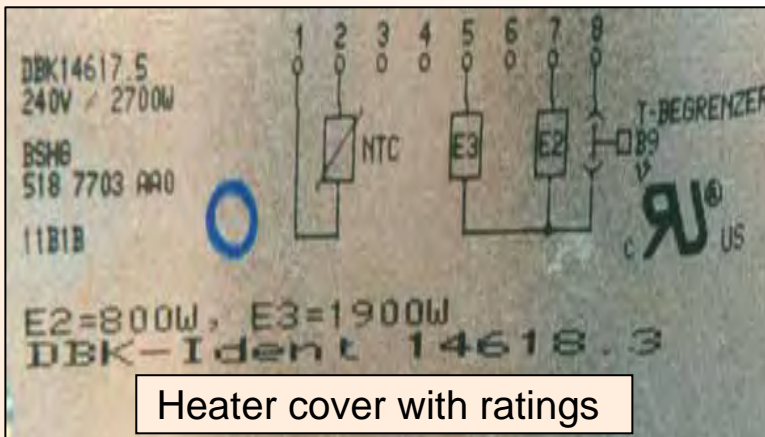

To remove heater, remove heater cover, then remove two (2) screws at top of heater assembly and one (1) screw at wire harness.

NOTE: Heaters cycle on and off as needed to keep temperatures at appropriate levels.

Disassembly -- Front Panel (1) (for Drum and Front Access)

Removing door hinges



Removing front panel screws



HINT: Remove front panel to access drum, display module, R3 NTC & door latch.



To remove front panel, remove three (3) T-20 Torx screws @ top of panel and five (5) T-20 Torx screws around door face frame. See **red** dots for screw locations.

HINT: Carefully pry out white cap to access T-20 Torx screw underneath door.

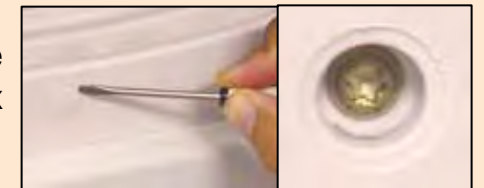

Disassembly -- Front Panel (2) (for Drum and Front Access)



HINT: To remove door latch from front panel, remove two (2) T-10 Torx screws.

NTC R3 in bottom of door face frame

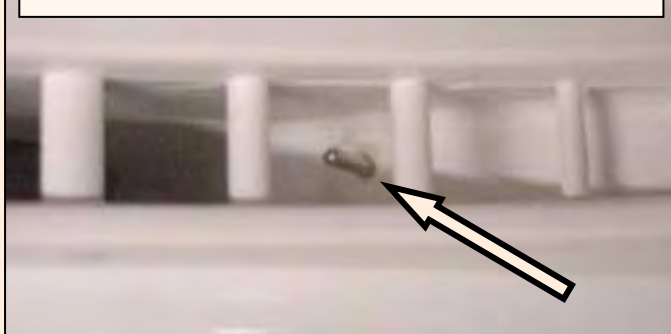

HINT: Remove door latch and disconnect NTC R3 wire harness before removing door face frame (from front panel).

Disassembly -- Side Panels (for Drum and Right Side Access)



**Unscrewing
side panel
screws**



**Removing
side panels**

To remove side panels to access drum & drive motor:

- Remove four (4) T-20 Torx panel screws from rear of dryer.
- Remove one (1) T-20 Torx screw from top front of dryer.
- Then carefully lift panels up and out.

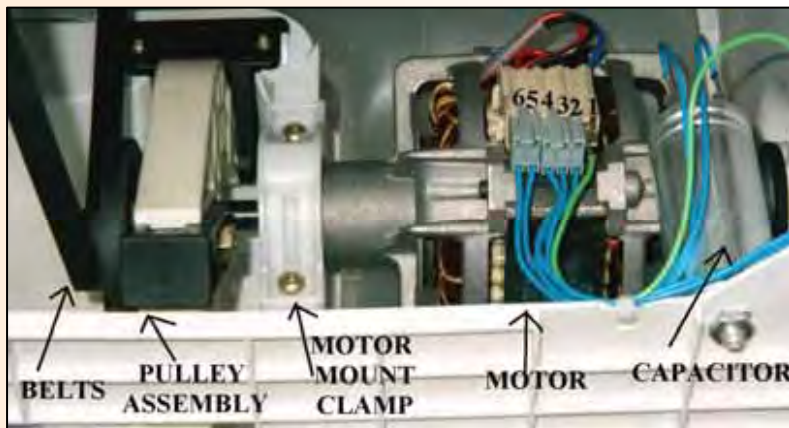

HINT: Remove right side panel to access drum drive motor, belts/pulleys, heater connector & motor capacitor.

Disassembly -- Frame (1)

To access the drum, the frame must be partially disassembled.

TO DISASSEMBLE FRAME (to access drum):

- ① Remove top, fascia & side panels (with door).
- ② Remove drum drive belt.
- See next page for rest of procedure.



To remove inner frame, lift it up and out.

Frame with fascia, front & side panels removed.



To remove belt, remove motor tensioning spring, then slide belt off of front of drum.

Disassembly -- Frame (2)



TO DISASSEMBLE FRAME to access drum (continued):

- ③ After the side panels have been removed, remove one (1) long T-20 Torx screw from the front of the base on each side (total of 2 screws).
- ④ Remove front frame rail screws from front of dryer.
- ⑤ Remove front frame screws from top of dryer.



Disassembly -- Drum (1)



REMOVING DRUM FROM FRAME:

- If not done already, disconnect wire harnesses hindering removing drum and place them out of the way. Leave the control module (with wire harnesses) mounted to the side frame.
- Lift out front panel from frame.
- Remove front frame rails.

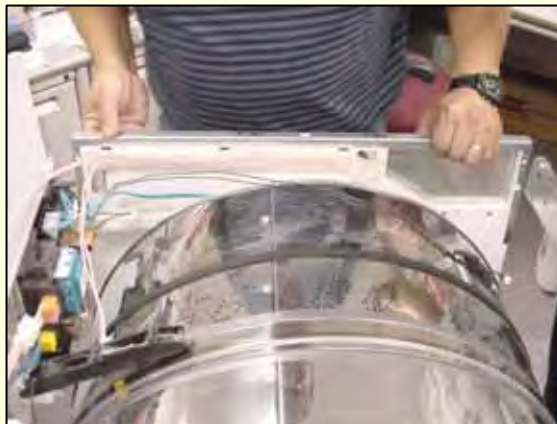
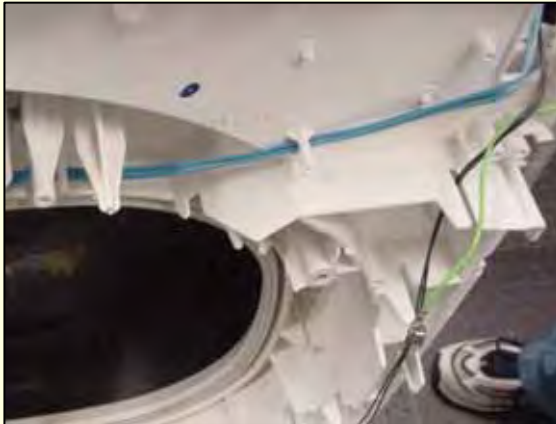

Disassembly -- Drum (2)



REMOVING DRUM FROM FRAME (continued):

- If not done already, remove heater (rear) cover to access rear drum bearing.
- Unscrew main nut on rear bearing to release drum from frame.
- Carefully lift drum out from frame.

HINT: Use a 13mm socket or wrench on the main nut on the rear of the drum.

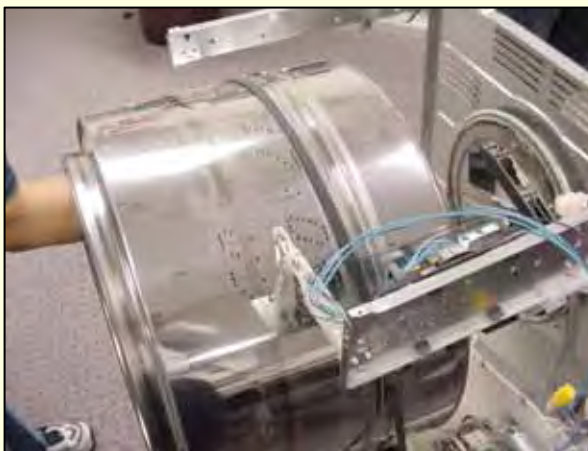

Disassembly -- Drum (3), Rear Bearing

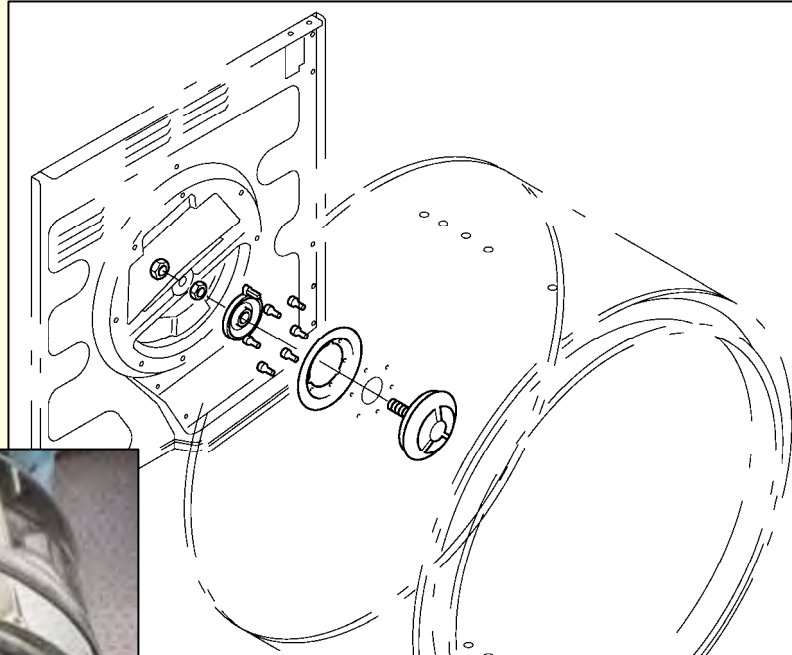

HINT: Some older WTA 3500 & WTL 5400 dryers may have rear bearings without a copper plate & carbon brush (which were added to enhance electrical ground connections). If so, the rear bearing should be replaced with kit # 183897.

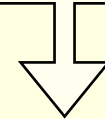

Disassembly -- WTA 35 Drum Drive Motor

To disassemble drum drive motor:

- Remove heater cover on rear of dryer. Remove right side panel.
- Release belt tension spring and small belt.
- Using a 13mm wrench or socket on fan blade and an adjustable wrench on pulley, loosen and remove fan blade from motor shaft.
- Remove ("horseshoe") drum motor clamp by removing two screws.
- Remove belt tensioning mount by removing two screws.
- Disconnect terminal connector from motor.
- Remove motor from dryer.

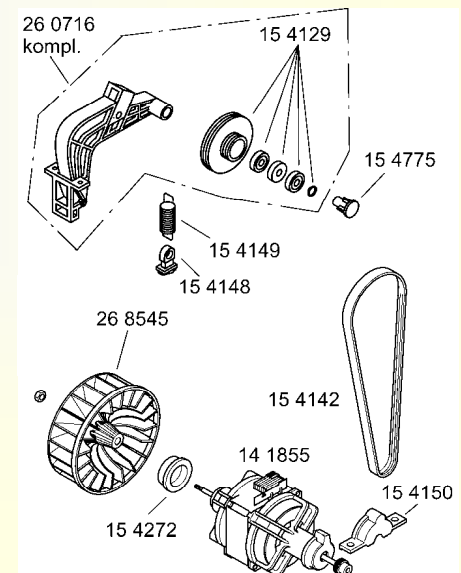
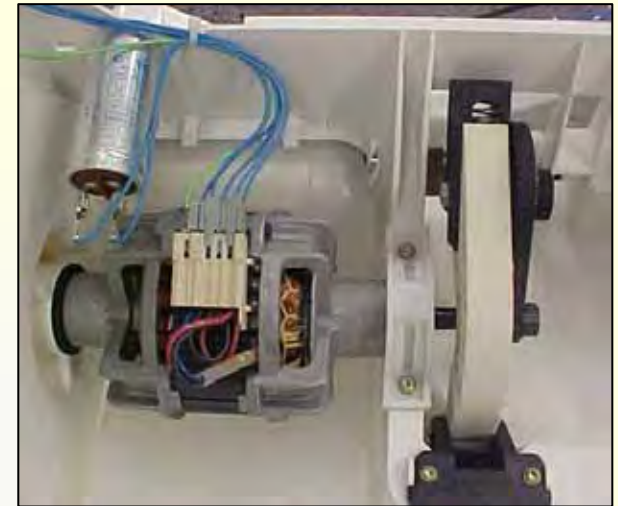

Disassembly -- WTL 54 Drain Pump & Drum Motor (1)



Remove rear cover & right side panel



HINT: Carefully remove rear cover to avoid damaging gasket. Bring a # 167651 gasket for any WTL 54 repair in case gasket gets damaged.

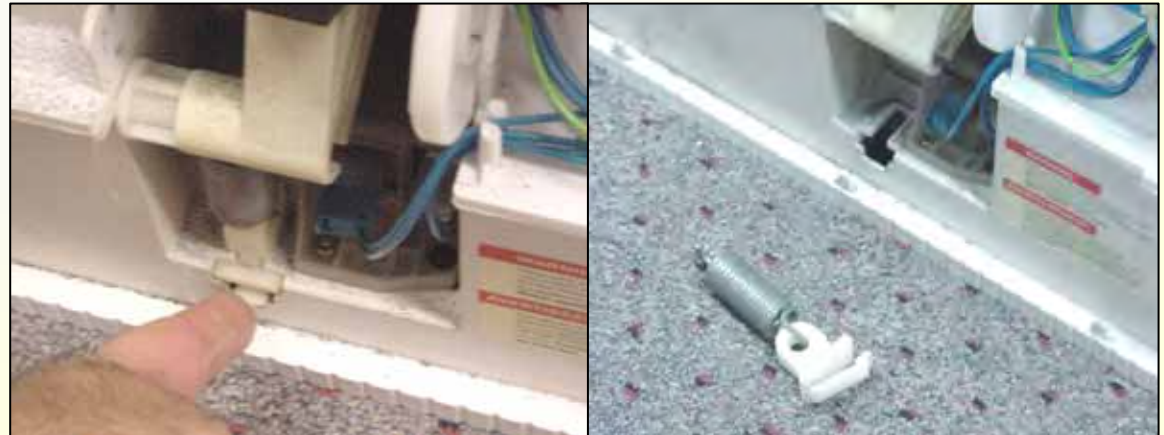

Push latch to unhook spring.

Disassembly -- WTL 54 Drain Pump & Drum Motor (2)



Disconnect drain pump wires



Slide drive belt off pulley



Pull out motor clamp



Drum motor clamp removed



Remove spring holder



Unscrew pump cover screw

Disassembly -- WTL 54 Drain Pump & Drum Motor (3)



Disconnect hose Remove pump cover Disconnect motor wires

Remove drain pump

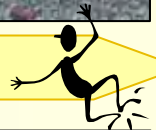

Remove float



Remove rear fan (13mm socket)



Remove front insulation



Disassembly -- WTL 54 Drain Pump & Drum Motor (4)



Remove front fan cover (twist ccw), then remove front fan (while holding motor shaft)



Remove pulley assy. by removing (2) T-20 Torx screws

Disassembly -- WTL 54 Drain Pump & Drum Motor (5)



HINT: Without removing drum, pulley assembly screws access is tight. Use a ratcheting screwdriver for tight locations.



Exposed drum drive motor

Remove drum motor



HINT: If necessary, pry out motors carefully (using wood or a tool which won't damage the dryer).



Push drum drive motor toward rear of dryer.

Disassembled drum drive motor



You're done!!

Disassembly -- WTL 54 Drain Pump & Drum Motor (5)

To disassemble WTL 54 drain pump (quick guide):

- Remove right side panel.
- Remove wire harness from pump.
- Release belt tension.
- Remove spring holder & drum motor clamp.
- Remove black drain hose.
- Remove motor cover, being careful to not to damage water level microswitch.
- Remove drain pump motor and float assembly from dryer.

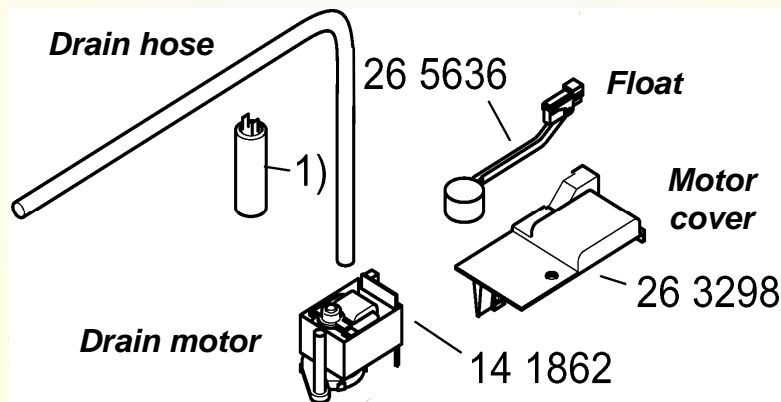

...and that's all there is to taking apart the dryers!

Reassembly -- Rear Main Drum Bearing (1)

HINT: Make sure rear bearing nut is tight -- if not, dryer can squeal when drum turns.

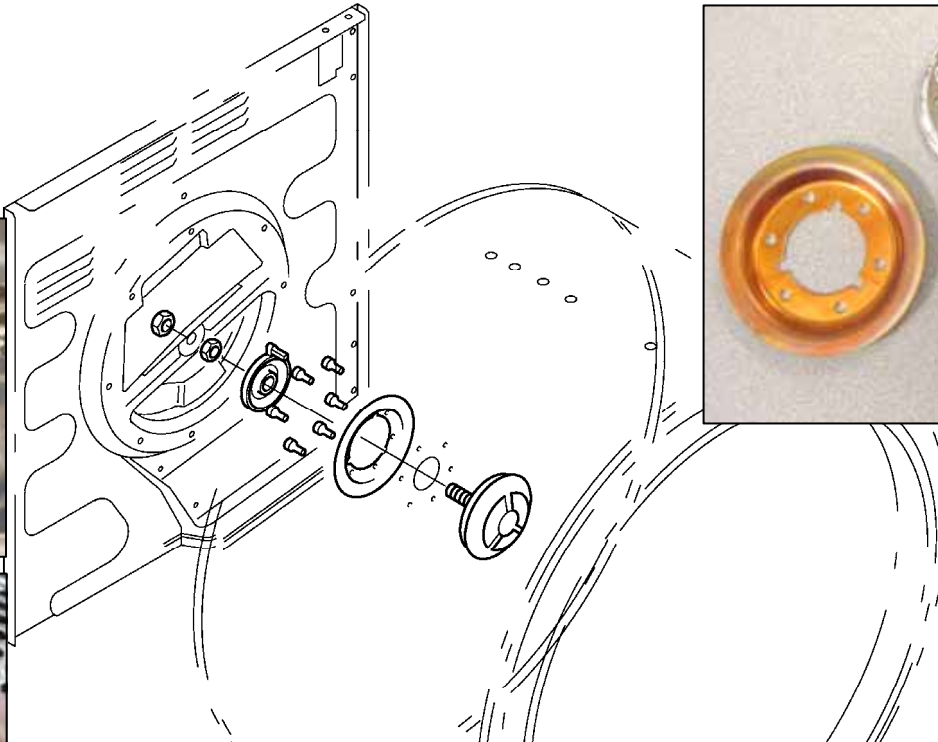
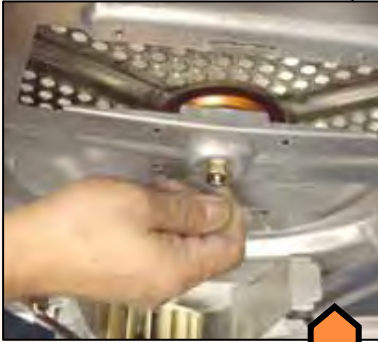

Reassembly -- Rear Main Drum Bearing (2)

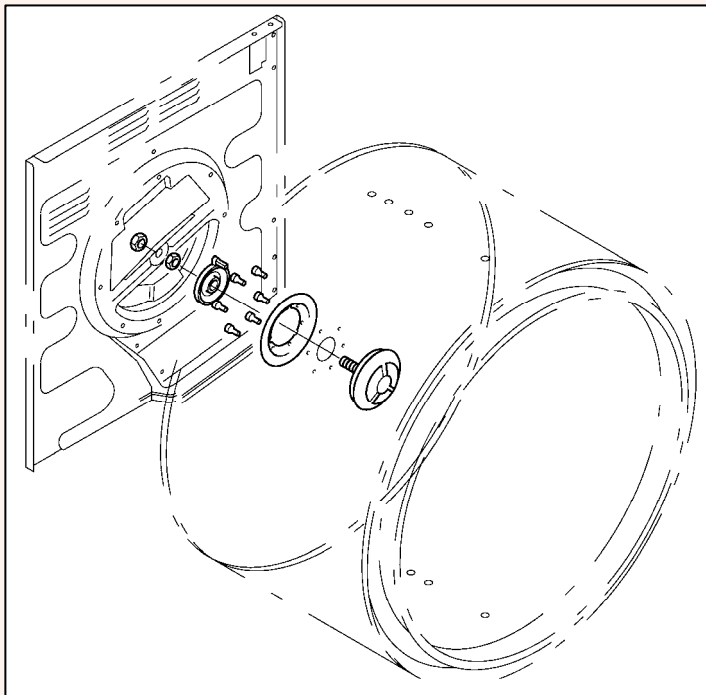

HINT: Rear bearing kit # 183897 includes a copper plate & carbon brush to enhance electrical ground connections.

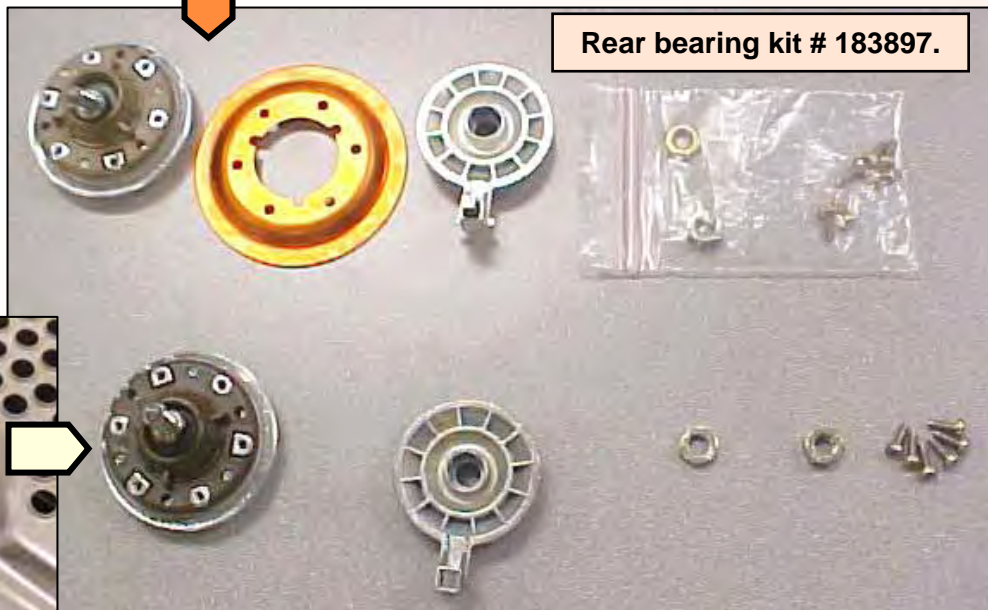

Rear bearing kit # 183897.

HINT: Some older WTA 3500 & WTL 5400 dryers may have rear bearings without a copper plate & carbon brush (which were added to enhance electrical ground connections). If so, the rear bearing should be replaced with kit # 183897.



Reassembly -- Fan, Hi-Limit & NTC R2

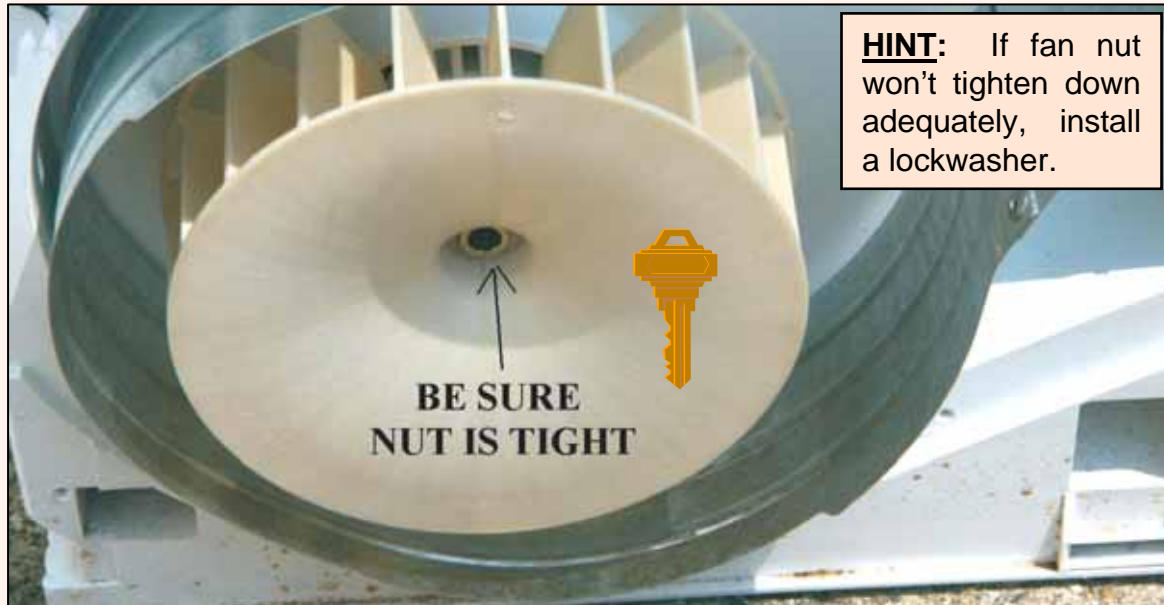

HINT: If fan nut won't tighten down adequately, install a lockwasher.



HINT: On WTL 54 condensation dryers, make sure the rear seal is installed properly to avoid any moisture leaking. Always bring a gasket when doing any WTL 54 repairs.

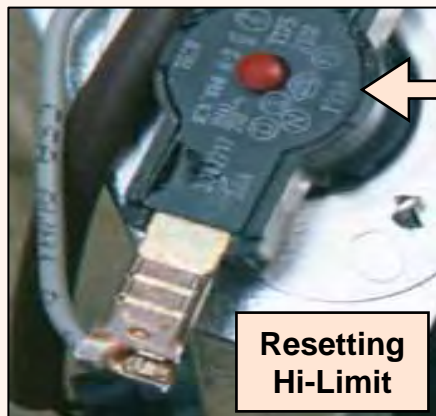

NOTE: Hi-Limit (high temp cutout), located on heater housing, trips @ **212°F (WTA 35)** or **248°F (WTL 54)**. To reset Hi-Limit, press **red** button.

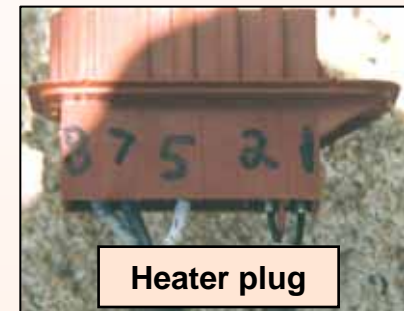

Reassembly -- Control Module Wire Harnesses

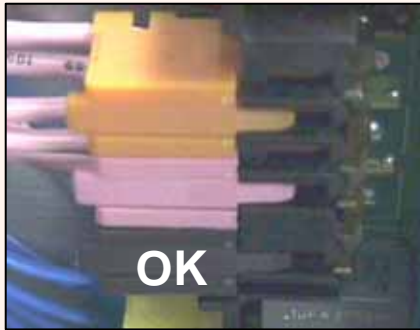

OK

HINT: Make sure there is no gap between the **orange** and **pink** connectors.

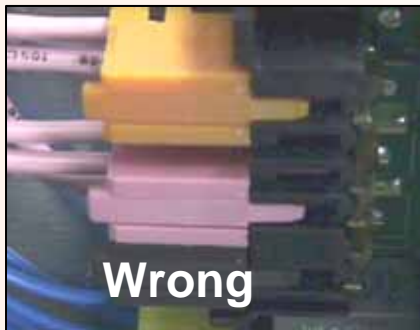

Wrong

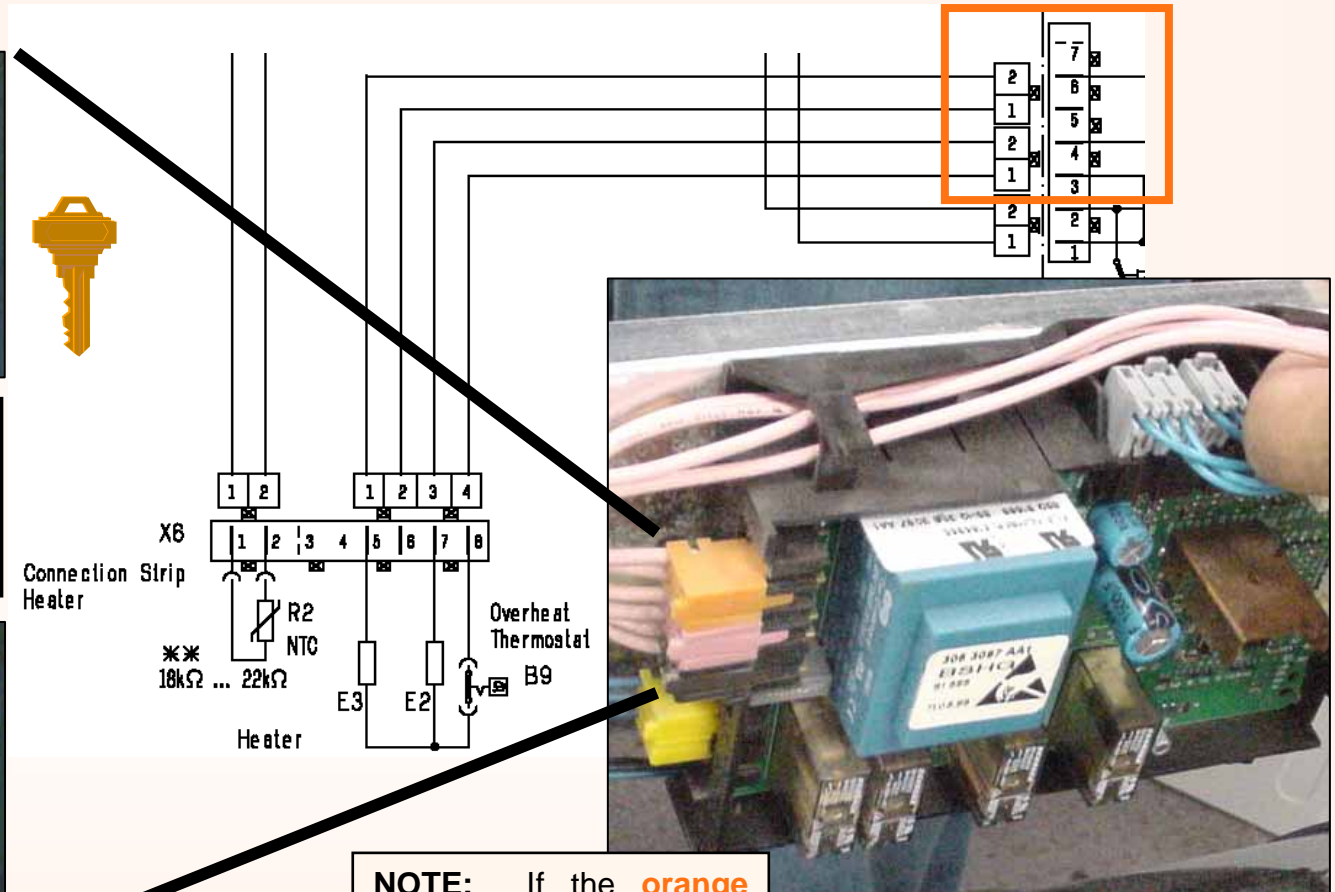

NOTE: If the **orange** connector isn't reattached properly, the E3 heater won't come on.

Reassembly -- Drum Interior Light



Plastic tabs

I've seen the light!



Remove fascia panel (with display module) to access light, taking care not to damage panel plastic tabs (photos 1-3).



Remove light cover (located above door panel next to **On/Off & Door** switch assembly).



Pull out light socket (with connectors) and change light bulb.

Reassembly -- Terminal Box



NOTE: Fuse holders for SC-15 15A fuses aren't available and must be bought locally.

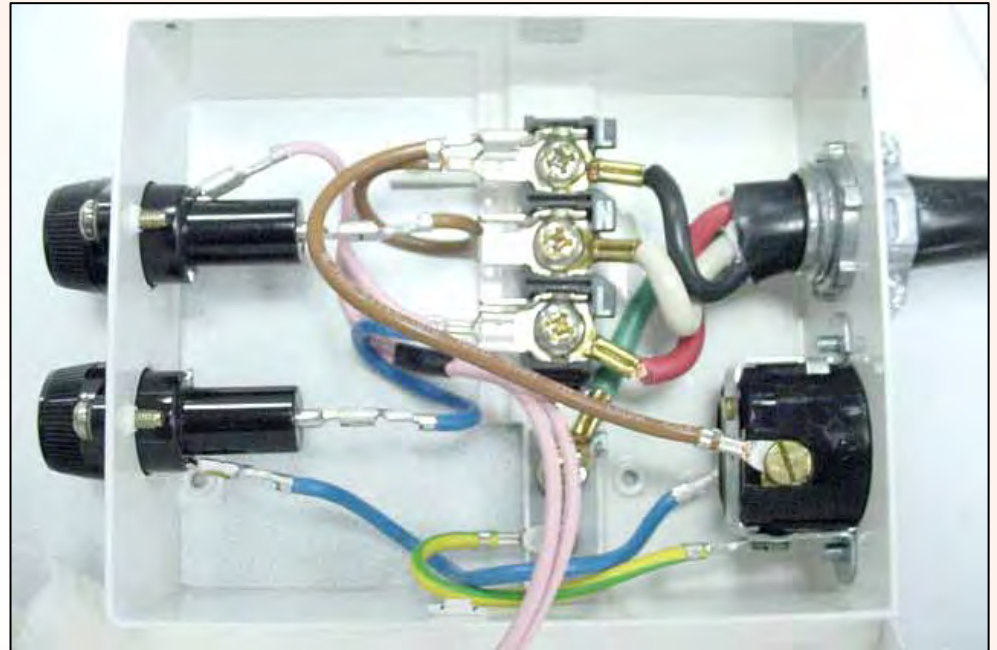

WTA 35/WTL 54 Circuit Diagram

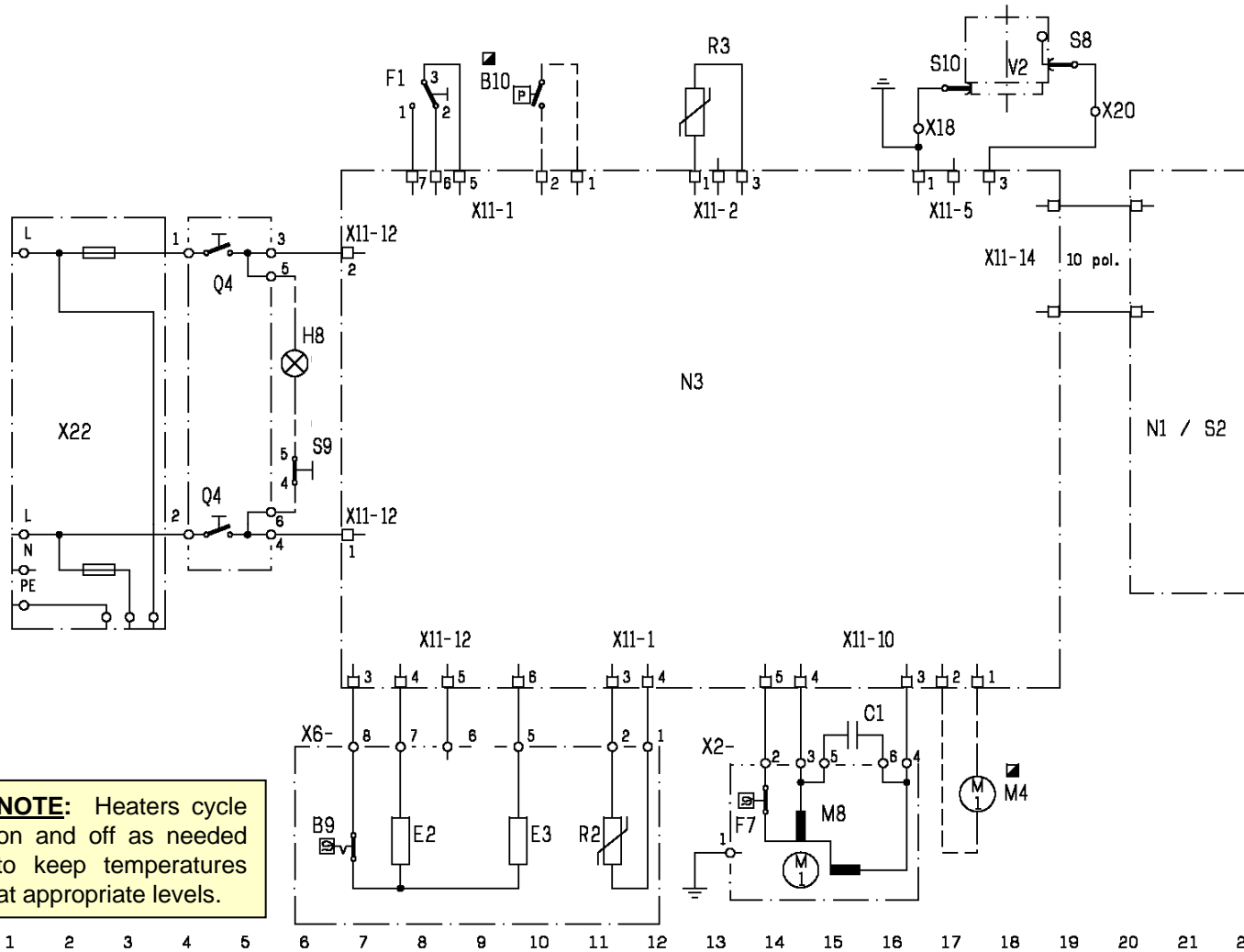

HINT: "Mains" is the European term for "power".

HINT: This circuit diagram is used for WTA 3500UC, WTA 3510UC, WTL 5400UC & WTL 5410UC dryers.

NOTE: Heaters cycle on and off as needed to keep temperatures at appropriate levels.

List of Components	Current Path
B9	Overheat Thermostat 7
B10	Level Switch Condensate Water 10
C1	Capacitor 15
E2	Heater 10
E3	Heater 8
F1	Door Switch 8
F7	Motor Overload 14
H8	Illumination 6
M4	Pump Motor Condensate Water 8
M8	Drum Motor 15
N1	Operating Module 21
N3	Power Module 6-19
Q4	Main Switch On/Off Switch 4
R2	NTC Temperature Sensor 11
R3	NTC Temperature Sensor 13
S2	Selector Switch 21
S8	Sliding Contact-Conductance 19
S9	Door Switch 6
S10	Sliding Contact earth 17
V2	Electrode Conductance 18
X2	Motor Connector Plug 13-16
X6	Connection Strip Heater 7-11
X11	Plug in Connection Module 6-22
X18	Connector 16
X20	Connector 20
X22	Mains Connection Box 2

■ effective for appliances with condensation drying system (WTL 5400 UC & 5410UC)

WTA 35 /WTL 54 Wiring Diagram

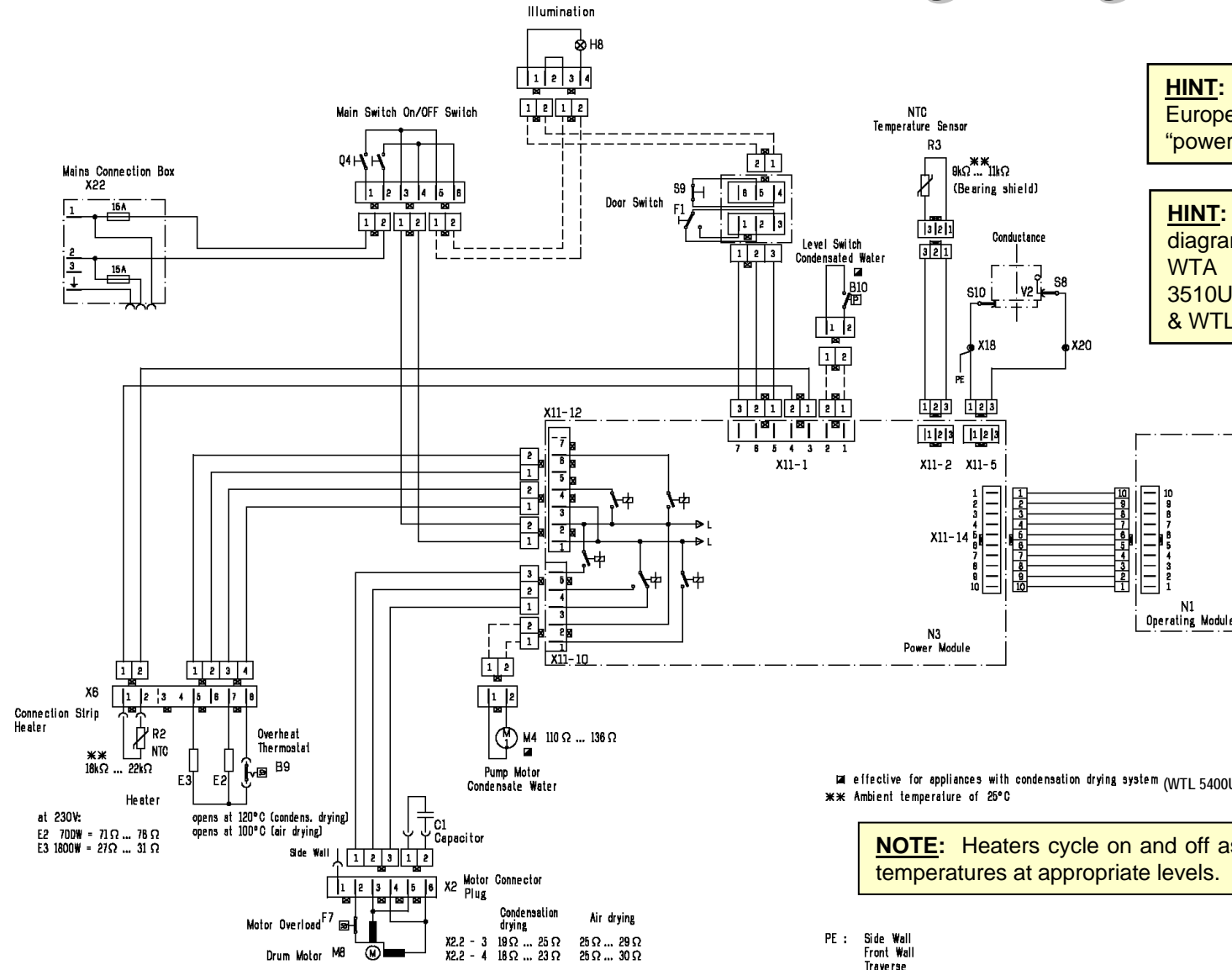

HINT: "Mains" is the European term for "power".

HINT: This wiring diagram is used for WTA 3500UC, WTA 3510UC, WTL 5400UC & WTL 5410UC dryers.

☑ effective for appliances with condensation drying system (WTL 5400UC & WTL 5410UC)
 ※※ Ambient temperature of $26^\circ C$

NOTE: Heaters cycle on and off as needed to keep temperatures at appropriate levels.

PE : Side Wall
 Front Wall
 Transverse

WTA 35 & WTL 54 Service Tips -- Ratings

- Rated 240VAC, 15A, 60 Hz (uses 13A max.).
- Uses 15A type SC-15 fuses (for washer & dryer).
- Uses NEMA 14-30P 240V, 30A, 4-wire plug, which mates to a NEMA 14-30R outlet. Can use NEMA 10-30P 3-wire cord (bought locally) if needed to match NEMA 10-30R outlet.
- WTL 54 max. drain hose length = 15' (180") & max. drain hose height = 3-1/2' (43").
- WTA 3510 & WTL 5410 dryers are similar to WTA 3500 & WTL 5400 dryers (except for enhanced fascia styling & Spanish/French fascia inserts).
- Output with clean lint filter = 112 cfm. (with dirty lint filter = 83 cfm).
- UL listed (U.S. & Canada)



HINT: This service training manual can be used to service WTA 3500 & WTL 5400 dryers.

WTA 35 Service Tips -- Drum Drive Motor

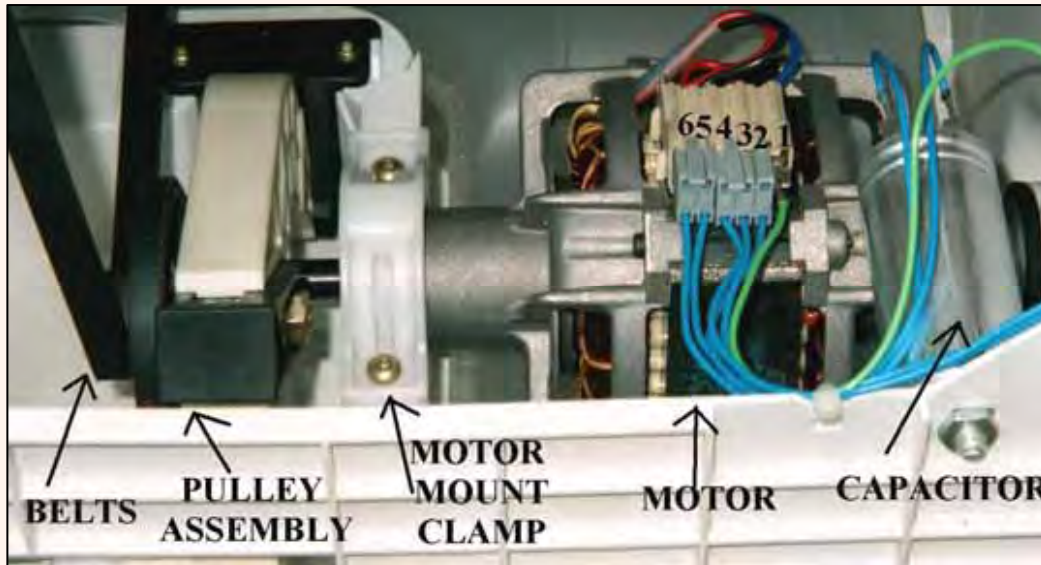

Replacing drive belt

HINT: Remove right side panel to access drum drive motor, belts/pulleys, heater connector & motor capacitor.

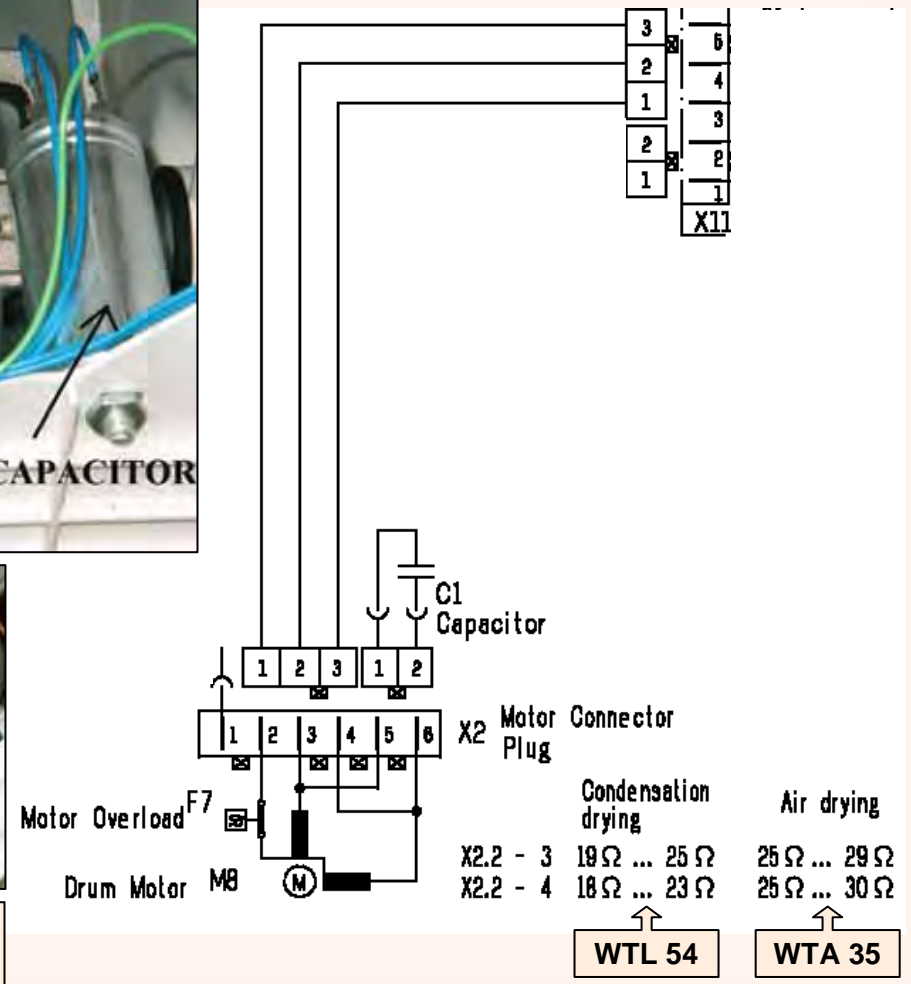

WTL 54 Service Tips -- Drum Drive Motor

Drum drive motors on WTL 54 condensation dryers are different and are installed differently than WTA 35 vented dryers to avoid water leaking, provide space for the drain pump and provide a condenser fan.

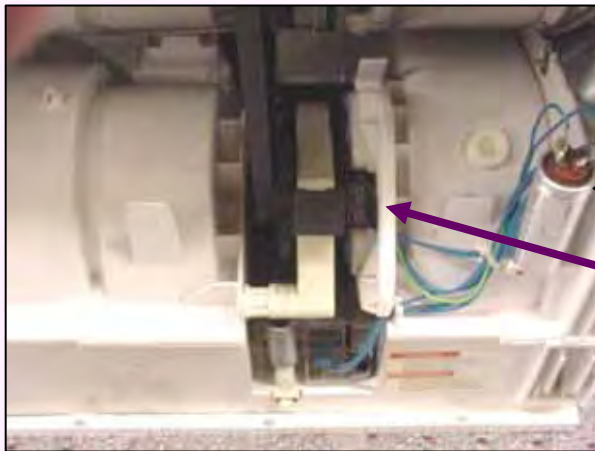

Motor capacitor

Motor connector plugs

CAUTION: When installing WTL 54 drum drive motors, be careful to not damage cover seal to prevent water leakage.

HINT: Remove right side panel to access drum drive motor, belts/pulleys, heater connector & motor capacitor.

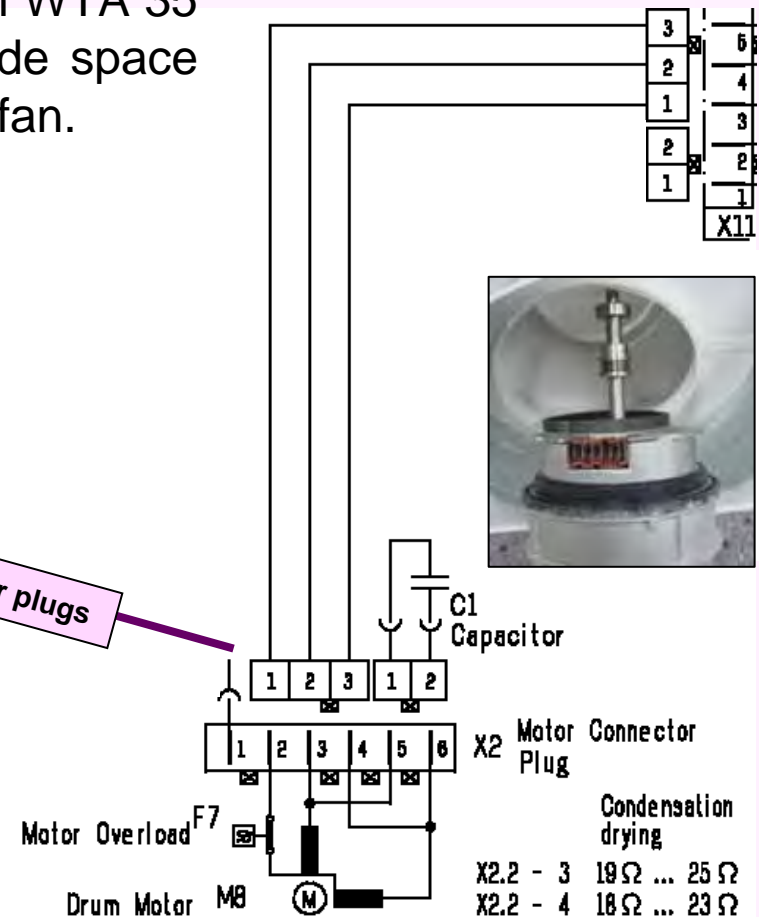

WTL 54 Service Tips -- Pump Motor

WTL 54 condensation dryers have drain pumps to eliminate the condensed water.



HINT: Remove right side panel to access pump motor.

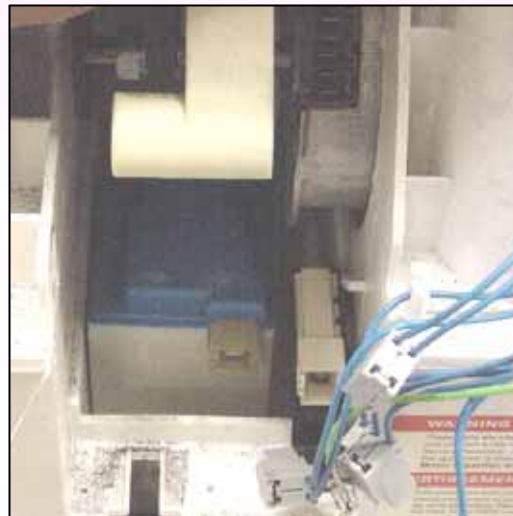

HINT: Pump motor resistance measurement is ~ 110 - 136Ω.

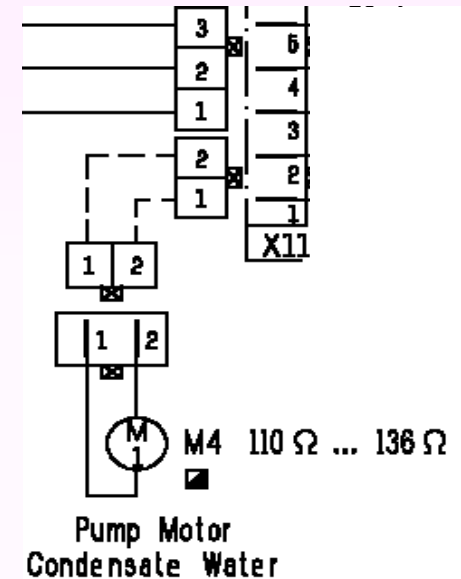

Drain hose connection on right rear of dryer.

WTA 35 & WTL 54 Service Tips -- NTC R2, Hi-Limit & Heater

HINT: NTC R2 reads ~ 21 kΩ @ room temperature.

NOTE: Heaters cycle on and off as needed to keep temperatures at appropriate levels.

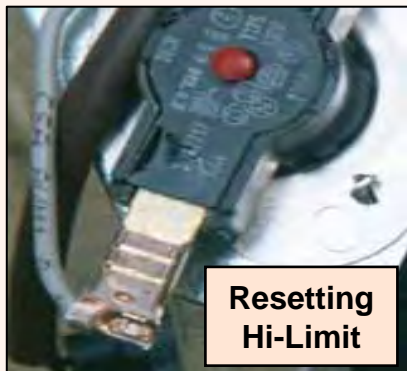
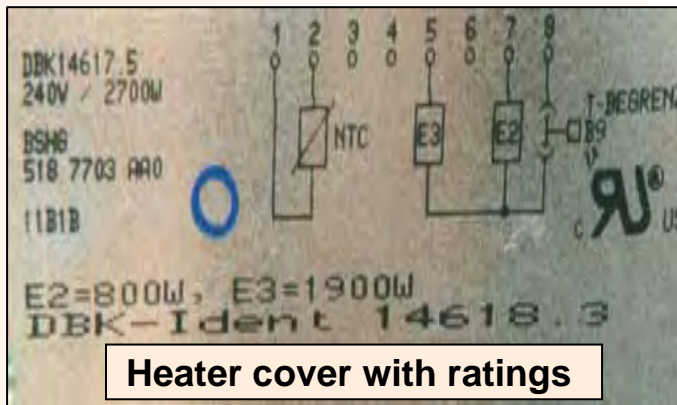

HINT: Measure heater E3 between terminals 8 & 5 and heater E2 between terminals 8 & 7. If resistance = ∞, reset Hi-Limit thermostat and remeasure.

HINT: Hi-Limit (safety cutout) trips @:

- 100°C (212°F) for WTA 35
- 120°C (248°F) for WTL 54

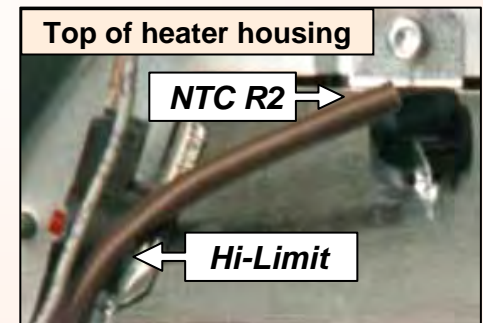
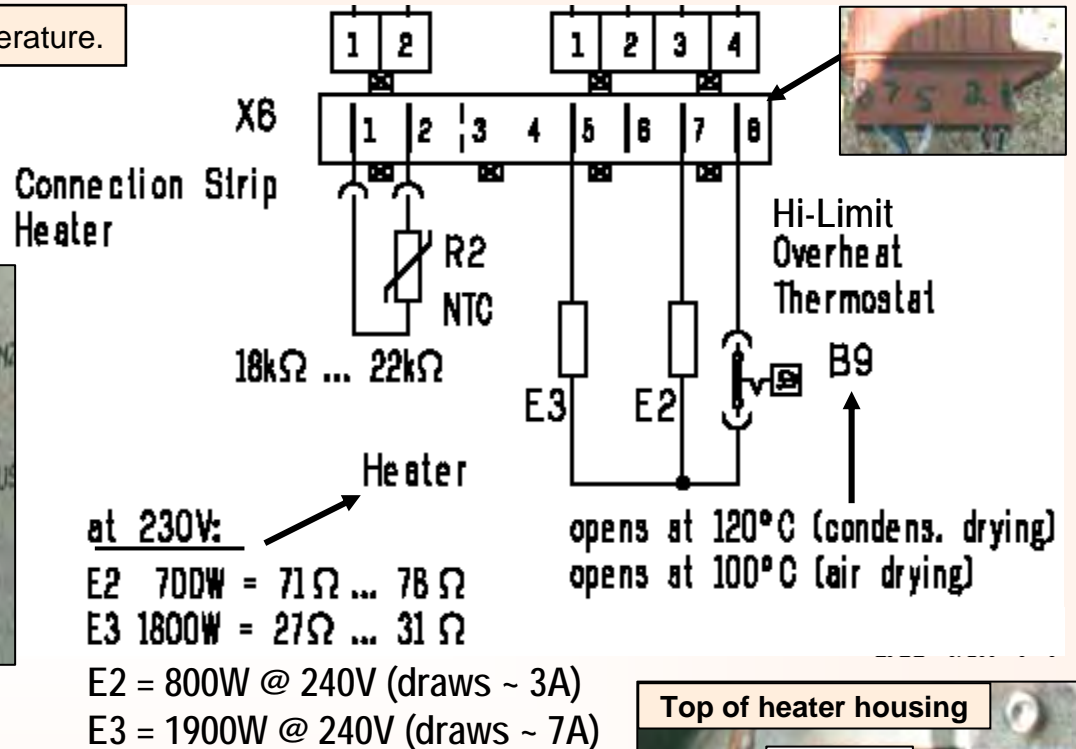

WTA 3500/3510 UC/13 Service Tips -- Timed Dry 🕒

WTA 3500/3510 UC/13 vented dryers have *Timed Dry* cycles which use less energy than WTA 3500 UC/04 - UC/10 dryers (to meet Canadian energy requirements). These dryers can take longer to dry laundry during *Timed Dry*. This doesn't affect WTL 54 condensation dryers -- they do not have a reduced heat output during *Timed Dry* cycles.

The *Timed Dry* cycles are intended for drying delicates and hand washables. When drying cotton and permanent press fabrics, *Auto-cycles* (i.e. sensor controlled drying) should be used. Using *Auto-cycles*, WTA 3500/3510 UC/13 vented dryers heat to full capacity and sense when clothes are dry, drying clothes quickly and safely.



NOTE: WTA 3500 UC/04, UC/08 & UC/10 dryers used control module # **265677**, which provided full heating during *Timed Dry*.

NOTE: WTA 3500 & WTA 3510 UC/13 dryers use control module # **481590**, which provides reduced heating during *Timed Dry* to meet Canadian energy requirements.

WTA 35 Service Tips -- Whistling Dryers

WTA 3500/3510 vented dryers can occasionally whistle if one or more of the vent covers has worked loose or wasn't installed securely.



To eliminate whistling from WTA 35 vented dryers, reattach vent covers to dryers with silicone caulk. Use a non-adhesive type which will allow vent covers to be moved at a later date.

HINT: Use silicone caulk to fasten vent covers whenever installing or repairing WTA 35 vented dryers.

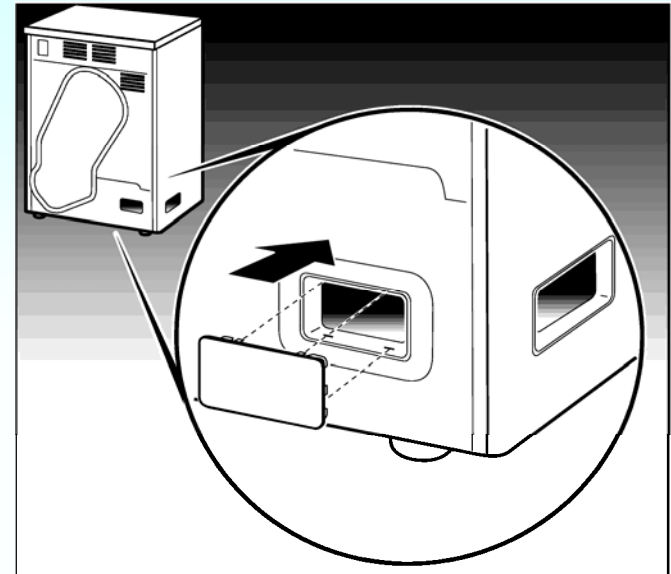

WTA/WTL Service Tips -- Test Program (1)

WTA 35 & WTL 54 dryers have test programs enabling them to self-diagnose problems, including listing the last fault code.

To enter/exit test program for WTA 35 & WTL 54 dryers:

- ◆ Rotate *Auto-cycle* and *Timed cycle* knobs to **Off** position.
- ◆ Push and hold **Start** and **Delicate** buttons at the same time, then turn dryer on by pushing **On/Off** button. After pushing **On/Off** button, keep holding **Start** and **Delicate** buttons until **Start** light flashes rapidly. Dryer is now in the test program.
- ◆ Lights will flash for drying faults -- fault shown will be the last fault code on the dryer (see fault chart on next page).
- ◆ When test program has been entered:
 - ◆ **Start** light flashes rapidly.
 - ◆ Select individual parts to test by rotating *Auto-cycle* knob as shown on next page.
 - ◆ Don't rotate *Auto-cycle* knob or push any button while individual tests are being run (so tests won't stop).
 - ◆ Once part to test has been selected, start test by pushing **Start** button. **Start** light will stay on continually while tests are running. Push **Start** button again to end any test. Tests have finished once **Start** light flashes rapidly again.
 - ◆ To exit test program, push **Start** button (while **Start** light flashes rapidly).



NOTE: Fault displayed will be 1st fault that occurred since last time dryer was turned on.

WTA/WTL Service Tips -- Test Program (2)

Test parts individually as follows:

- ◆ **Indicating lights & digital display** – To start test, rotate *Auto-cycle* knob to **Regular/Cotton Extra Dry**, then push **Start** button. To end test, rotate *Auto-cycle* knob out of **Regular/Cotton Extra Dry** position.
- Cycle buttons & selector switches** – To start test, rotate *Auto-cycle* knob to **Regular/Cotton Very Dry**, then push **Start** button. To end test, push **Start** button again (since test doesn't end).
- ◆ **Pump, motor, heater & NTC's** – To start test, rotate *Auto-cycle* knob to **Regular/Cotton Regular Dry**, then push **Start** button. Test ends automatically.
- ◆ **Sensor conductance** – To start test, rotate *Auto-cycle* knob to **Regular/Cotton Light Dry**, then push **Start** button. To end test, push **Start** button again (since test doesn't end).

Fault	Possible Causes	Flashing Lights	Digital Display
Drying time too long	<input type="checkbox"/> Control module failed. <input type="checkbox"/> Moisture sensor(s) failed. <input type="checkbox"/> Hi-Limit ("overheat") thermostat tripped and failed to reset. <input type="checkbox"/> Water level switch failed (WTL 54 only). <input type="checkbox"/> Supply voltage too low.	● Anti-Crease/End	
Overheating	<input type="checkbox"/> Control module failed. <input type="checkbox"/> Heater failed.	● Extra Dry	
R3 NTC failed (short or open circuited)	<input type="checkbox"/> NTC # R3 failed.	● Damp Dry	
R2 NTC failed (short or open circuited)	<input type="checkbox"/> NTC # R2 failed.	● Regular Dry	
Condensed water not pumped out (WTL 54 condensation models only)	<input type="checkbox"/> Pump failed.		E1

WTA/WTL Service Tips -- Test Program (3)

SELECTOR KNOB	KNOB PROGRAMS	KNOB POSITION	LIGHTS					
			Drying	Damp Dry	Regular Dry	Extra Dry	Anti-Crease/End	
Program Selector Knob NOTE: Red <i>Regular/Cotton Very Dry</i> lights stay lit during this test no matter what program selector position is chosen – no other <i>Regular/Cotton</i> or <i>Permanent Press</i> lights comes on.	Off							
	Regular/Cotton Extra Dry		On					
	Regular/Cotton Very Dry			On				
	Regular/Cotton Regular Dry				On			
	Regular/Cotton Light Dry					On		
	Regular/Cotton Econo Dry						On	
	Regular/Cotton Damp Dry		On	On				
	Permanent Press Econo Dry		On		On			
	Permanent Press Light Dry		On			On		
	Permanent Press Regular Dry		On				On	
	Permanent Press Very Dry			On	On			
Permanent Press Extra Dry			On		On			
Timed Cycle Knob NOTE: <i>program selector knob MUST</i> be straight up for tests to run.	Timed cycle Heated Dry			On			On	
	Timed cycle				On	On		
	Timed cycle				On		On	
	Timed cycle Air Fluff					On	On	

Cycle Buttons & Selector Switches Test Chart

NOTES:

- Pushing "START" button after test has ended will repeat it.
- Door can be opened (if desired) during this test.
- *Delicates, End of Cycle Signal* and *Cycle Time Minutes* lights stay lit whenever button underneath them is pushed and held.
- Digital display does not come on during this test.



WTA/WTL Service Tips -- Test Program (4)

Pump, motor, heater & NTC's Test Sequence Chart

PART TESTED	TEST ORDER & TIME (SECONDS)															NOTES			
	START	15				5	2	5	29								END		
		3	5	5	2			5	1	5	1	5	1	5	1			5	
Pump	START OF TEST																	END OF TEST	For WTL 54 condensation dryer only
Motor – right rotation																			During 29 second drum reversing cycle, drum runs for 5 seconds on / 1 second off – check drum rotation with door open.
Motor – off																			
Motor – left rotation																			
Heater (E2)																			
Heater (E3)																			Feel for heat with door open.

NOTES:

- Test ends automatically. Pushing **Start** button after test has ended will repeat it.
- Opening door stops test – closing door resumes test. To check if drum is turning and if heat is coming out of drum, run test with door open by tripping door latch (by gently pushing it with a screwdriver).

To exit test program (from any test), turn unit off by pressing "**ON/OFF**" button.

WTA/WTL Service Tips -- Test Program (5)

Sensor Conductance Test

HINTS:

- Tests can be run with door closed. Opening door during testing stops the test.
- To run 2nd test with sensors and drum connected, remove top panel and connect jumper to copper braids (for two "brushes" touching outside of drum).
- Drum **must** be empty during these tests – damp clothes in drum will give wrong results.
- Lights won't flash during this test.

To exit test program (from any test), turn unit off by pressing "**ON/OFF**" button.

LIGHTS SHOWING CONDUCTANCE OF MOISTURE SENSORS

Test	"Drying" light	"Damp Dry" light	Comments
Drum empty –sensors and drum not connected	<input checked="" type="radio"/> Drying	<input type="radio"/> Damp Dry	No fault
	<input type="radio"/> Drying	<input type="radio"/> Damp Dry	Fault – short circuit
Drum empty – with sensors and drum connected	<input type="radio"/> Drying	<input checked="" type="radio"/> Damp Dry	No fault
	<input type="radio"/> Drying	<input type="radio"/> Damp Dry	Fault – open circuit or circuit resistance is too high

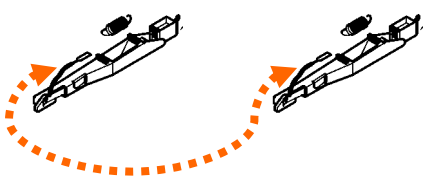

HINT: Using the test program can cut down repair times & eliminate repeat calls from misdiagnosing problems. The pump, motor, heaters, NTC's and moisture sensor conductance tests are more helpful than the buttons, knobs, lights and display tests.

WTA 35 & WTL 54 Service Tips --

Troubleshooting of Minor Faults (Customer Self-Help 1)

SELF-HELP

Dryers may exhibit problems that are unrelated to a malfunction of the dryer itself. The following table may serve to answer your question about a problem you are having without having to call a serviceman.

PROBLEM	POSSIBLE CAUSE
"On/Off" Indicator light does not come on.	<ul style="list-style-type: none"> • The "On/Off" button has not been depressed. • A fuse may have blown or a circuit breaker tripped. Replace fuse or reset circuit breaker at your fuse box/breaker box. • The plug is not correctly or only loosely inserted into the receptacle.
Dryer does not start.	<ul style="list-style-type: none"> • Cycle has not been selected. • "Start" button has not been depressed. • Door is not closed properly. • Room temperature is below 32 °F (0 °C) • If necessary, switch the machine off and wait 5 seconds before switching it on again. Select the cycle again and depress "Start".
Cycle is interrupted and "Lint Filter" light is illuminated and buzzer sounds.	<ul style="list-style-type: none"> • Clean Lint Filter as described in section titled CARE and CLEANING. • (WTA models) Check exhaust vent to see if it is blocked or too long. • (WTL models) Clean heat exchanger as described in section titled CARE and CLEANING. • (WTL models) Check air inlet to make sure it is not blocked.
Cycle is interrupted, buzzer sounds, one or several cycle indicators are flashing.	<p>Indicates faulty operation:</p> <ul style="list-style-type: none"> • Clean the Lint Filter, check the exhaust duct length (WTA models), • Switch the dryer off, wait for it to cool down and then restart.
Drying level not reached or drying time too long.	<ul style="list-style-type: none"> • Clean the Moisture sensors in the drum as described in section titled CARE and CLEANING. • If there is a power failure for an extended period the cycle must be restarted.

WTA 35 & WTL 54 Service Tips --

Troubleshooting of Minor Faults (Customer Self-Help 2)

PROBLEM	POSSIBLE CAUSE
The laundry is not dry even though the highest drying level has been selected.	<ul style="list-style-type: none"> • The drum is too full. • The laundry was too wet when placed in the dryer. • The room is not adequately ventilated. Make sure there is an adequate supply of fresh air. • The lint filter is blocked and should be cleaned. • (WTA models) The exhaust vent is blocked or too long. • (WTL models) The air inlet is blocked.
Drum light does not work	<ul style="list-style-type: none"> • “On/Off” button has not been pressed. • Bulb has failed. For safety reasons the bulb must only be replaced by an authorized service agent.
Following items apply only to the WTL (Condensation Electric Dryer) models	
Cycle is interrupted and “E1” appears in display	<ul style="list-style-type: none"> • Condensate hose is blocked in some way. Turn off dryer and check hose.
Humidity level in room increases greatly	<ul style="list-style-type: none"> • The room is not adequately ventilated. Make sure there is an adequate supply of fresh air. • Check air inlet to see if it is blocked. • The heat exchanger was removed but not replaced.

WTA 35 & WTL 54 Service Tips -- Resistance Measurements from Control Module (1)

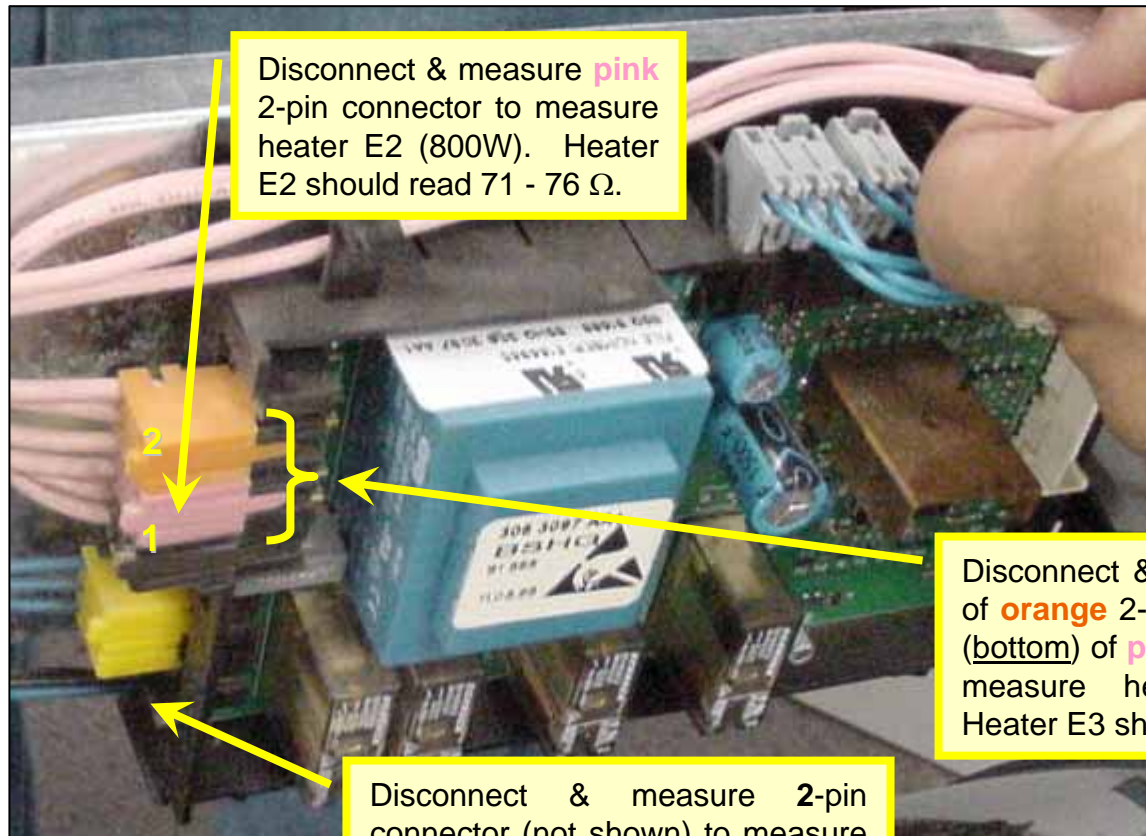

Disconnect & measure **pink** 2-pin connector to measure heater E2 (800W). Heater E2 should read 71 - 76 Ω .

Disconnect & measure pin 2 (top) of **orange** 2-pin connector & pin 1 (bottom) of **pink** 2-pin connector to measure heater E3 (1900W). Heater E3 should read 27 - 31 Ω .

Disconnect & measure 2-pin connector (not shown) to measure drain pump (WTL 54 models). Pump should read ~ 110 - 136 Ω



WARNING!
Unplug dryer before making any resistance measurements.

WTA 3510
model shown

WTA 35 & WTL 54 Service Tips -- Resistance Measurements from Control Module (2)

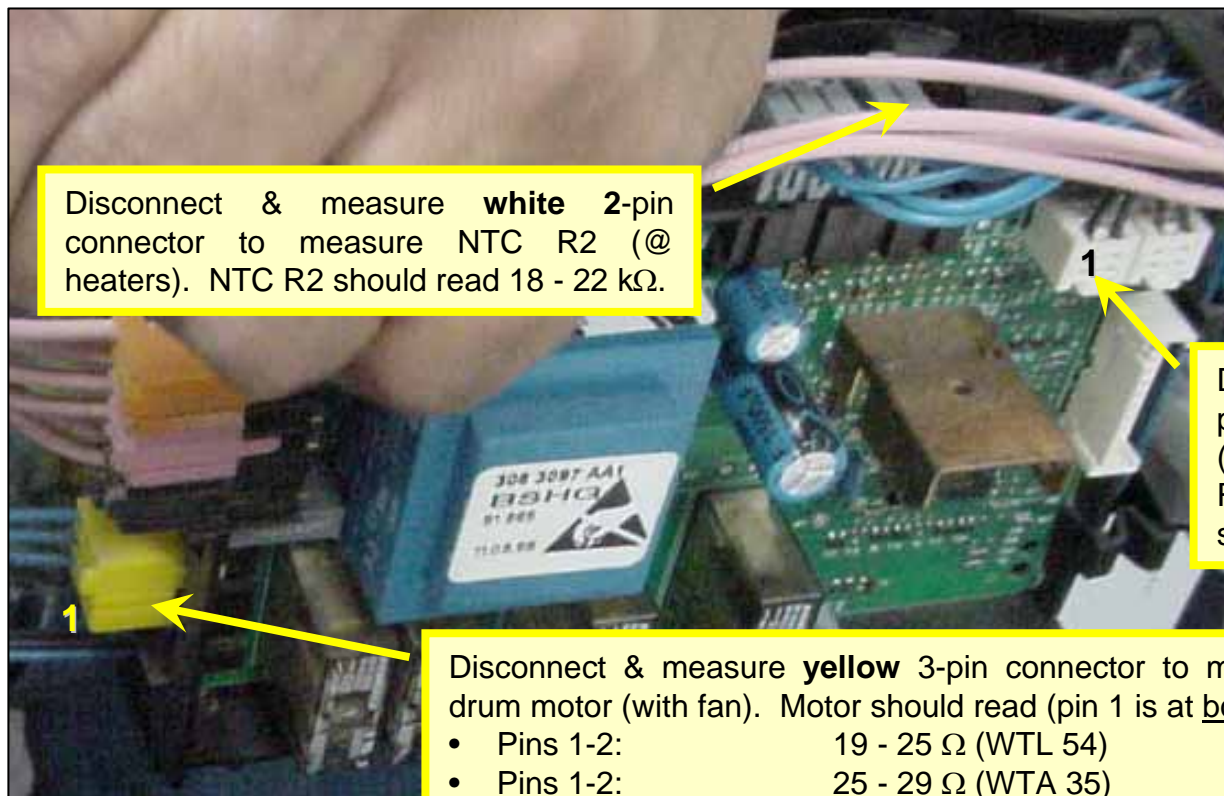

Disconnect & measure **white** 2-pin connector to measure NTC R2 (@ heaters). NTC R2 should read 18 - 22 k Ω .

Disconnect & measure **white** 3-pin connector between pins 1-3 (pin 1 is at left) to measure NTC R3 (@ door frame). NTC R3 should read 9 - 11 k Ω .

Disconnect & measure **yellow** 3-pin connector to measure drum motor (with fan). Motor should read (pin 1 is at bottom):

- Pins 1-2: 19 - 25 Ω (WTL 54)
- Pins 1-2: 25 - 29 Ω (WTA 35)
- Pins 1-3: 18 - 23 Ω (WTL 54)
- Pins 1-3: 25 - 30 Ω (WTA 35)

WTA 3510
model shown

WARNING! Unplug dryer before making any resistance measurements.

WTA 35 & WTL 54 Service Tips -- Troubleshooting (1)

<i>Fault code</i>	<i>Problem</i>	<i>Possible Cause</i>	<i>Solution</i>
<i>Damp Dry light flashes</i>	<input type="checkbox"/> NTC # R3 (@ bearing shield) failed NOTE: When viewing wiring diagram, see NTC # R3.	<input type="checkbox"/> NTC (temperature sensor) failed.	<input type="checkbox"/> Check voltage at and wiring to NTC. Turn off dryer, measure NTC resistance and replace faulty NTC. NOTE: NTC resistances: <ul style="list-style-type: none"> ▪ 9 – 11 kΩ @ 59°F – 221°F
<i>Regular Dry light flashes</i>	<input type="checkbox"/> NTC # R2 (@ heaters) failed NOTE: When viewing wiring diagram, see NTC # R2.	<input type="checkbox"/> NTC (temperature sensor) failed.	<input type="checkbox"/> Check voltage at and wiring to NTC. Turn off dryer, measure NTC resistance and replace faulty NTC. NOTE: NTC resistances: <ul style="list-style-type: none"> ▪ 18 – 22 kΩ @ 59°F – 392°F
<i>Extra Dry light flashes</i>	<input type="checkbox"/> Heater (dryer overheated)	<input type="checkbox"/> Lint filter blocked. <input type="checkbox"/> Vent is blocked or vent hose is too long (WTA 35). <input type="checkbox"/> Dryer is overloaded with laundry. <input type="checkbox"/> Fan impeller has loosened.	<input type="checkbox"/> Clean lint filter. <input type="checkbox"/> Clean vent and vent hose. If vent hose is too long, shorten hose. <input type="checkbox"/> Empty clothes from dryer. <input type="checkbox"/> Tighten fan impeller. If fan impeller cannot be tightened, replace it.

WARNING! Unplug dryer before starting any repairs.

WTA 35 & WTL 54 Service Tips -- Troubleshooting (2)

<i>Fault code</i>	<i>Problem</i>	<i>Possible Cause</i>	<i>Solution</i>
<p>Extra Dry light flashes</p> <p>(continued)</p>	<p><input type="checkbox"/> Heater (dryer overheated)</p>	<p><input type="checkbox"/> Heater failed.</p> <p><input type="checkbox"/> Drum motor failed (or drum drive belt has broken).</p>	<p><input type="checkbox"/> Check voltage at and wiring to heater. Turn off dryer, measure heater resistance and replace faulty heater.</p> <p>NOTE: Heater resistances:</p> <ul style="list-style-type: none"> ▪ 62 – 67 Ω (800W - E2 on wiring diagram) ▪ 25 – 29 Ω (1900W – E3 on wiring diagram) <p><input type="checkbox"/> Check voltage at and wiring to drum motor. Turn off dryer, measure motor resistance and replace faulty motor. If drum drive belt has broken or is excessively worn, replace it.</p> <p>NOTE: Drum motor resistances (see wiring diagram):</p> <ul style="list-style-type: none"> ▪ 19 – 25 Ω (between points X2.2-X2.3 for WTL 54) ▪ 18 – 23 Ω (between points X2.2-X2.4 for WTL 54) ▪ 25 – 29 Ω (between points X2.2-X2.3 for WTA 35) ▪ 25 – 30 Ω (between points X2.2-X2.4 for WTA 35)
<p>Anti-Crease/End light flashes</p>	<p><input type="checkbox"/> Drying time too long</p>	<p><input type="checkbox"/> Control module failed.</p>	<p><input type="checkbox"/> Check voltage at and wiring to module. Turn off dryer, and replace faulty module.</p>

WARNING! Unplug dryer before starting any repairs.

WTA 35 & WTL 54 Service Tips -- Troubleshooting (3)

<i>Fault code</i>	<i>Problem</i>	<i>Possible Cause</i>	<i>Solution</i>
Anti-Crease/End light flashes (continued)		<ul style="list-style-type: none"> <input type="checkbox"/> Moisture sensor(s) failed. <input type="checkbox"/> Water level switch failed (WTL 54 only). <input type="checkbox"/> Hi-Limit ("overheat") thermostat tripped and failed to reset. <input type="checkbox"/> Supply voltage too low. 	<ul style="list-style-type: none"> <input type="checkbox"/> Run moisture sensor conductance test. Check voltage at and wiring to sensors. Turn off dryer and replace faulty sensor(s). <input type="checkbox"/> Check voltage at and wiring to Hi-Limit. Turn off dryer, measure Hi-Limit resistance and replace faulty Hi-Limit. <input type="checkbox"/> Reset Hi-Limit 1st. If still no heat, check voltage at and wiring to Hi-Limit. Turn off dryer, measure Hi-Limit resistance and replace faulty Hi-Limit. <p>NOTE: Hi-Limit trips @ 248°F (WTL 54) or 212°F (WTA 35).</p> <ul style="list-style-type: none"> <input type="checkbox"/> Have customer upgrade power system to provide consistent voltage to dryer during heating (need min. 198V).
E1	<ul style="list-style-type: none"> <input type="checkbox"/> Pump failed (WTL 5400 condensation dryer only) 	<ul style="list-style-type: none"> <input type="checkbox"/> Pump failed. 	<ul style="list-style-type: none"> <input type="checkbox"/> Check voltage at and wiring to pump. Turn off dryer, measure pump resistance (110 – 136 Ω) and replace faulty pump.
---	<ul style="list-style-type: none"> <input type="checkbox"/> Dryer won't run or indicator lights won't come on (no power to dryer) 	<ul style="list-style-type: none"> <input type="checkbox"/> Dryer not turned on. <input type="checkbox"/> No power to dryer. <input type="checkbox"/> Dryer fuse has blown. 	<ul style="list-style-type: none"> <input type="checkbox"/> Turn "on/off" switch on. <input type="checkbox"/> Check customer circuit breaker, fuse box or power connections. <input type="checkbox"/> Unscrew holder cap & replace fuse (15A, type SC-15).

WARNING! Unplug dryer before starting any repairs.

WTA 35 & WTL 54 Service Tips -- Dryer Operation (1): Moisture Sensing

The control module continually measures the conductivity of wet clothing (by measuring the voltage between the two sensors).

When the voltage matches the one required by the customer dryness setting, the dryer stops.

Sliding contacts (brushes) contact the inner and outer drums to give the voltage readings.

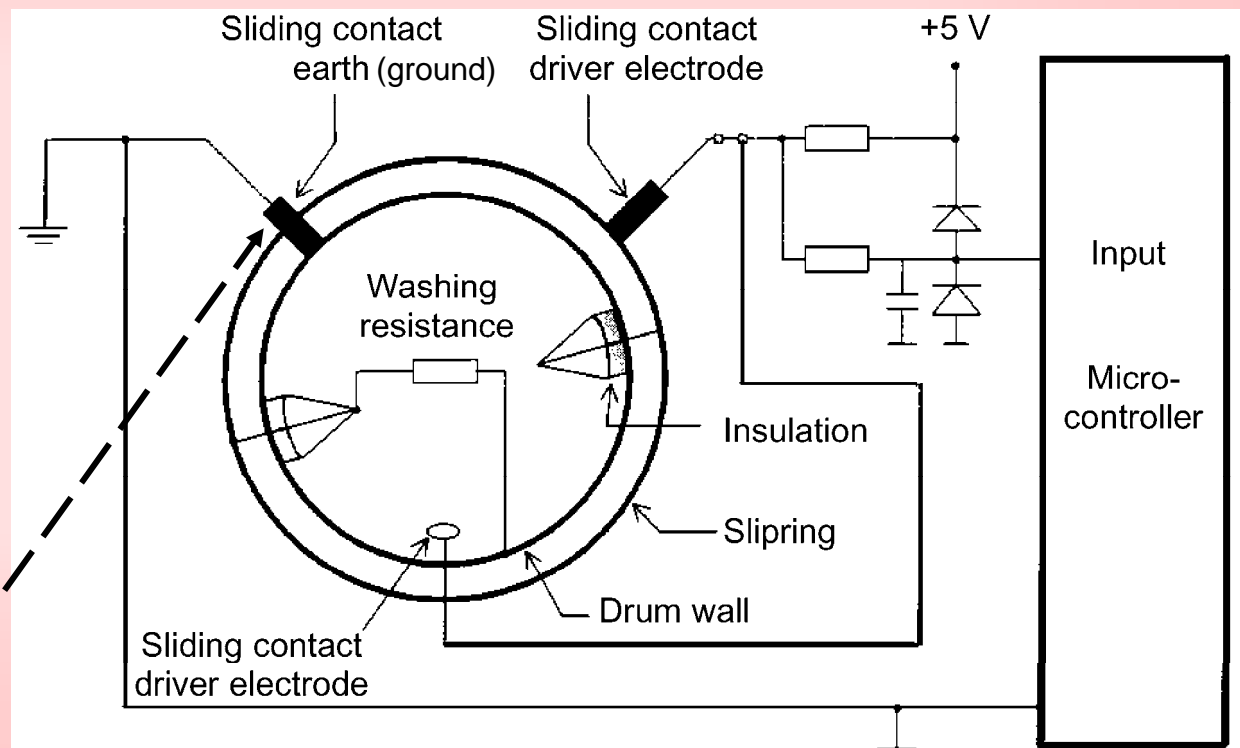
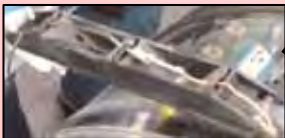

WTA 35 & WTL 54 Service Tips -- Dryer Operation (2): NTC Locations

Two NTC sensors measure the air temperature to prevent overheating.

- **NTC R2** -- Measures the air temperature in front of the heater.
- **NTC R3** -- Measures the air temperature at the dryer door.

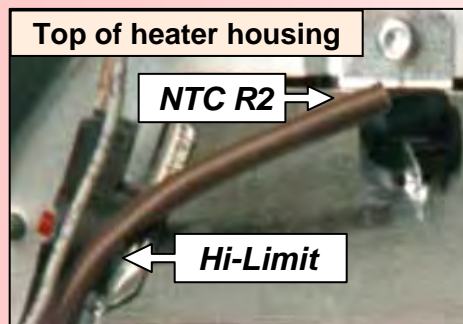
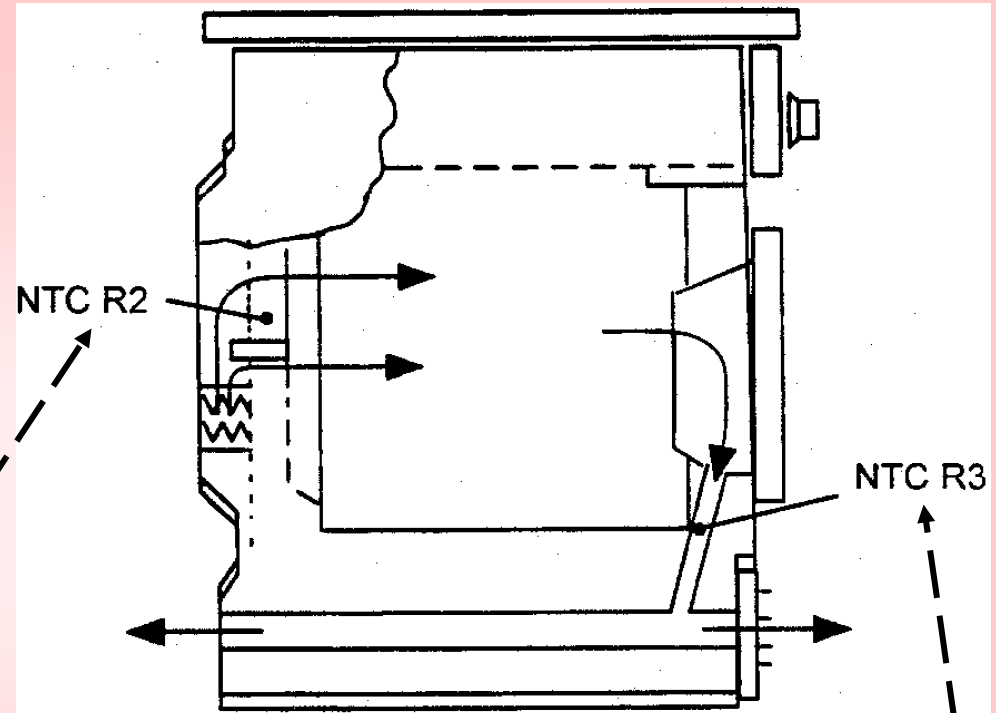

HINT: Keeping lint filter & vent hoses clean of lint will keep NTC's from tripping unnecessarily.

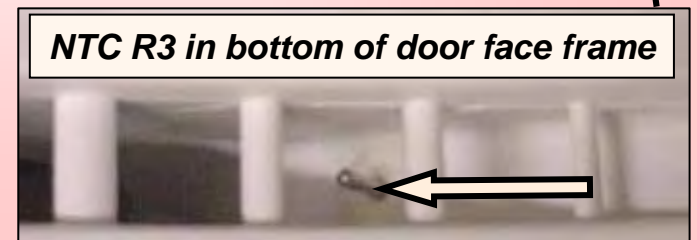

WTA 35 & WTL 54 Service Tips -- Dryer Operation (3): Preventing Overheating

The control module continually measures drying temperatures and turns off heaters as needed to lower temperatures to proper levels.

The control module drops the heat setting down one level whenever overheating occurs and whenever the drum rotates counterclockwise.

- From **3** (heater **E2** + **E3**) to **2** (heater **E3** only)
- From **2** (heater **E3** only) to **0** (off - no heat).

NOTE: Heaters cycle on and off as needed to keep temperatures at appropriate levels.

