



Fast Track Troubleshooting

Models

RB195AC/XAA**
RB197AC/XAA**
RB215AC/XAA**
RB217AC/XAA**

IMPORTANT SAFETY NOTICE – “For Technicians Only” This service data sheet is intended for use by persons having electrical, electronic, and mechanical experience and knowledge at a level generally considered acceptable in the appliance repair trade. Any attempt to repair a major appliance may result in personal injury and property damage. The manufacturer or seller cannot be responsible, nor assume any liability for injury or damage of any kind arising from the use of this data sheet.

Publication # **tsRB195AC** Revision Date 03/30/2011

NOTICE: 05/2010

Parts Change: Refer to bulletin. Refrigerator door and freezer drawer have been changed

NOTICE: Parts Bulletin

Handle change 2-2011

Self Diagnosis: Press the Pwr Freeze—Pwr Cool buttons simultaneously for 8-12 seconds (No sound when both buttons are pressed at the same time) until the display quits blinking. Release the buttons and read Fault Codes. This will also cancel the Fault Mode created by self-diagnosis at power up.

Forced Mode: Press the Pwr Freeze—Fridge buttons simultaneously for 8-12 seconds (No sound when both buttons are pressed at the same time) until the display beeps and goes blank.



Wait 5 seconds between button pushes

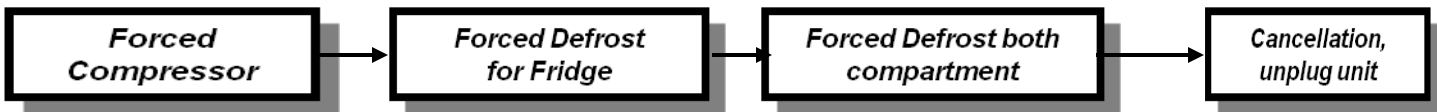

Press the Freezer button one time at the Test Mode to Force Compressor Run. Measure fan and compressor voltage at main PCB.

Press the Freezer button a second time to Force Fridge Defrost. Measure defrost voltage at main PCB.

Press Freezer button a third time to Force Defrost for Fridge & Freezer, measure defrost voltages at main PCB

Refrigerant Charge R134a 5.64 oz.

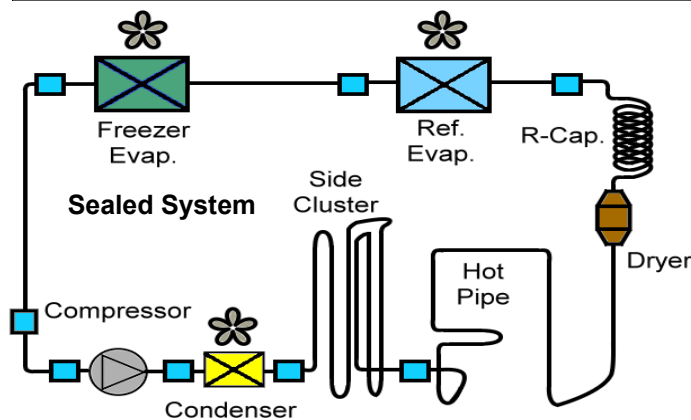

Sales Mode, No Compressor Operation

Press Power Freeze & Freezer temp buttons simultaneously for 3 sec (you will hear a “Ding Dong”) to remove or put into Sales Mode. When in the Sales Mode the Display will show "OF" "OF" Removing power will not cancel this mode.

Component Value Chart

Component	Resistance	Wattage	Voltage
Fridge Defrost Heater	120Ω	120	120vac
Freezer Defrost Heater	60Ω	240	120vac
Fill Tube	1108Ω	13	120vac
Sensors	2.5kΩ-89kΩ	N/A	1~4.5vdc
Fans	N/A	N/A	7~12vdc

SUPPORT INFORMATION

Training — Plus One <http://my.plus1solutions.net/clientPortals/samsung/>

Help — GSPN <http://service.samsungportal.com/>

Samsung Product Support TV <http://support-us.samsung.com/spstv/howto.jsp>

Customer information videos and chat programs. Programs for Fridges, Laundry, Ranges & D/W

DC FAN MOTORS

Brushless DC Fan motors are used to save energy. The fans operate at two speeds, High - when the ambient temperature is high and Low - when the temperature is low. Generally, it is operated in the High mode during a day time and in the Low mode at night. This circuit design is to protect the Main PCB from a failed fan motor.



Fan speed information is read by the Main PCB. If the fan speed exceeds 600 RPM or the speed is too slow or stopped, the fan drive circuit is disabled. After 10 seconds, the circuit tries again with 3 seconds of DC voltage. If the fan continues this activity for 5 cycles, 10 seconds off 3 seconds on, the fan drive circuit is disabled for 10 minutes.

TO TEST THE FAN CIRCUIT VOLTAGE.

Power off and back on to check the DC voltage to the motor, wait from 10 to 60 seconds for the fan voltage to kick in, and then check fan voltage, the average reading is 9 VDC. If you get 3 seconds of voltage every 10 seconds for the 5 fan power up cycles, then the Main PCB is good.

NOTE: You may need to put unit in FORCED FREEZE mode to activate the fans/compressor.

If the fan blade is blocked by ice, disconnect the power cord, then defrost and check the motor again.

If the evaporator is ice blocked and thus blocking the air flow, the fan will over RPM and is stopped. Remove ice and check the motor again. If everything is clear around the fan blade, then the motor would be at fault. Continuous fan errors will be displayed on the front panel display. PLEASE NOTE: The door switches control the evaporator fan motors. Have them closed to test the motors. Delay time 10 – 60 seconds.

An intermittent evaporator fan door switch could cause an intermittent no cool condition.

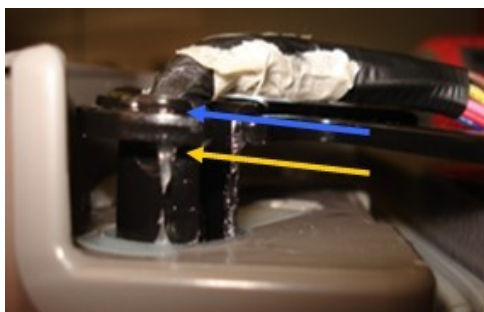

The Refrigerator Reed Switch and Magnet must be aligned for proper cooling operation.

The Top arrow shows the hinge improperly aligned, the Lower arrow shows the correct position of the hinge

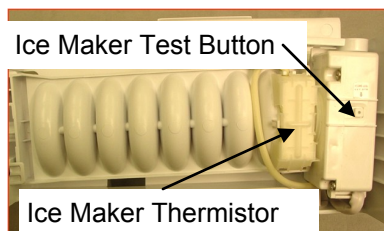
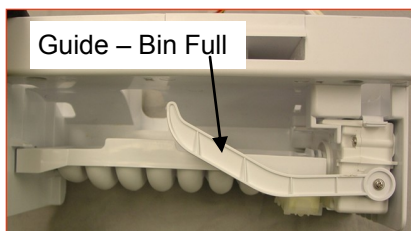

FLEX TRAY Ice Makers

When the initial power is applied, the ice tray will stand by for 2 hours. After the 2-hour standby time, the Ice Maker Sensor will check the temperature, when it is lower than 1.5°F for more than 5 minutes, it will do a harvest, with or without ice in the tray, then fill with water. 58 minutes after water is supplied to the Ice Tray, the Ice Maker Sensor temperature will be checked. When the Ice Maker Sensor maintains lower than 1.5°F for 5 minutes, it completes the harvest (if the ice bin is not sensed as full).

Thermistor senses temperature to determine water fill on newer units

Filling the tray

After the water fill is completed, the ice maker sensor will evaluate the water volume one and a half minutes later. When it detects no or low water level, it will add more water. First supply time will be 1.5 sec, next one will be 1 sec and the last will be 2 sec.

Shattered Ice – Flex Tray

When all ice shatters, it's because of a bad tray or ice cube temp that is too cold (lower than -5 degrees). In some areas, there are water issues that can also cause shattered cubes. The temp in the freezer should not have any effect on this issue, as long as it's below 1.5 degrees F, as a properly installed sensor will not read the freezer temp, only the water/ice temp.

Check the Ice tray for defects in the plastic. Ice that is too cold will shatter during harvest. This can be from the (1) sensor not reading the correct temp (2) or the sensor not mounted correctly (3). By programming the icemaker offset value to a lower number (4), the board not understanding the reading.

To check the sensor, you must check the tray temp (not air temp) and compare it to the sensor reading. The sensor should read 3.7 volts at the main board connector when the cube temperature is 1 degree. After the fill, the sensor will read water temp 1.5 to 2.2 volts.

To clear offsets, put unit into Diagnostics mode.

Please note, some shattering is normal for a flex tray icemaker.

**Condenser Fan
Delay function**

Ranges of ambient temp.	Operation
Above 66 °F	Condenser-Fan is ON as soon as the compressor is on.
61 °F ~ 65 °F	Condenser-Fan is ON with 5 minutes delay from the compressor on.
Below 60 °F	Condenser-Fan is OFF regardless of the compressor operation

Sensors

Defrost – The sensor voltage tells the Main PCB to turn off the Defrost Heater At 50° in Freezer, 63° in Fridge

Compartment Temp – The sensor controls fan/compressor on/off to maintain temp

Ice Production – harvests when the I/M sensor reads 1.5 degrees for 5 minutes, Flex Tray Only.
If the door is opened during that 5 minutes harvest is delayed.

Ambient Sensor

Fan Speeds – Below 60 degrees condenser fan is off
Defrost Timing – The warmer the room the more often the defrost

How to Check Sensor Resistances Accurately

Make ice slurry. To do this, fill a cup with ice (preferably crushed), then add water and a teaspoon of salt to make a slush. Mix thoroughly and allow to sit for 2 to 3 minutes. This will give you a 32°F reference. Now, lower the sensor into the mixture and leave for about 1 minute, then check the resistance. It should be very close to 13,300 ohms. Before reinstalling the sensor, be sure to rinse it with fresh water and dry it.

Temperature/Resistance/Voltage Chart for Samsung Refrigerators Sensors

















Temp.	(Ω)	Volts	Temp.	(Ω)	Volts	Temp.	(Ω)	Volts	Temp.	(Ω)	Volts
-29.2°F	64227	4.326	1.4°F	28021	3.685	32.0°F	13290	2.853	62.6°F	6771	2.019
-27.4°F	61012	4.296	3.2°F	26760	3.64	33.8°F	12749	2.802	64.4°F	6521	1.974
-25.6°F	57977	4.264	5.0°F	25562	3.594	35.6 °F	12233	2.751	66.2°F	6281	1.929
-23.8°F	55112	4.232	6.8°F	24425	3.548	37.4 °F	11741	2.7	68.0°F	6052	1.885
-22.0°F	52406	4.199	8.6°F	23345	3.501	39.2 °F	11271	2.649	69.8°F	5832	1.842
-20.2°F	49848	4.165	10.4°F	22320	3.453	41.0°F	10823	2.599	71.6°F	5621	1.799
-18.4°F	47431	4.129	12.2°F	21345	3.405	42.8°F	10395	2.548	75.2°F	5225	1.716
-16.6°F	45146	4.093	14.0°F	20418	3.356	44.6°F	9986	2.498	77.0°F	5000	1.675
-14.8°F	42984	4.056	15.8°F	19537	3.307	46.4°F	9596	2.449	78.8°F	4861	1.636
-13.0°F	40938	4.018	17.6°F	18698	3.258	48.2°F	9223	2.399	80.6°F	4690	1.596
-11.2°F	39002	3.98	19.4°F	17901	3.208	50.0°F	8867	2.35	86.0°F	4218	1.483
-9.4°F	37169	3.94	21.2°F	17142	3.158	51.8°F	8526	2.301	87.8°F	4072	1.447
-7.6°F	35433	3.899	23.0°F	16419	3.107	53.6°F	8200	2.253	89.6°F	3933	1.412
-5.8°F	33788	3.858	24.8°F	15731	3.057	55.4°F	7888	2.205	91.4°F	3799	1.377
-4.0°F	32230	3.816	26.6°F	15076	3.006	57.2°F	7590	2.158	95.0°F	3547	1.309
-2.2°F	30752	3.773	28.4°F	14452	2.955	59.0°F	7305	2.111	96.8°F	3428	1.277
-0.4°F	29350	3.729	30.2°F	13857	2.904	60.8°F	7032	2.064	100.4°F	3204	1.213

Defrost and Diagnostic Code Information

This model series uses a Defrost Sheath Heater in the Fridge compartment and the Defrost Heater in the Freezer is part of the Evaporator Coil.

NOTE: Evaporator Covers May Break If Removed While Frozen To Coil. They must be replaced if there is any damage, as this will cause "ice" to form at top or bottom of the evaporator coil or in the drains.

Defrost Cycle Timing		
First Defrost Cycle, Both Fridge & Freezer	Defrost Cycle Fridge only	Defrost Cycle Fridge & Freezer
6 hrs, Pause Time 12 minutes	6~11 hrs (varies according to conditions)	12~23 hrs (varies according to conditions)

Samsung 'Refrigerator' Diagnostic Code Quick Guide			
Error Items	LED	TROUBLE	TESTING
I/M-SENSOR (R on Twin I/M units)	<i>Fridge</i> 	Ice Maker Sensor Error- open or short-circuit, connector failure. Cause is also a temperature reading > 122° or < -58 ° F	The voltage at MAIN PCB Sensor between 4.5V~1.0V
R-SENSOR	<i>Fridge</i> 	Refrigerator Room Sensor Error- open or short-circuit, connector failure. Cause is also a temperature reading > 122° or < -58 ° F.	The voltage at MAIN PCB Sensor between 4.5V~1.0V
DEFROST SENSOR OF R ROOM	<i>Fridge</i> 	Ref. Defrost Sensor Error- open or short-circuit, connector failure. Cause is also a temperature reading > 122° or < -58 ° F	The voltage at MAIN PCB Sensor between 4.5V~1.0V
R-FAN ERROR	<i>Fridge</i> 	This error indicates the Refrigerator Evap Fan is not spinning at the correct RPM or the fan feedback line is open.	Fan voltage at MAIN PCB shall be between 7V~12V
I/M FUNCTION ERROR(R on Twin I/M)	<i>Fridge</i> 	This error indicates the Ice tray has not returned to level after an ice harvest. The error is displayed after three failed attempts.	Replace I/M
R-DEFROSTING ERROR	<i>Fridge</i> 	Refrigerator Room defrost heater- open or short-circuit, connector failure, or defective temperature fuse/bi-metal. Defrost on over 80 minutes	Disconnect defrost connector from PCB, check resistance
EXT-SENSOR	<i>Freezer</i> 	Ambient Temp. Sensor Error- open or short-circuit, connector failure. Cause is also a temperature reading > 122° or < -58 ° F	The voltage at MAIN PCB Sensor between 4.5V~1.0V
F-SENSOR	<i>Freezer</i> 	Freezer Compartment Sensor Error- open or short-circuit, connector failure. Cause is also a temperature reading > 122° or < -58 ° F	The voltage at MAIN PCB Sensor between 4.5V~1.0V
F-DEF-SENSOR	<i>Freezer</i> 	Freezer Room Defrost Sensor Error- open or short-circuit, connector failure. Cause is also a temperature reading > 122° or < -58 ° F	The voltage at MAIN PCB Sensor between 4.5V~1.0V
F-FAN ERROR	<i>Freezer</i> 	This error indicates the Freezer Evap. Fan is not spinning at the correct RPM or the fan feedback line is open.	Fan voltage at MAIN PCB shall be between 7V~12V
C-FAN ERROR	<i>Freezer</i> 	This error indicates the Condenser Fan is not spinning at the correct RPM or the fan feedback line is open.	Fan voltage at MAIN PCB shall be between 7V~12V
F-DEFROSTING ERROR	<i>Freezer</i> 	Freezer defrosting heater- open or short-circuit, connector failure, or defective temperature fuse/bi-metal. Defrost on for over 80 minutes	Disconnect defrost connector from PCB, check resistance
ICE PIPE HEATER ERROR	<i>Freezer</i> 	Error is displayed when the ice maker fill pipe heater is open or shorted.	Replace Fill Tube Ass'y
Uart ERROR COMMUNICATION	<i>Freezer</i> 	This error is not applicable, if the error is detected during diagnostic testing please ignore it.	No Repair Necessary
L↔M ERROR COMMUNICATION	<i>Freezer</i> 	Communication error within the Main PCB	Replace main PCB
P↔M ERROR COMMUNICATION	<i>Freezer</i> 	Communication between the Main PCB and Keypad	Check wiring in door & cabinet, Panel PCB, Main PCB

CN= Connector # for measuring voltages; () means go to connector #, pin # shown in () for voltage common.

CN30 Sensors & Switches Component Name

4-(CN76-1) F Def Sensor (Org-Gry) 2.3~4.2vdc

Voltage on operating component

Pin #s & wire colors on each connector to measure voltages

Key To Read PCB Layout

RB195AC, RB197AC, RB215AC, RB217AC

Main PCB Layout

CN71 120vac

- 3-(CN72-9) R Lamp (Blu-Red)
- 5-(CN72-9) F Lamp (Pnk-Red)
- 9-(CN72-9) Ice Water Valve (Prp-Red)

CN72 120vac

- 1-9 Compressor (S/Blu-Red)
- 5-3 R Heater (fill tube htr) (Wht-Org)
- 7-3 F Heater (Brn-Org)

CN10 120vac 3 - L1 (Red)

CN50 Display Panel

CN30

- 1-7 F Door SW (Blk-Gry)
- 2-7 R Door Sw (Brn-Gry)
- 3-8 R Room Sensor (Red-Gry) 2.4 ~ 2.8 vdc
- 4-8 R Def Sensor (Org-Gry) 2 ~ 4.2 vdc
- 5-8 F Room Sensor (Yel-Gry) 3.5 ~ 4.2 vdc
- 6-8 F Def Sensor (Pnk-Gry) 2.3 ~ 4.2 vdc

CN31

- 1- 3 Ambient Sensor (Wht-Wht) 1.2 ~ 2 vdc

CN90 Ice Maker

- 7-8 I/M Motor (Wht-Red) 12 vdc
- 5-6 I/M Senor (Wht-Wht) 2.1 ~3.7 vdc
- 5-8 Test Sw (Gry-S/Blu)

CN756F, R, C Fans

- 1 C Fan FG(Blu) 7.5 ~ 9.9 vdc
- 2 F Fan FG(Pnk) 9.9 ~ 11.8 vdc
- 3 R Fan FG(Yel) 8.2 ~ 9.9 vdc
- 4-7 C Fan (Org-Gry)
- 5-7 F Fan (Red-Gry)
- 6-7 R Fan (Brn-Gry)

