



Fast Track Troubleshooting

Models:
DMT800RHS/XAA
DMT800RHB/XAA
DMT800RHW/XAA

IMPORTANT SAFETY NOTICE – “For Technicians Only” This service data sheet is intended for use by persons having electrical, electronic, and mechanical experience and knowledge at a level generally considered acceptable in the appliance repair trade. Any attempt to repair a major appliance may result in personal injury and property damage. The manufacturer or seller cannot be responsible, nor assume any liability for injury or damage of any kind arising from the use of this data sheet.

Publication # tsDMT800RF Revision Date 03/21/2011

Which Detergent Ingredients Give Best Dishwasher Performance

Detergent with a separate rinse additive in the dispenser gives better drying performance.
 For tough baked on soils an Enzyme detergent is better at hydration of the food soils.
 For staining such as tomato, coffee and tea, a detergent with Chlorine bleach will work on the stains much better than an Enzyme based detergent. Now that phosphate content in dishwasher detergent has plummeted to 0.5 percent from as high as 8.7 percent, conditioned (soft) water is even more critical. The reduction of phosphates may cause spots and film on dishes that can form when the minerals and food bits combine during the wash.
It is important to test water hardness for washability complaints.

SEE BULLETIN

The Dishwasher power button will not operate unless the circuit breaker is cycled off and on. This applies to models produced between June 2010 and December 2010, serial number range **Z6**~**ZC**).

SUPPORT INFORMATION

Training — Plus One
<http://my.plus1solutions.net/clientPortals/samsung/>
 Help — GSPN <http://service.samsungportal.com/>
 Samsung Product Support TV
<http://support-us.samsung.com/spstv/howto.jsp>
 Customer information videos and chat programs
 Programs for Fridges, Laundry, Ranges & D/W

Dishwasher Cycle Chart — Air diffusion condensing Dry System

Cycle	Pre-wash 1	Pre-wash 2	Main wash	Rinse 1	Rinse 2	Rinse 3	Last Rinse [Sanitize]	Dry (min.)	Water [gal(ℓ)]	Time (min.)
Normal	●	Flex	120 ~ 138 °F	Flex	●	x	136 °F [162 °F]	30	3.6~6.7 (13.6~25.2)	110~132
Heavy	●	●	140 °F	●	●	●	158 °F [162 °F]	40	8.1 (30.6)	152
Delicate	●	x	122 °F	●	●	x	140 °F	30	4.7 (17.7)	107
Pot & Pans	●	131° F	149 °F	●	●	●	158 °F [162 °F]	40	8.1 (30.6)	157
Quick +	●	x	140 °F	x	●	x	140 °F [162 °F]	15 (+15)	4.7 (17.7)	59
Smart Auto	●	Flex	122 ~138 °F	Flex	●	x	136 °F [162 °F]	30	4.7~6.7 (17.7~25.2)	100~149

- The numbers in parentheses in the Last Rinse column represent the temperature when you select Sanitize.
- When you select the Smart Auto or Normal cycle, you can eliminate the Flex (flexible) steps depending on the soil level
- The wash time varies with the steps or options you add, and on the pressure and temperature of the supplied water.
- When you select Half Load or Storm Wash, the cycle sequence remains the same. (DMT800)
- If “Rinse Refill” lamp lights during a cycle, the dishwasher adds 30 more minutes to the Drying cycle automatically after the Clean light illuminates.

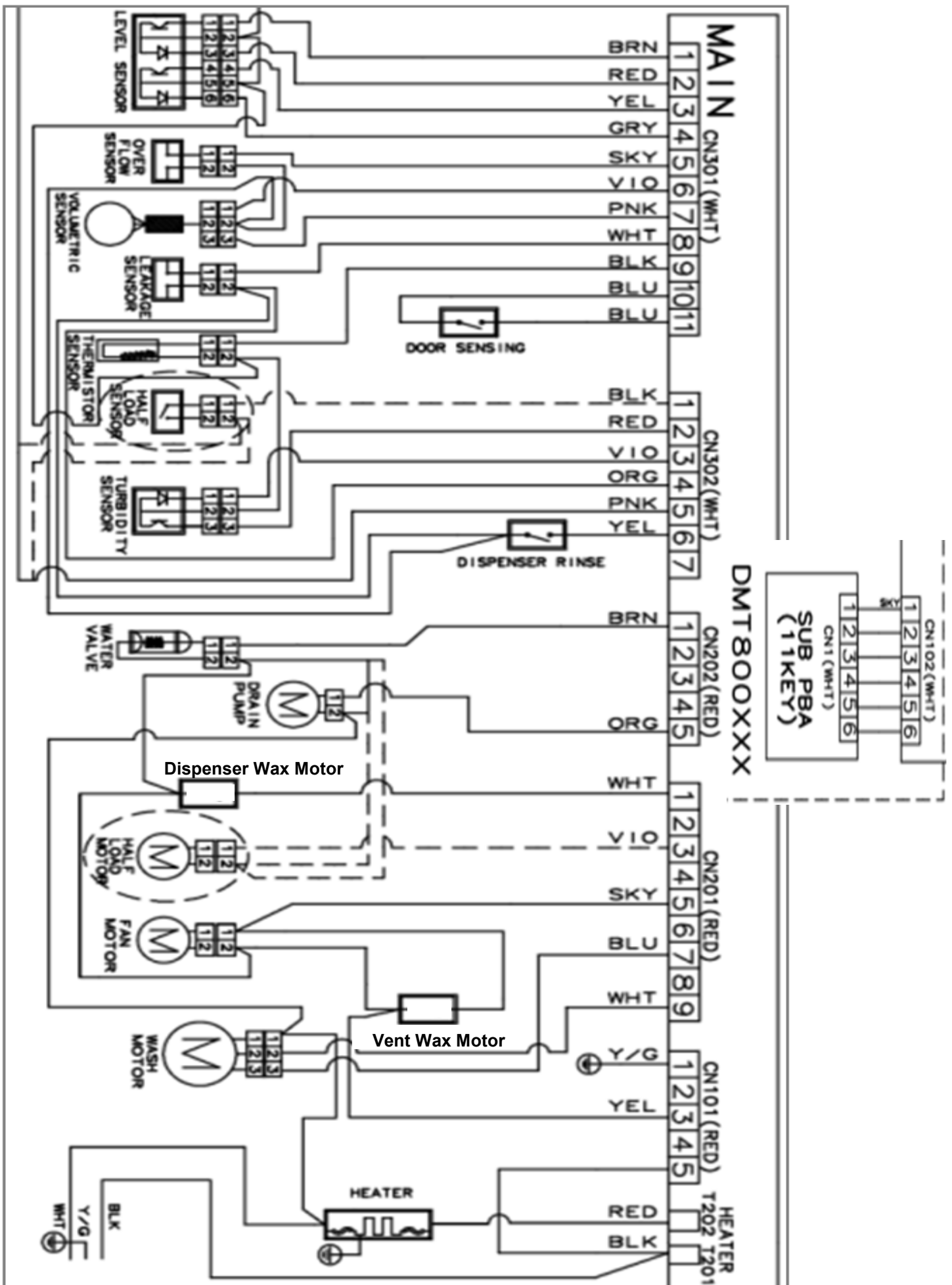

Main PCB

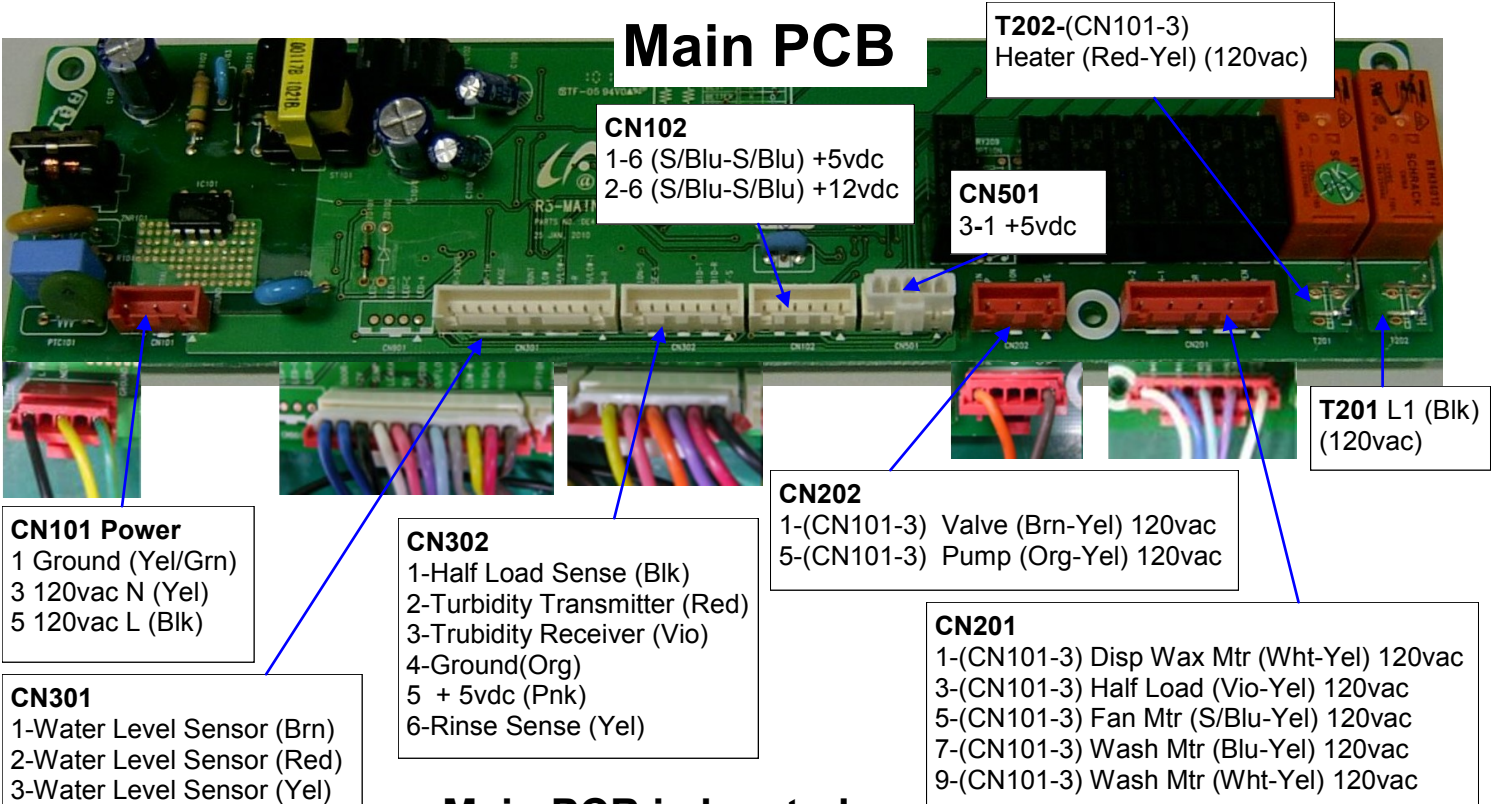

Main PCB is located behind bottom access panel

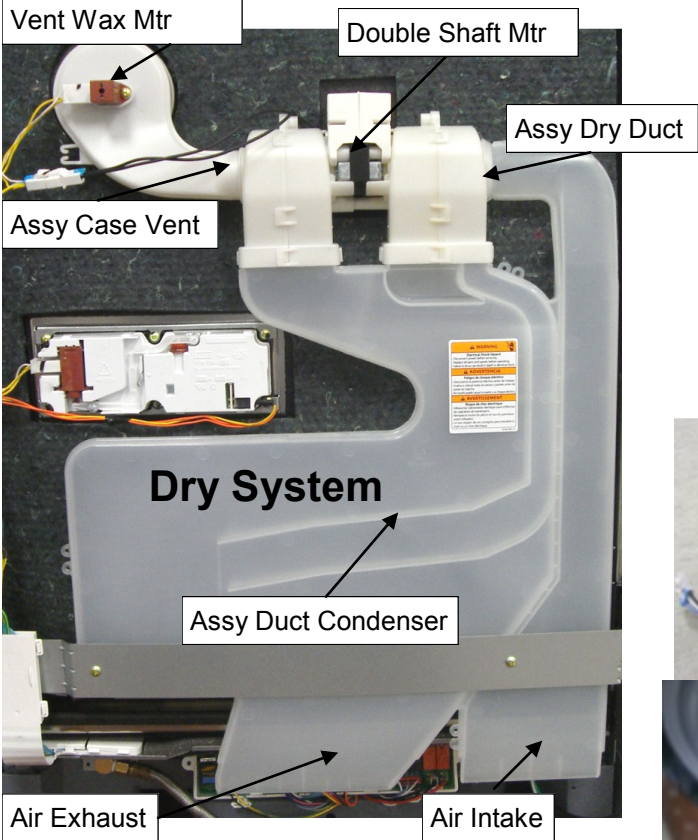

Single rear leg is adjustable from front. Retract to remove D/W

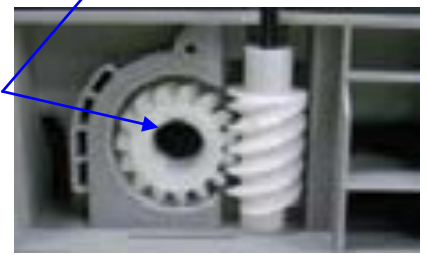

Sump & Heater



Storm wash Nozzle



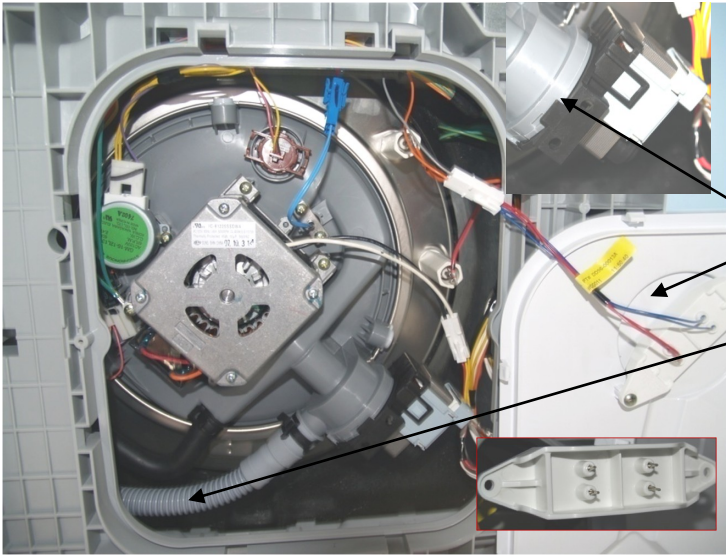

Leaking Code

Moisture creates resistance between the pins. **ALWAYS** clean the area below the pins after troubleshooting.

Check Pump Ass'y for proper twist lock.

Condensation may form on the tray from uninsulated outside walls or large hole in the floor to a cold basement.

Check Drain Hose for cut or small hole.

Check all components mounted to the sump for any leakage.

Detergent Door Not Opening

1. Never overfill the dispenser compartment with powder or liquid, only go below or up to fill line.
2. If there is residue around the dispenser door area. Previously undispensed, partially dispensed, or door stuck close issue) clean it with mild soap & water. The residue can foul the mating latch.
3. If the customer uses "tablets" or some self contained type of soap tab, make sure it is fully seated and the door does not 'sandwich' it shut.
4. Make sure that in the rack nearest to the dispenser door when the door is shut, is not obstructing the opening of the dispenser with some protruding utensil.



Vent seal actuated by wax motor



Testing The Detergent Door and Dispenser

1. Disconnect wires from disp. & close detergent door.
2. Connect Fused cheater cord and apply 120vac
3. In approximately 40 seconds the wax motor will open the door.
4. Remove power, allow wax motor to return.
5. Restore power to wax motor, in approximately 40 seconds the rinse aid will be activated. Remove power.
6. Close detergent door to repeat test



Upper Nozzle : Remove it by rotating the holder. (counterclockwise)



Middle Nozzle : Remove it by rotating the holder. (counterclockwise)



Lower Nozzle : Pull it out carefully from the Assy sump.

Error Codes - DMT800 series

Code symbol	Meaning	Occurring condition	Expected condition
	Temp sensor Error	When 0.2V or below, or 4.5V or above is maintained for over 3 seconds	Thermistor terminal is not connected Possible defect : Thermistor , Main PBA
HE	Heater Error	When the temperature change is 4°C or less within the first 10 minutes after the heating starts	Heater terminal is not connected Possible defect : Main Wire-Harness, Heater, Main PBA
1E	High temp Heating error.	When the temp of the Thermistor is 80°C or above for more than 3 seconds during operation.	Water temp is 80°C or above Possible defect : Thermistor , Main PBA
9E	Low-level water error	1.When high level sensor is not detected after water supply was done, drain & refill the water. After then, if high level sensor is not detected again, this error is occurred. 2.When low level sensor is detected over 5 seconds during wash operation, this error is occurred.	Water Level Sensor terminal is not connected Possible defect : Assy case sensor, Water Level Sensor , Main PBA
PE	Half load function error	When micro s/w is not detected for over 30 seconds after the Distributor motor starts	Distributor motor defect Micro SW terminal is not connected Main PBA defect
4E	Water supply error	1. When the pulse of 100 or less is detected even 73 seconds after the water supply 2. When flow meter pulse is 5 or less for 13 seconds after the water supply starts 3. When the water supply is not finished until 6 minutes after the water supply starts	Alien particles within water supply valve Water supply valve terminal not connected Possible defect : Main PBA, Water supply valve , Flow Meter
3E	High temp Water supply error	When 80°C or above is detected during water supply	Water supply temperature is 80°C or above Possible defect : Thermistor, Main PBA
5E	Drain error	When OFF status of Low Level S/W is not detected within 3 minutes during the drain.	Alien particles are clogging in drain hose Drain pump terminal is not connected Possible defect : Drain pump, Water Level Sensor , Main PBA
oE	Over-level water error	When overflow detection AD data is 3.5V or below for 3 seconds (When leakage sensor detects 3.5V or below for 1 seconds during water supply)	Alien particles within water supply valve Case Sensor part breakdown Possible defect : Flow Meter, Main PBA, Water supply valve
LE	Leakage	When leakage sensor detects 3.5V or below for 1 seconds	Possible defect : Each hose connection , Sump and Tub assembly, Drain Pump assembly , Main PBA
bE	Button error	When the button is pressed continuously for over 10 seconds	Possible defect : Sub PBA in control panel, Main PBA
dE	Door open warning	When door is open in washing period.	Door is not close properly in test mode only. Possible defect : Door lock switch, Main PBA

SVC inspection Mode- DMT800 series

- Press the 'Heavy' + 'Delicate' + 'Power' buttons at the same time for two seconds to enter Service Inspection Mode.
 - All LEDs are displayed for the first two seconds and then Software-Ver. will be indicated.
 - You can change the mode by pressing the Normal button again. If press the Normal button in this mode, the mode will be changed to next mode.
 - If you want to activate a mode while operating the dishwasher, the door must be closed.
 - If 'LE', 'OE', 'tE' error occur, enter Service Inspection Mode after resolving it.
- Service Inspection Mode is described in the following table.

Mode	Display	Related Parts	Symptoms	Note
No.1	Ft	•Drain pump •Inlet Valve •Flow Meter •Water Level Sensor •Turbidity	Door open warning Water supply Error Low level water Error Turbidity Error	If Door is open, Door open warning (dE) will blink. If low level sensor is not detected, Drain is executed. Water supply will be executed when low level sensor is detected. If water is not fully supplied (sensing on flow-meter), the Water Supply Error (4E) will blink. When high level sensor is not detected after water supply was done, Low-level water error (9E) will blink. When Turbidity problem is occurred after water supply was done, Turbidity Error (AE) will blink. If all functions in this mode are completed, 'Ft' and '3.6~3.9' will blink.
No.2	Lc	•Circulation Motor	A nozzle does not inject water.	If Low Level sensor is detected before Circulation Motor is operating, 'LL' and 'Lc' will blink. When water is filled enough, Circulation Motor -2(190W) will be operated.
No.3	Ld	•Circulation Motor	A nozzle does not inject water.	If Low Level sensor is detected before Circulation Motor is operating, 'LL' and 'Ld' will blink. When water is filled enough, Circulation Motor- 1(150W) will be operated.
No.4	Hd	•Circulation Motor •Heater •Thermistor •Dispenser	Heater Error	If Low Level sensor is detected before Circulation Motor is operating, 'LL' and 'Hd' will blink. When water is filled enough, Circulation Motor 1(150W) and Heater will be operated. 'Temperature[°C]' and 'Hd' will blink. When the temperature meet 60°C or above, the heater is turned off. If Heater or Thermistor have problems, the Heater Error (HE) will blink. Dispenser will operate during 130 seconds only one time.
No.5	SH	•Half Load Motor	Half load function Error	If Low Level sensor is detected before Circulation Motor is operating, 'LL' and 'SH' will blink. When water is filled enough, Half Load Motor will be operated, and then Half load function will be operated.
No.6	SP	•Half Load Motor	Storm wash function Error	If Low Level sensor is detected before Circulation Motor is operating, 'LL' and 'SP' will blink. When water is filled enough, Half Load Motor will be operated, and then Storm wash function will be operated.
No.7	dF	•Dry Fan Mtr •Dispenser	The Dry Fan motor does not work.	Operate the Dry Fan Motor and check whether Rinse aid is filled or not. If there is not rinse aid in Dispenser, Rinse Refill lamp is ON.
No.8	L	•Inlet valve •Overflow	Over level water Error	Water is supplied until Over-level water error (oE) is blinked. If Over-level water error (oE) occurs, overflow sensor is OK.

SVC inspection Mode- DMT800 series

- Press the 'Heavy' + 'Delicate' + 'Power' buttons at the same time for two seconds to enter Service Inspection Mode.
 - All LEDs are displayed for the first two seconds and then Software-Ver. will be indicated.
 - You can change the mode by pressing the Normal button again. If press the Normal button in this mode, the mode will be changed to next mode.
 - If you want to activate a mode while operating the dishwasher, the door must be closed.
 - If 'LE', 'OE', 'tE' error occur, enter Service Inspection Mode after resolving it.
- Service Inspection Mode is described in the following table.

Mode	Display	Related Parts	Symptoms	Note
No.9	S	•Drain Pump •Water Level Sen-	Drain Error	Drain pump will drain until low level sensor is detected. If Low level sensor is not detected after 60 seconds, Drain Error (5E) will blink.
No.10	FL	•Half Load Motor	Half load function Error	Buzzer sound is generated when the Half Load Motor is initialized to full load location, and the 'FL' will blink.
No.11	Temp	•Inlet Valve •Circulation Motor •Dry Fan Motor •Drain Pump •Heater •Half Load Motor		Operate each operating part when the key is pressed. (See the below) When the 'Quick' Key is pressed Water supply is On('Quick' LED On) and pressed again it is Off ('Quick' LED Off) When 'Heavy' Key is pressed each time, it works the Circulation Motor-1 is On ('Heavy' LED On) -> Off ('Heavy' LED Off) -> Circulation Motor-2 is On ('Heavy' LED On) -> Off ('Heavy' LED Off) -> Dry Fan Motor is On ('Heavy' LED On) -> Off ('Heavy' LED Off), Drain Pump is On ('Heavy' LED On) -> Off ('Heavy' LED Off). When 'Delicate' Key is pressed, it works Heater On ('Delicate' LED On during 2 seconds) and Off automatically. When 'Half Load' Key is pressed Half Load Motor is On('Half Load' LED On) and pressed again it is Off('Half Load' LED Off). When a different key is pressed during individual operation of the operating part, present operating part is stopped and the applicable operation for the pressed key will start.

Thermistor			
Resistance (kΩ)	Temp. (°F)	Resistance (kΩ)	Temp. (°F)
125.78	41	26.065	104
98.323	50	21.385	113
77.454	59	17.599	122
61.465	68	14.579	131
49.12	77	12.14	140
39.517	86	10.159	149
31.996	95	8.542	158

Components		
Component	Voltage	Ω
Water Valve	120vac	1.2 KΩ
Drain Pump	120vac	22Ω
Heater	120vac	15Ω
Fan Mtr	120vac	76Ω
Disp Wax Mtr	120vac	2.3KΩ
Vent Wax Mtr	120vac	1.28kΩ
Half Load Mtr	120vac	3.9kΩ
Circulation Mtr	120vac	15Ω/21Ω