



TECHNICAL EDUCATION

2009 JENN-AIR INTEGRATED BUILT IN REFRIGERATORS



JB36NXFXLW00
JB36NXFXRW00

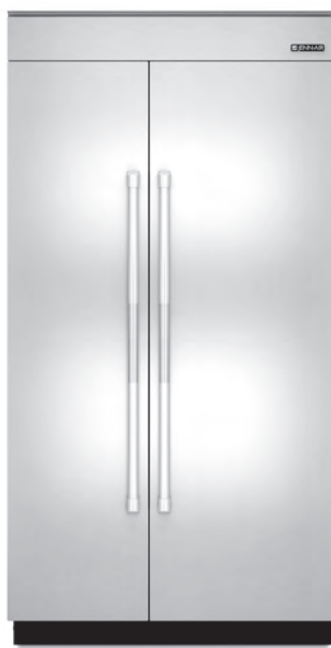

JS42NXFXDW00
JS48NXFXDW00



JF42NXFXDW00

JOB AID 8178776

FORWARD

This Job Aid (Part No.8178776), provides the In-Home Service Professional with information on the installation, operation, and service of this refrigerator. For specific information on the model being serviced, refer to the “Use and Care Guide,” or “Tech Sheet” provided with the refrigerator.

The Wiring Diagrams used in this Job Aid are typical and should be used for training purposes only. Always use the Wiring Diagram supplied with the product when servicing the refrigerator.

GOALS AND OBJECTIVES

The goal of this Job Aid is to provide information that will enable the In-Home Service Professional to properly diagnose malfunctions and repair Jenn-Air Integrated Built In Refrigerators.

The objectives of this Job Aid are to:

- Understand and follow proper safety precautions.
- Successfully troubleshoot and diagnose malfunctions.
- Successfully perform necessary repairs.
- Successfully return the refrigerator to its proper operational status.

WHIRLPOOL CORPORATION assumes no responsibility for any repairs made on our products by anyone other than authorized In-Home Service Professionals.

TABLE OF CONTENTS

	Page
GENERAL	1-1
Jenn-Air Model & Serial Number Designations	1-1
Model & Serial Number Label And Tech Sheet Locations	1-2
Bottom Mount Features	1-3
French Door Features	1-4
Side By Side Features	1-5
 INSTALLATION INFORMATION	 2-1
Installation Requirements Models	2-2
Installation Requirements	2-5
Installation Instructions	2-13
 PRODUCT OPERATION	 3-1
Theory Of Operation	3-1
 COMPONENT ACCESS	 4-1
Component Locations	4-1
Articulated Hinges	4-2
Top Door Hinge Adjustment	4-3
Refrigerator Door Switches and Lights	4-4
Ice Maker	4-5
Modular Ice Maker	4-6
Accessing Evaporator and Related Components	4-7
Accessing Defrost Heater	4-9
Accessing air damper	4-10
Back Panel	4-11
Thermistor Location	4-12
Removing A Refrigerator Light Socket Bottom Mount Models	4-13
Removing The User Interface Assembly Bottom Mount Models	4-14
Removing The Refrigerator Thermistor Bottom Mount Models	4-15
Removing The Refrigerator Thermistorbottom Mount Models	4-16
Removing A Refrigerator Temp-Controlled Motorized Air Door	4-17
Removing A Temp-Controlled Drawer Coverbottom Mount Models	4-18
Removing The Heated Flipper Mullion And An Actuator / Electrical Contact42" French Door	4-20
Accessing The Machine Compartment	4-22
Removing The Freezer Drawer Switch Bottom Mount Product	4-25
 COMPONENT TESTING	 5-1
Bottom Mount Refrigerators	5-1
Thermistor	5-2
Heated Flipper Mullion42" French Door	5-3
Motorized Air Door	5-3
Condenser Fan Motor	5-4
Evaporator Fan Motor	5-4
Door/Drawer Switch	5-5

TABLE OF CONTENTS (continued)

Fill Tube Heater	5-5
Defrost Heater & Bimetal	5-6
Water Valve	5-6
Adjusting The Freezer Door Bottom Mount Models	5-7
DIAGNOSTICS & TROUBLESHOOTING	6-1
Bottom Mount Models	6-1
Service Diagnostics Mode	6-2
Service Information	6-3
WIRING DIAGRAMS	7-1
Service And Wiring 42 And 48" SxS.	7-1
Service And Wiring 36" Bottom Mount	7-2
Service And Wiring 42" French Door	7-3
Example 36" Bottom Mount Refrigerator Wiring Diagram	7-4
Example 42" And 48" Side By Side Refrigerator Wiring Diagram	7-5
Example 42" French Door Refrigerator Wiring Diagram	7-6

JENN-AIR MODEL & SERIAL NUMBER DESIGNATIONS

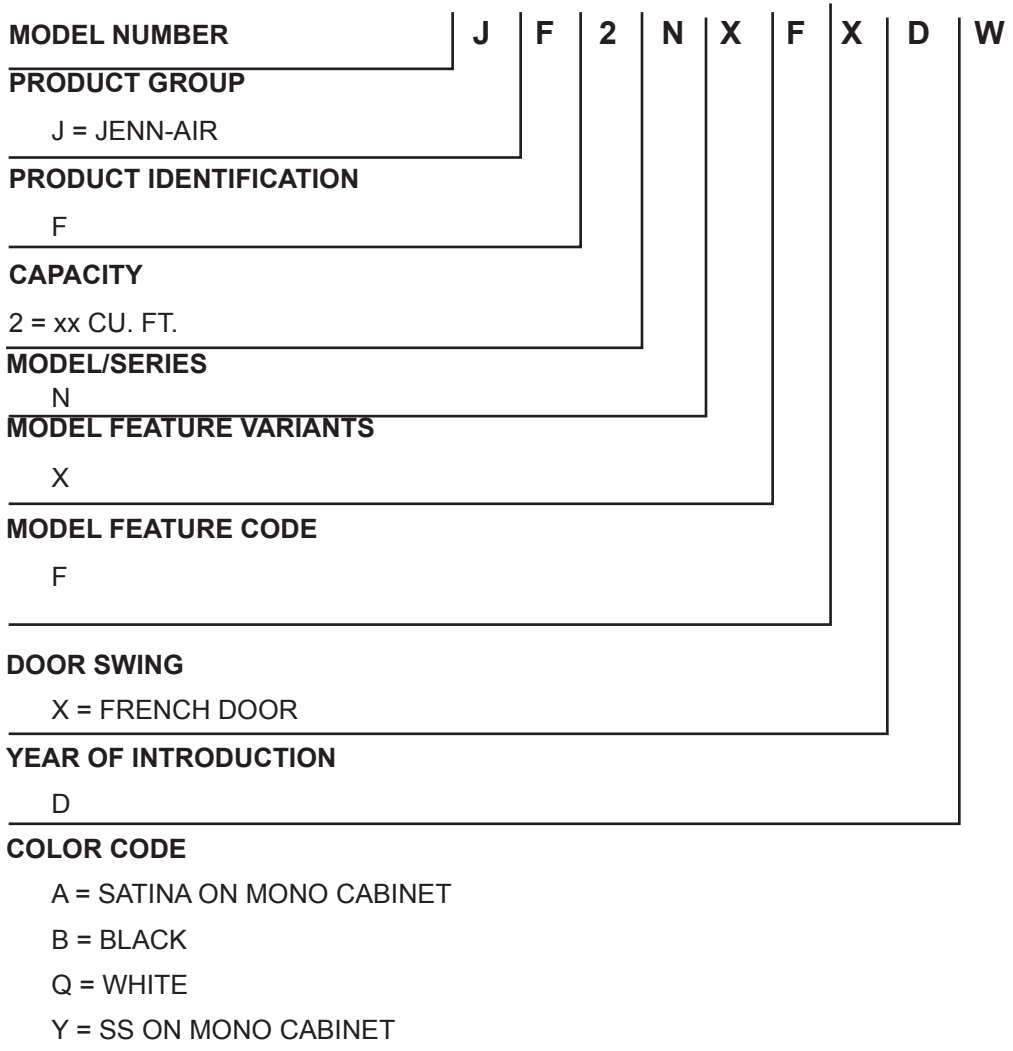

SERIAL NUMBER

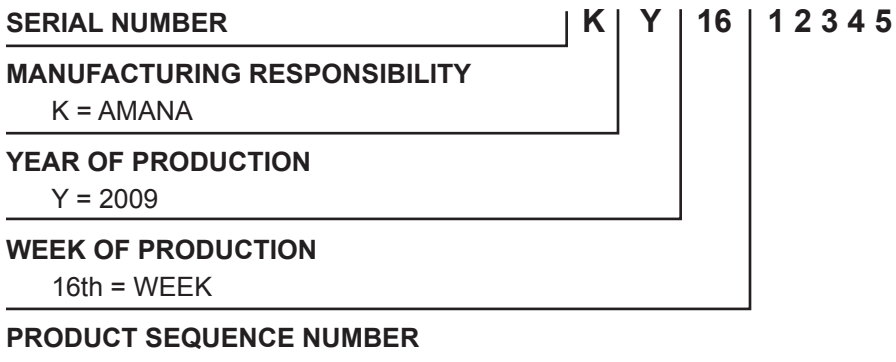

MODEL & SERIAL NUMBER LABEL AND TECH SHEET LOCATIONS

The Model/Serial Number label and Tech Sheet locations are shown below.

Model & Serial Number Label Location
(On Upper Right Side Of Refrigerator Liner)



Tech Sheet Location
(On Upper Right Side Of Machine
Compartment Cover)

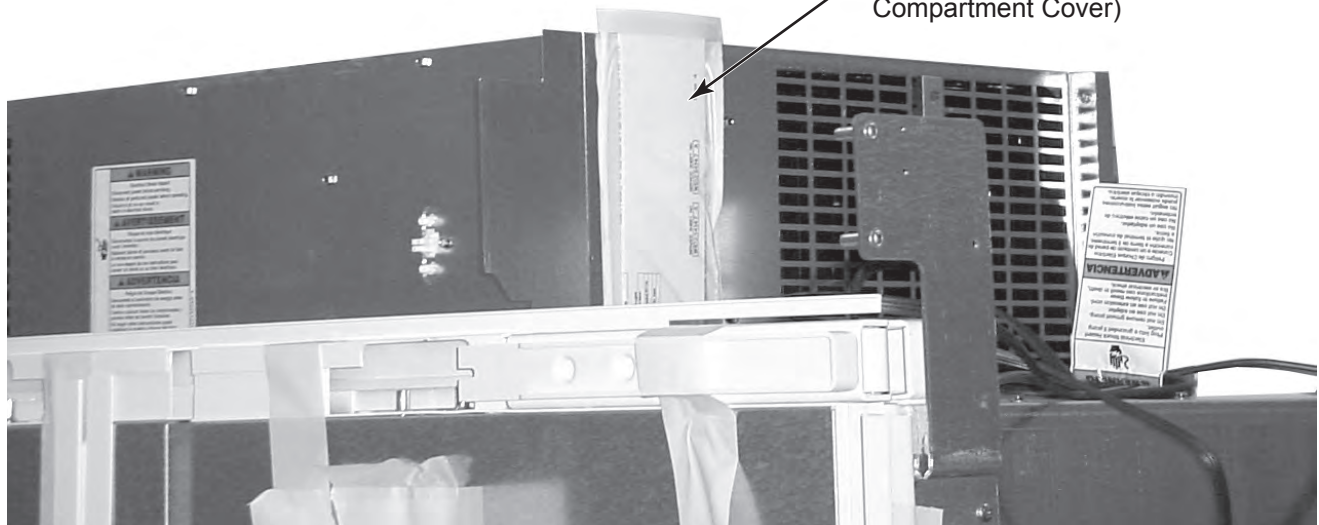

BOTTOM MOUNT FEATURES

JB36NXFXLW00, JB36NXFXRW00



FRENCH DOOR FEATURES JF42NXFXDW00



SIDE BY SIDE FEATURES



— NOTES —

INSTALLATION INFORMATION

Installation Requirements

Your safety and the safety of others are very important.

We have provided many important safety messages in this manual and on your appliance. Always read and obey all safety messages.



This is the safety alert symbol.

This symbol alerts you to potential hazards that can kill or hurt you and others.

All safety messages will follow the safety alert symbol and either the word "DANGER" or "WARNING."

These words mean:

⚠ DANGER

You can be killed or seriously injured if you don't immediately follow instructions.

⚠ WARNING

You can be killed or seriously injured if you don't follow instructions.

All safety messages will tell you what the potential hazard is, tell you how to reduce the chance of injury, and tell you what can happen if the instructions are not followed.

⚠ WARNING



Tip Over Hazard

Refrigerator is top heavy and tips easily when not completely installed.

Keep doors taped closed until refrigerator is completely installed.

Use two or more people to move and install refrigerator.

Failure to do so can result in death or serious injury.

⚠ WARNING

Excessive Weight Hazard

Use two or more people to move and install refrigerator.

Failure to do so can result in back or other injury.

Installation Requirements Models (continued)

36" MODELS

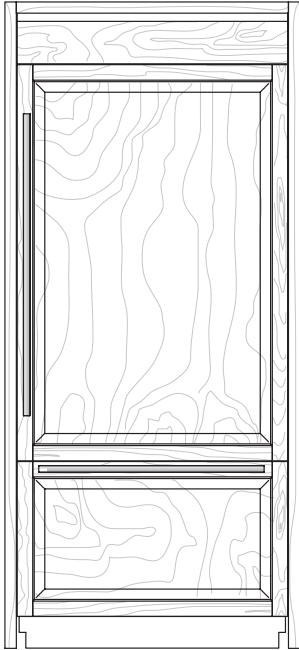

Integrated Design

Features custom-made panels and custom hardware provided by the cabinetmaker for a seamless appearance designed to blend with existing kitchen cabinetry.

Base Model Numbers: JB36NXFXLW, JB36NXFXRW

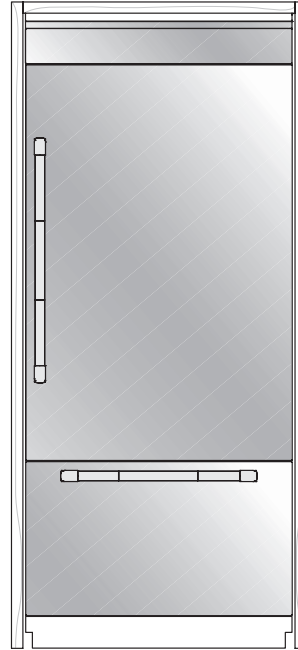

Pro-Style® Stainless Design

Features stainless steel wrapped doors and Pro-Style® handles with diamond-etched grip.

Base Model Numbers: JB36NXFXLW, JB36NXFXRW

Kit Model Number: JPK36BNXWPS



Euro-Style Stainless Design

Features stainless steel wrapped doors and new Euro-style handles designed to compliment the Jenn-Air Euro kitchen suite or enhance any kitchen decor.

Base Model Numbers: JB36NXFXLW, JB36NXFXRW

Kit Model Number: JPK36BNXWES

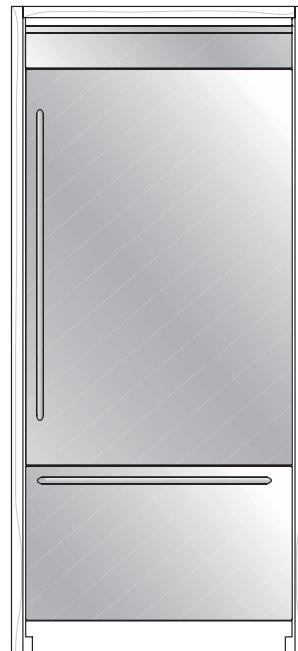

Classic Euro-Style Design

Features stainless steel wrapped doors with towel bar-style handles to enhance the traditional stainless kitchen appearance.

Base Model Number: JB36NXFXDW

Kit Model Number: JB36BNXWSS

Installation Requirements Models (continued)

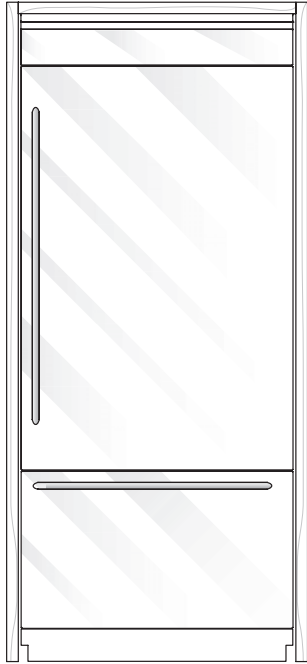

Floating Glass Design

Classic black or white glass panels that seemingly float in place with slightly curved, color coordinating handles that will compliment your contemporary kitchen.

Base Model Number: JB36NXFXDW

Kit Model Numbers: JPK36BNXWSY, JPK36BNXWSF

Accessories

All factory parts are available through your Jenn-Air dealer or by calling Jenn-Air at **1-800-JENNAIR (1-800-536-6247)**. In Canada, call **1-800-807-6777**.

Door Handle Kits

Follow the kit instructions for installation.

Pro-Style® Stainless Steel - BM W10250641

Euro-Style Stainless Steel - BM W10250635

Classic Euro-Style - BM W10250638

Armoire-Style Door Panel Kit

Follow the kit instructions for installation.

36" Model - W10292391

Installation Requirements Models (continued)

42" FRENCH DOOR MODELS

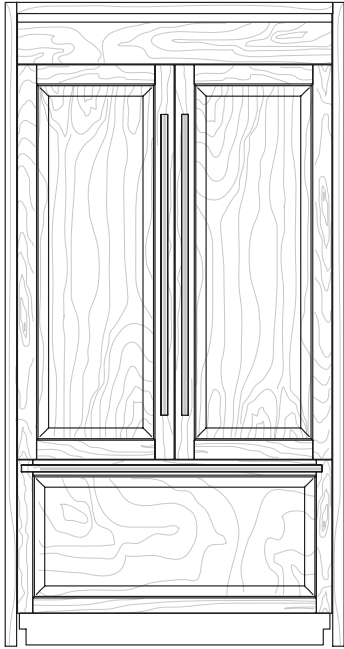

Integrated Design

Uses custom-made panels and custom hardware provided by the cabinetmaker for a seamless appearance designed to blend with existing kitchen cabinetry.

Base Model Number: JF42NXFXDW

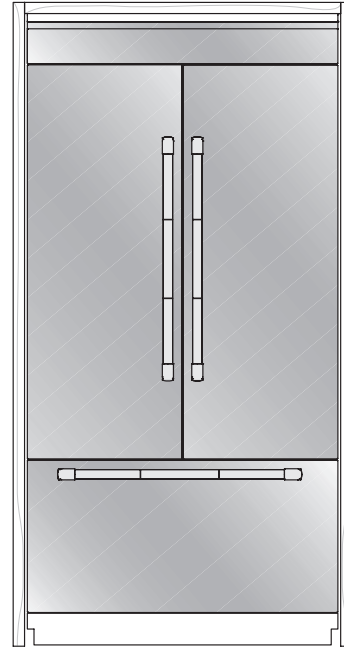

Pro-Style® Stainless Design

Features stainless steel wrapped doors and Pro-Style® handles with diamond-etched grip.

Base Model Number: JF42NXFXDW

Kit Model Number: JPK42FNXWPS

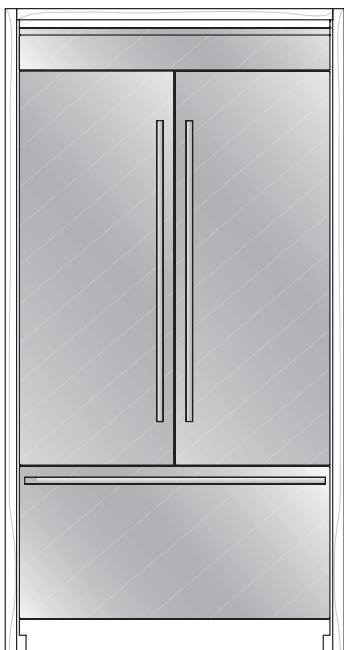

Euro-Style Stainless Design

Features stainless steel wrapped doors and new Euro-style handles designed to compliment the Jenn-Air Euro kitchen suite or enhance any kitchen decor.

Base Model Number: JF42NXFXDW

Kit Model Number: JPK42FNXWES

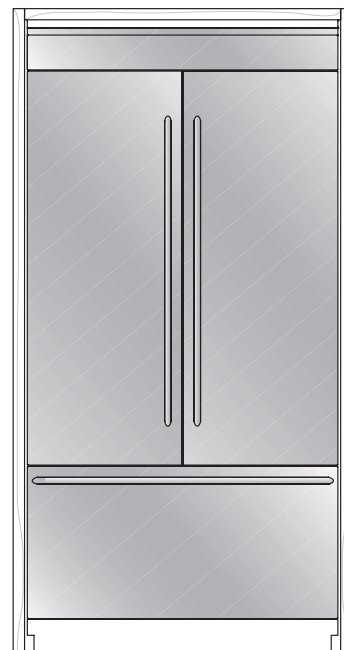

Classic Euro-Style Design

Features stainless steel wrapped doors with towel bar-style handles to enhance the traditional stainless kitchen appearance.

Base Model Number: JF42NXFXDW

Kit Model Number: JPK42FNXWSS

Installation Requirements Models (continued)



Oiled-Bronze Design

Features intricate copper strokes that integrate seamlessly into your kitchen while slightly curved matching handles add to the refrigerator's expressive form.

Base Model Number: JF42NXFXDW

Kit Model Number: JPK42FNXWSR

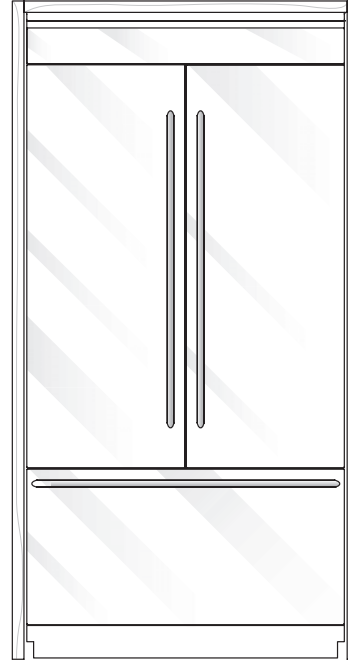

Floating Glass Design

Classic black or white glass panels that seemingly float in place with slightly curved, color coordinating handles that will compliment your contemporary kitchen.

Base Model Number: JF42NXFXDW

Kit Model Numbers: JPK42FNXWSY, JPK42FNXWSF

Accessories

All factory parts are available through your Jenn-Air dealer or by calling Jenn-Air at **1-800-JENNAIR (1-800-536-6247)**. In Canada, call **1-800-807-6777**.

Door Handle Kits

These handle kits can be ordered to use on custom wood overlay panels. Follow the kit instructions for installation.

Pro-Style® Stainless Steel FDBM - W10250642

Euro-Style Stainless Steel FDBM - W10250636

Classic Euro-Style FDBM - W10250639

Armoire-Style Door Panel Kit

Follow the kit instructions for installation.

42" Model - W10292393

INSTALLATION REQUIREMENTS

Tools and Parts

IMPORTANT:

- Installer: Leave Installation Instructions with the homeowner.
- Homeowner: Keep Installation Instructions for future reference. Save these Installation Instructions for the local electrical inspector's use.

TOOLS NEEDED:

Gather the required tools and parts before starting installation. Read and follow the instructions provided with any tools listed here.







- Cordless drill
- Drill bits
- Two adjustable wrenches
- Phillips screwdriver
- Small level
- $\frac{3}{32}$ " Allen wrench (panel kits only)
- $\frac{1}{32}$ " nut driver
- $\frac{3}{8}$ " and $\frac{1}{2}$ " open-end wrenches
- $\frac{5}{32}$ " and $\frac{3}{16}$ " Allen wrench
- $\frac{1}{4}$ " and $\frac{5}{16}$ " socket drivers
- Tape measure
- Utility knife
- Tape (painters)
- Appliance dolly



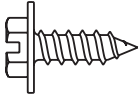

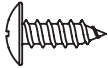

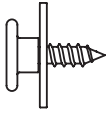
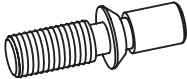
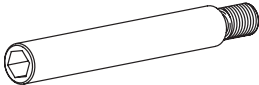
Installation Requirements (continued)

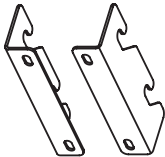
PARTS NEEDED:

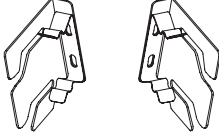
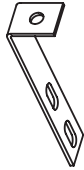
- Six #8 x 3" (7.6 cm) wood screws (longer screws may be needed)
- One or two 2" x 4" x 32" (5 cm x 10 cm x 81 cm) wood board(s)
- Custom wood overlay panels - consult a qualified cabinetmaker or carpenter to make the custom wood panels. See "Custom Wood Overlay Panels" for more information.
Panel kits - See "36" Models or 42" French Door Models" for panel kit information.
- Flexible, codes approved water supply tubing, a ferrule, a union and a 1/4" (6.35 mm) compression fitting.

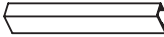
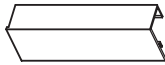
PARTS PROVIDED:

 <p>Slotted hex head screw</p> <p>W10141645 (21)</p>	 <p>Hex head pointed screw</p> <p>W10141189 (4)</p>
 <p>Hex head blunt screw</p> <p>W10142233 (4)</p>	 <p>Round head screw</p> <p>1163283 (24)</p>
 <p>Phillips head flat screw</p> <p>8281251 (28)</p>	 <p>Door panel stud</p> <p>W10129563</p>
 <p>Door Adjustment Pin</p> <p>W10234194</p>	 <p>Door Stop Pin</p> <p>W10234202</p>
 <p>Drawer Panel Bracket</p> <p>W10203457</p>	 <p>Standard Grille Bracket</p> <p>W10182743 - Left W10182741 - Right</p>

 <p>Integrated Grille Bracket</p> <p>W10260890 - Left W10260891 - Right</p>	 <p>"L" Bracket</p> <p>W10234199</p>
 <p>Panel top bracket</p> <p>W10192849</p>	 <p>Grille Trim</p> <p>W10250961 - 36" BM W10250962 - 42" BM, SxS W10250963 - 48" SxS</p>
 <p>RC Hinge Cover Trim</p> <p>W10199873 - 42" SxS W10199875 - 48" SxS W10202875 - 36" BM (Right) W10202510 - 42" FDBM (Right)</p>	 <p>FC Hinge Cover Trim</p> <p>W10199886 - 42" SxS W10199888 - 48" SxS W10202877 - 36" BM (Left) W10202511 - 42" FDBM (Left)</p>
 <p>Side Trim</p> <p>W10209363 - SxS W10207635 - 36" BM W10207633 - 36", 42" BM W10207632 - 36", 42" BM</p>	 <p>Handle Side Door Trim</p> <p>W10167367 - SxS W10188556 - BM (Left) W10202604 - BM (Right) W10202478 - FDBM (Right) W10202480 - FDBM (Left)</p>
 <p>Installation block</p> <p>W10234156</p>	<p>Panel templates</p> <p>W10222280 - SxS W10222278 - Bottom Mount W10222282 - Grille</p>

Installation Requirements (continued)

Location Requirements

⚠ WARNING



Explosion Hazard

Keep flammable materials and vapors, such as gasoline, away from refrigerator.

Failure to do so can result in death, explosion, or fire.

IMPORTANT:

- Observe all governing codes and ordinances.
- It is recommended that you do not install the refrigerator near an oven, radiator, or other heat source.
- Do not install in a location where the temperature will fall below 55°F (13°C).
- Floor must support the refrigerator weight, more than 600 lbs (272 kg), door panels and contents of the refrigerator.
- Ceiling height must allow for side tipping radius. See “Tipping Radius.”
- Location should permit door to open fully. See “Door Swing Dimensions.”
- Location must permit top grille removal. See “Opening Dimensions.”

Opening Dimensions

- The width of the opening, from side to side, must be as specified for your model, for at least 2" (5.08 cm) back from the face of the cabinet.

NOTE: If your opening does not meet this requirement, you will need to make modifications.
- A solid soffit or wall cabinet must be installed 84" (213.4 cm) above the floor. If the solid soffit is higher than 84" (213.4 cm) or one is not available, then the refrigerator must be braced.

If the anti-tip boards are needed, they must be attached to the rear wall studs so that there is 84" (213.4 cm) from the bottom of the anti-tip board to the floor. See “Install Anti-Tip Boards” for more information.
- For a fully integrated installation, a minimum of 6" (15.24 cm) of open space above the refrigerator is required. See “Fully Integrated Installation.” Anti-tip boards are required. See “Install Anti-Tip Boards” for more information.
- A grounded 3 prong electrical outlet should be placed within 4" (10.2 cm) of the right side cabinets or end panel. See “Electrical Requirements” for more information.
- The water shutoff should be located in the base cabinet on either side of the refrigerator or some other easily accessible area. If the water shutoff valve is not in the cabinets, the plumbing for the water line can come through the floor. See “Water Supply Requirements” for more information.

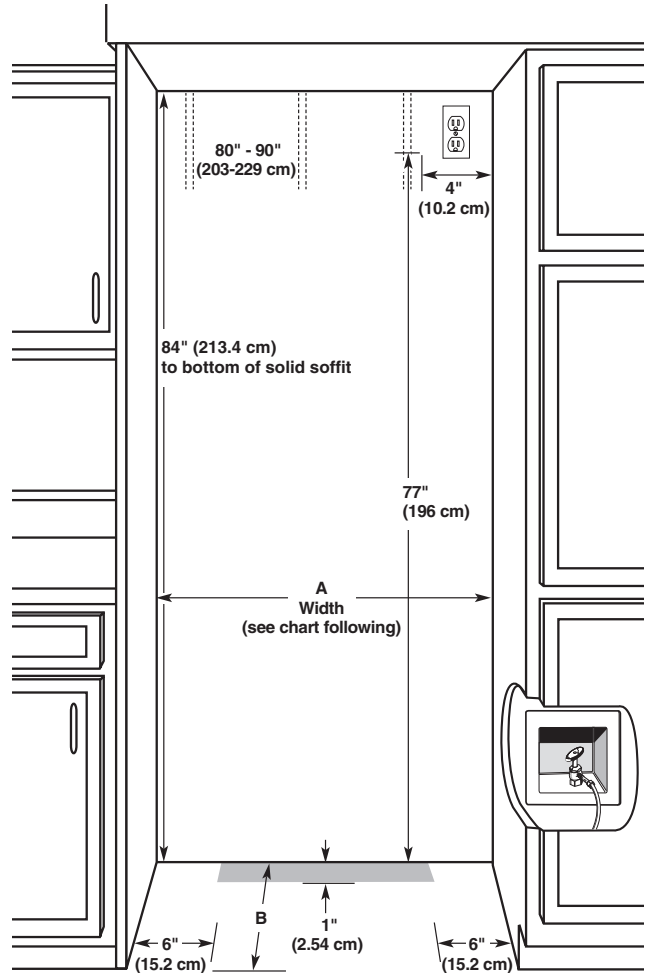

Model	Width A (as shown above)
36	36" (91.4 cm)
42	42" (106.7 cm)

Installation Type	Depth B (as shown above)
Standard Flush (new installation)	25" (63.5 cm) minimum
Retrofit Installations	24" (60.9 cm) minimum

IMPORTANT:

- The width of the opening (Width A), must be as specified for your model, for at least 2" (5.08 cm) back from the face of the cabinet.

NOTE: If your opening does not meet this requirement, you will need to make modifications.
- Flooring under refrigerator must be at same level as the room. Face of cabinetry must be plumb.

Installation Requirements (continued)

Electrical Requirements

⚠ WARNING



Electrical Shock Hazard

Plug into a grounded 3 prong outlet.

Do not remove ground prong.

Do not use an adapter.

Do not use an extension cord.

Failure to follow these instructions can result in death, fire, or electrical shock.

Before you move your refrigerator into its final location, it is important to make sure you have the proper electrical connection.

Recommended Grounding Method

A 115 Volt, 60 Hz., AC only, 15- or 20-amp fused, grounded electrical supply is required. It is recommended that a separate circuit serving only your refrigerator be provided. Use an outlet that cannot be turned off by a switch. Do not use an extension cord.

IMPORTANT: If this product is connected to a GFCI (Ground Fault Circuit Interrupter) protected outlet, nuisance tripping of the power supply may occur, resulting in loss of cooling. Food quality and flavor may be affected. If nuisance tripping has occurred, and if the condition of the food appears poor, dispose of it.

NOTE: Before performing any type of installation, cleaning, or removing a light bulb, remove the top grille and turn the master power switch to OFF or disconnect power at the circuit breaker box.

When you are finished, turn ON the master power switch or reconnect power at the circuit breaker box. Then reset the control to the desired setting.

Water Supply Requirements

- All installations must meet local plumbing code requirements.
- The water supply line must come up through the floor in the gray shaded area shown.
- The water shutoff should be located in the base cabinet on either side of the refrigerator or some other easily accessible area. The right-hand side is recommended.

NOTE: There is not enough clearance to achieve a flush installation if a water shutoff valve is located in the wall behind the refrigerator.

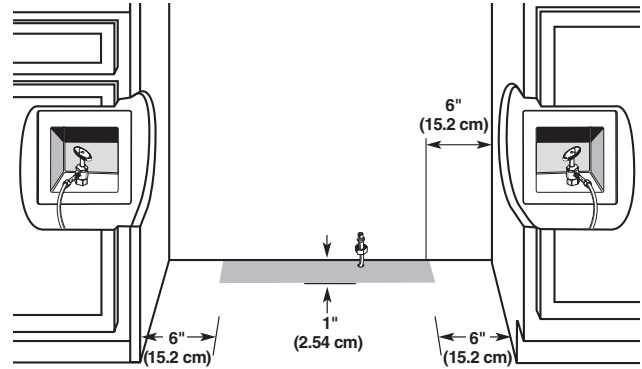

- A ½" (12.7 mm) hole for plumbing should be drilled at least 6" (15.2 cm) from the right or left hand side cabinet or panel. On the floor, the hole should be no more than 1" (2.54 cm) away from the back wall. See "Connect the Water Supply."
- If additional tubing is needed, use copper tubing and check for leaks. Install the copper tubing only in areas where the household temperatures will remain above freezing.
- Do not use a piercing-type or ⅜" (4.76 mm) saddle valve which reduces water flow and clogs more easily.
NOTE: Your refrigerator dealer has a kit available with a ¼" (6.35 mm) saddle-type shutoff valve, a union, and copper tubing. Before purchasing, make sure a saddle-type valve complies with your local plumbing codes.

Water Pressure

A cold water supply with water pressure between 30 and 120 psi (207 and 827 kPa) is required to operate the water dispenser and ice maker. If you have questions about your water pressure, call a licensed, qualified plumber.

Reverse Osmosis Water Supply

IMPORTANT: The pressure of the water supply coming out of a reverse osmosis system going to the water inlet valve of the refrigerator needs to be between 30 and 120 psi (207 and 827 kPa).

If a reverse osmosis water filtration system is connected to your cold water supply, the water pressure to the reverse osmosis system needs to be a minimum of 40 to 60 psi (276 to 414 kPa).

If the water pressure to the reverse osmosis system is less than 40 to 60 psi (276 to 414 kPa):

- Check to see whether the sediment filter in the reverse osmosis system is blocked. Replace the filter if necessary.
- Allow the storage tank on the reverse osmosis system to refill after heavy usage.
- If your refrigerator has a water filter, it may further reduce the water pressure when used in conjunction with a reverse osmosis system. Remove the water filter cartridge.

If you have questions about your water pressure, call a licensed, qualified plumber.

Installation Requirements (continued)

Product Dimensions

IMPORTANT:

- The depth from the front face of the doors to the back of the refrigerator cabinet is 24" (60.96 cm) without panels.
- The power cord is 84" (213 cm) long.
- The water supply line is located at the front of the refrigerator.

36" Bottom-Mount

Top View

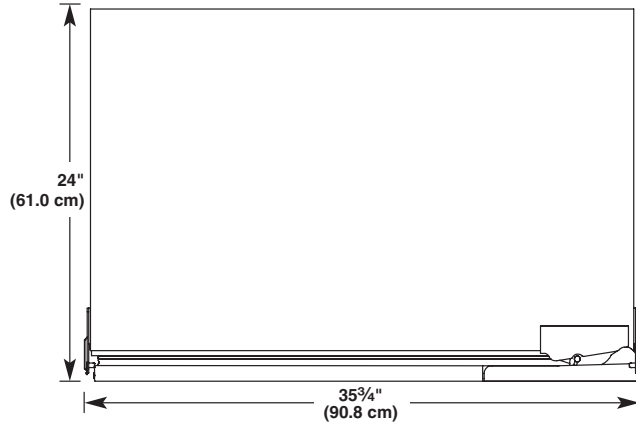

Front View

- Width dimensions were measured from hinge edge to clip edge.

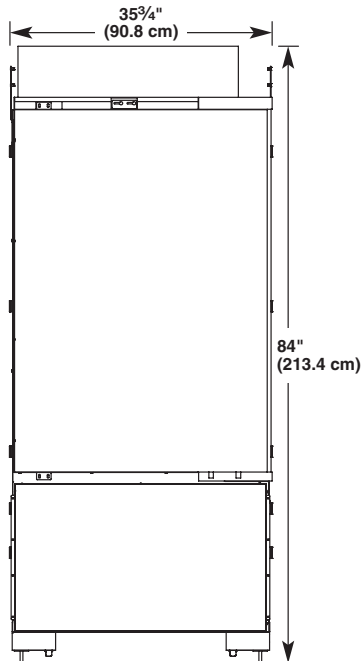

42" French-Door Bottom-Mount

Top View

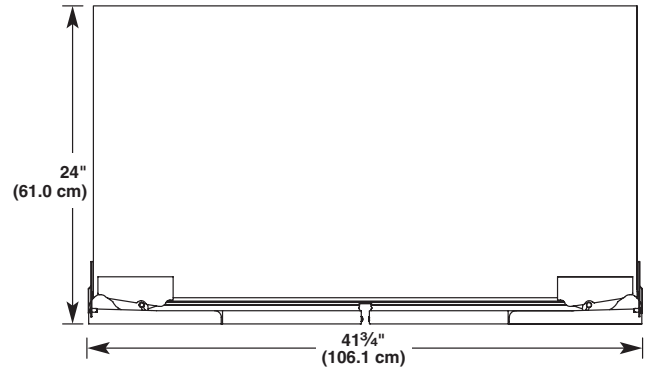

Front View

- Width dimensions were measured from hinge edge to hinge edge.

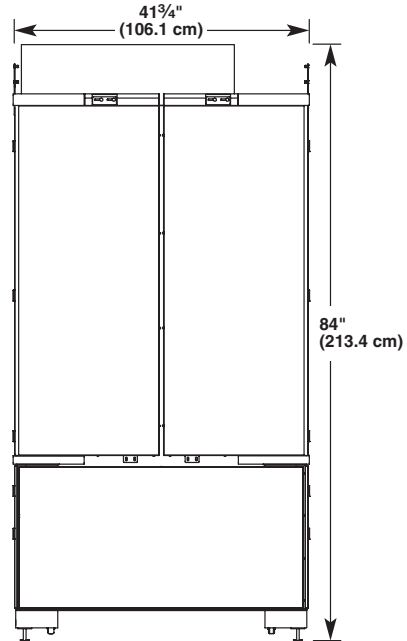

Tipping Radius

Be sure there is adequate ceiling height to stand the refrigerator upright when it is moved into place.

- The dolly wheel height must be added to the tipping radius when a dolly is used.
- If needed, the tipping radius can be reduced. See "Reduce Tipping Radius."

NOTE: Tip on side only.

Installation Requirements (continued)

Side Tipping Radius (36" [91.4 cm] Models)

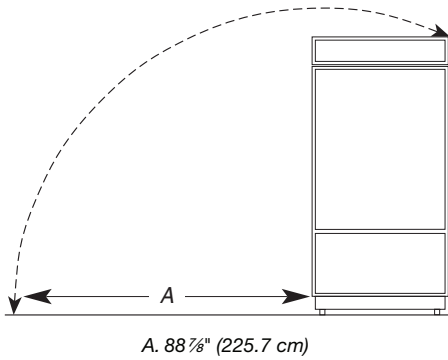

Side Tipping Radius (42" [106.7 cm] Models)

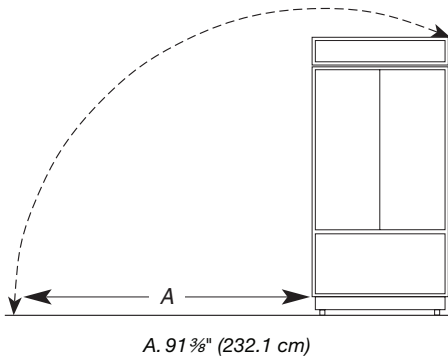

Door Swing Dimensions

The location must permit both doors to open to a minimum of 90°. Allow 4 1/2" (11.4 cm) minimum space between the side of the refrigerator and a corner wall.

NOTE: More clearance may be required if you are using custom wood overlay panels, custom handles, or extended handles.

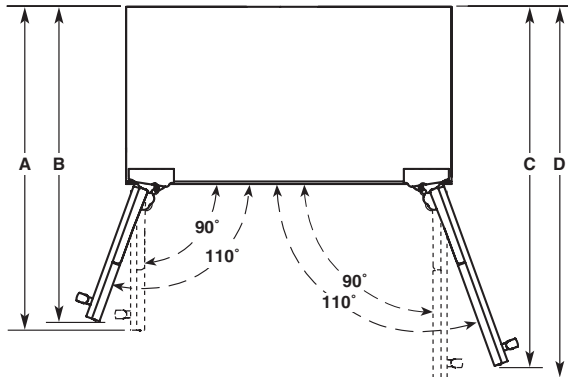

Model	A	B	C	D
36	36" (91.4 cm)	39 3/4" (101.0 cm)	45 5/8" (115.3 cm)	46 3/4" (118.8 cm)
42	42" (106.7 cm)	42" (106.7 cm)	48 5/8" (123.5 cm)	50 1/4" (127.6 cm)

Cabinet and Panel Installation Options

Cabinet Depth - 25" (63.5 cm)

Framed Cabinetry Top View

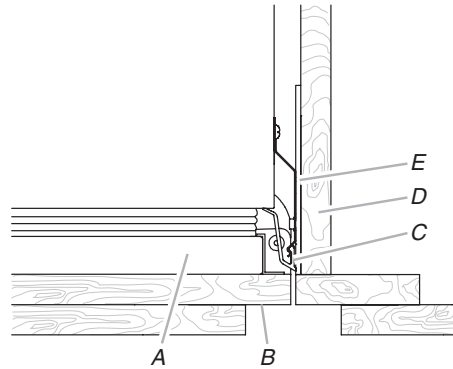

- A. Refrigerator door
- B. Overlay panel
- C. Side trim
- D. Adjacent cabinet
- E. Grille bracket

Top View - Inset

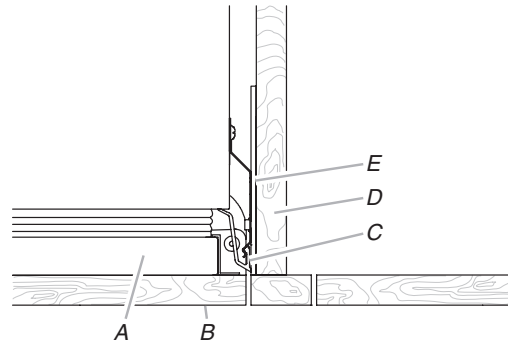

- A. Refrigerator door
- B. Overlay panel
- C. Side trim
- D. Adjacent cabinet
- E. Grille bracket

Frameless Cabinetry

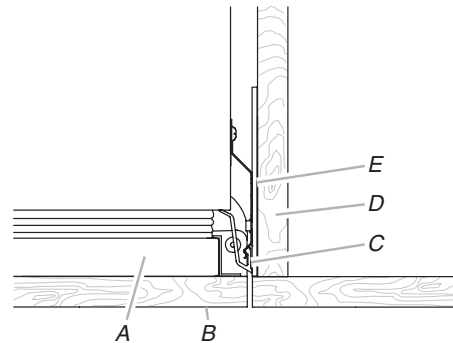

- A. Refrigerator door
- B. Overlay panel
- C. Side trim
- D. Adjacent cabinet
- E. Grille bracket

Installation Requirements (continued)

Cabinet Depth - 24" (60.9 cm)

NOTE: A flush installation is not possible with a 24" (60.9 cm) deep opening.

Framed Cabinetry

Top View

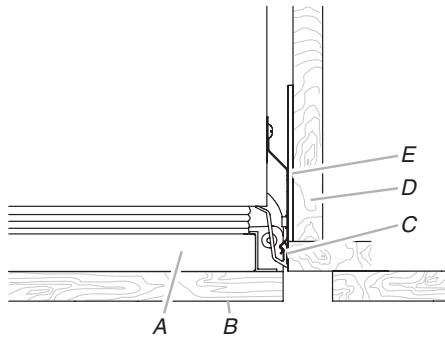

- A. Refrigerator door
- B. Overlay panel
- C. Side trim
- D. Adjacent cabinet
- E. Grille bracket

Frameless Cabinetry

Top View

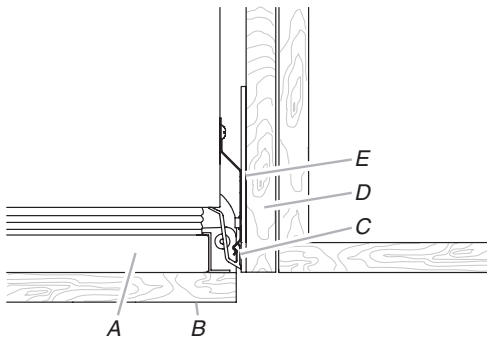

- A. Refrigerator door
- B. Overlay panel
- C. Side trim
- D. Adjacent cabinet
- E. Grille bracket

Fully Integrated Installation Requirements

The refrigerator can be installed fully integrated if the adjacent cabinetry meets the airflow venting requirements critical to refrigerator performance.

IMPORTANT:

- A Fully Integrated installation can be achieved with either a 24" (60.9 cm) or 25" (63.5 cm) deep opening.
- A full height grille is used to achieve a Fully Integrated installation. Use the integrated grille bracket (provided with refrigerator) to attach the full height grille.

NOTE: A top grille vent is not required with a full height grille.

Integrated Grille Bracket

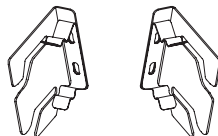

Fully Integrated Installation - Side View

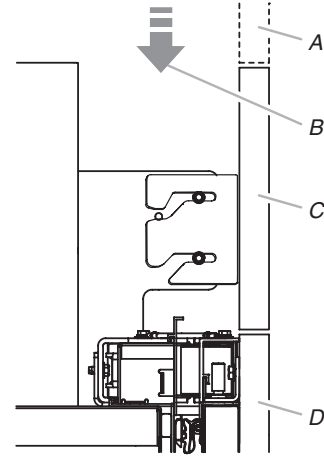

- A. False front (optional)
- B. Airflow
- C. Full height grille
- D. Door panel

Airflow Venting Requirements

Fully integrated installations require a minimum of 6" (15.24 cm) of open space above the refrigerator. This space must not be blocked in any way, including soffits.

Option 1 - Open to Ceiling

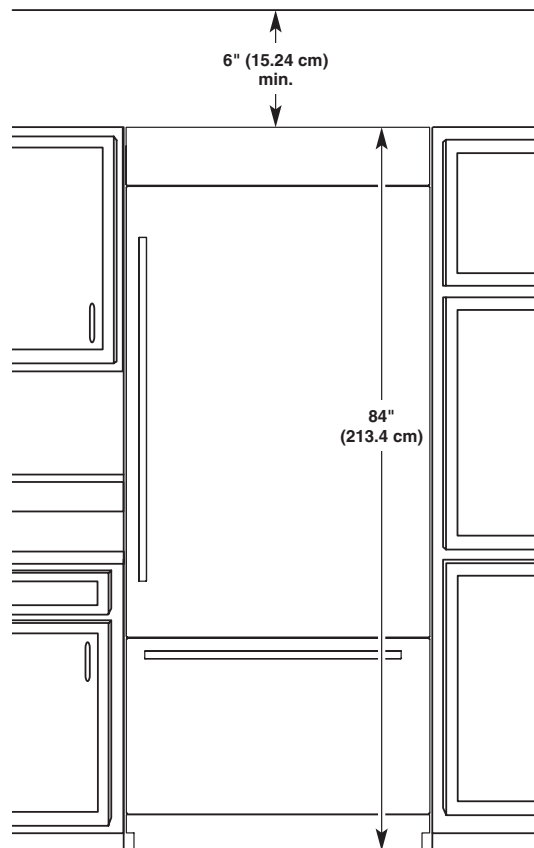

Installation Requirements (continued)

Option 2 - False Front (cabinet face only)

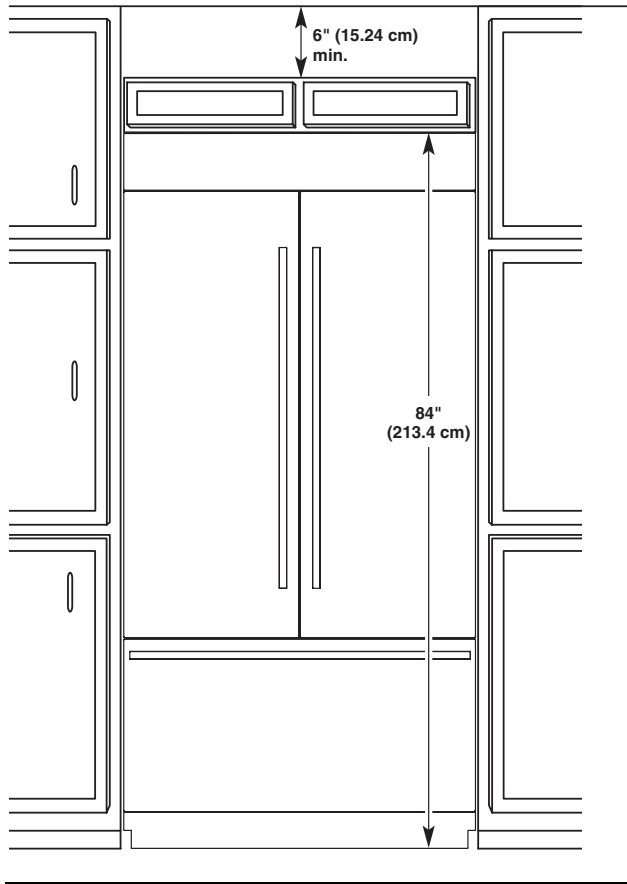

Standard Installation - Side View

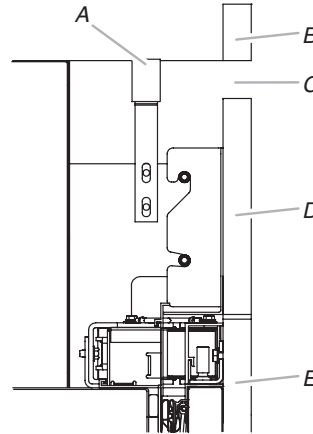

Standard Installation - Full Product View

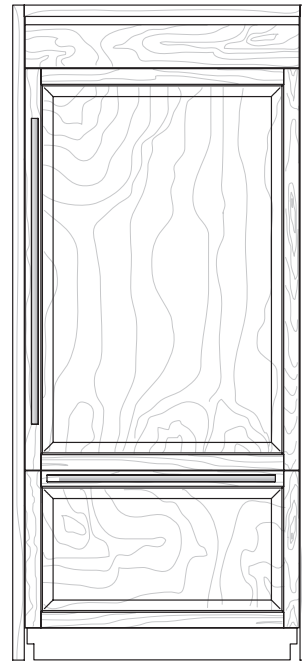

Standard Installation-Wood Panel Requirements

IMPORTANT:

- A Standard installation can be achieved with either a 24" (60.9 cm) or 25" (63.5 cm) deep opening.
- A standard grille is used to achieve a Standard installation. Use the standard grille bracket (provided with refrigerator) to attach the standard grille.
- The grille panel height, shown in the Standard Installation Flush Grille graphic, allows for an air gap critical to refrigerator performance.

Standard Grille Bracket

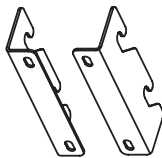

Panel Kit Installation Requirements

See the "36" Models" or the "42" French Door Models" section to see the panel kit options available for your model.

IMPORTANT:

- A Panel Kit installation can be achieved with either a 24" (60.9 cm) or 25" (63.5 cm) deep opening.
- A standard grille is used to achieve a Panel Kit installation. Use the standard grille bracket (provided with refrigerator) to attach the standard grille.
- The grille panel height, shown in the Standard Installation Flush Grille graphic, allows for an air gap critical to refrigerator performance.

Installation Instructions

Standard Grille Bracket

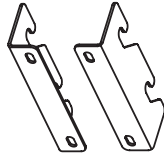

Panel Kit Installation - Side View

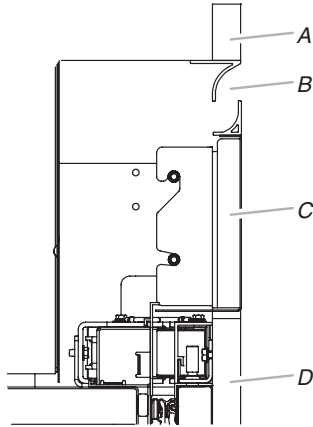

Panel Kit Installation - Full Product View

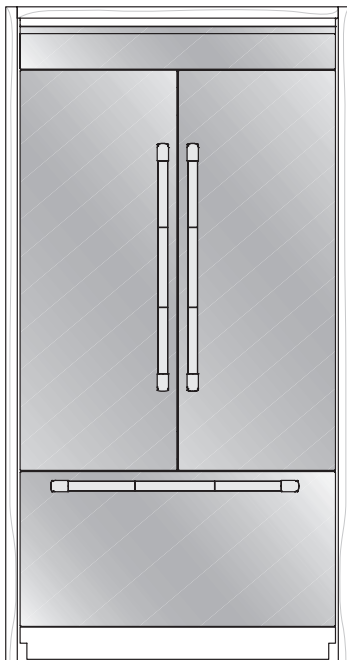

Custom Wood Overlay Panels

Custom wood overlay panels allow you to blend the exterior of your refrigerator into the overall kitchen décor and to use custom handles for additional design flexibility.

In some cases, your cabinet manufacturer may choose to work with one panel routed for the different dimensions. Follow these panel dimension and placement instructions to be sure that the custom wood overlay panels will fit properly.

IMPORTANT:

- For 36" (91.4 cm) models, the refrigerator door wood overlay panel cannot exceed 60 lbs (27.2 kg) and the freezer drawer overlay panel cannot exceed 25 lbs (11.3 kg).
- For 42" (106.7 cm) models, the refrigerator door wood overlay panel cannot exceed 38 lbs (17.2 kg) and the freezer drawer overlay panel cannot exceed 30 lbs (13.6 kg).
- The weight of the top grille wood overlay panel cannot exceed 7 lbs (3.2 kg) for both models.
- The required thickness for all panels is 3/4" (1.91 cm).
- This installation does not require filler or backer panels.

Custom Wood Overlay Panel Dimensions

36" (91.4 cm) Model - Door and Drawer Panels

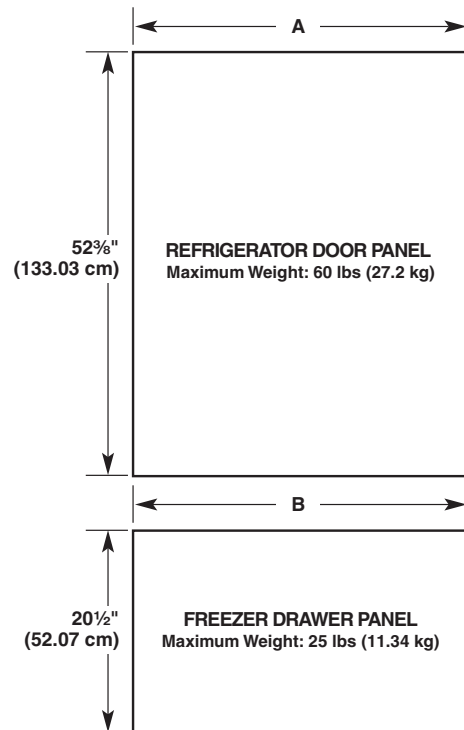

CAUTION

Pinch Hazard

Installation of door panels with less than a 3/8" (0.95 cm) gap between the door panel and the adjacent cabinet increases the risk of potential pinching.

Model	36" Bottom-Mount	
	3/8"	1/8"
A	35 1/4" (89.54 cm)	35 3/4" (90.81 cm)
B	35 1/4" (89.54 cm)	35 3/4" (90.81 cm)

Installation Instructions (continued)

42" (106.7 cm) Model - Door and Drawer Panels

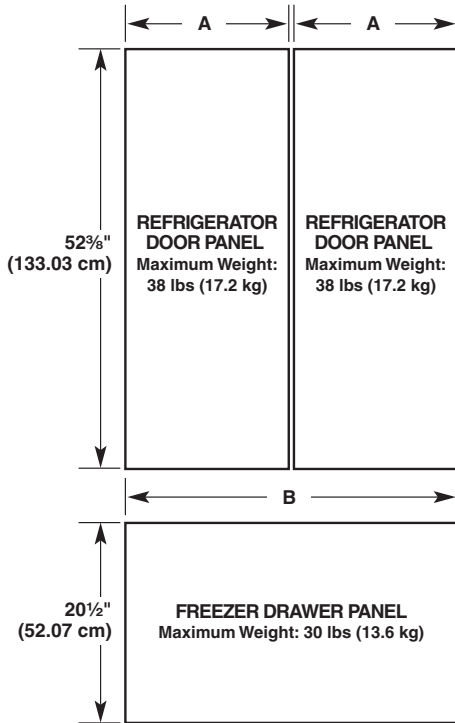

CAUTION

Pinch Hazard

Installation of door panels with less than a $\frac{3}{8}$ " (0.95 cm) gap between the door panel and the adjacent cabinet increases the risk of potential pinching.

Model	42" French Door Bottom-Mount	
Reveal	$\frac{3}{8}$ "	$\frac{1}{8}$ "
A	20 $\frac{9}{16}$ " (52.23 cm)	20 $\frac{13}{16}$ " (52.86 cm)
B	41 $\frac{1}{4}$ " (104.76 cm)	41 $\frac{3}{4}$ " (106.05 cm)

Grille Panel

Integrated Installation - Full Height Grille - Open Soffit



Model	36		42	
Reveal	$\frac{3}{8}$ "	$\frac{1}{8}$ "	$\frac{3}{8}$ "	$\frac{1}{8}$ "
C	35 $\frac{1}{4}$ " (89.54 cm)	35 $\frac{3}{4}$ " (90.81 cm)	41 $\frac{1}{4}$ " (104.76 cm)	41 $\frac{3}{4}$ " (106.05 cm)

Standard Installation - Flush Grille - Open or Closed Soffit

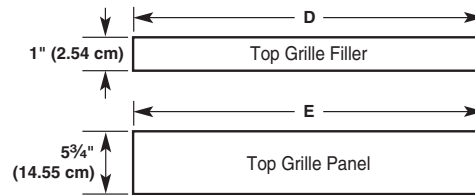

Model	36		42	
Reveal	$\frac{3}{8}$ "	$\frac{1}{8}$ "	$\frac{3}{8}$ "	$\frac{1}{8}$ "
D	35 $\frac{1}{4}$ " (89.54 cm)	35 $\frac{3}{4}$ " (90.81 cm)	41 $\frac{1}{4}$ " (104.76 cm)	41 $\frac{3}{4}$ " (106.05 cm)
E	35 $\frac{1}{4}$ " (89.54 cm)	35 $\frac{3}{4}$ " (90.81 cm)	41 $\frac{1}{4}$ " (104.76 cm)	41 $\frac{3}{4}$ " (106.05 cm)

IMPORTANT: The grille panel height, shown in the Standard Installation Flush Grille graphic, allows for an air gap critical to refrigerator performance.

INSTALLATION INSTRUCTIONS

Unpack the Refrigerator

WARNING



Tip Over Hazard

Refrigerator is top heavy and tips easily when not completely installed.

Keep doors taped closed until refrigerator is completely installed.

Use two or more people to move and install refrigerator.

Failure to do so can result in death or serious injury.

IMPORTANT:

- Do not remove the film covering until the refrigerator is in its operating location.
 - All four leveling legs must contact the floor to support and stabilize the full weight of the refrigerator.
 - Keep the cardboard shipping piece or plywood under the refrigerator until it is installed in the operating location.
- Remove and save the literature package and hardware kit located inside the refrigerator. Remove and save the literature, grille, and trim taped to the outside of the refrigerator.

NOTE: Do not remove tape and door bracing until the refrigerator is in its final location.

Installation Instructions (continued)

Move the Refrigerator into House

⚠ WARNING



Tip Over Hazard

Refrigerator is top heavy and tips easily when not completely installed.

Keep doors taped closed until refrigerator is completely installed.

Use two or more people to move and install refrigerator.

Failure to do so can result in death or serious injury.

1. Place an appliance dolly under the left side of the refrigerator as shown. Place the corner posts from the packing materials over the trims as appropriate. Slowly tighten the strap.

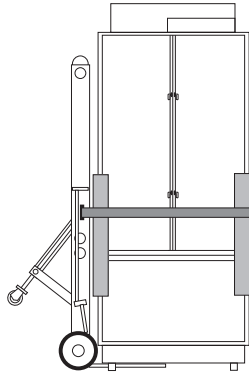

2. Place pieces of the shipping carton on the floor when rolling the dolly and refrigerator into the house. Move the refrigerator close to the built-in opening.
3. Place top of cardboard carton or plywood under refrigerator.
4. Stand the refrigerator up. First, place the left bottom edge of the refrigerator on the floor, stand the refrigerator upright and then lower the right-hand side of the refrigerator to the floor.

Install Anti-Tip Boards

IMPORTANT:

- If a solid soffit is not available, an anti-tip board must be installed.
- It is recommended that board(s) be installed before the refrigerator is installed.
- Board(s) must be long enough to fully cover the width of the compressor cover.
- Locate the board(s) so the bottom surface(s) of the board(s) is(are) 84" (213 cm) from the floor.
- During installation, raise the refrigerator up until the top of the refrigerator is making contact with the bottom of the anti-tip board(s). Do not crush the compressor cover when raising the rear leveling legs.

To Install Anti-tip Boards

1. Mark the stud locations on rear wall 80" to 90" (203 cm to 229 cm) above floor.
2. Securely attach one or two 2" x 4" x 32" (5 cm x 10 cm x 81 cm) boards to wall studs behind refrigerator. Use six #8 x 3" (7.6 cm) (or longer) wood screws. The wood screws must be screwed into the studs at least 1½" (3.8 cm). The board(s) must overlap the compressor cover.

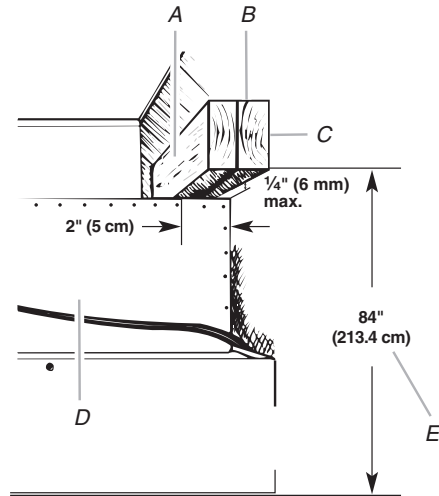

- A. Center board ¼" (6.35 mm) max. above refrigerator
 B. Two 2" x 4" x 32" (5 cm x 10 cm x 81 cm) boards
 C. Attach to studs with six #8 x 3" (7.6 cm) screws
 D. Compressor cover
 E. Distance from bottom of anti-tip board to floor

Connect the Water Supply

Read all directions before you begin.

IMPORTANT: If you turn the refrigerator on before the water line is connected, turn the ice maker OFF.

Connect to Water Line

Parts Needed:

- Minimum 7 ft (2.13 m) flexible, codes approved water supply line

Style 1 - Shutoff Valve Connection

NOTE: If your water line connection does not look like Style 1, see "Style 2 - Copper Line Connection."

1. Unplug refrigerator or disconnect power supply.

IMPORTANT: Before attaching the tubing to shutoff valve, flush the main water supply line to remove particles and air in the water line. Allow enough flow so that water becomes clear. Flushing the water line may help avoid filters and/or water valves from becoming clogged.

Installation Instructions (continued)

- Connect the flexible, codes approved water supply line to the water shutoff valve by threading the provided nut onto the shutoff valve as shown.

NOTE: The shutoff valve shown is in the side cabinet as recommended.

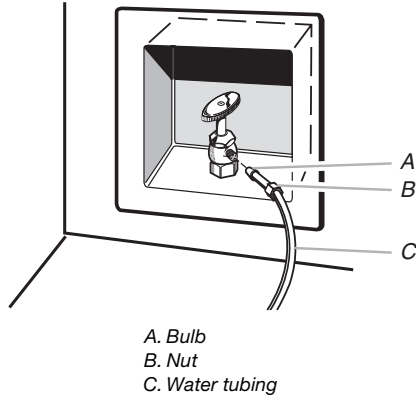

- Place the end of the tubing into a bucket, and turn shutoff valve ON.
- Check for leaks. Tighten any nuts or connections (including connections at the valve) that leak.

Style 2 - Copper Line Connection

NOTE: If there is a water supply line that meets the specifications in "Water Supply Requirement" proceed to "Connecting to Refrigerator." If not, use the following instructions to connect to the household cold water supply.

- Unplug refrigerator or disconnect power.
- Turn OFF main water supply. Turn ON nearest faucet long enough to clear line of water.
- Locate a 1/2" to 1 1/4" (1.25 cm to 3.18 cm) vertical cold water pipe near the refrigerator.

IMPORTANT:

- Make sure it is a cold water pipe.
 - Horizontal pipe will work, but drill on the top side of the pipe, not the bottom. This will help keep water away from the drill and normal sediment from collecting in the valve.
- Determine the length of copper tubing you need. Measure from the connection on the lower left rear of refrigerator to the water pipe. Add 7 ft (2.1 m) to allow for cleaning. Use 1/4" (6.35 mm) O.D. (outside diameter) copper tubing. Be sure both ends of copper tubing are cut square.
 - Using a cordless drill, drill a 1/4" (6.35 mm) hole in the cold water pipe you have selected.

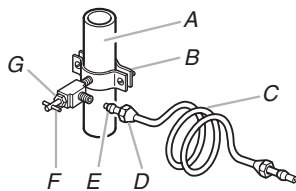

- A. Cold water pipe
B. Pipe clamp
C. Copper tubing
D. Compression nut
E. Compression sleeve
F. Shutoff valve
G. Packing nut

- Fasten the shutoff valve to the cold water pipe with the pipe clamp. Be sure the outlet end is solidly in the 1/4" (6.35 mm) drilled hole in the water pipe and that the washer is under the pipe clamp. Tighten the packing nut. Tighten the pipe clamp screws slowly and evenly so washer makes a watertight seal. Do not overtighten.

IMPORTANT: Before attaching the tubing to shutoff valve, flush the main water supply line to remove particles and air in the water line. Allow enough flow so that water becomes clear. Flushing the water line may help avoid filters and/or water valves from becoming clogged.

- Slip the compression sleeve and compression nut on the copper tubing as shown. Insert the end of the tubing into the outlet end squarely as far as it will go. Screw compression nut onto outlet end with adjustable wrench. Do not overtighten the clamp or the sleeve. This will crush the copper tubing.
- Turn off the shutoff valve on the water pipe. Coil the copper tubing.
- Connect the flexible, codes approved water supply line to the water shutoff valve by threading the provided nut onto the shutoff valve.
- Place the end of the tubing into a bucket, and turn shutoff valve ON.
- Check for leaks around the saddle valve. Tighten any nuts or connections (including connections at the valve) that leak.

Connect to Refrigerator

Parts Supplied:

- 1/4" to 1/4" (6.35 mm to 6.35 mm) male-to-male coupling

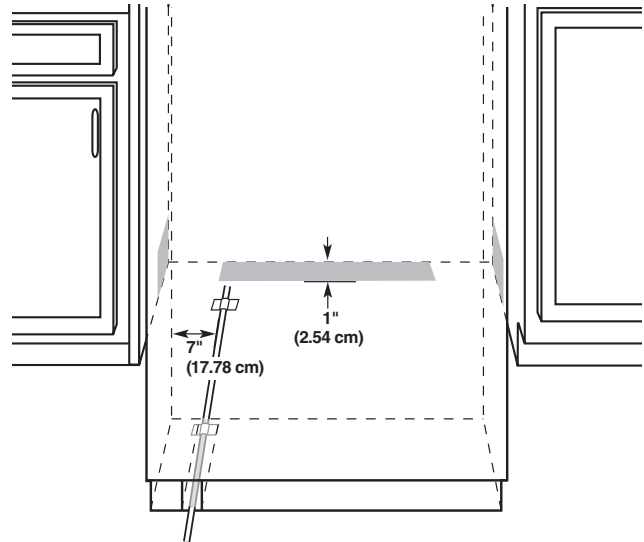

NOTE: The flexible, codes approved water supply line can connect to the supply valve through the floor or through the side cabinets, as indicated by the gray boxes above.

- Unplug the refrigerator or disconnect power.
- Connect the 7 ft (2.13 m) flexible codes approved water tube to the water supply valve.
- Flush the main water supply line to remove particles and air in the water line. Allow enough flow so that water becomes clear.
- Tape the 7 ft (2.13 m) flexible codes approved water supply line to the floor, 7" (17.78 cm) from the left side of the refrigerator. Tape along the length of the tubing, which will allow it to pass beneath the refrigerator without interference.

NOTE: Allow a minimum of 26" (66.04 cm) of flexible codes approved water supply line to be loose at the front of the refrigerator for connecting to the refrigerator.

Installation Instructions (continued)

- Connect the 7 ft (2.13 m) flexible codes approved water supply line to the refrigerator.

NOTE: If the main water shutoff valve is behind the refrigerator, a secondary water shutoff valve may be installed in line with the water supply line at the front of the product.

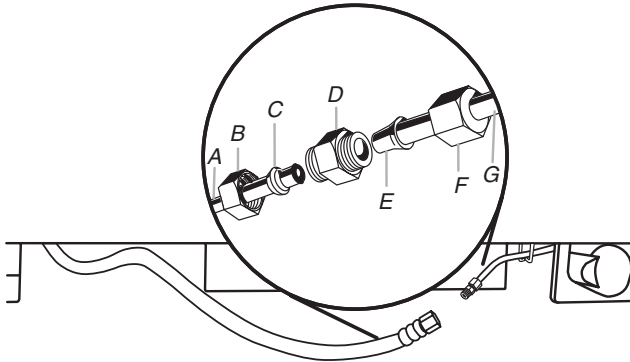

- | | |
|-------------------------|------------------------------|
| A. Household water line | E. Bulb |
| B. Nut (purchased) | F. Nut |
| C. Ferrule (purchased) | G. Refrigerator water tubing |
| D. Coupling | |

- Turn on the water supply valve and check all connections for leaks.
- Plug in the refrigerator or reconnect power.
- Flush the water system. See "Water System Preparation."

NOTE: Allow 24 hours to produce the first batch of ice. Discard the first three batches of ice produced. Allow 3 days to completely fill ice container.

Plug in Refrigerator

⚠ WARNING



Electrical Shock Hazard

Plug into a grounded 3 prong outlet.

Do not remove ground prong.

Do not use an adapter.

Do not use an extension cord.

Failure to follow these instructions can result in death, fire, or electrical shock.

- Set control switch at top of cabinet to the OFF position.
- Plug into a grounded 3 prong outlet.

Move Refrigerator to Final Location

⚠ WARNING



Tip Over Hazard

Refrigerator is top heavy and tips easily when not completely installed.

Keep doors taped closed until refrigerator is completely installed.

Use two or more people to move and install refrigerator.

Failure to do so can result in death or serious injury.

IMPORTANT:

- To avoid floor damage, make sure levelers are raised (not touching floor) and refrigerator is on rollers before moving.
- Use the installation block, attached to the door hinge, as a reference to make sure the refrigerator is pushed back far enough into the opening, so that when the panels are installed they will be flush with the adjacent cabinets.

NOTE: A flush installation is not possible with a 24" (60.9 cm) deep opening.

- After the refrigerator is leveled and aligned, remove the installation block from the door hinge and use it to check the spacing between the panels and adjacent cabinets.

NOTE: The installation block is designed to provide accurate spacing for $\frac{3}{4}$ " (1.9 cm), $\frac{3}{8}$ " (9.53 mm) and $\frac{1}{8}$ " (3.18 mm).

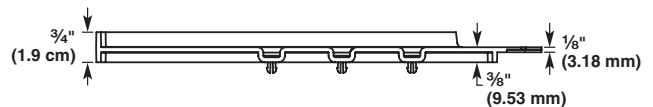

- Place top of cardboard carton or plywood under refrigerator. Remove dolly.
- Move the refrigerator straight back and evenly into the opening. Be sure that the water tubing is not kinked and the power supply cord is on top of the refrigerator.
NOTE: If the power supply cord is behind the refrigerator, it will not install properly.
- Make sure the installation block is flush with the adjacent cabinets.

Installation Instructions (continued)

NOTE: To achieve a flush installation, it is critical to verify a $\frac{3}{4}$ " (1.9 cm) depth from the front face of the adjacent cabinetry to the refrigerator.

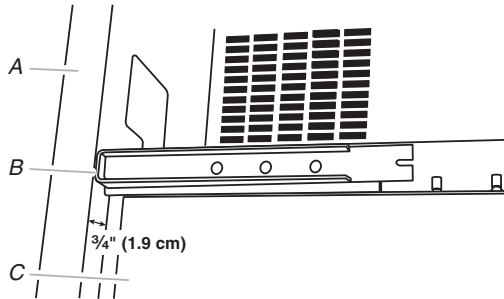

A. Adjacent cabinet or wall
B. Installation block
C. Face of refrigerator

- Continue adjusting all of the leveling legs to raise the refrigerator until the top is within at least $\frac{1}{4}$ " (6.35 mm) of the top soffit as shown.

NOTE: If an anti-tip board has been used, adjust the leveling legs until the top of the refrigerator is making contact with the bottom of the anti-tip board(s). Do not crush the compressor cover.

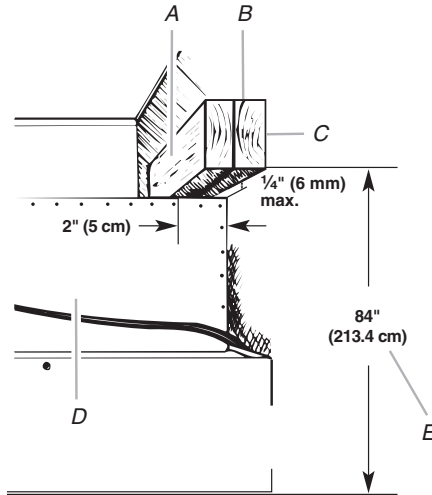

A. Center board $\frac{1}{4}$ " (6.35 mm) max. above refrigerator
B. Two 2" x 4" x 32" (5 cm x 10 cm x 81 cm) boards
C. Attach to studs with six #8 x 3" (7.6 cm) screws
D. Compressor cover
E. Distance from bottom of anti-tip board to floor

Level and Align Refrigerator

⚠ WARNING



Tip Over Hazard

Refrigerator is top heavy and tips easily when not completely installed.

Keep doors taped closed until refrigerator is completely installed.

Use two or more people to move and install refrigerator.

Failure to do so can result in death or serious injury.

IMPORTANT: All four leveling legs must contact the floor to support and stabilize the full weight of refrigerator. Rollers are for moving refrigerator and not for permanent support.

After moving the refrigerator to its final location:

- Use a $\frac{5}{16}$ " socket driver to turn the leveling bolts clockwise to extend the legs to the floor as shown. The rollers should be off the floor.

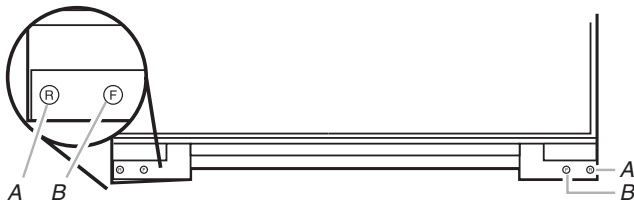

A. Rear leveling bolt
B. Front leveling bolt

- Adjust the leveling legs to level and align the refrigerator from left to right and front to back so that the refrigerator is level and aligned with the cabinets.

IMPORTANT: Adjust in small increments to keep from damaging the cabinet trim and causing problems with the door alignment or top grille fit. To avoid damage to the cabinet or leveling legs, do not apply more than 50 inch-pounds (5.65 Nm) of torque to the leveling bolts. The leveling legs can be extended to a maximum of $1\frac{1}{4}$ " (3.18 cm) below the rollers.

- After leveling the refrigerator, use a straight edge or 4 foot level going across the front of the refrigerator installation to the cabinets to check that the refrigerator is still flush.

Install Refrigerator and Panels

IMPORTANT: Jenn-Air is not responsible for the removal or addition of molding or wood overlay panels that would not allow access to the refrigerator for service.

Install Refrigerator to Adjacent Cabinets

- Open the refrigerator door(s) and freezer drawer. On the hinge side(s), locate the cabinet brackets in the space between the door(s) and the refrigerator and the drawer and refrigerator.
- Using the holes in the brackets as a template, predrill $\frac{1}{8}$ " deep pilot holes into the adjacent cabinet.
- Using two round head screws (provided with refrigerator) for each bracket, insert the screws through the cabinet brackets and into the adjacent cabinetry to anchor the refrigerator.
- Repeat steps 2 and 3 to anchor the other side of the refrigerator to the adjacent cabinetry.

Install Cabinet Side Trims

Install cabinet side trims to hide the brackets fastening the refrigerator to the adjacent cabinets.

- Open the door(s) to a 90° angle.
- With the lip edge of the trim toward the back wall, insert the cabinet side trim between the side of the refrigerator and the adjacent cabinetry.

Installation Instructions (continued)

NOTE: Keep the top edge of the trim piece flush with the top of the refrigerator. If the trim is installed so that the top of the trim is higher than the top of the refrigerator, damage to the trim could occur when the refrigerator door is opened.

- Slide the trim toward the back until it snaps into place.

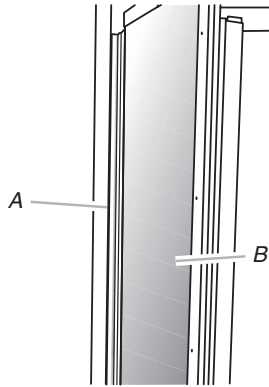

A. Cabinet side trim
B. Refrigerator door

Side View

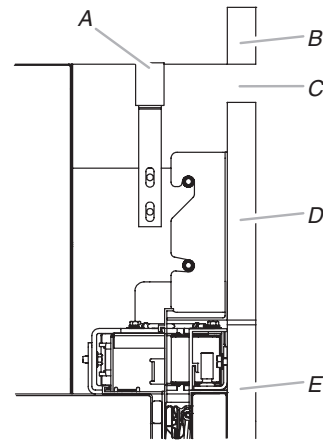

A. Top grille filler
B. Soffit
C. Airflow
D. Grille panel
E. Door panel

Install Top Grille Filler (standard installation only)

IMPORTANT: The grille panel height allows the necessary airflow for refrigerator performance. The top grille filler hides the upper compartment cover behind the top grille. If you choose to modify the recommended grille panel dimensions, performance will be compromised.

Custom Wood Panel Models

- In the custom made (1" x width of grille panel) wood filler piece, drill a hole $\frac{1}{16}$ " from each edge.
NOTE: Make sure the hole is centered in the 1" thickness of the wood piece.
- Using slotted hex head screws (provided with refrigerator), fasten an "L" bracket to each end of the wood filler piece.
- Using hex head blunt screws (provided with refrigerator), attach the "L" brackets to the top grille mounting plates.
- Adjust the "L" brackets, so that the wood filler piece is flush with the bottom of the soffit. Completely tighten the screws.

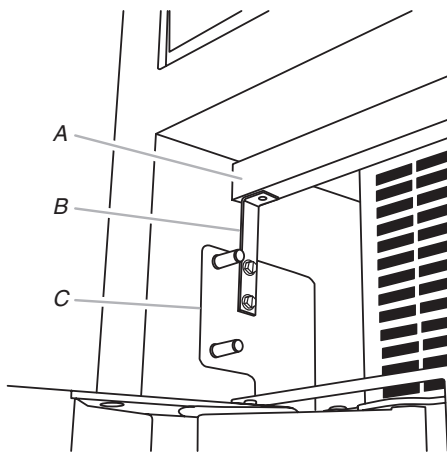

A. Custom wood filler
B. "L" bracket
C. Grille mounting plate

Panel Kit Models

⚠ WARNING

Excessive Weight Hazard

Use two or more people to move and install panels.
Failure to do so can result in back or other injury.

⚠ WARNING



Broken Glass Hazard

Do not hit refrigerator glass doors.
Protect glass surface and edges during installation or removal of doors.
Failure to do so can result in serious eye injury or minor cuts.

- Align top grille vent (provided in the door kit) with the bottom edge of the soffit. Use as a template, and mark where to drill the holes.
- Using slotted hex head screws (provided with refrigerator), attach the top grille vent to the soffit.

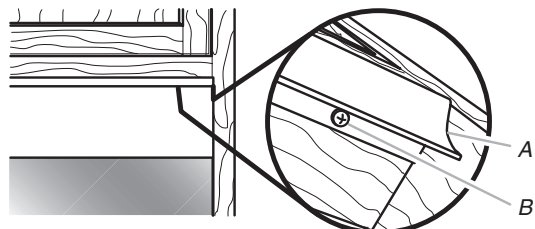

A. Top grille vent
B. Slotted hex head screw

Installation Instructions (continued)

Side View

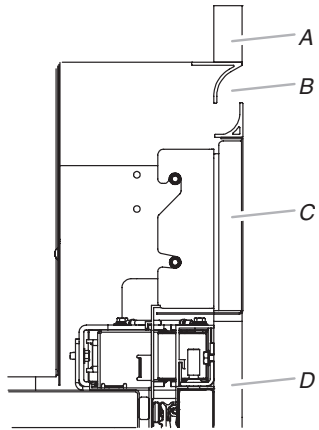

A. Soffit
B. Airflow
C. Grille panel
D. Door panel

Predrill Panels (custom wood panels only)

IMPORTANT: The template can be used for either a $\frac{3}{8}$ " (0.95 cm) or a $\frac{1}{8}$ " (0.32 cm) reveal installation.

- The drilling templates are used only for custom wood overlay panels.
 - The drilling templates are double-sided.
 - The drilling holes are precut into the template.
1. On the template, locate the diagram of your refrigerator. Then, follow the letters and colored arrows to correctly place the drilling template on the panels.
 2. Predrill $\frac{1}{8}$ " (0.32 cm) deep pilot holes into the wood rails bordering the door(s), drawer and top grille panels.

Predrill Panels (panel kits only)

IMPORTANT: The panels included in the panel kits are marked for the location of the mounting brackets only.

1. Predrill holes where marked. See "Complete Installation" later in this section, for instructions on drilling additional holes in the door panels.

NOTE: For 36" model door panel kits which are right-hand swing and left-hand swing specific use the following instructions:

- Hinge on right-hand side - Use the holes, located on the back side of the door panel, that are circled in red.
 - Hinge on left-hand side - Use the holes, located on the back side of the door panel, that are circled in blue.
2. Remove the film covering on stainless steel door panels before installing brackets.

Prepare Panels (custom wood and panel kits)

IMPORTANT: The process for installing wood overlay panels on the refrigerator is the same for both custom wood panels and panel kits.

Door Panel

1. Place panel(s) on a firm, flat surface with the front facing down.
2. Locate the two pre drilled holes in the handle side edge of the door panel.
3. Using the installation block as a guide for depth, screw the door studs (provided with refrigerator) into the pre drilled door panel (two door panel studs per door).

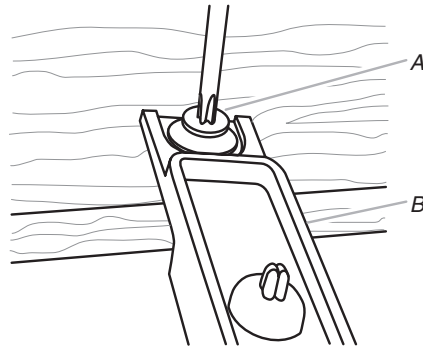

A. Door panel stud
B. Installation block

4. For the mounting bracket, insert the hex head pointed screws (provided with refrigerator) into the wood at the top of the door panels where they were pre drilled.

NOTES:

- It is critical to use the $\frac{5}{8}$ " screw, the longest length provided, to attach the bracket to the top of the door panel. These hex head pointed screws are used only to attach this mounting bracket.
 - Panel Kits - Find the holes to attach the hex head pointed screws by locating the slots in the door panel, not the U-shaped holes.
5. Attach a panel top bracket to the top edge of the door panel(s) by placing the large ends of the keyhole slots over the screws and sliding the bracket so that the screws are centered in the slots.

NOTE: Start with the screws in the center of the slots as shown, then move the door panel, as necessary, to align.

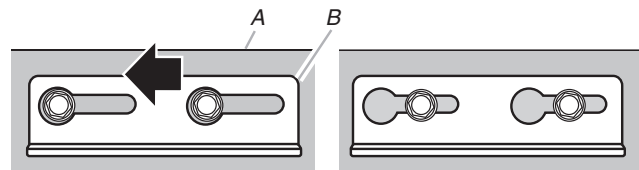

A. Door panel
B. Panel top bracket

Installation Instructions (continued)

Drawer Panel

1. Using the Phillips head flat screws (provided with refrigerator), fasten a drawer panel bracket to each side of the drawer panel, as shown.

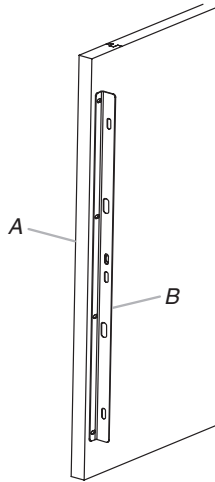

A. Drawer panel
B. Drawer panel mounting bracket

Top Grille Panel

1. Using the slotted hex head screws (provided with refrigerator), attach a mounting bracket to each side of the top grille panel.

IMPORTANT: See the Parts Provided insert sheet to select the brackets designated for your installation.

- Use the Integrated Grille brackets for an Integrated Installation with a full height grille.

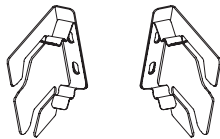

- Use the Standard Grille brackets for a Standard Installation with a flush grille, as shown.

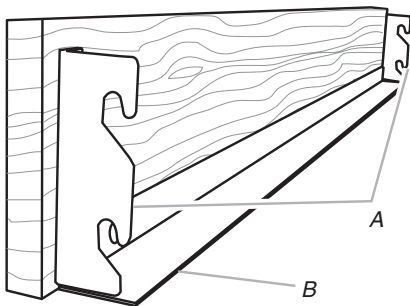

A. Top grille brackets
B. Grille trim piece

2. Using round head screws (provided with refrigerator), attach the grille trim piece to the bottom of the grill panel.

NOTE: The grille trim is pre installed on the panel kits.

Remove Trim Pieces

1. Remove all tape and door bracing from the refrigerator and freezer doors.
2. Open the refrigerator and freezer doors.
3. Remove the hinge cover trim pieces from the top and bottom of the door to expose the holes in the hinges.

NOTES:

- It is not necessary to remove the hinge side trims as they will not interfere with the installation
 - Leave the freezer drawer trims in place for installation.
4. Remove the handle side trims. See following graphic.

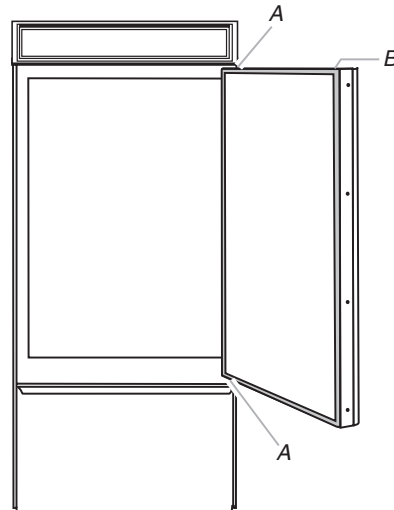

A. Hinge cover pieces
B. Handle-side door trim

Installation Instructions (continued)

Install Door Panels

NOTE: First open the door opposite from the one to which you are installing the door panel.

1. Lower the panel mounting bracket onto the adjustment pins at the top of the door.

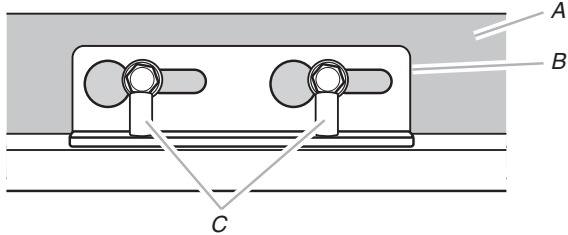

A. Door panel
B. Mounting bracket
C. Adjustment pins

2. Locate the studs on the back of the door panel. Slide the studs, top stud first followed by the bottom stud, into the “J” pockets in the front of the door.

NOTE: It is the washer in the stud, not the head of the stud, that is inserted in the “J” pocket.

3. Slide the door panel down, into the “J” pocket in the front of the door.

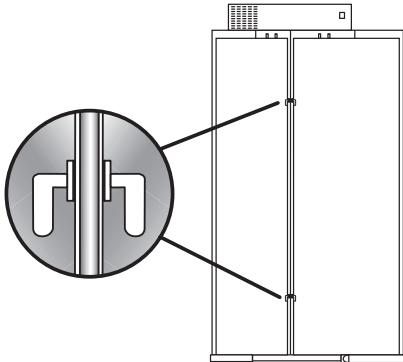

4. Repeat steps 1 through 3 to install the second door panel.
5. Using slotted hex head screws (provided with refrigerator), attach the mounting bracket (factory installed), located at the bottom of the refrigerator and freezer doors, to the respective door panels. Do not fully tighten the screw.

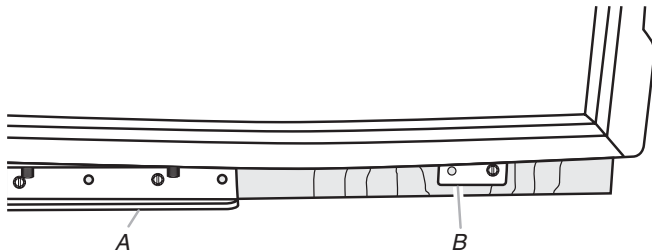

A. Bottom hinge
B. Mounting bracket

Install Top Grille Panel

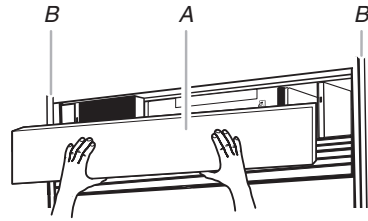

A. Top grille panel
B. Cabinet sides

Standard Installation - Flush Grille

1. Hook the panel brackets onto the mounting bolts extending from the top of the refrigerator.

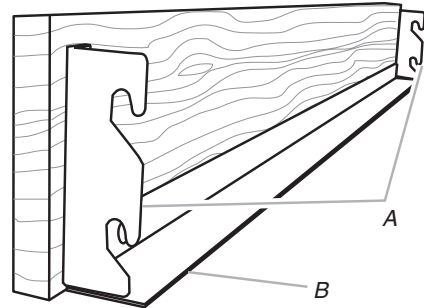

A. Panel brackets
B. Grill trim piece

2. Pull the grille panel down slightly to lock into place.

Integrated Installation - Full Height Grille

1. Align the bracket on each side of the top grille panel with the mounting bolts.

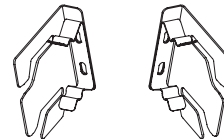

2. Push the grille panel forward until the bracket snaps into place.

Door Swing Adjustment

It may be necessary to adjust the swing of the door. Make sure the refrigerator door(s) can open freely. If the door(s) opens too wide, install the door stop pin (provided with refrigerator).

1. Hold the door open to a position that is less than 90°.
2. Insert the door stop pin into the top hinge in the hole shown.

Installation Instructions (continued)

- Using a $\frac{5}{32}$ " Allen wrench, tighten the door stop pin.

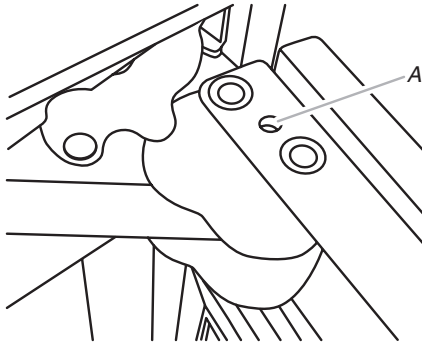

A. Door stop pin hole

Complete Installation

- Use the installation block to measure the gaps between the panels and adjacent cabinets.
 - Custom wood overlay panels may be made with a $\frac{3}{8}$ " (0.95 cm) or $\frac{1}{8}$ " (0.32 cm) gap between the panel and cabinets and a $\frac{1}{8}$ " (0.32 cm) gap between the freezer and refrigerator door(s) and the door(s) and top grille.
 - All purchased panel kits require a $\frac{3}{8}$ " (0.95 cm) gap between the panel and the cabinets and a $\frac{1}{8}$ " (0.32 cm) gap between the freezer and refrigerator door(s), and the door(s) and top grille.

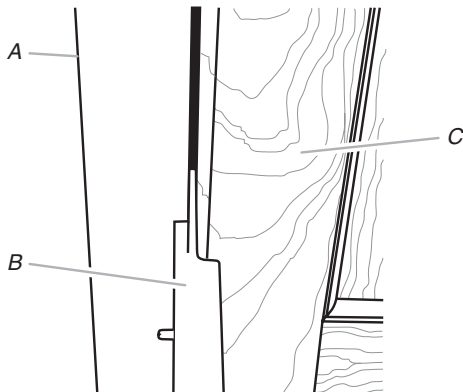

A. Adjacent cabinet
B. Installation block
C. Panel on door

- Adjust the panel to achieve the required spacing, or to align.

IMPORTANT: If adjustments are needed, adjust the panel not the door. Adjust left to right in the mounting bracket before using the pins to adjust the panel up and down or at an angle.

 - Slide the panel from side to side in the keyhole slot.

- Use an Allen wrench to raise or lower the adjustment pins which allows the door panel to swivel.

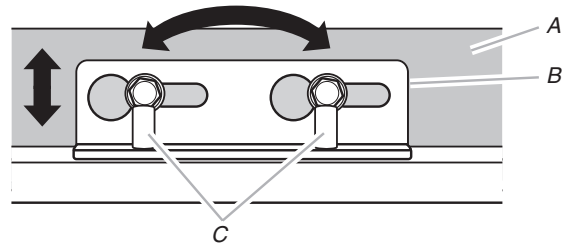

A. Door panel
B. Mounting bracket
C. Adjustment pins

- Predrill a $\frac{1}{8}$ " deep pilot hole the door panel through the open holes in both the bottom and top hinges.
- Using slotted hex head screws (provided with refrigerator), attach the top and bottom hinges to the door panels. Fully tighten all door panel screws.

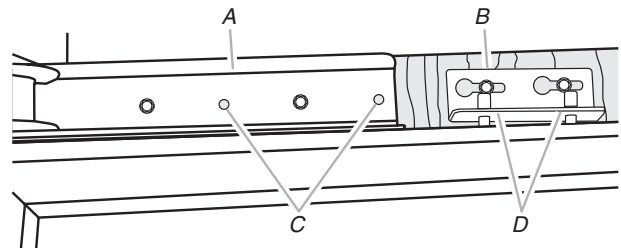

A. Top hinge
B. Mounting bracket
C. Holes for screws
D. Adjustment pins

- Using slotted hex head screws (provided with refrigerator) for each side, attach the door panels to the hinge-side door trims.
- Using Phillips head flat screws (provided with refrigerator), install the handle side door trim.
- Completely tighten the screws attaching the mounting brackets, located at the bottom of the doors, to the overlay panels.
- Reinstall the top door trim and hinge cover.
- Snap the adjustment pin cover (provided with refrigerator) into place.

Install Handles (Panel Kit Models Only)

IMPORTANT: Install the handles after the door panels have been installed. Follow the instructions specific to your door panel design.

Tools Needed: $\frac{3}{32}$ " Allen wrench

Door Panels - Custom Wood, Stainless Steel and Oiled Bronze Designs

- Locate the holes in the door panels where the handle mounting studs are to be installed.
- Fasten the handle mounting studs to the door panels.
- Install the handles to the handle mounting studs and tighten the setscrews.

Door Panels - Floating Glass Design

IMPORTANT: To align the handle correctly on the door, the plastic handle spacer and the setscrews on the door handle must be in the positions designated in the chart.

- Locate the holes in the door panels where the handle mounting studs are to be installed.

Installation Instructions (continued)

- Insert the circular post on the back of the handle spacers into the holes in the door panels.

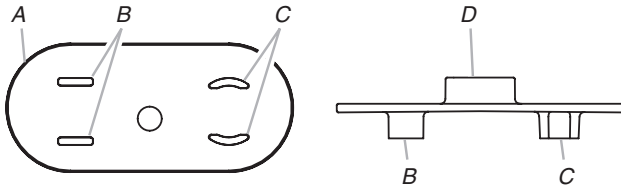

A. Plastic handle spacer
 B. Straight handle mounting posts
 C. Curved handle mounting posts
 D. Circular post

- Depending on the compartment, rotate the plastic spacer so that the curved handle mounting posts are either at the top or bottom. See following chart.

	Freezer Left-Hand Door	Refrigerator Right-Hand Door
Curved Mounting Post	Bottom	Top
Setscrews	Right	Left

- Slide the screw into the handle mounting stud. Insert the screw assembly into the center hole of the plastic spacer and fasten it to the door panel.
- Install the handles to the handle mounting studs so that the setscrews are on the designated side and tighten the setscrews.

Install Base Grille

There are two pieces to the base grille to allow for a custom fit: the base grille itself and the skirt. The skirt can be added to the base grille in order to extend it all the way to the floor.

- To see whether the skirt is needed, place the base grille into position. Do not attach the base grille to the refrigerator. Measure the distance between the bottom of the base grille and the floor. The gap must be a minimum of 1/2" (1.27 cm) in order to add the skirt.
NOTE: If the gap measures less than 1/2" (1.27 cm), skip steps 3 and 4 of the instructions, and install the base grille only.
- Remove the film from the base grille.
- Snap the skirt onto the base grille.

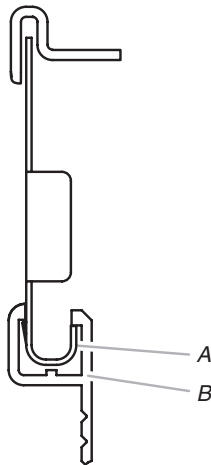

A. Base grille
 B. Skirt

- Trim the skirt by scoring the proper "V" groove with a utility knife. Break the skirt at the score line.

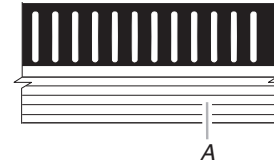

A. "V" groove

- Using the two screws, attach the base grille assembly to the refrigerator as shown.

NOTE: Drive in the right side screw first.

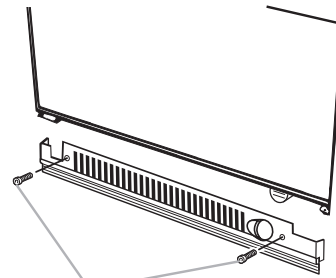

A. Screws (2)

Complete Installation

- Turn the water supply line valve to the "Open" position.
- Turn the refrigerator switch to the ON position. See "Power On/Off Switch" in the Use & Care Guide for instructions. Wait a few minutes. Check the water line connections for leaks.
- Remove all boxes, parts packages and packing materials from the interior of the refrigerator. See the "Cleaning" section in the Use & Care Guide for instructions. Remove the film and cardboard from the grille and doors or door frame, depending on your model.
- Install the shelves and bins in the refrigerator and freezer compartments.
- The controls are preset at the factory to the midpoint setting. Check that the compressor is operating properly and that all the lights are working.
- Flush the water system before use. See "Water System Preparation."

To get the most efficient use from your new built-in refrigerator, read the Use & Care Guide. Keep Installation Instructions and Use & Care Guide near the built-in refrigerator for easy reference.

PRODUCT OPERATION

THEORY OF OPERATION

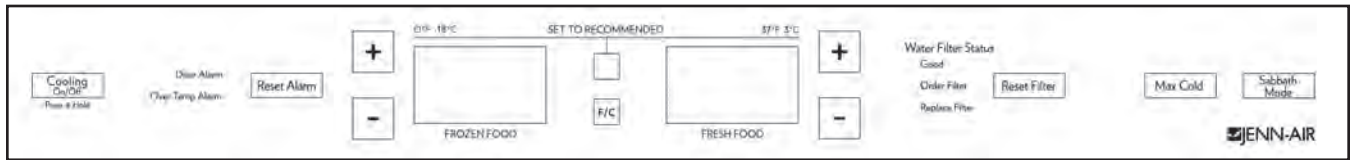

THE ELECTRONIC CONTROL PANEL

⚠ WARNING

Electrical Shock Hazard

Disconnect power before servicing.

Replace all parts and panels before operating.

Failure to do so can result in death or electrical shock.

OVERVIEW

The refrigerator Constant Flow Temperature Management System uses two thermistors to monitor temperature changes inside the refrigerator and freezer compartments. Two electronic control boards are used in the refrigerator: a main electronic control board, and a low voltage (Storage bin) board. The main electronic control board manages the operation of the variable capacity compressor (VCC), a variable speed evaporator fan motor, and a variable position air door. The air door allows independent temperature control of the refrigerator and freezer compartments.

The main electronic control board seeks the most efficient means possible to maintain temperatures as it controls the operation and speed of the compressor and the evaporator fan motor. Higher fan speed is used before increasing the compressor speed to minimize power consumption. A nearly constant run

time is sought at the lowest possible fan and compressor speed.

Freezer temperatures can be set from 5°F to -5°F (-15°C to -21°C). Refrigerator temperatures can be set from 45°F to 33°F, (7°C to 1°C).

The Adaptive Defrost Control (ADC) portion of the main electronic control board utilizes “pulsed defrost” technology to perform the defrost function (see page 3-4).

Note: This information is written specifically for the 42" French Door model but applies to Bottom Mount and SXS models with these exceptions. 42" and 48" SXS models and 36" Bottom Mount models have only one Deli Pan, the 42" FD model has two. The SXS air circulation is slightly different.

The main electronic control board monitors the water valve for total elapsed time and gallons of water used. The number displayed on the Water Filter Indicator (WFI) is the percentage of filter usage remaining.

The numeric display can be set for Fahrenheit or Celsius and displays the actual temperatures. The display range for the refrigerator is from 27°F to 70°F (-2.8°C to 21°C). The normal freezer display range is from -10°F to 70°F (-23°C to 21°C). Temperatures above or below these limits will be displayed at the corresponding temperature limit. During Max Cool, the freezer display will read -5°F (-21°C), and the refrigerator will read 34°F (1°C).

The display will show the temperature setting any time the actual temperature is within ±6°F

of the customer setting. This will avoid concern over temperature fluctuations when the doors are opened. The customer setting will also be displayed during the defrost period, and 30 minutes after defrost. Press the temperature adjustment key to view the current temperature setting, or to change the setting. When the temperature adjustment key is used to change the temperature setting, the display will brighten for 5 seconds.

Available features include:

- Water Filter Indicator
- Max Cool
- Over-Temperature Alarm
- Holiday Mode
- Energy Saver Mode

TEMPERATURE CONTROL

The main electronic control board checks the resistance of the thermistors, and compares it to both the customer temperature settings and the last thermistor reading taken. This information is used to determine when to begin a cooling operation, and if a change is necessary in the damper setting, or the evaporator fan or compressor speed.

When a warm refrigerator is first put into a cooling mode, the air door partially opens, and the compressor and evaporator fan motors start to run at maximum rpm. The air door will gradually move to its fully open position.

As the actual temperature in the refrigerator nears the selected temperature setting, the electronic control compares the temperatures in both compartments. The compartment that has the greatest need for cooling will control the speed of the evaporator fan motor.

Freezer Temperature Control — Temperature Increasing

When the freezer calls for cooling, the compressor begins to run at minimum rpm, (see the chart on page 3-3), and the evaporator fan begins to run at 2000 rpm. The compressor and evaporator speeds are continuously updated. Speed changes are made based on:

- The difference between the actual temperature and the selected temperature settings.
- The rate of temperature change.

If the temperature increases 4°F above the selected temperature setting, the evaporator fan speed begins to gradually increase. The evaporator fan motor reaches the maximum speed of 3000 rpm at 5°F above the selected temperature setting, and the compressor speed begins to gradually increase. A maximum compressor speed of 4500 rpm will be reached at 9°F above the selected temperature setting.

Freezer Temperature Control — Temperature Decreasing

When the freezer temperature begins to decrease, the process will reverse. The compressor speed decreases, followed by the evaporator fan speed.

Refrigerator Temperature Control — Temperature Increasing

When the refrigerator calls for cooling while the freezer is satisfied, the air door begins to open, and the evaporator fan starts to run at minimum speed. If the temperature continues to rise, the air door will continue to open. If the temperature continues to rise after the air door is fully open, the evaporator fan speed will gradually increase to a maximum of 3000 rpm. If the temperature continues to rise, the compressor starts to run, or if it has already been running, begins to increase in speed.

Refrigerator Temperature Control — Temperature Decreasing

As the refrigerator temperature approaches the selected setting, the control compares the temperatures in both compartments to determine which compartment will control the fan speed. If the freezer is further from the selected temperature setting, it controls the fan speed, and the air door begins to close, thus reducing the airflow to the refrigerator.

If the freezer is satisfied, the air door remains open, and the fan speed begins to decrease. When the selected temperature setting is reached, the air door closes.

COMPRESSOR

The main control board supplies a 5 vdc, peak-to-peak square wave, at 54 to 150 Hz, to the inverter board. A standard VOM will read approximately 2.5 vdc. The inverter board supplies the variable capacity compressor with three-phase 230 vac. Varying the voltage and frequency to the inverter board changes the speed of the compressor. The compressor can run at speeds of 1620 to 4500 rpm.

NOTE: It is not necessary, nor is it recommended, to test the output of the inverter board.

While the compressor is running, its speed is continuously updated. Speed is determined after analyzing two factors:

- The difference between the actual temperature and the selected temperature settings.
- The rate of temperature change.

Minimum compressor speed is based on the freezer's selected temperature setting, as shown in the following chart.

Freezer Temperature Setting (°F)	Compressor Minimum Speed
6 to -2	1620 rpm
-3	1800 rpm
-4	2000 rpm
-5	2200 rpm

The compressor generally cycles on and off according to the cut-in and cut-out temperatures of the freezer, however, the refrigerator can turn on the compressor if the evaporator fan is at maximum speed and the refrigerator temperatures are not dropping.

COMPRESSOR PROTECTION

To protect the compressor and maintain efficiency, minimum compressor off time is programmed into the main control board. When the compressor turns off, a minimum of 7 minutes must elapse before allowing a restart.

At the end of the 7-minute period, the condenser fan motor starts, and the main control board sends the compressor speed signal to the inverter. The inverter utilizes a current-limiting device and thermal protection that eliminates the need for a compressor-mounted thermal protector.

EVAPORATOR FAN MOTOR

The evaporator fan motor is a 12 vdc, variable speed motor. The motor has four wires:

- A blue wire that is not used.
- A red wire provides a constant 12 vdc.
- A yellow wire provides a variable voltage of between 5 vdc and 17 vdc to control the motor speed from 2000 to 3000 rpm.
- A white wire provides a common return.

EVAPORATOR FAN & AIR DOOR DELAY

After defrost, an evaporator fan delay avoids unnecessary movement of warm, moist air through the refrigerator by chilling the evaporator prior to starting the fan. Immediately after defrost drip time, the compressor starts at 4500 rpm, but the evaporator fan is delayed for 2 minutes.

AIR DOOR

The air door is driven by a reversible DC stepper motor. The motor operates on a 12 vdc, peak-to-peak square wave. Voltage is delivered to the air door in a series of short pulses. It is not possible to obtain a reliable voltage reading with a VOM.

Separate windings are used to move the air door open or closed. The door can be in any position from 0 to 90 degrees. The air door is used to fine-tune the airflow to the refrigerator.

The refrigerator temperature determines the opening of the air door. When the refrigerator requires cooling, the air door partially opens, and then adjusts, if necessary. While the refrigerator is cooling, the door will be adjusting continuously to maintain or recover refrigerator temperature.

ADAPTIVE DEFROST

The adaptive defrost control function of the main electronic control board allows the refrigerator to enter a defrost mode only when it is needed. When powered up for the first time, the control initiates a defrost cycle after 8 hours of compressor run time. By monitoring the duration of defrost heating time and compressor run time, the control will continuously adapt the time between defrosts to optimize efficiency. Time between defrost periods will vary between 8 and 100+ hours.

Defrost will occur immediately when the compressor has run at 3990 rpm or greater for 1 hour, and 8 hours have elapsed since the last defrost.

PULSED DEFROST

For the first 2 minutes of defrost, the heater is on continuously. It will then cycle off for 1 minute, and back on for 2 minutes. The heater will continue to cycle at this ratio until the bimetal opens, or until 33 minutes has elapsed. At this point, heat is discontinued, and a 4-minute "drip time" begins. This allows the water to drain before the refrigerator returns to a cooling mode. Maximum defrost time, (pulsed heat on/off time + drip time) is 37 minutes.

When entering a defrost cycle, if the bimetal is open, the time to defrost is reset to 8 hours, and the control will time through the entire 37-minute defrost period. The time to defrost can be reset to 8 hours manually by holding "set to recommended" for 5 seconds. During diagnostics this will allow a technician time to look for heater operation, and if necessary, bypass the bimetal.

POWER INTERRUPTION

After a power interruption, the following events will occur:

- The refrigerator returns to the same operating mode and settings in use prior to the power interruption. If the unit was off, it remains off.
- Initially, the compressor, evaporator fan, and condenser fan motors will be off.
- The air door will close, and then adjust to the proper opening. The evaporator fan starts when the air door opens.
- The adaptive defrost control resets the compressor run time counter to 0, and if the freezer is above 20°F, the time to defrost is set to 8 hours.
- If the freezer temperature is below 14°F (-10° C), the compressor may start after a delay of 7 minutes. If the freezer temperature is above 14°F, the compressor starts immediately.
- The Main Control Board board supplies 14 volts DC to the mullion heater when both refrigerator doors are closed, Energy Saver mode is turned off, and Holiday mode is turned off.

FAILURE DEFAULTS

In the event of a thermistor, or keypad failure, the main electronic control board uses one of the following default modes, which will continue until the failure is corrected.

Refrigerator Thermistor

If the main electronic control board senses an open or a shorted thermistor, the air door and the evaporator fan motor will begin to operate on a timed on and off cycle, based on current selected temperature settings. The evaporator fan motor will run when the air door is open.

At mid-settings of 37°F / 3°C, the air door will open for 16 minutes, and close for 30 minutes. Setting the freezer colder, or the refrigerator warmer, will reduce the door-open time. Setting the freezer warmer, or the refrigerator colder,

Freezer Thermistor

If the main electronic control board senses an open or a shorted thermistor, the compressor and the evaporator fan motor will begin to operate on a timed on and off cycle. The cycle time is based on current selected temperature settings.

At mid-settings of 37°F / 3°C, the compressor and the evaporator fan motors will run for 35 minutes, and be off for 25 minutes. Setting the freezer colder will increase the run time. Setting the freezer warmer will decrease the run time.

The compressor will run at minimum speed. The evaporator fan will also run at minimum speed, unless the refrigerator compartment requests a higher speed.

Keypad

If the main electronic control board detects that the keypad is not working, it reverts to the default temperature settings of 37°F (3°C) in the refrigerator, and 0°F (−18°C) in the freezer.

Evaporator Fan Motor

If the evaporator fan motor malfunctions, the compressor may run at 4500 rpm for an indefinite period, except during the defrost periods.

MAX COOL MODE

Max Cool changes the refrigerator temperature setting to 34°F (1°C) and the freezer to −5°F (−21°C) for 24 hours. During Max Cool, the freezer and refrigerator temperature displays show the new temperature settings, not the actual temperatures.

In most cases the motors run 100% for more than 1 hour. The control returns to the previous user setting after 24 hours, or any time the temperature settings are changed.

AUTOMATIC MAX ICE

Automatic Max Ice operates any time the ice maker water valve is energized. The duration of Automatic Max Ice is 1-1/2 hours. During Automatic Max Ice the following occurs:

- The freezer display shows the user temperature settings and not the actual temperature.
- The freezer temperature setting changes to −5°F (−21°C).
- The evaporator fan runs at 3000 rpm.
- The compressor runs the entire 1-1/2 hour mode. Speed is determined by the difference between actual freezer temperature and −5°F (−21°C).

HOLIDAY MODE

The Holiday Mode may be used for the following occasions:

- On vacation.
- Religious observance (Sabbath Mode).
- When the Holiday Mode is selected, the corresponding backlit blue LED flashes for 5 seconds, and then remains on, to indicate that the feature is activated.

In the Holiday Mode the following occurs:

- Temperature selections remain at the current setting, but are not displayed.
- The Water Filter Indicator is not displayed, but monitoring continues.
- The alarms are disabled.
- The ice maker is disabled.
- The interior lights are disabled.
- The temperature displays and all of the LEDs will be off, except for the Holiday Mode and Cooling On/Off LEDs. The Holiday Mode and Cooling On/Off LEDs will illuminate regardless of the door position.
- Keypad operation is disabled, with the exception of the Holiday Mode key, or the Power On/Off key.

The Holiday Mode will be cancelled when the following occurs:

- Pressing the Power On/Off, or Holiday Mode keypads.

When the Holiday Mode is cancelled, the Holiday Mode LED turns off, and the control reverts to the settings in use prior to activation. All inactive devices are restored, and the Water Filter Indicator is updated.

The Adaptive Defrost Control function continues during the Holiday Mode, but the control will defrost at a fixed 12-hour interval.

OVER TEMPERATURE ALARM

The Over Temperature Alarm sounds, and the indicator light flashes when either the refrigerator temperature exceeds 48°F (9°C), or the freezer temperature exceeds 15°F (–9°C) for over 1-1/2 hours. The overtemperature alarm will not occur when the unit is cooling down. The appropriate temperature display flashes to show the user which compartment is effected. The alarm stops if the temperature(s) returns to normal, but the red Over Temperature LED will continue to flash (refer to “Master Alarm Reset”

to reset the Over Temperature Alarm).

MASTER ALARM RESET

Pressing the Over Temperature Reset will turn off the audio alarm, but does not affect the indicator light the first time the Over Temperature Reset is pressed. The indicator light will turn off once the Over Temperature Reset is pressed a second time. The audio alarm will not sound again for the current condition that caused the alarm until a new condition occurs.

A Master Alarm Reset can be performed by turning the power to the refrigerator off and on again. The indicator light will turn on again after the Over Temperature Reset is pressed, if the condition that caused the alarm is still present.

DOOR OPEN ALARM

If any door is left open for more than 10 minutes, the interior lights will be disabled, the Door Open icon will flash, and the alarm will sound. If the door is closed during the alarm operation, the alarm will reset.

SALES DEMONSTRATION MODE

This mode provides a sequential display of the temperature displays and feature LEDs. To enter the Demonstration Mode, press and hold the Max Cool and Power On/Off keys for 2 seconds. If the refrigerator or freezer door is open for 10 minutes, the interior lights will turn off.

LOW VOLTAGE STORAGE BIN CONTROL BOARD

There are two storage bin control boards on Bottom Mount Models and only one on SXS. storage bin boards get 14 VDC power from the Main Control Board board.

The Storage bin control provides the following functions:

- Communicate with one ingredient care center pan each.
- Each provides 14 volts DC to an ingredient care center pan to operate the LED lighting and keypad.
- Controls the operation of the motorized air baffle for each ingredient care center pan.

The controls communicate and work together to provide proper function. The Storage bin control operates the ingredient care center pan LED lighting but it does not get direct input on the position of the refrigerator door switches. In order to operate the LED pan lighting at the proper time, the main control monitors the refrigerator door switches and sends a communication on the data line to let the Storage bin control know when a refrigerator door is opened.

Ingredient Care Center Temperature Control



of the evaporator fan motor. The Storage bin control also sends a 12 vdc, peak to peak square wave to the ingredient care center air door to open the door.

The ingredient care center air door will be in one of five possible positions based on the ingredient care center user setting.

The air door will close at any setting when the proper temperature has been reached. Here are the four possible positions and temperatures for each setting.

- Closed.
 - When the refrigerator compartment is calling for cooling and the freezer is satisfied. This allows the refrigerator to cool faster.
 - Any setting when proper pan temperature has been achieved.
 - When the refrigerator is in holiday mode.
 - When the refrigerator is in defrost mode.
- Deli—40°F, open at a 10° angle.
- Produce—39°F, open at a 20° angle.
- Meats—33°F, open at a 30° angle.
- Quick Chill—25°F, open at a 45° angle.

When Quick Chill is selected, the pan temperature is set to 25°F, and the freezer temperature is set to -5°F, for one hour. The evaporator fan motor operates and runs at high speed until the set temperature is reached. When the hour has timed out, the ingredient care center user interface and the freezer temperature both return to the previous customer settings.

Note: The temperatures listed are representative of what the software program is set to achieve. Ambient conditions, food loads and usage will affect actual temperature.

AIR CIRCULATION

36" Integrated Design Bottom Mount Refrigerator Cabinet Air Flow Schematic

In order to ensure proper temperatures, you need to permit airflow between the refrigerator and freezer sections. As shown in the illustration, cool air enters the freezer section through vents in the rear and top. The air flows forward through the freezer section and recirculates under the freezer floor. Cool air enters the refrigerator section through the top, flows down and across shelves to the doors and recirculates to return air vents at the bottom.

It is important not to block any of the vents with food items. If the vents are blocked, airflow will be restricted, and the temperature management system will not function properly.

IMPORTANT: Because air circulates between both sections, any odors formed in one section will transfer to the other. Keep both sections clean, and wrap or cover foods tightly to help avoid the transfer of odors from food to ice.

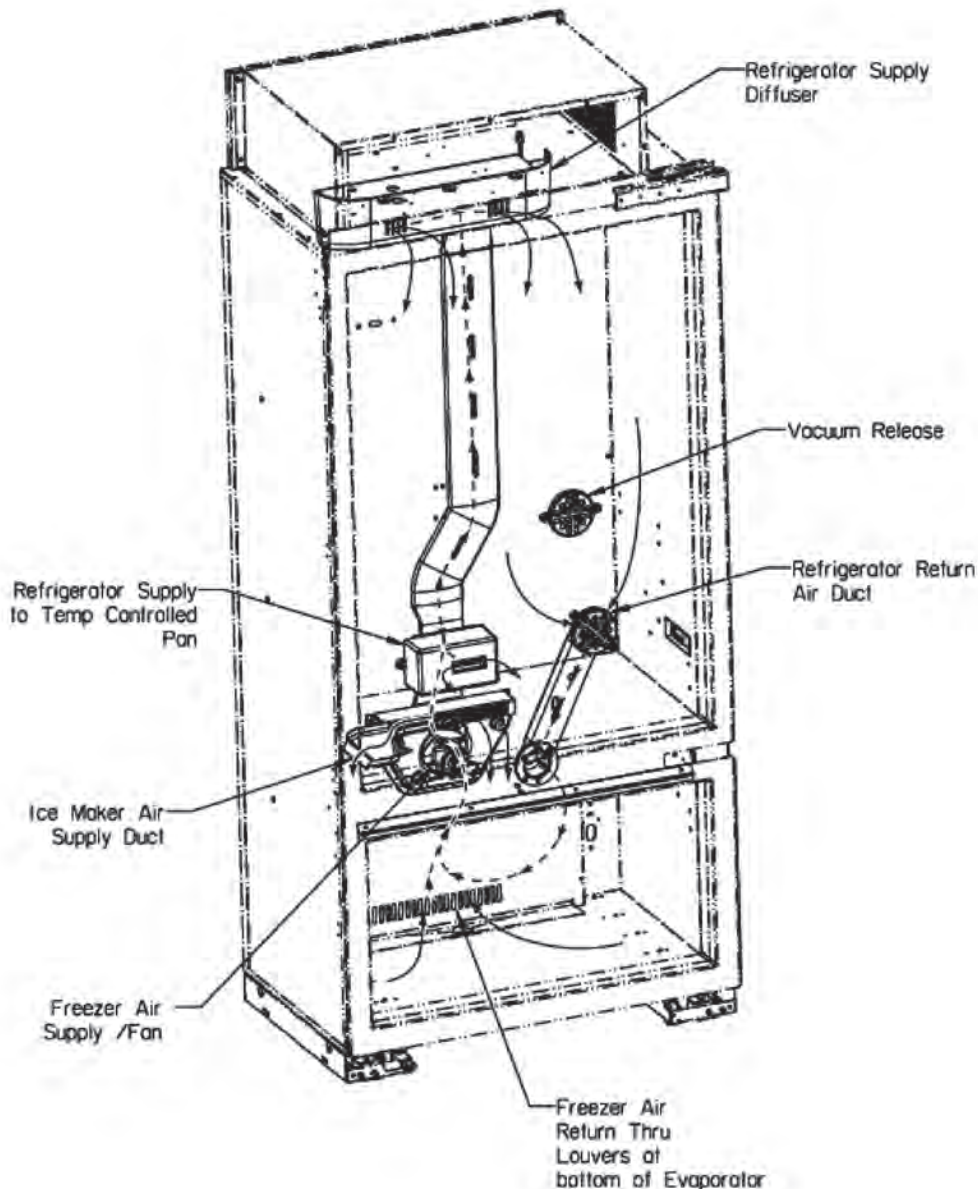

AIR CIRCULATION (continued)

42" Integrated Design French Door Bottom Mount Refrigerator Cabinet Air Flow Schematic

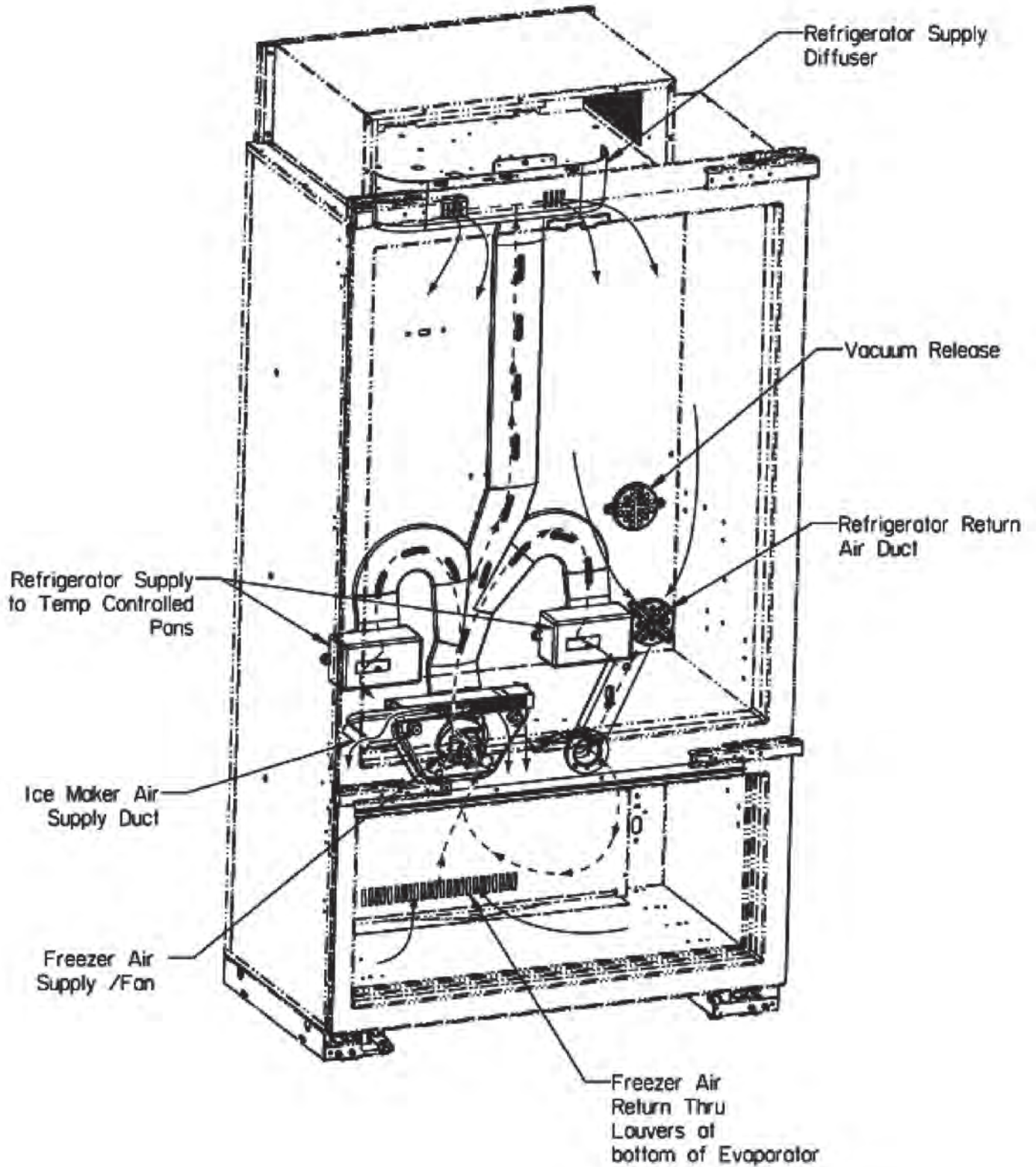

AIR CIRCULATION (continued)

42" and 48" Integrated SXS Cabinet Air Flow Schematic

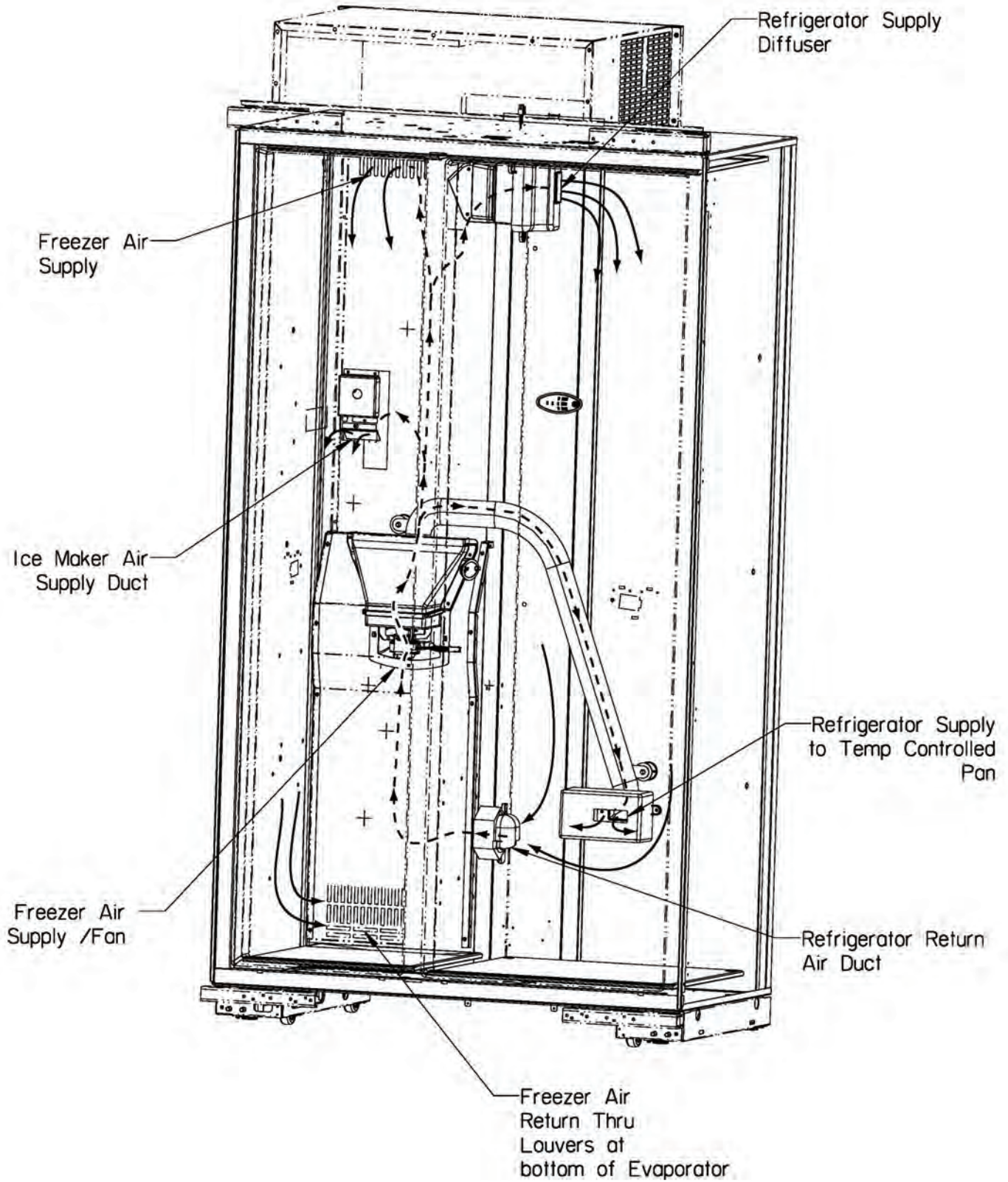

Meat Storage Guide

Store most meat in original wrapping as long as it is airtight and moisture-proof. Rewrap if necessary. When storing meat longer than the times shown below, freeze the meat.

Fresh fish or shellfish: Use same day as purchased.

Chicken, ground beef, variety meat (liver, etc.): 1-2 days.

Cold cuts, steaks & roasts: 3-5 days.

Cured meats: 7-10 days.

Leftovers: Cover leftovers with plastic wrap, aluminum foil, or plastic containers with tight lids.

Quick Chill Setting

Each deli pan has a Quick Chill setting. Activating this selection lowers the temperature of the pan for a period of one hour.

NOTE: This will lower the deli pan temperature below the freezing point for liquids.

— NOTES —

COMPONENT ACCESS

This section instructs you on how to service components inside the Built-In French Door Bottom-Mount Refrigerator. The components and their locations are shown below.

COMPONENT LOCATIONS



⚠ WARNING

Electrical Shock Hazard

Disconnect power before servicing.

Replace all parts and panels before operating.

Failure to do so can result in death or electrical shock.

Unit Compartment Components

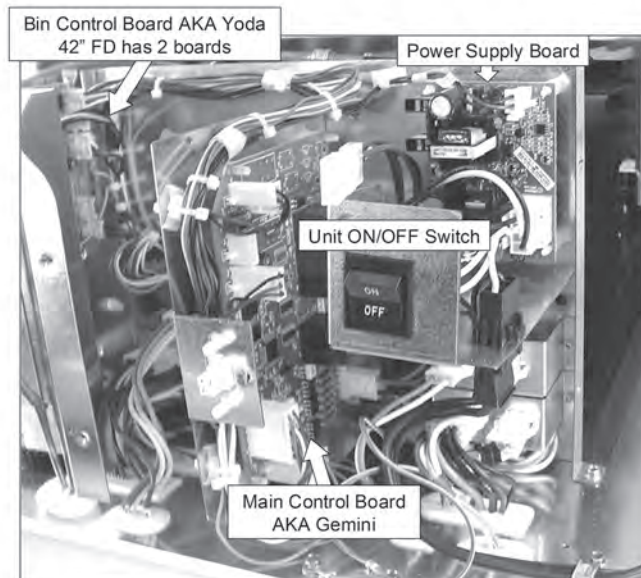

42" and 48" Jenn-Air SxS

Articulated Hinges

Articulated hinges are needed to achieve the close tolerances when this unit is built in flush with adjoining cabinets. The wider hinge is the top hinge and the narrow hinge is the bottom hinge, see figure 1.

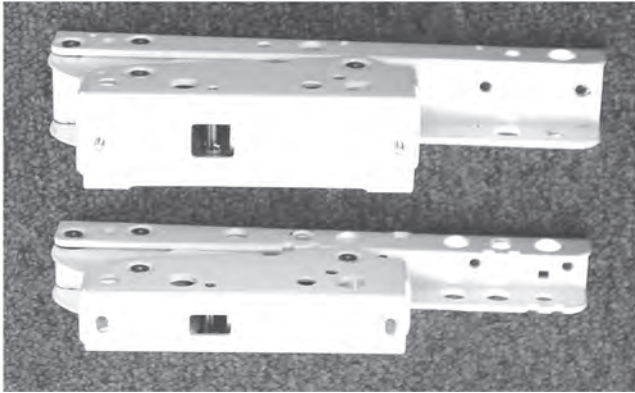

Figure 1

Lower Hinge – No Panel

Screws secure the lower hinge to the bottom of the cabinet, see figure 2. The hinges incorporate very strong springs, keep hands away from the pinch area when the hinge is extended, see figure 3. The inner door panels are attached to the hinges and Stainless steel panels or wood overlays are attached to the inner panels. Stainless steel panels or wood overlays attach to the hinges.



Figure 2

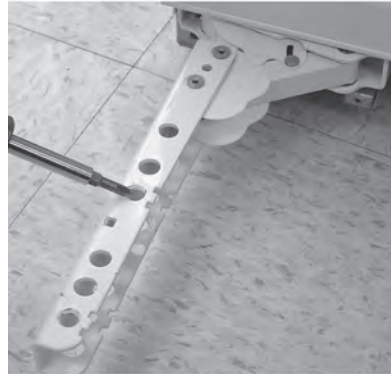

Figure 3

Adjusting Inner Door Panel and Hinge Gap

Two adjustable pins are used to attach the hinges to the inner door panel, see figure 4. To adjust inner door panel or inner door panel to hinge gap, remove two Torx cap screws, see figure 5.

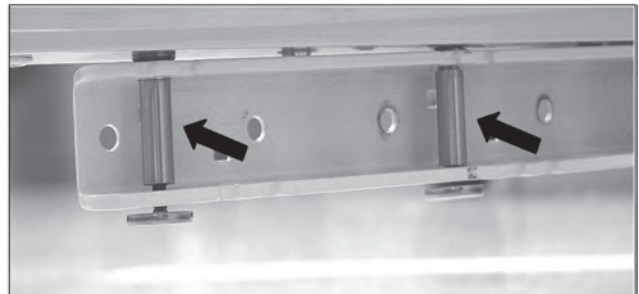

Figure 4

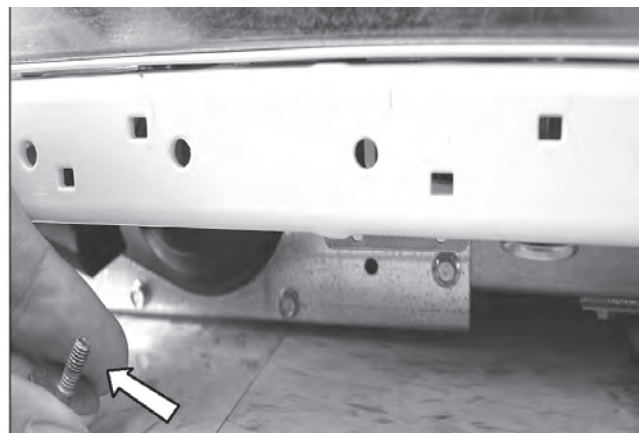

Figure 5

42" and 48" Jenn-Air SxS (continued)

Top Door Hinge Adjustment

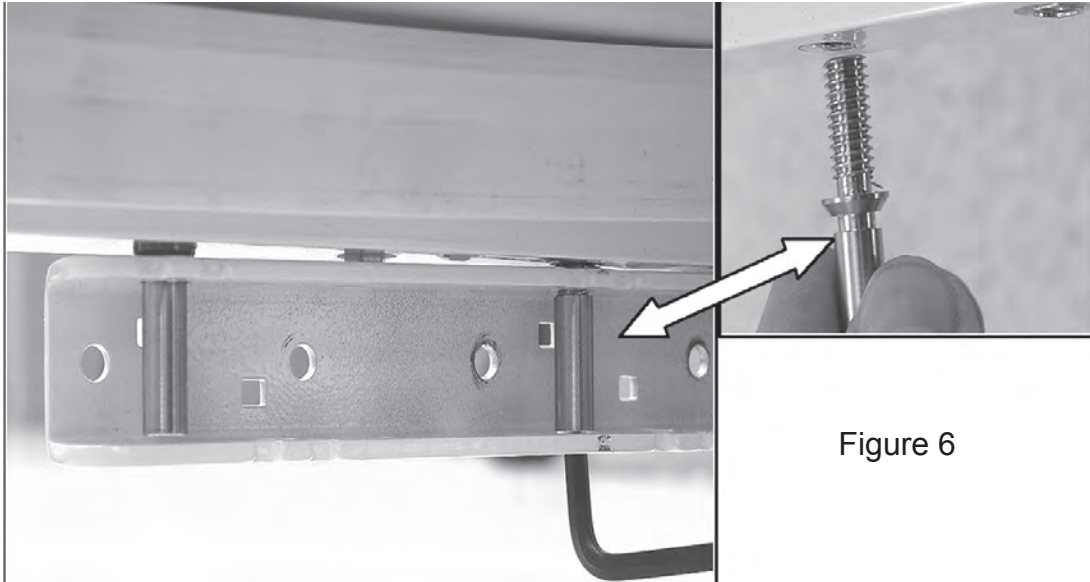

Figure 6

To adjust begin by loosening the two adjustable pins on the top hinge to allow the inner panel to move. Adjust the lower pins to raise or lower the inner door panel or close the gap between the hinge and inner door as needed, see figure 6. After making adjustments, tighten the top adjustment pins and replace the cap screws.

Top Door Hinge Planetary Adjustment

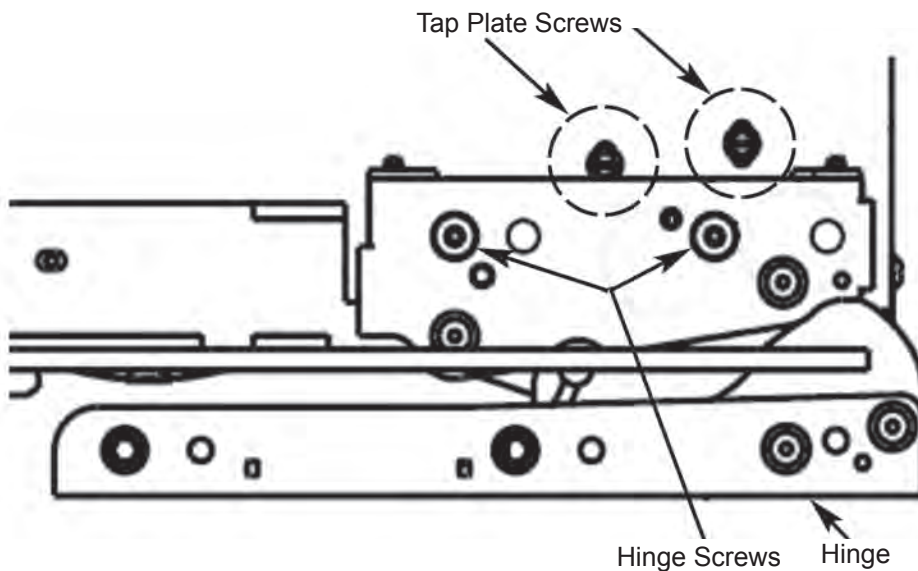

Figure 7

Loosen the tap plate screws, see figure 7.

DO NOT REMOVE these screws, only loosen. If these screws are removed, they will drop into the hinge cup and will take some time to fish out. Loosen the hinge screws, see figure 7.

Adjust the door in or out as needed. Tighten the four hinge screws and the tap plate screws.

There is approximately 3-4mm of adjustment in the top hinge.

42" and 48" Jenn-Air SxS (continued)

Refrigerator Door Switches and Lights

⚠ WARNING



Electrical Shock Hazard
Disconnect power before servicing.
Replace all parts and panels before operating.
Failure to do so can result in death or electrical shock.

A new light switch design is used on this product. The left and right door switches are actuated by a pad inserted into the hinge, see figure 1.

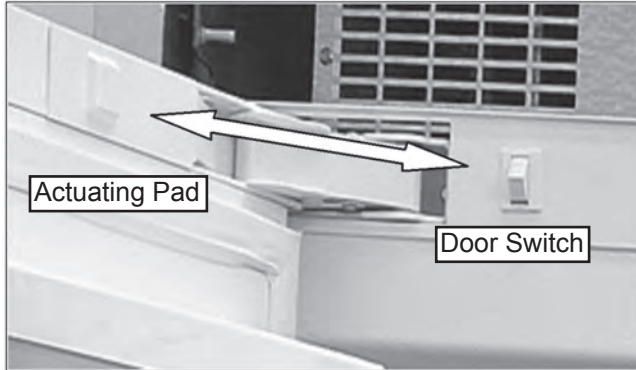

Figure 1

Figure 2 depicts the actuating pad depressing the door switch. The door switches are enclosed in a metal shield. The shield should always be replaced after servicing.

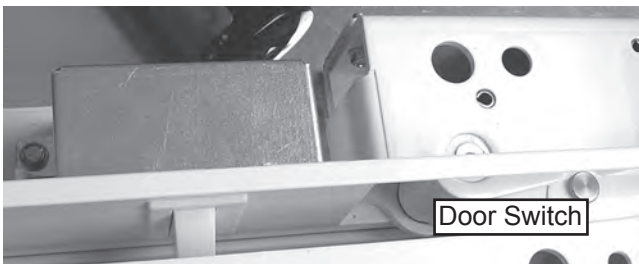

Figure 2

The RC lights are secured to the cabinet with 1/4" Hex head screws, see figure 3.



Figure 3

Remove the screws and drop down the screw end of the socket to unhook the opposite side lip from the cabinet, see figure 4.

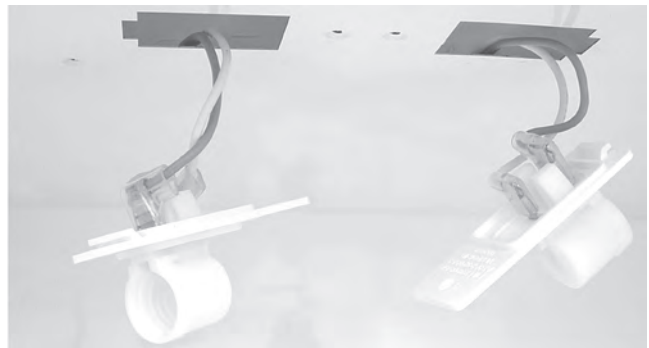

Figure 4

42" and 48" Jenn-Air SxS (continued)

Ice Maker

⚠ WARNING



Electrical Shock Hazard
Disconnect power before servicing.
Replace all parts and panels before operating.
Failure to do so can result in death or electrical shock.

This unit uses a conventional 8 Cavity Modular Ice maker, see figure 1.



Figure 1

Remove the three 1/4" Hex head screws securing the ice maker to the cabinet wall and disconnect the wiring harness, see figure 2.



Figure 2

A heat shield is secured to the ice maker mold with three 1/4" Hex head screws, see figure 3. Always replace the heat shield after servicing



Figure 3

Figure 4 depicts the core ice maker

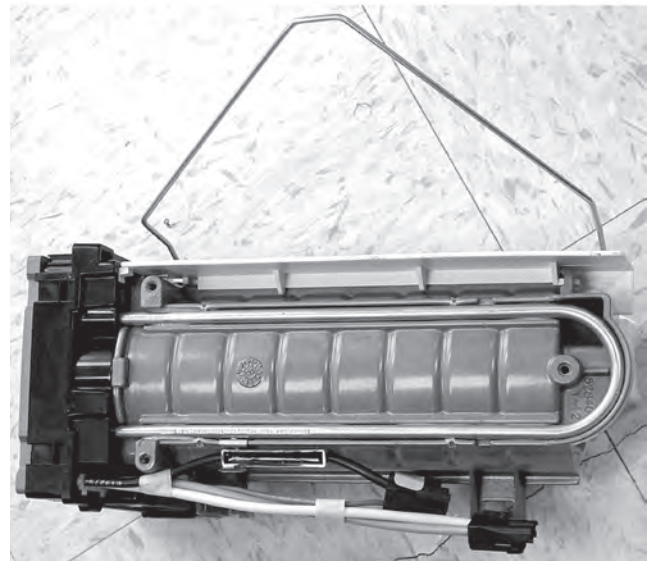



Figure 4

42" and 48" Jenn-Air SxS (continued)

Modular Ice Maker

WARNING



Electrical Shock Hazard

Disconnect power before servicing.

Replace all parts and panels before operating.

Failure to do so can result in death or electrical shock.

The ice maker can be checked like any other 8 cavity modular ice maker. Test points are identified inside the cover of the ice maker, see figure 1.

**(FOR TECHNICIAN USE ONLY/
RÉSERVÉ À L'USAGE DES TECHNICIENS)**

- Refer to tech sheet in unit compartment for component checks.
- Ejector blades at "rest" in two o'clock position.
- Do not manually rotate ejector blades.

- Consulter la fiche technique située dans le compartiment de l'appareil, pour les contrôles sur les composants.
- Lames d'éjection à la position de repos, à la position horaire « 2 h ».
- Ne pas faire tourner les lames d'éjection à la main.

TEST POINT/ POINT DE TEST	COMPONENT/ COMPOSANT	
V	WATER VALVE/ROBINET DE PRISE D'EAU	
L	LINE VOLTAGE/TENSION	
T	THERMOSTAT/THERMOSTAT	
H	MOLD HEATER/CHAUFFAGE DU MOULE	
M	MOTOR/MOTEUR	
N	NEUTRAL/NEUTRE	

Manufactured under one or more of the following United States Letters Patent/
Produit protégé par un ou plusieurs des brevets suivants délivrés aux États-Unis

4,649,712	4,665,708	4,787,216
4,649,717	4,728,759	4,799,362
4,649,718	4,756,165	4,833,894
4,659,157	4,767,896	

other patents pending/Autres brevets demandés

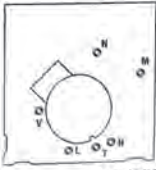

2307955

Figure 1

Inlet Water Tube Heater

Remove three screws securing the cover to the cabinet wall, see figure 2.



Figure 2

The inlet water tube heater slides onto the fill tube. Disconnect the wiring harness to remove the heater, see figure 3..



Figure 3

42" and 48" Jenn-Air SxS (continued)

Accessing Evaporator and Related Components

⚠ WARNING



Electrical Shock Hazard
Disconnect power before servicing.
Replace all parts and panels before operating.
Failure to do so can result in death or electrical shock.

Remove all bins and shelving, see figure 1



Figure 1

Remove 2 screws that secure the bin spacer/slide assemblies to the cabinet wall, see figure 2.



Figure 2

Remove the 2 shelf studs and 2 rail/slide assemblies from the right side of the cabinet and the light cover from the left side of the cabinet, see figure 3.



Figure 3

42" and 48" Jenn-Air SxS (continued)

Accessing Evaporator and Related Components

⚠ WARNING



Electrical Shock Hazard
Disconnect power before servicing.
Replace all parts and panels before operating.
Failure to do so can result in death or electrical shock.

Remove the evaporator cover screws and remove cover. With the cover removed, the defrost components are accessible, see figure 1

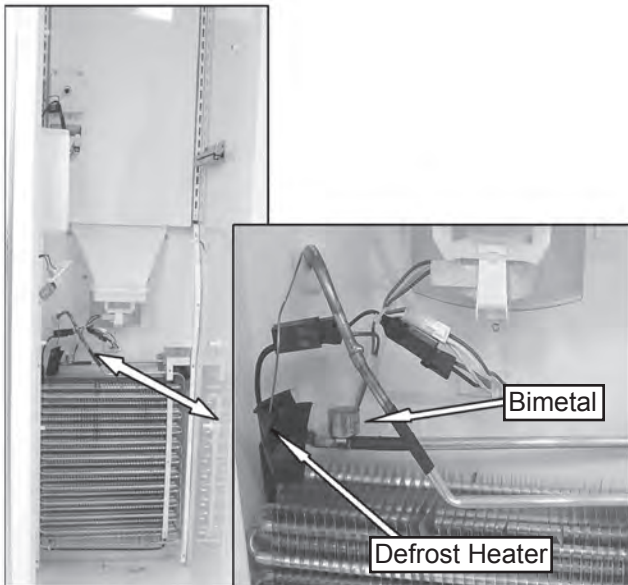

Figure 1

Remove 4 screws and drop down the evaporator fan and duct assembly, see figure 2.

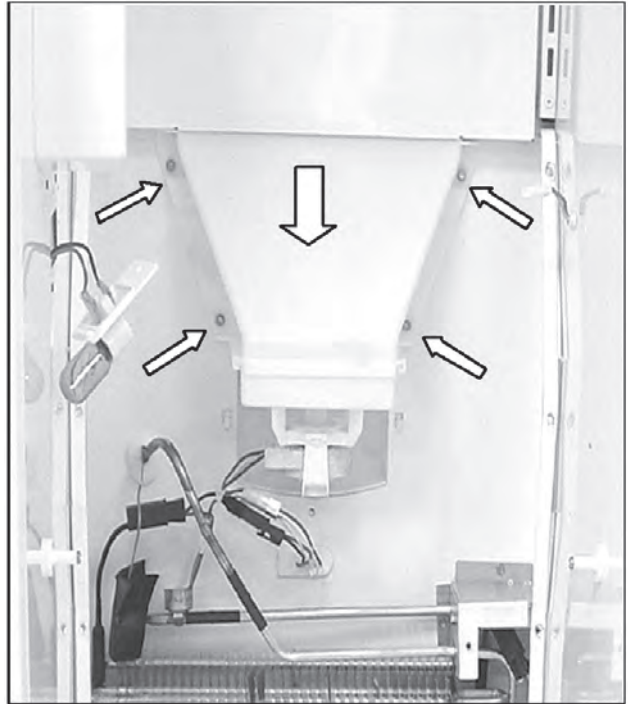

Figure 2

The fan assembly slides out of the duct, see figure 3.

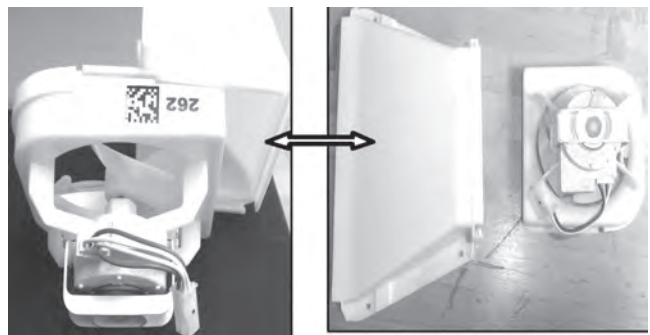

Figure 3

42" and 48" Jenn-Air SxS (continued)

Accessing Defrost Heater

⚠ WARNING



Electrical Shock Hazard

Disconnect power before servicing.

Replace all parts and panels before operating.

Failure to do so can result in death or electrical shock.

Remove 2 screws securing the bracket to the top right hand corner of the evaporator, see figure 1

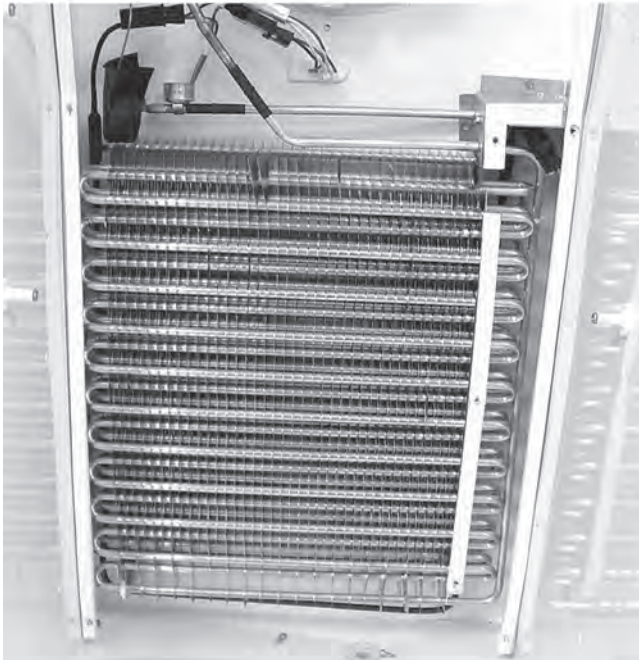

Figure 1

Remove the evaporator form the back wall of the cabinet. Make sure not to crimp the suction line, see figure 2.



Figure 2

Disconnect the defrost heater wiring harness. Snap the defrost heater out of the mounting brackets and slide the heater out of the bottom of the evaporator to remove. See figure 3.

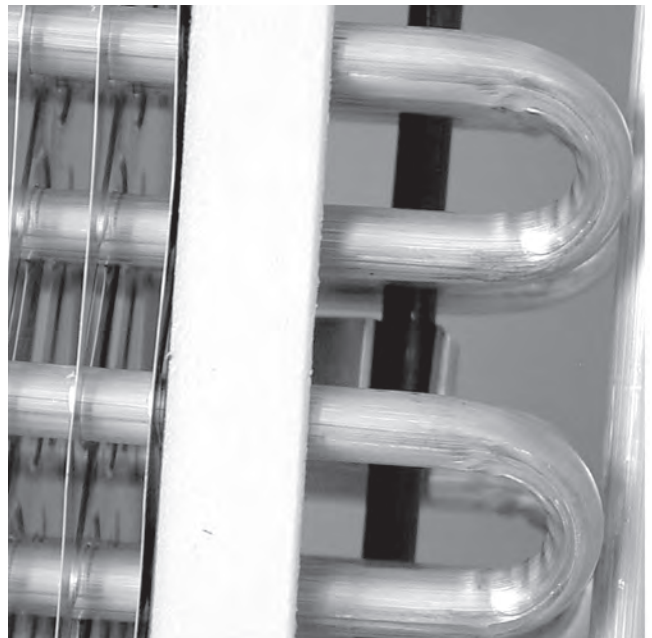



Figure 3

42" and 48" Jenn-Air SxS (continued)

Accessing air damper

! WARNING



Electrical Shock Hazard
Disconnect power before servicing.
Replace all parts and panels before operating.
Failure to do so can result in death or electrical shock.

1. Unplug refrigerator or disconnect power.
2. Remove 2 screws securing the cover to the cabinet, see figure 1. Remove cover to expose foam diverter block, see figure 2.



Figure 1



Figure 2

3. Remove block. Inspect seal area before reinstalling, see figure 3.
4. Remove the air damper and disconnect the wiring harness, see figure 4.

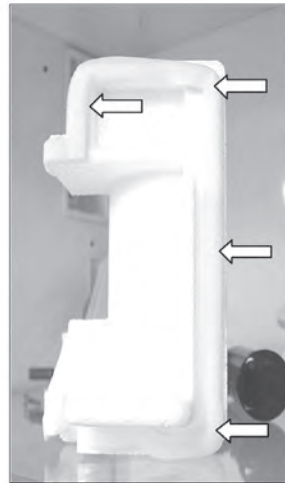
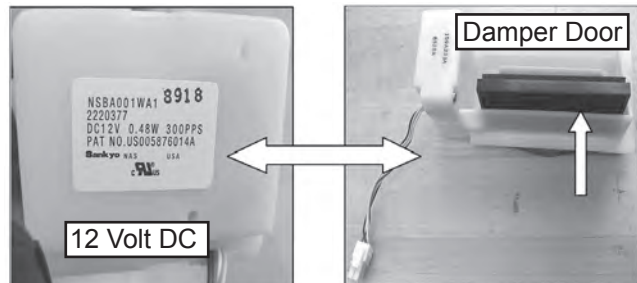

Figure 3

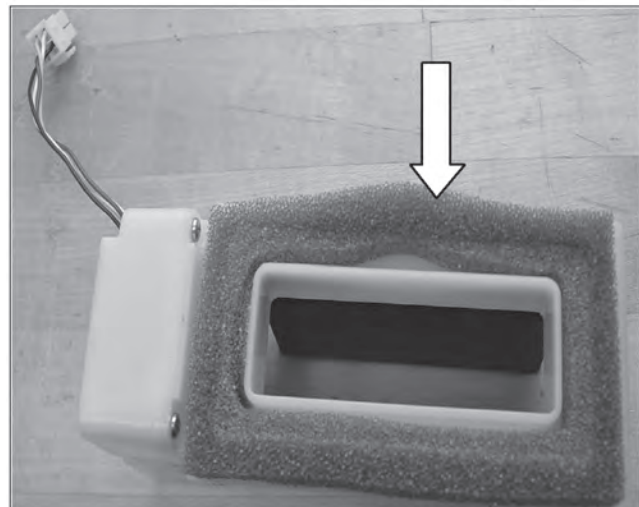

Figure 4

Damper Assembly



The damper motor is operated by 12 volt DC. Inspect the seal on the damper door and the perimeter of the duct.



42" and 48" Jenn-Air SxS (continued)

Back Panel

⚠ WARNING



Electrical Shock Hazard

Disconnect power before servicing.

Replace all parts and panels before operating.

Failure to do so can result in death or electrical shock.

1. Unplug refrigerator or disconnect power.
2. Remove 2 screws and lift out the rear access panel, see figure 1.

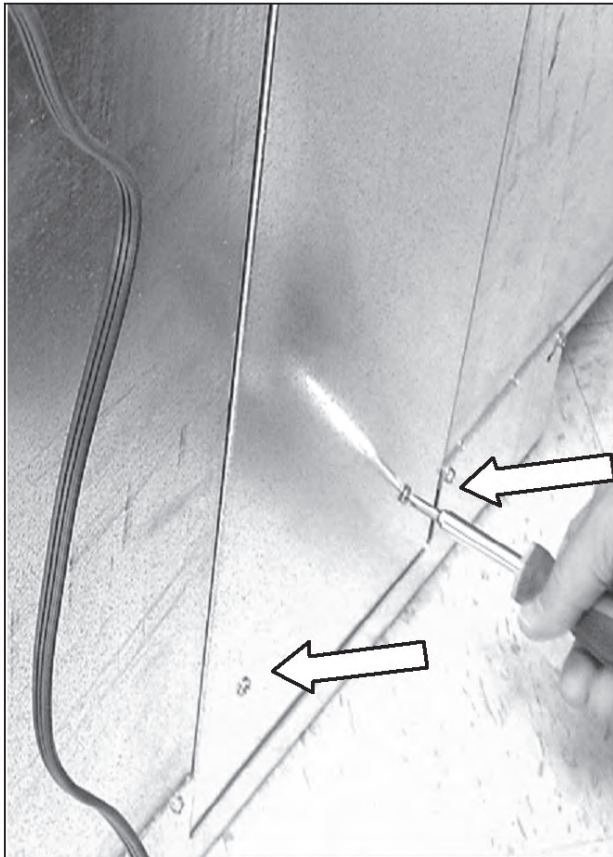

Figure 1

Loc Ring Connectors

When checking for refrigerant leaks always check the Loc Ring connectors, see figure 2

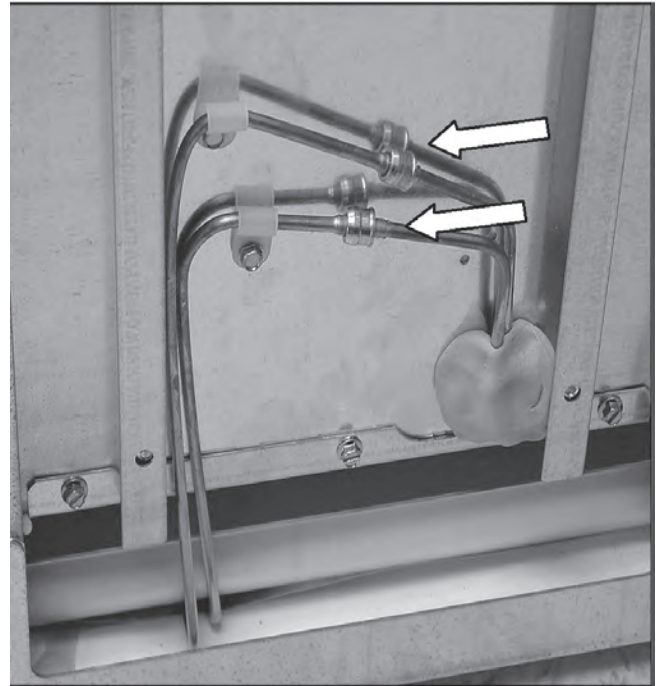

Figure 2

Water inlet Tube

2 screws secure the water fill tube to the cabinet, see figure 3



Figure 3

42" and 48" Jenn-Air SxS (continued)

Thermistor Location

⚠ WARNING



Electrical Shock Hazard

Disconnect power before servicing.

Replace all parts and panels before operating.

Failure to do so can result in death or electrical shock.

Thermistor Resistance

TEMP (°F)	RESISTANCE Ω (APPROX.)	TEMP (°F)	RESISTANCE Ω (APPROX.)
-5	25900-27500	45	5930-6300
0	22100-23500	50	5190-5510
5	18900-20000	55	4550-4830
10	16200-17200	60	4000-4240
15	13900-14800	65	3520-3730
20	12000-12800	70	3100-3300
25	10400-11000	75	2740-2910
30	8990-9550	80	2430-2580
32	8750	85	2160-2290
35	7800-8290	90	1920-2030
40	6800-7220		

The freezer thermistor is located on the right side of freezer cabinet wall. It is secured to the cabinet with 1/4" hex head screw.

The refrigerator thermistor is attached to the back wall of the refrigerator compartment.

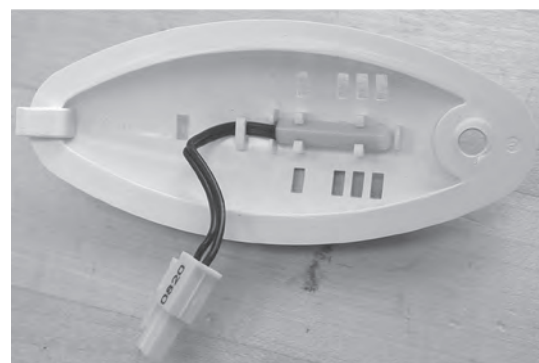
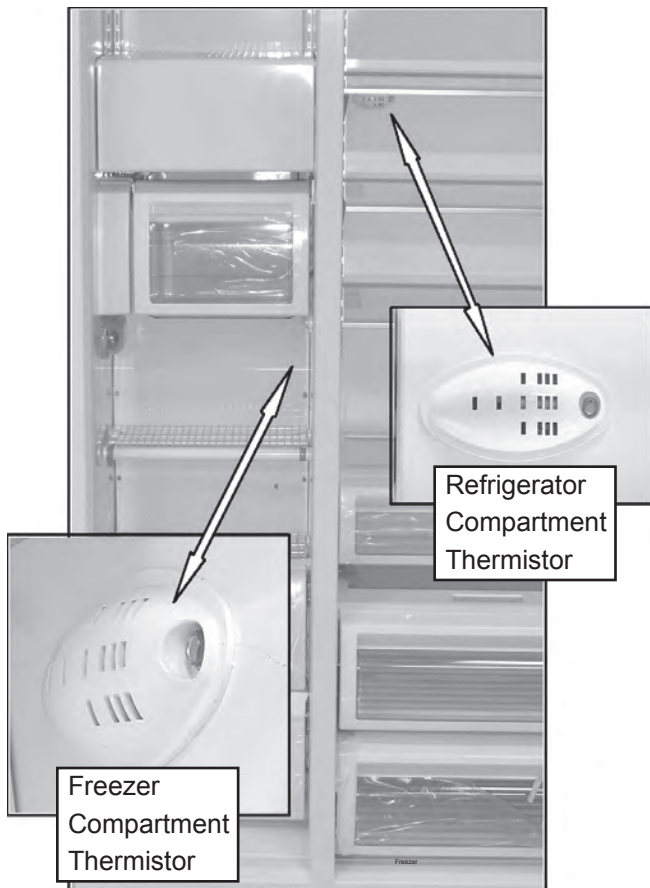

REMOVING A REFRIGERATOR LIGHT SOCKET BOTTOM MOUNT MODELS

⚠ WARNING



Electrical Shock Hazard
Disconnect power before servicing.
Replace all parts and panels before operating.
Failure to do so can result in death or electrical shock.

1. Unplug refrigerator or disconnect power.
2. If needed, remove the food and racks from the upper shelf.
3. Place the fingers of both hands into the light cover slots and pull the cover down.

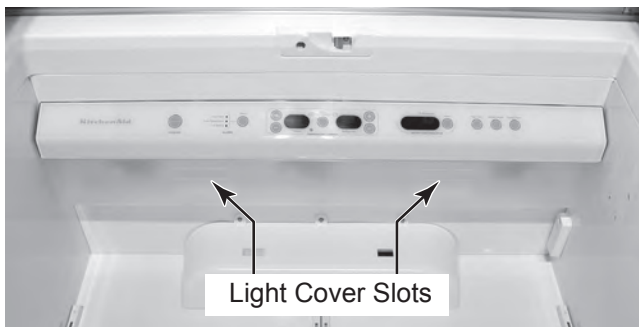

4. Unscrew the bulb from the light socket you are removing.

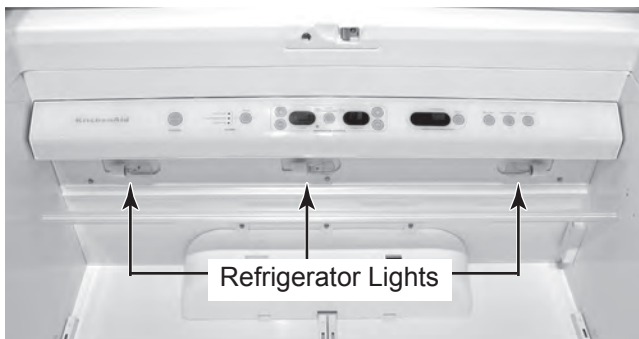

5. Using a small flat-blade screwdriver, push in on the light socket retainer, and pull the socket out of its opening in the refrigerator liner.

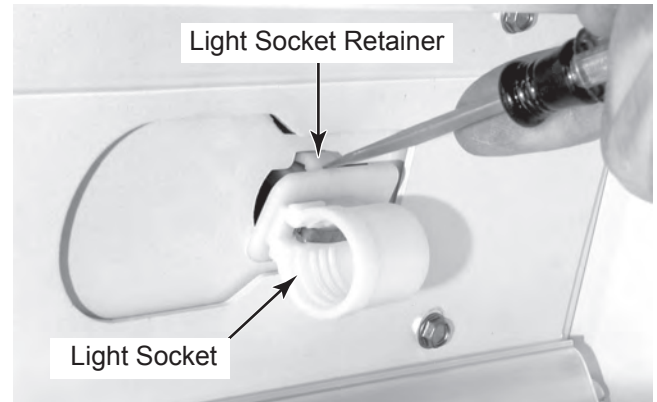

6. Disconnect the two wires from the bulb holder terminals and remove the holder.

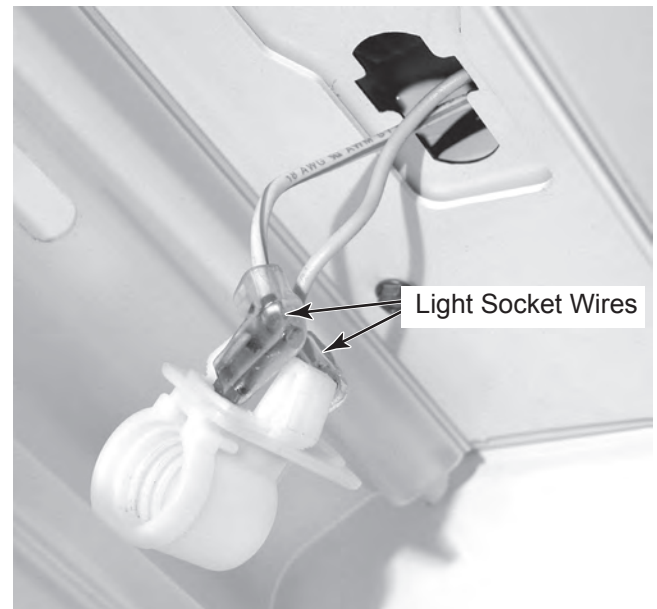

REMOVING THE USER INTERFACE ASSEMBLY BOTTOM MOUNT MODELS

⚠ WARNING



Electrical Shock Hazard

**Disconnect power before servicing.
Replace all parts and panels before
operating.**

**Failure to do so can result in death or
electrical shock.**

1. Unplug refrigerator or disconnect power.
2. If needed, remove the food and racks from the upper shelf.
3. Place the fingers of both hands into the light cover slots and pull the cover down.

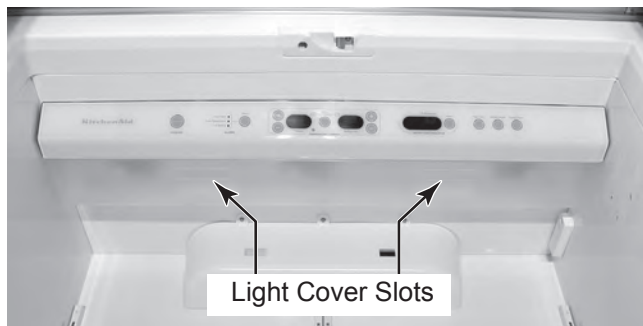

4. Remove the six hex-head screws from the user interface frame and remove the frame.

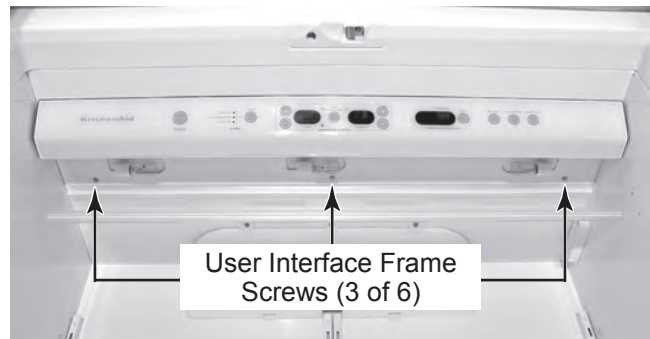

5. Pull the user interface assembly forward and remove it from the five retainer clips.

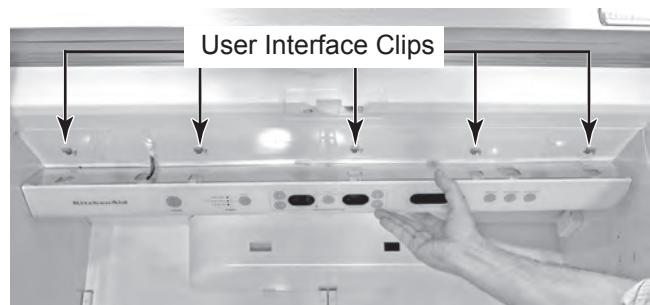

6. Unlock and disconnect the user interface connector from the wiring harness.



REMOVING THE REFRIGERATOR THERMISTOR BOTTOM MOUNT MODELS

⚠ WARNING



Electrical Shock Hazard
Disconnect power before servicing.
Replace all parts and panels before operating.
Failure to do so can result in death or electrical shock.

1. Unplug refrigerator or disconnect power.
2. If needed, remove the food and racks from the upper shelf.



3. Remove the hex-head screw from the refrigerator thermistor and pull the thermistor away from the liner.

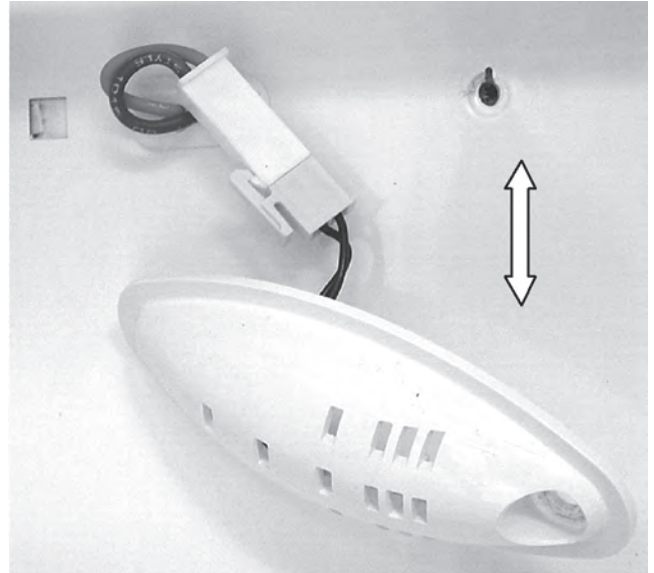

Remove 1/4" hex head screw

4. Unlock and disconnect the refrigerator thermistor connector from the wiring harness and remove the thermistor.



REMOVING THE REFRIGERATOR MOTORIZED AIR DOOR

! WARNING



Electrical Shock Hazard

**Disconnect power before servicing.
Replace all parts and panels before
operating.**

**Failure to do so can result in death or
electrical shock.**

1. Unplug refrigerator or disconnect power.
2. If needed, remove the food and racks from the upper shelf.



Motorized Air Door

3. Remove the three hex-head screws from the motorized air door cover.
4. Pull down on the motorized air door cover to unhook it from the rear clips and turn it over.

Motorized Air Door Cover Screws

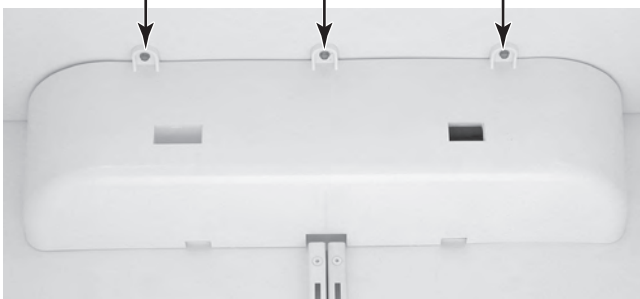

5. Unlock and disconnect the motorized air door connector from the wiring harness and remove the air door and cover.



Motorized Air Door Connector

6. Peel off the adhesive covering from over the motorized air door, and remove the air door from the cover.



Adhesive Covering

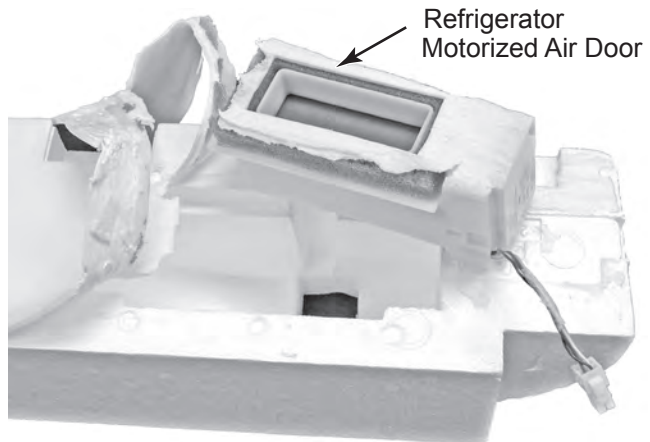

Refrigerator Motorized Air Door

REMOVING A REFRIGERATOR TEMP-CONTROLLED MOTORIZED AIR DOOR

! WARNING



Electrical Shock Hazard

Disconnect power before servicing.

Replace all parts and panels before operating.

Failure to do so can result in death or electrical shock.

1. Unplug refrigerator or disconnect power.
2. Remove the temp-controlled drawer for the motorized air door you are removing.

Temp-Controlled Motorized Air Doors

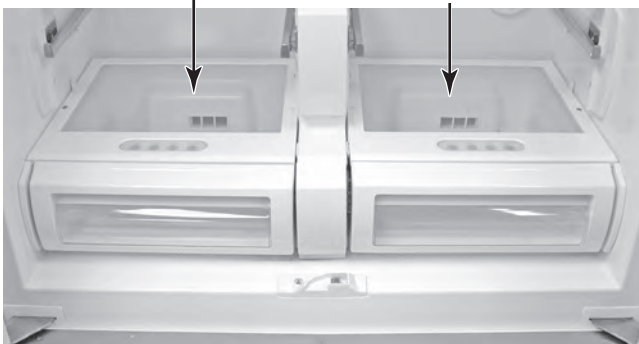

3. Remove the two hex-head screws from the motorized air door cover.
4. Pull the motorized air door assembly forward and turn it over.



5. Disconnect the motorized air door wire connector from the wire harness, and remove the air door.



6. Peel off the adhesive covering from over the motorized air door, and remove the air door.

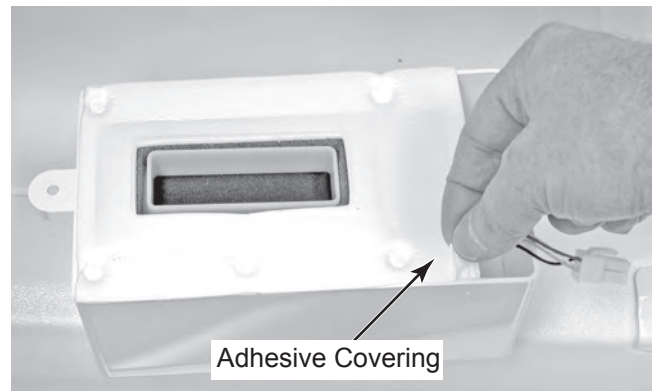

REMOVING A TEMP-CONTROLLED DRAWER COVER BOTTOM MOUNT MODELS

⚠ WARNING



Electrical Shock Hazard

Disconnect power before servicing.

Replace all parts and panels before operating.

Failure to do so can result in death or electrical shock.

1. Unplug refrigerator or disconnect power.
2. Remove the temp-controlled drawer for the cover you are removing.

NOTE: The temp-controlled drawer cover includes the user interface & LED lighting.

Temp-Controlled Drawer Covers



3. Remove the four (two on both sides) hex-head screws from the center divider cover (see the top right photo).

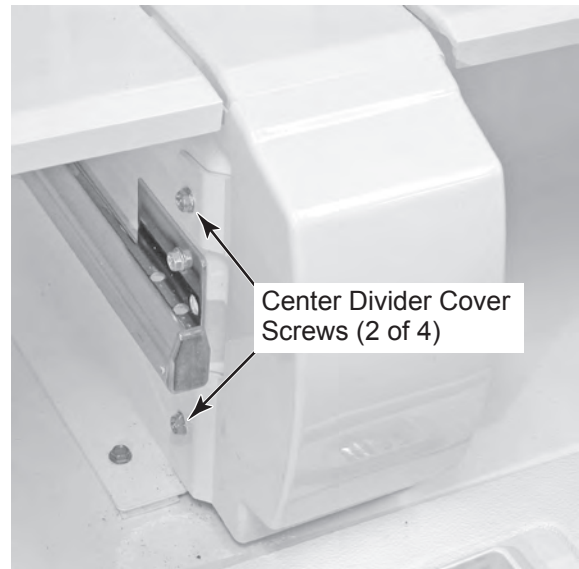

4. Rotate the front of the center divider cover up, pull out, and remove the cover.

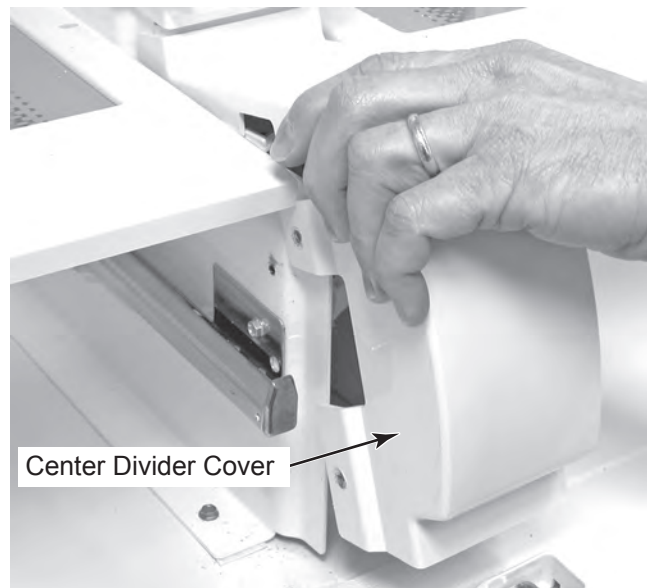

REMOVING A TEMP-CONTROLLED DRAWER COVER BOTTOM MOUNT MODELS (continued)

5. Disconnect the wire connector on the temp-controlled drawer cover from the wiring harness.

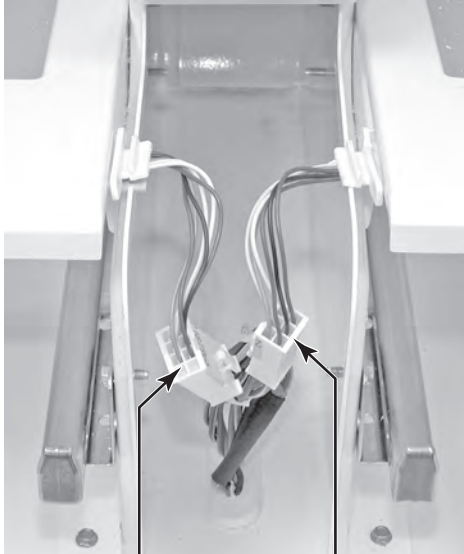

Left Cover Connector
(8-Pin)

Right Cover Connector
(6-Pin)

6. Remove the two screws from the temp-controlled drawer cover and remove the cover.



REMOVING THE HEATED FLIPPER MULLION AND AN ACTUATOR / ELECTRICAL CONTACT 42" FRENCH DOOR

⚠ WARNING



Electrical Shock Hazard

Disconnect power before servicing.

Replace all parts and panels before operating.

Failure to do so can result in death or electrical shock.

1. Unplug refrigerator or disconnect power.
2. Open the left refrigerator door.
3. **To remove the heated flipper mullion:**
 - a) Rotate the flipper mullion out.



- b) While lifting the flipper mullion, insert a small flat-blade screwdriver behind each of the three mullion retainer clips, pry the pins out of the door liner holes, and remove the flipper mullion.

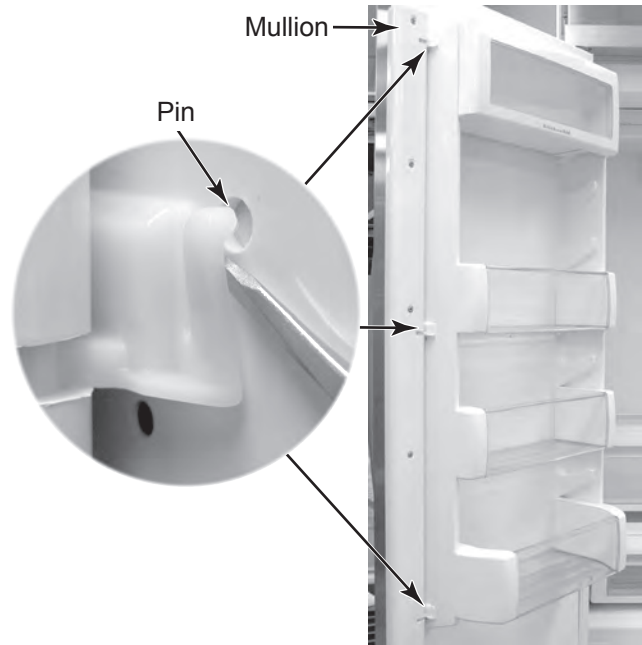

REMOVING THE HEATED FLIPPER MULLION AND AN ACTUATOR / ELECTRICAL CONTACT 42" FRENCH DOOR (continued)

4. To remove the top or bottom heated flipper mullion actuator/electrical contact:

a) Open the refrigerator doors.

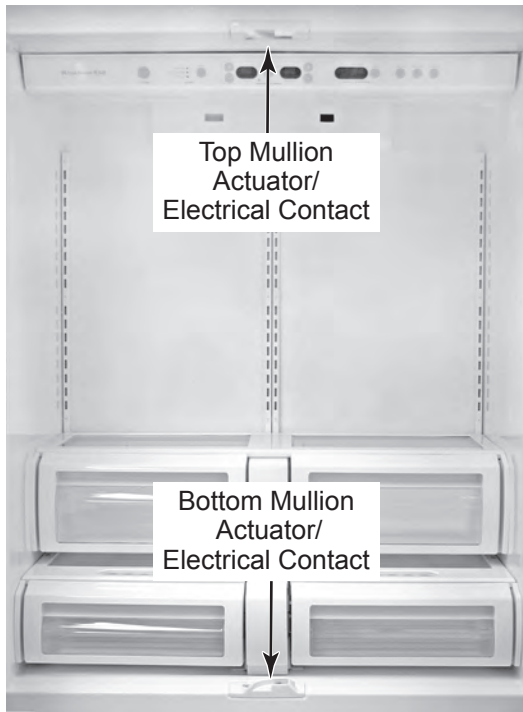

- d) Remove the two hex-head screws from the actuator/electrical contact.

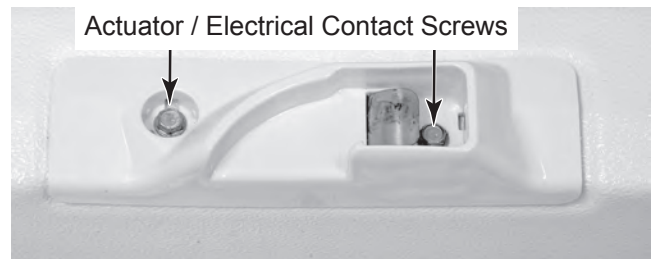

- e) Disconnect the spade connector from the actuator/electrical contact terminal.

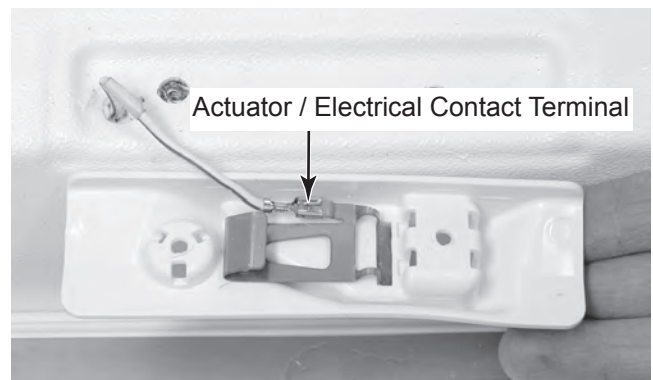

- b) Use a flat-blade screwdriver, and unscrew the cap from the actuator/electrical housing.

- c) Pry off the cover from the actuator/electrical contact.

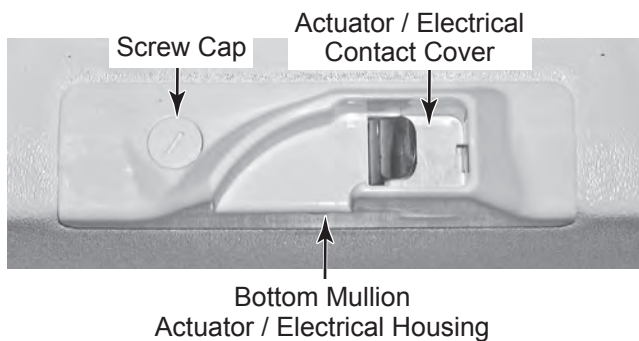

ACCESSING THE MACHINE COMPARTMENT

⚠ WARNING



Electrical Shock Hazard

Disconnect power before servicing.

Replace all parts and panels before operating.

Failure to do so can result in death or electrical shock.

The ON/OFF switch controls the power supply to all refrigerator components.

Three access panels enclose the machine compartment components. 1/4" Hex head screws secure panel #1 to panel #2 and panel #2 to the cabinet and to panel #3. In most cases panels #1 and #2 need to be removed when servicing.

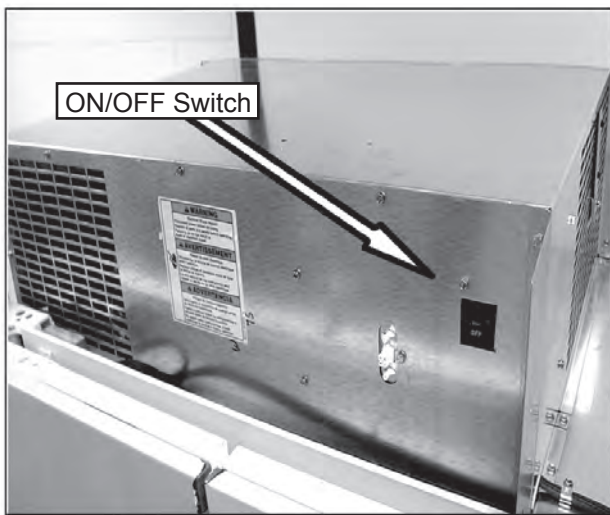
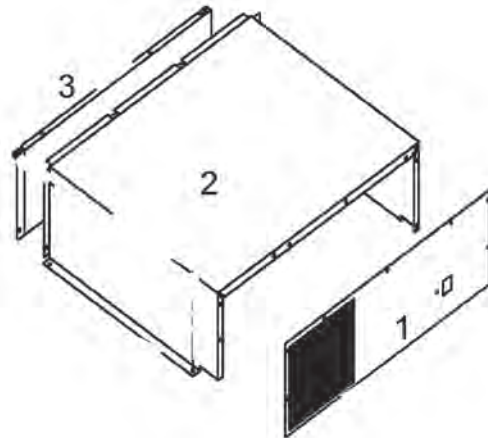

Component Identification

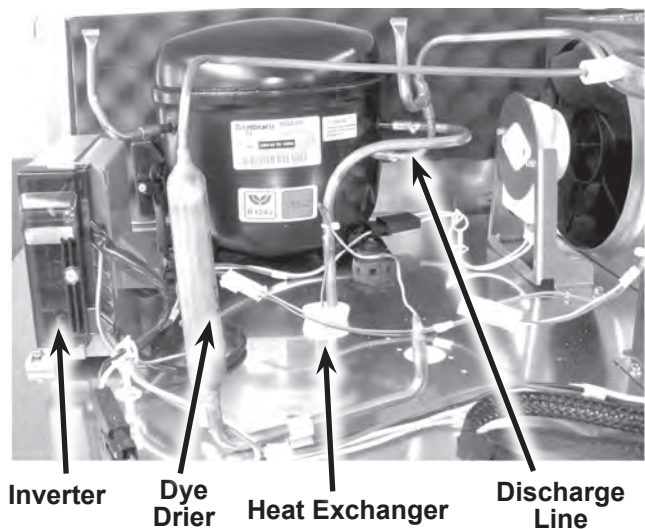

ACCESSING THE MACHINE COMPARTMENT (continued)

Electronic Control Board Identification

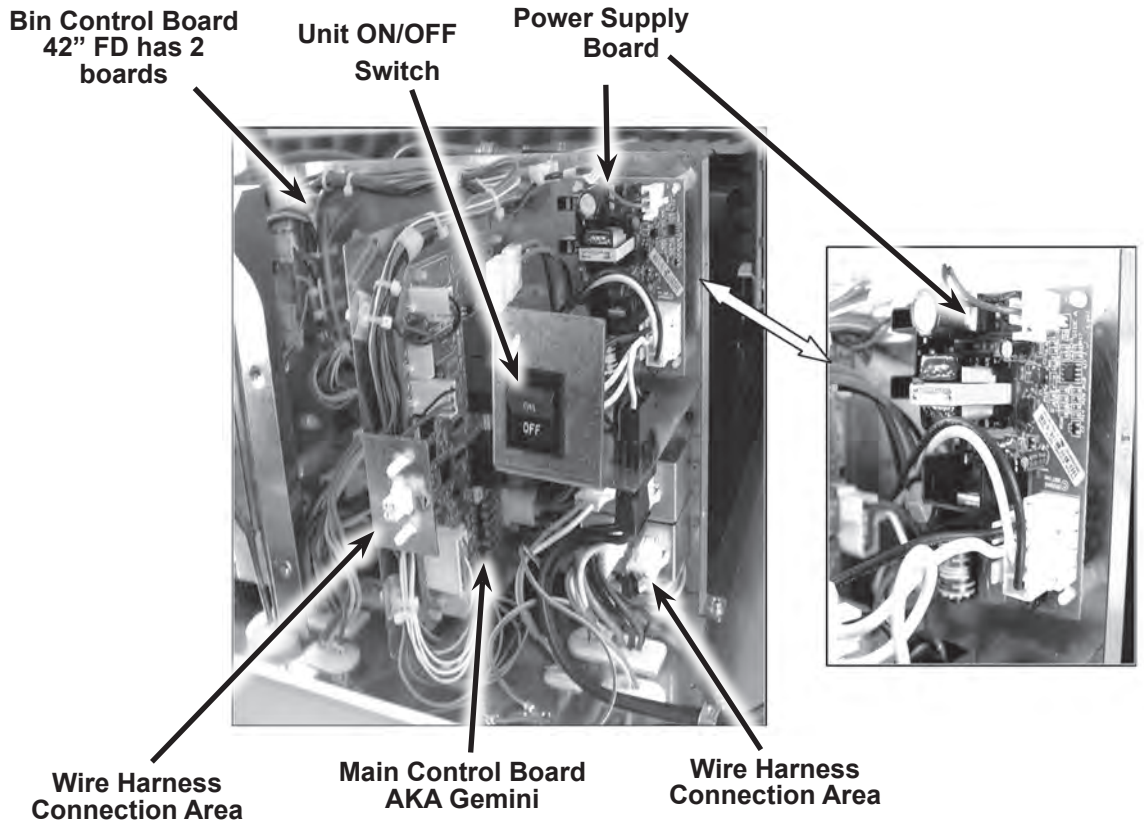

Connector and Pin Number Identification

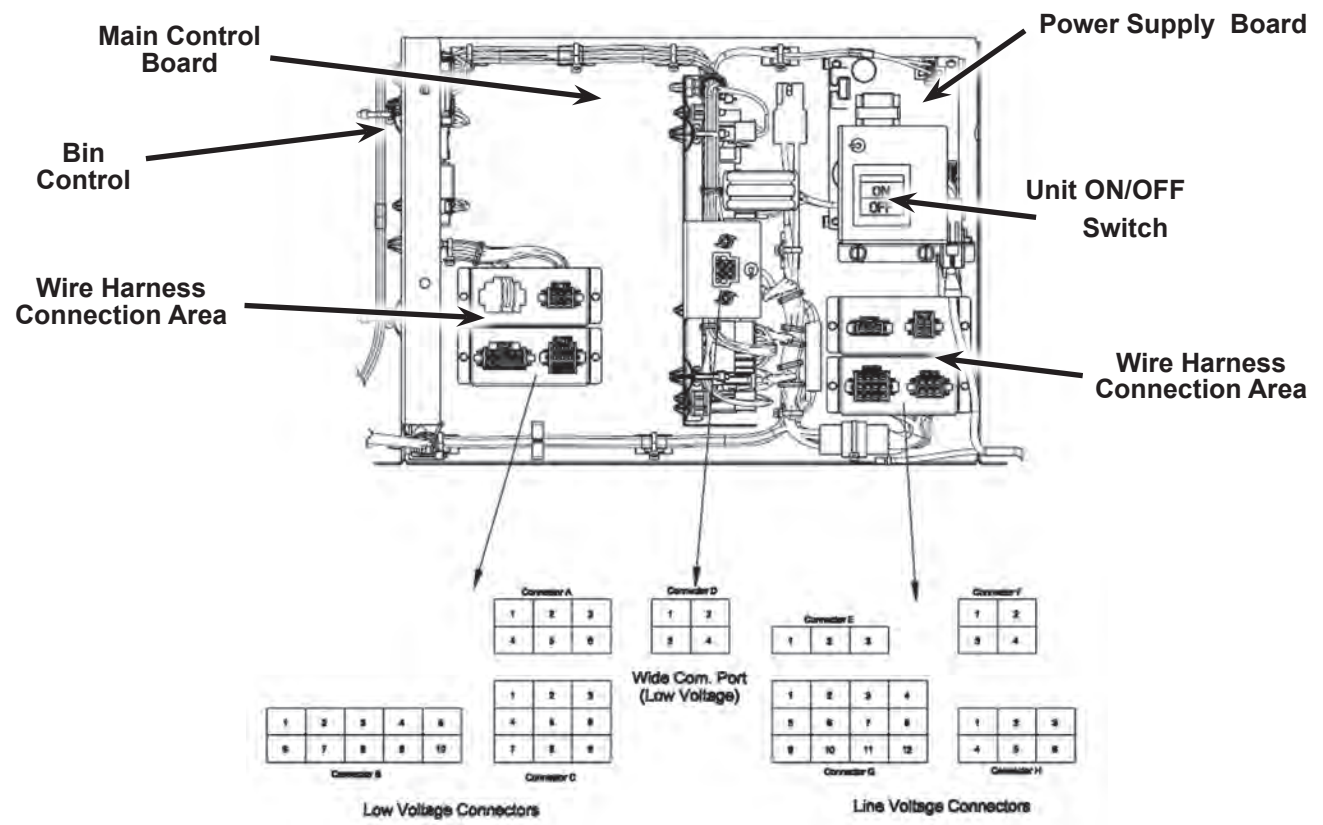

ACCESSING THE MACHINE COMPARTMENT (continued)

Lock Ring Connections

There are 2 Lock Ring connectors located behind the electronic control board cluster. These connectors cannot be seen or accessed without removing the top machine compartment panel. Always check these 2 connectors when looking for a refrigerant leak.

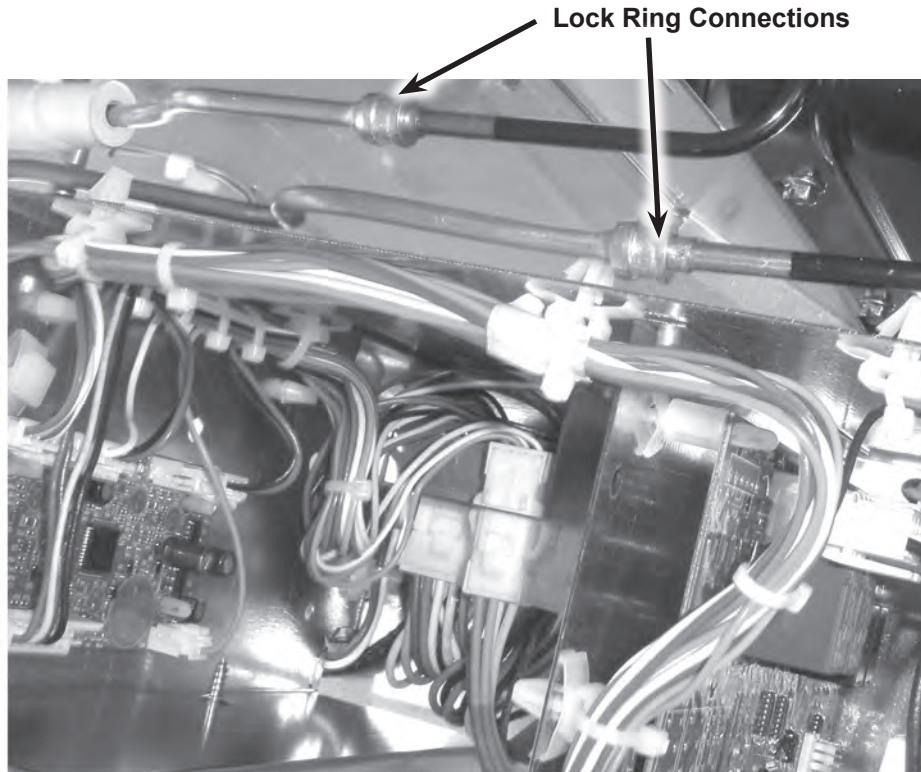

Condenser

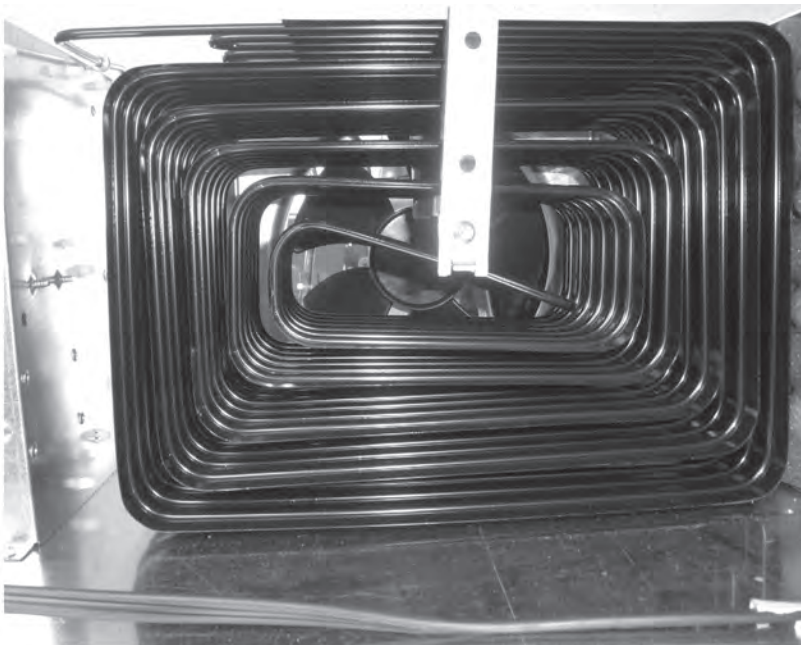

This refrigerator uses a jelly roll condenser. This design condenser does not need to be cleaned under normal circumstances. A separator is used to keep the condenser tubing from vibrating. The isolator can be dislodged when the refrigerator is transported.

Jelly Roll Condenser

REMOVING THE FREEZER DRAWER SWITCH BOTTOM MOUNT PRODUCT

⚠ WARNING



Electrical Shock Hazard

Disconnect power before servicing.

Replace all parts and panels before operating.

Failure to do so can result in death or electrical shock.

1. Unplug refrigerator or disconnect power.
2. Remove the freezer drawer (see page 4-20 for the procedure).

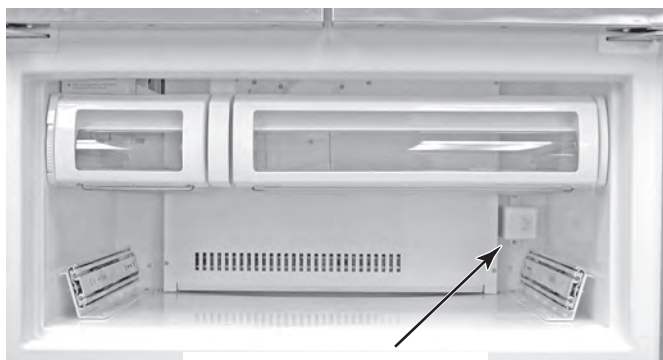

3. Remove the two hex-head screws from the freezer drawer switch housing and remove the housing.

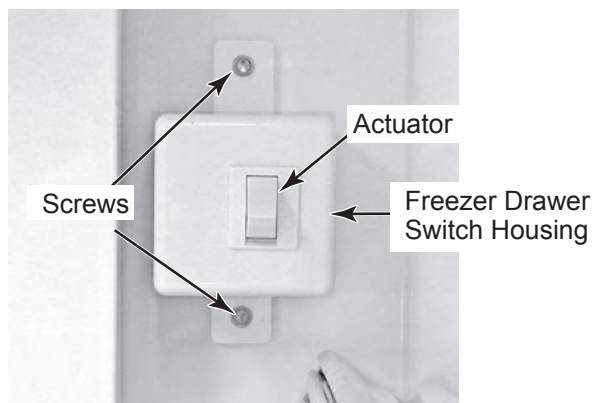

4. Disconnect the two wires from the freezer drawer switch terminals.

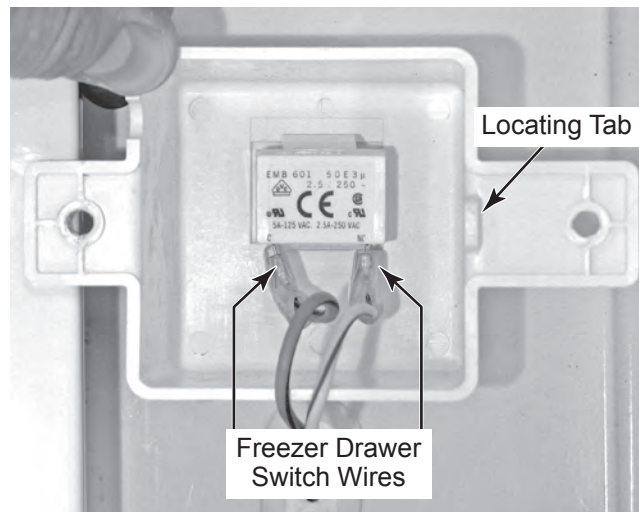

5. Push the freezer drawer switch out of the housing cutout.

REASSEMBLY NOTE: When you install the switch in the housing, make sure that you position it with the locating tab and actuator as shown.

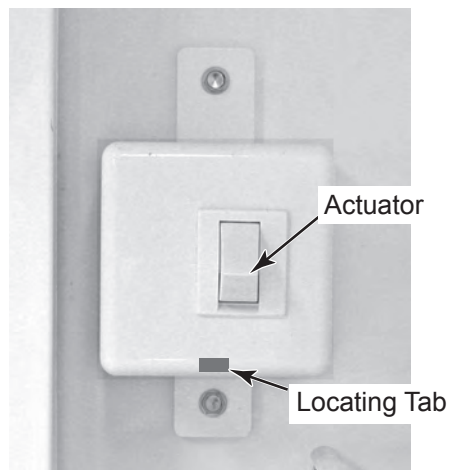

— NOTES —

COMPONENT TESTING

BOTTOM MOUNT REFRIGERATORS

FOR SERVICE TECHNICIAN'S USE ONLY

Tech Sheet

Do not discard

⚠ DANGER



Electrical Shock Hazard

Only authorized technicians should perform diagnostic voltage measurements.

After performing voltage measurements, disconnect power before servicing.

Failure to follow these instructions can result in death or electrical shock.

⚠ WARNING



Electrical Shock Hazard

Disconnect power before servicing.

Replace all parts and panels before operating.

Failure to do so can result in death or electrical shock.

Voltage Measurement Safety Information

When performing live voltage measurements, you must do the following:

- Verify the controls are in the off position so that the appliance does not start when energized.
- Allow enough space to perform the voltage measurements without obstructions.
- Keep other people a safe distance away from the appliance to prevent potential injury.
- Always use the proper testing equipment.
- After voltage measurements, always disconnect power before servicing.

Before testing any of the components, perform the following checks:

- Control failure can be the result of corrosion on connectors. Therefore, disconnecting and reconnecting wires will be necessary throughout test procedures.
- All tests/checks should be made with a VOM or DVM having a sensitivity of 20,000 ohms-per-volt DC, or greater.
- Check all connections before replacing components, looking for broken or loose wires, failed terminals, or wires not pressed into connectors far enough.
- Resistance checks must be made with power cord unplugged from outlet, and with wiring harness or connectors disconnected.
- Unless stated otherwise, make all resistance checks by disconnecting the component connector at the Central Control Unit (CCU).

COMPONENT SPECIFICATIONS

⚠ WARNING



Electrical Shock Hazard

Disconnect power before servicing.
 Replace all parts and panels before operating.
 Failure to do so can result in death or electrical shock.

THERMISTOR



Refer to page 4-15 for the procedure for accessing the thermistor.

1. Unplug refrigerator or disconnect power.
2. Disconnect the thermistor connector from the wiring harness.
3. Set the ohmmeter to the R x 10 scale.
4. Touch the ohmmeter test leads to the connector pins. The meter should indicate as shown in the chart.

NOTE: If the resistance of the thermistor is normal, perform the following voltage test.

5. Set the voltmeter to read a maximum voltage of 10 volts DC.
6. Attach meter leads to Thermistor harness.

7. Connect power to the refrigerator and allow it to enter the “cooling” mode. With the refrigerator in the cooling mode, The meter should indicate approximately 5 volts DC.
8. Unplug refrigerator or disconnect power.
9. Connect Thermistor and install
10. Plug in refrigerator or connect power

TEMP (°F)	RESISTANCE Ω (APPROX.)	TEMP (°F)	RESISTANCE Ω (APPROX.)
-5	25900-27500	45	5930-6300
0	22100-23500	50	5190-5510
5	18900-20000	55	4550-4830
10	16200-17200	60	4000-4240
15	13900-14800	65	3520-3730
20	12000-12800	70	3100-3300
25	10400-11000	75	2740-2910
30	8990-9550	80	2430-2580
32	8750	85	2160-2290
35	7800-8290	90	1920-2030
40	6800-7220		

COMPONENT SPECIFICATIONS (continued)



! WARNING

Electrical Shock Hazard

Disconnect power before servicing.
Replace all parts and panels before operating.
Failure to do so can result in death or electrical shock.

HEATED FLIPPER MULLION 42" FRENCH DOOR

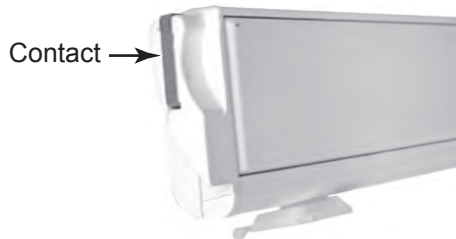

Refer to page 4-10 for the procedure for accessing the heated flipper mullion.

1. Unplug refrigerator or disconnect power.
2. Open the left refrigerator door.
3. Set the ohmmeter to the R x 1 scale.
4. Touch the ohmmeter test leads to the metal contacts at the top and bottom of the mullion. The meter should indicate between 110 & 125 Ω .

MOTORIZED AIR DOOR



Refer to pages 4-6 & 4-7 for the procedures for accessing the refrigerator and temp-controlled motorized air doors.

1. Run the diagnostics tests (see page 6-2) and check for the proper operation of the air door.

NOTE: A 12 volt DC square wave is supplied to the air door in a series of short pulses. It is not possible to obtain a reliable voltage reading with a VOM. The remaining steps will allow you to check the resistance of the air door motor.

2. Unplug refrigerator or disconnect power.
3. Disconnect the motorized air door wire connector from the main harness.
4. Set the ohmmeter to the R x 10 scale.
5. Touch one of the ohmmeter test leads to the motorized air door connector with the yellow wire and the other test lead to the red wire. The meter should indicate approximately 375 to 425 Ω .
6. Touch one of the ohmmeter test leads to the motorized air door connector with the white wire and the other test lead to the blue wire. The meter should indicate approximately 375 to 425 Ω .

COMPONENT SPECIFICATIONS (continued)



⚠ WARNING

Electrical Shock Hazard

Disconnect power before servicing.

Replace all parts and panels before operating.

Failure to do so can result in death or electrical shock.

CONDENSER FAN MOTOR



1. Run the diagnostics tests (see page 6-2) and check for the proper operation of the condenser fan motor in step 04.

NOTE: During the condenser fan motor operation, 120 volts AC will be present at pins 1 and 4.

EVAPORATOR FAN MOTOR



1. Run the diagnostics tests (see page 6-2) and check for the proper operation of the evaporator fan motor in step 03.

NOTE: During the evaporator fan motor operation, 5 to 17 volts DC will be present at the yellow and white wires. A constant 12 volts at the red and white wires will be present anytime the fan motor is operating. The remaining steps will allow you to check the resistance of the evaporator fan motor.

2. Unplug refrigerator or disconnect power.
3. Disconnect the wire connector going to the evaporator fan motor.
4. Set the ohmmeter to the R x 10K scale.
5. Touch the ohmmeter test leads to pins 1 (white wire) and 4 (red wire) of the evaporator fan motor connector. The meter should indicate approximately 1400 to 1700 Ω .

COMPONENT SPECIFICATIONS (continued)



! WARNING

Electrical Shock Hazard

Disconnect power before servicing.
Replace all parts and panels before operating.
Failure to do so can result in death or electrical shock.

DOOR/DRAWER SWITCH



1. Unplug refrigerator or disconnect power.
2. Disconnect one of the wires going to the door/drawer switch.
3. Set the ohmmeter to the R x 1 scale.
4. Touch the ohmmeter test leads to the N.O. and COM door/drawer switch terminals. The meter should indicate an open circuit (infinite).
5. Press the door/drawer switch actuator button and the meter should indicate continuity (0 Ω).
6. Touch the ohmmeter test leads to the N.C. and COM door/drawer switch terminals. The meter should indicate continuity (0 Ω).

NOTE: The door/drawer switches are normally closed.

7. Press the door/drawer switch actuator button and the meter should indicate an open circuit (infinite).

FILL TUBE HEATER



NOTE: The heated fill tube will be energized for 90 minutes after each ice maker harvest and fill.

1. Unplug refrigerator or disconnect power.
2. Disconnect the ice maker inlet heated fill tube wire connector from the main harness.
3. Set the ohmmeter to the R x 1K scale.
4. Insert the ohmmeter test leads into the two connector pins of the ice maker inlet heated fill tube connector. The meter should indicate approximately 3420 Ω .

COMPONENT SPECIFICATIONS (continued)



⚠ WARNING

Electrical Shock Hazard

Disconnect power before servicing.

Replace all parts and panels before operating.

Failure to do so can result in death or electrical shock.

DEFROST HEATER & BIMETAL



WATER VALVE

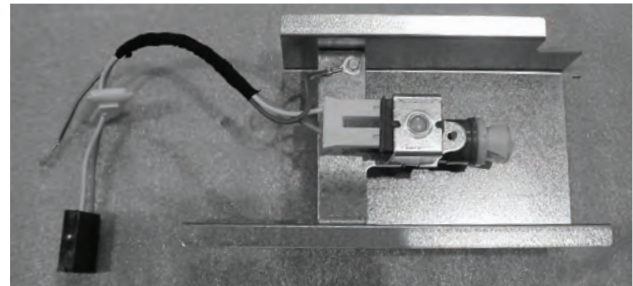

1. Run the diagnostics tests (see page 6-2) and check for the proper operation of the defrost heater and bimetal in step 07.

NOTE: If the bimetal is closed, the voltage at the defrost heater terminals will be 120 volts AC. The remaining steps will allow you to check the resistance of the defrost heater and bimetal.

2. Unplug refrigerator or disconnect power.
3. Disconnect one of the wires going to the defrost heater.
4. Set the ohmmeter to the R x 1 scale.
5. Touch the ohmmeter test leads to the defrost heater terminals. The meter should indicate approximately 15 to 25 Ω .
6. Touch the ohmmeter test leads to the defrost bimetal wire connectors. The meter should indicate as follows:
 - With the bimetal below 20°F, the meter should indicate continuity (0 Ω).
 - With the bimetal above 46°F (8.9°C), the meter should indicate an open circuit (infinite). The bimetal will close @ 34°F (1.1°C).

1. Unplug refrigerator or disconnect power.
2. Disconnect the wire connectors from the water valve solenoid terminals.
3. Set the ohmmeter to the R x 1 scale.
4. Touch the ohmmeter test leads to the solenoid terminals. The meter should indicate approximately 180 to 190 Ω .

ADJUSTING THE FREEZER DOOR BOTTOM MOUNT MODELS



⚠ WARNING

Electrical Shock Hazard

Disconnect power before servicing.

Replace all parts and panels before operating.

Failure to do so can result in death or electrical shock.

1. Unplug refrigerator or disconnect power.

NOTE: This adjustment allows you to level the freezer door with the cabinet surface to avoid leakage and frost from occurring.

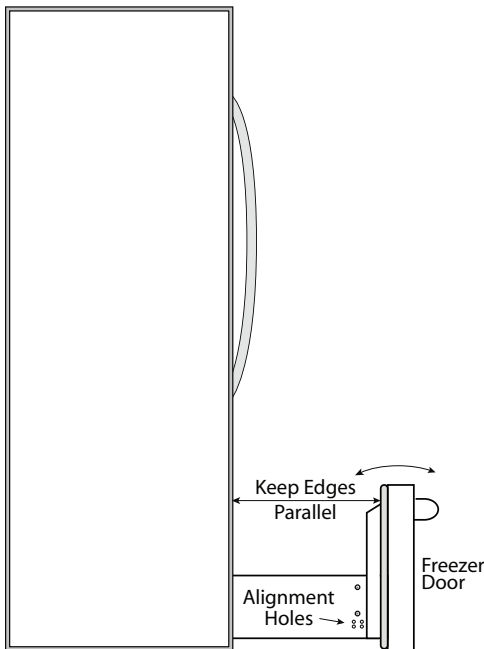

2. Pull the freezer drawer out.
3. Remove the food from the drawer.
4. Lift the liner out of the freezer drawer.
5. Remove the bottom T-15 screw from both sides of the the freezer drawer front.
6. Close the freezer drawer and adjust the door front so that it is properly aligned and the gasket seats evenly against the cabinet.

NOTE: The cabinet trims may need to be removed to view the door seal.

7. Without moving the freezer drawer front, slowly open the freezer drawer, and locate one of the holes in the left and right four hole groupings that are properly aligned.
8. Install the two screws you removed in step 5, in the left and right aligned holes, and tighten them securely.
9. Close the freezer drawer, and make sure that the gasket seats securely against the

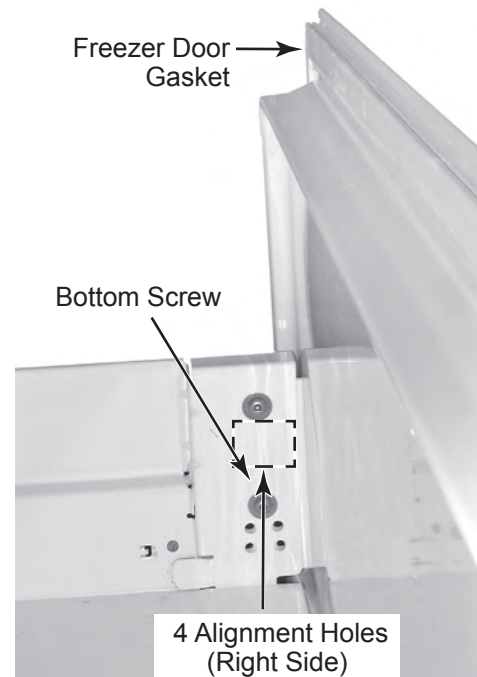

DIAGNOSTICS & TROUBLESHOOTING

BOTTOM MOUNT MODELS



⚠ WARNING

Electrical Shock Hazard

Disconnect power before servicing.

Replace all parts and panels before operating.

Failure to do so can result in death or electrical shock.

ELECTRONIC CONTROL FEATURES

The electronic control in the refrigerator controls the temperatures in the refrigerator and freezer compartments independently. It delays the operation of the evaporator fan (optional), pulses the defrost heater, and monitors the water filter usage. The fan delay and pulsed defrost features are controlled in the following manner:

- Pulsed Defrost Heat - During the defrost cycle, the heater is energized continuously for the first 2 minutes. It is then cycled off for 60 seconds, and on for 120 seconds. The on/off cycle is repeated until the bimetal opens, or the maximum defrost time (25 minutes) is reached.

SERVICE DIAGNOSTICS MODE

As a requirement to run the Service Diagnostics routine, the appliance must be turned ON. The Service Diagnostics Mode is entered by pressing the following 2 key sequence:

Press and hold the RC Temp Increase key, and then the Power key, and hold both down for 3 seconds.

Use the Component Evaluation Mode chart below to diagnose the components. When the technician is satisfied that the first component has passed the test, continue with the next component evaluation by pressing either the RC

Temp UP key, or the Up arrow key. The routine will end automatically after all the steps are completed, or after 20 minutes have elapsed, whichever occurs first. The control will then resume the normal cooling mode.

SERVICE TIP: If the control does not respond, it may be necessary to remove power from the refrigerator for a few seconds. Reconnect power, and perform the service diagnostics routine to verify that the control is working properly.

If the bimetal is by-passed for testing (if applicable), do not overheat the evaporator area.

Component Description	FC Sequence No.	RC Code	RC Code Description
FC Thermistor	01	01	Freezer Thermistor within Operating Region
		02	Freezer Thermistor within "Open Region"
		03	Freezer Thermistor within "Short Region"
RC Thermistor	02	01	Refrigerator Thermistor within Operating Region
		02	Refrigerator Thermistor within "Open Region"
		03	Refrigerator Thermistor within "Short Region"
Evaporator Fan Motor	03	- -	Evaporator Fan Motor ON
Condenser Fan Motor	04	- -	Condenser Fan Motor ON
VC Compressor	05	01	VC Compressor ON at 4500 RPM
		02	VC Compressor OFF, waiting for min off delay
Air Door	06	- -	Air Door opens to full position then closes and stops
Defrost Heater/Bi-metal	07	01	Defrost Heater energized / Bi-Metal Closed
		02	Defrost Heater energized / Bi-Metal Open
Bin Accent Lighting	08	- -	Turn on Bin Accent Lighting for this step only
Left Bin Thermistor	09	01	Left Bin Thermistor within Operating Region
		02	Left Bin Thermistor within "Open Region"
		03	Left Bin Thermistor within "Short Region"
Left Bin User Selection /LED test	10	01	Correct key press
		02	Incorrect key press
Left Bin Air Door	11	- -	Air Door opens to full position then closes and stops
Right Bin Thermistor	12	01	Right Bin Thermistor within Operating Region
		02	Right Bin Thermistor within "Open Region"
		03	Right Bin Thermistor within "Short Region"
Right Bin User Selection /LED test	13	01	Correct key press
		02	Incorrect key press
Right Bin Air Door	14	- -	Air Door opens to full position then closes and stops
End Routine			Resume normal cooling

SERVICE INFORMATION

- The compressor suction and process stubs can not be interchanged.
- Refrigerant charge must be applied to the high side only.
- **NOTE:** The ice maker cycle must be initiated electrically. Do not try to manually start the cycle.
- Service defrost bimetals open at 50°F.
- The defrost timer may contain a capacitor in series with the motor. Do not test for continuity when checking for a failed timer motor. Instead, energize the timer, and listen for gear movement.
- The part number can be found on the component.
- **IMPORTANT:** Refrigerant must be handled by a licensed, EPA-certified refrigerant technician in accordance with established procedures. Remove the refrigerant from the existing system per the instructions provided with the recovery system being used.

NOTE: Watt and pressure readings will vary, and are influenced by the existing condition of the appliance, such as an iced-up evaporator, the condition of the condenser, the defrost cycle, pull-down time, and customer use.

- Normal operating conditions are viewed when the air and temperature controls are at mid-setting, the freezer section is at 0 to 5°F, and the refrigerator is cycling.

PERFORMANCE DATA • (NORMAL OPERATING CONDITIONS)			
AMB	WATTS	SYSTEM PRESSURE (PSIG)	
		HIGH SIDE	LOW SIDE
70°	140±20	95±20	-7 TO 3
90°	150±20	135±20	-4 TO 3
110°	170±20	185±20	-2 TO 4

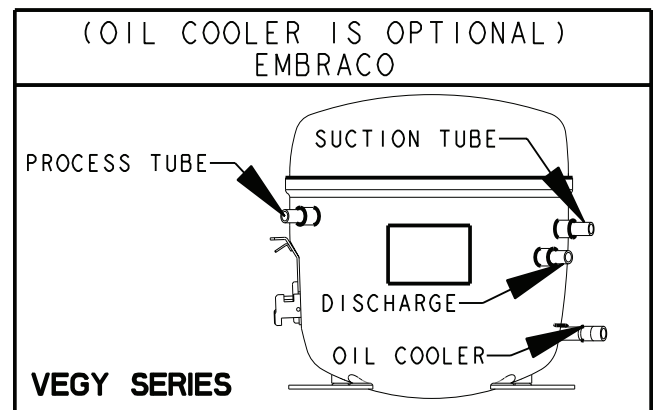

SERVICEABLE ELECTRICAL PARTS MATRIX COMPONENTS

SERVICEABLE PARTS	Part No.	Watt/Res.
COMPRESSOR	2223393	70-130W @120 Vac
RUN WINDINGS	*	6.4Ω
START WINDINGS	*	6.4Ω
INVERTER ASSY	2306957	Supply Voltage 120 Vac
THERMISTOR (RC & FC)	2213442	NTC 2.7kΩ@25°C 23kΩ@0F, 7.6kΩ@37F
AIR Baffle ASSY	2220377	12 VDC @ 300 pps, Blue to White & Red to Yellow both 415±45Ω
MAIN CONTROL BOARD (GEMINI)	2304135	Supply Voltage 120 Vac
ICC (DELI) CONTROL BOARD (PHOENIX)	2303091	Supply Voltage 120 Vac
DEFROST HEATER	2306176	740 W (19.4Ω)@120 Vac
MAIN U.I. (TOP OF RC)	2309244	

SERVICEABLE PARTS	Part No.	Watt/Res.
CONDENSER FAN	2206036	3±1W@120 Vac
EVAPORATOR FAN	2259385	2-5W@12 Vdc
DEFROST BI-METAL	2309373	
FILL TUBE HEATER	2221240	4.2W±5% (3.4kΩ)@120 Vac
FLIPPER MULLION ASSY	2307938	5W±7.5% (115Ω)@24 Vdc
ICC - DELI COVER SHELF ASSY, RH	2309009	
ICC - DELI COVER SHELF ASSY, LH	2309008	
ICEMAKER OPTICS EMITTER	2220398	
ICEMAKER OPTICS RECEIVER	2255114	

— NOTES —

SERVICE AND WIRING 42 and 48" SXS

! WARNING



Electrical Shock Hazard
Disconnect power before servicing.
Replace all parts and panels before operating.
Failure to do so can result in death or electrical shock.

Normal operating conditions are viewed when the air and temperature controls are at mid-setting, freezer section 0 to 5°F and unit is cycling.

NOTE: Watt and pressure readings will vary and are influenced by the existing condition of the appliance, such as iced-up evaporator, condition of condenser, defrost cycle, pull-down time and customer use.

PERFORMANCE DATA (NORMAL OPERATION CONDITIONS)				
AMB	WATTS	SYSTEM PRESSURE (PSIG)		
		HIGH SIDE	LOW SIDE	
70°	140±20	95±20	-7 TO 3	
90°	150±20	135±20	-4 TO 3	
110°	170±20	185±20	-2 TO 4	

(OIL COOLER IS OPTIONAL)
 EMBRACO

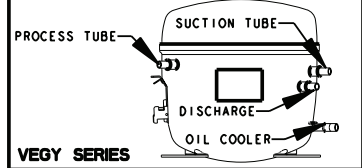

SERVICE INFORMATION (W10234139 B)

- COMPRESSOR SUCTION AND PROCESS STUBS CAN NOT BE INTERCHANGED.
- REFRIGERANT CHARGE MUST BE APPLIED TO HIGH SIDE ONLY.
- NOTE: ICE MAKER CYCLE MUST BE INITIATED ELECTRICALLY. DO NOT TRY TO MANUALLY START CYCLE.
- SERVICE DEFROST BIMETALS - 50° F OPEN.
- PART NUMBER CAN BE FOUND ON THE COMPONENT.

SERVICEABLE ELECTRICAL PARTS MATRIX COMPONENTS

SERVICEABLE PARTS	Part No.	Watt/Res.	SERVICEABLE PARTS	Part No.	Watt/Res.
COMPRESSOR	2223801	70-130W @120 VAC	CONDENSER FAN MOTOR	2188875	3±1W@120 VAC
RUN WINDINGS	*	6.4Ω	EVAPORATOR FAN MOTOR	2259385	2-5W@12 VDC
START WINDINGS	*	6.4Ω	DEFROST BI-METAL	2321803	
INVERTER ASSY	W10133449	Supply Voltage 120 VAC	ICEMAKER OPTICS EMITTER	W10193840	
THERMISTOR (RC & FC)	2188820	NTC 2.7kΩ@25°C 23kΩ@0F, 7.6kΩ@37F	ICEMAKER OPTICS RECEIVER	W10193666	
AIR BAFFLE ASSY RC & ICC	2220377	12 VDC @ 300 pps, Blue to White & Red to Yellow both 415±45Ω	COVER ASSY- CRISPER, 36 BM	W10203635	14 VDC INPUT
MAIN CONTROL BOARD (GEMINI FLASH)	W10200659	Supply Voltage 14 VDC	FILL TUBE HEATER	2221240	4.2W±5% (3.4kΩ)@120 VAC
MAIN CONTROL BOARD POWER SUPPLY	W10120824	120 VAC PRIMARY 14 VDC SECONDARY	CONTROL-ELEK(PAN)	W10184634	14 VDC INPUT
DEFROST HEATER	2268393	581 W (24.7Ω)@120 VAC			
CONTROL BOX ASSY (TOP OF RC)	W10196640				

ELECTRONIC CONTROL FEATURES

The electronic control in this appliance maintains the temperature, controlling the operation and speed of the compressor as well as the evaporator fan motor. The Adaptive Defrost Control (ADC) portion of the electronic control utilizes "Pulsed Defrost" technology to perform defrost function. (See troubleshooting tips for more information)

- Pulsed Defrost Heat - During the defrost cycle the heater is energized continuously for the first 7 minutes. It is then cycled off for 60 seconds and on for 120 seconds. The on/off cycle is repeated until the bi-metal opens or the maximum defrost time (33 minutes) is reached.

SERVICE DIAGNOSTICS MODE

Product must be on to enter service diagnostic mode. Press the RC Temp increase key and the Cooling On/Off key simultaneously for 3 seconds. The 2-digit FC display shows the diagnostic step. Steps 00 through 07 are for input/output circuits of the main control board. Steps 10 through 13 are for the pan control board.

The FC+ and FC- buttons switch between control boards. The Set to Recommended and °F/°C buttons switch between steps. The 2-digit RC display shows the status for input circuits or the option for output circuits. The RC+ and RC- buttons switch between options. Turn Cooling or power off to quit diagnostics. Diagnostics time out after 20 minutes. All other keys are disabled during diagnostics.

MAIN CONTROL			
COMPONENT	FC CODE	RC CODE	DESCRIPTION
FC Thermistor	00	°F/°C	TEMPERATURE
		OP	OPEN > 88kΩ
		SH	SHORT < 1600Ω
RC Thermistor	01	°F/°C	TEMPERATURE
		OP	OPEN CIRCUIT
		SH	SHORT CIRCUIT
Evaporator Fan Motor	02	00	OFF
		20	2000RPM (8 V)
		23	2300 RPM (9.2 V)
		26	2600 RPM (10.4 V)
		30	3000 RPM (12 V)
Condenser Fan Motor	03	00	OFF
		01	ON (115 V)
		00	OFF; WAITING DELAY
VC Compressor	04	16	ON AT 1600 RPM
		45	ON AT 4500 RPM
Air Door & evap fan on	05	00	AIR DOOR CLOSES
		01	AIR DOOR OPENS
Defrost Heater On	06	00	BI-METAL CLOSED
		01	BI-METAL OPEN
Defrost Option	07	00	DEFAULT-ADAPTIVE
		01	BASIC

PAN CONTROL			
COMPONENT	FC CODE	RC CODE	DESCRIPTION
Lighting	10	00	PAN ACCENT LIGHT
Thermistor	11	°F/°C	TEMPERATURE
		OP	OPEN > 88kΩ
		SH	SHORT < 1600Ω
User selection LED indicator test	12	00	ALL INDICATORS OFF
		01	DELI
		02	PRODUCE
		03	MEAT
Air Door	13	00	AIR DOOR CLOSES
		01	AIR DOOR OPENS

WARNING: IF BI-METAL IS BY-PASSED FOR TESTING (IF APPLICABLE), DO NOT OVERHEAT EVAPORATOR AREA.

SERVICE AND WIRING 36" BOTTOM MOUNT

⚠ WARNING



Electrical Shock Hazard
Disconnect power before servicing.
Replace all parts and panels before operating.
Failure to do so can result in death or electrical shock.

• Normal operating conditions are viewed when the air and temperature controls are at mid-setting, freezer section 0 to 5°F and unit is cycling.

NOTE: Watt and pressure readings will vary and are influenced by the existing condition of the appliance, such as iced-up evaporator, condition of condenser, defrost cycle, pull-down time and customer use.

PERFORMANCE DATA (NORMAL OPERATION CONDITIONS)			
AMB	WATTS	SYSTEM PRESSURE (PSIG)	
		HIGH SIDE	LOW SIDE
70°	140±20	95±20	-7 TO 3
90°	150±20	135±20	-4 TO 3
110°	170±20	185±20	-2 TO 4

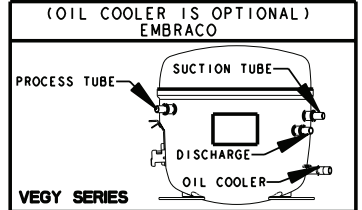

SERVICE INFORMATION (W10234139 B)

1. COMPRESSOR SUCTION AND PROCESS STUBS CAN NOT BE INTERCHANGED.
2. REFRIGERANT CHARGE MUST BE APPLIED TO HIGH SIDE ONLY.
3. NOTE: ICE MAKER CYCLE MUST BE INITIATED ELECTRICALLY. DO NOT TRY TO MANUALLY START CYCLE.
4. SERVICE DEFROST BIMETALS - 50° F OPEN.
5. PART NUMBER CAN BE FOUND ON THE COMPONENT.

SERVICEABLE ELECTRICAL PARTS MATRIX COMPONENTS

SERVICEABLE PARTS	Part No.	Watt/Res.	SERVICEABLE PARTS	Part No.	Watt/Res.
COMPRESSOR	2223801	70-130W @120 VAC	CONDENSER FAN MOTOR	2188875	3±1W@120 VAC
RUN WINDINGS	*	6.4Ω	EVAPORATOR FAN MOTOR	2259385	2-5W@12 VDC
START WINDINGS	*	6.4Ω	DEFROST BI-METAL	2321803	
INVERTER ASSY	W10133449	Supply Voltage 120 VAC	ICEMAKER OPTICS EMITTER	W10193840	
THERMISTOR (RC & FC)	2188820	NTC 2.7kΩ@25°C 23kΩ@0F, 7.6kΩ@37F	ICEMAKER OPTICS RECEIVER	W10193666	
AIR Baffle ASSY RC & ICC	2220377	12 VDC @ 300 pps, Blue to White & Red to Yellow both 415±45Ω	COVER ASSY- CRISPER, 36 BM	W10203635	14 VDC INPUT
MAIN CONTROL BOARD (GEMINI FLASH)	W10200659	Supply Voltage 14 VDC	FILL TUBE HEATER	2221240	4.2W±5% (3.4kΩ)@120 VAC
MAIN CONTROL BOARD POWER SUPPLY	W10120824	120 VAC PRIMARY 14 VDC SECONDARY	CONTROL-ELEK(PAN)	W10184634	14 VDC INPUT
DEFROST HEATER	2268393	581 W (24.7Ω)@120 VAC			
CONTROL BOX ASSY (TOP OF RC)	W10196640				

ELECTRONIC CONTROL FEATURES

The electronic control in this appliance maintains the temperature, controlling the operation and speed of the compressor as well as the evaporator fan motor. The Adaptive Defrost Control (ADC) portion of the electronic control utilizes "Pulsed Defrost" technology to perform defrost function. (See troubleshooting tips for more information).

1. Pulsed Defrost Heat - During the defrost cycle the heater is energized continuously for the first 7 minutes. It is then cycled off for 60 seconds and on for 120 seconds. The on/off cycle is repeated until the bi-metal opens or the maximum defrost time (33 minutes) is reached.

SERVICE DIAGNOSTICS MODE

Product must be on to enter service diagnostic mode. Press the RC Temp increase key and the Cooling On/Off key simultaneously for 3 seconds. The 2-digit FC display shows the diagnostic step. Steps 00 through 07 are for input/output circuits of the main control board. Steps 10 through 13 are for the pan control board. The FC+ and FC- buttons switch between control boards. The Set to Recommended and °F/°C buttons switch between steps. The 2-digit RC display shows the status for input circuits or the option for output circuits. The RC+ and RC- buttons switch between options. Turn Cooling or power off to quit diagnostics. Diagnostics time out after 20 minutes. All other keys are disabled during diagnostics.

MAIN CONTROL			
COMPONENT	FC CODE	RC CODE	DESCRIPTION
FC Thermistor	00	°F/°C	TEMPERATURE
		OP	OPEN > 88kΩ
		SH	SHORT < 1600Ω
RC Thermistor	01	°F/°C	TEMPERATURE
		OP	OPEN CIRCUIT
		SH	SHORT CIRCUIT
Evaporator Fan Motor	02	00	OFF
		20	2000RPM (8 V)
		23	2300 RPM (9.2 V)
		26	2600 RPM (10.4 V)
Condenser Fan Motor	03	00	OFF
		01	ON (115 V)
		04	OFF; WAITING DELAY
VC Compressor	04	16	ON AT 1600 RPM
		45	ON AT 4500 RPM
		00	AIR DOOR CLOSES
Air Door & evap fan on	05	01	AIR DOOR OPENS
		00	BI-METAL CLOSED
Defrost Heater On	06	01	BI-METAL OPEN
		00	DEFAULT-ADAPTIVE
Defrost Option	07	00	DEFAULT-ADAPTIVE
		01	BASIC

PAN CONTROL			
COMPONENT	FC CODE	RC CODE	DESCRIPTION
Lighting	10	00	PAN ACCENT LIGHT
Thermistor	11	°F/°C	TEMPERATURE
		OP	OPEN > 88kΩ
		SH	SHORT < 1600Ω
User selection LED indicator test	12	00	ALL INDICATORS OFF
		01	DELI
		02	PRODUCE
		03	MEAT
Air Door	13	04	QUICK CHILL
		00	AIR DOOR CLOSES
		01	AIR DOOR OPENS

WARNING: IF BI-METAL IS BY-PASSED FOR TESTING (IF APPLICABLE), DO NOT OVERHEAT EVAPORATOR AREA.

SERVICE AND WIRING 42" FRENCH DOOR

⚠️ WARNING



Electrical Shock Hazard
 Disconnect power before servicing.
 Replace all parts and panels before operating.
 Failure to do so can result in death or electrical shock.

• Normal operating conditions are viewed when the air and temperature controls are at mid-setting, freezer section 0 to 5°F and unit is cycling.

NOTE: Watt and pressure readings will vary and are influenced by the existing condition of the appliance, such as iced-up evaporator, condition of condenser, defrost cycle, pull-down time and customer use.

PERFORMANCE DATA (NORMAL OPERATION CONDITIONS)			
AMB	WATTS	SYSTEM PRESSURE (PSIG)	
		HIGH SIDE	LOW SIDE
70°	140±20	95±20	-7 TO 3
90°	150±20	135±20	-4 TO 3
110°	170±20	185±20	-2 TO 4

(COIL COOLER IS OPTIONAL)
 EMBRACO

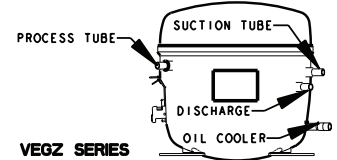

SERVICE INFORMATION (W10234140 B)

1. COMPRESSOR SUCTION AND PROCESS STUBS CAN NOT BE INTERCHANGED.
2. REFRIGERANT CHARGE MUST BE APPLIED TO HIGH SIDE ONLY.
3. NOTE: ICE MAKER CYCLE MUST BE INITIATED ELECTRICALLY. DO NOT TRY TO MANUALLY START CYCLE.
4. SERVICE DEFROST BIMETALS - 50° F OPEN.
5. PART NUMBER CAN BE FOUND ON THE COMPONENT.

SERVICEABLE ELECTRICAL PARTS MATRIX COMPONENTS

SERVICEABLE PARTS	Part No.	Watt/Res.	SERVICEABLE PARTS	Part No.	Watt/Res.
COMPRESSOR	W10173296	70-130W @120 VAC	CONDENSER FAN MOTOR	2188875	3±1W@120 VAC
RUN WINDINGS	*	6.4Ω	EVAPORATOR FAN MOTOR	2259385	2-5W@12 VDC
START WINDINGS	*	6.4Ω	DEFROST BI-METAL	2321803	
INVERTER ASSY	W10133449	Supply Voltage 120 VAC	FILL TUBE HEATER	2221240	4.2W±5% (3.4kΩ)@120 VAC
THERMISTOR (RC & FC)	2188820	NTC 2.7kΩ@25°C 23kΩ@0°F, 7.6kΩ@37°F	FLIPPER MULLION ASSY	W10188592	5W±7.5% (115Ω)@24 VDC
AIR BAFFLE ASSY RC & ICC	2220377	12 VDC @ 300 pps, Blue to White & Red to Yellow both 415±45Ω	COVER ASSY-CRISPER, RH	W10203644	
MAIN CONTROL BOARD (GEMINI FLASH)	W10200659	Supply Voltage 14 VDC	COVER ASSY-CRISPER, LH	W10194724	
CONTROL - ELEK	W10184634 (X2)	Supply Voltage 14 VDC	MAIN CONTROL BOARD POWER SUPPLY	W10120824	120 VAC PRIMARY 14 VDC SECONDARY
CONTROL BOX ASSY (TOP OF RC)	W10196641		ICEMAKER OPTICS RECEIVER	W10193666	
DEFROST HEATER	W10219166	740 W (19.4Ω)@120 VAC	ICEMAKER OPTICS EMITTER	W10193840	

ELECTRONIC CONTROL FEATURES

The electronic control in this appliance maintains the temperature, controlling the operation and speed of the compressor as well as the evaporator fan motor. The Adaptive Defrost Control (ADC) portion of the electronic control utilizes "Pulsed Defrost" technology to perform defrost function. (See troubleshooting tips for more information)

1. Pulsed Defrost Heat - During the defrost cycle the heater is energized continuously for the first 7 minutes. It is then cycled off for 60 seconds and on for 120 seconds. The on/off cycle is repeated until the bi-metal opens or the maximum defrost time (33 minutes) is reached.

SERVICE DIAGNOSTICS MODE

Product must be on to enter service diagnostic mode. Press the RC Temp increase key and the Cooling On/Off key simultaneously for 3 seconds. The 2-digit FC display shows the diagnostic step. Steps 00 through 07 are for input/output circuits of the main control board. Steps 10 through 13 are for the left bin control board and Steps 20 through 23 for the right bin control board. The FC+ and FC- buttons switch between control boards. The Set to Recommended and °F/°C buttons switch between steps. The 2-digit RC display shows the status for input circuits or the option for output circuits. The RC+ and RC- buttons switch between options. Turn Cooling or power off to quit diagnostics. Diagnostics time out after 20 minutes. All other keys are disabled during diagnostics.

MAIN CONTROL	FC CODE	RC CODE	DESCRIPTION	
			°F/°C	TEMPERATURE
FC THERMISTOR	00	OP	OPEN crkt>88kΩ	
		SH	SHORT crkt<1600Ω	
		SH	SHORT crkt<1600Ω	
RC THERMISTOR	01	OP	OPEN CIRCUIT	
		SH	SHORT CIRCUIT	
		00	OFF	
EVAPORATOR FAN MOTOR	02	20	2000 RPM (8 V)	
		23	2300 RPM (9.2 V)	
		26	2600 RPM (10.4 V)	
		30	3000 RPM (12 V)	
CONDENSER FAN MOTOR	03	00	OFF	
		01	ON (115 V)	
VC COMPRESSOR	04	00	OFF; WAITING DELAY	
		16	ON AT 1600 RPM	
		45	ON AT 4500 RPM	
AIR DOOR & EVAP FAN ON	05	00	AIR DOOR CLOSES	
		01	AIR DOOR OPENS	
DEFROST HEATER ON	06	00	BI-METAL CLOSED	
		01	BI-METAL OPEN	
DEFROST OPTION	07	00	DEFAULT-ADAPTIVE	
		01	BASIC	

BIN CONTROL	FC CODE	RC CODE	DESCRIPTION	
			°F/°C	TEMPERATURE
LEFT BIN	10	00	BIN ACCENT LIGHTS	
		11	TEMPERATURE	
		OP	OPEN crkt>88kΩ	
THERMISTOR	11	SH	SHORT crkt<1600Ω	
		SH	SHORT crkt<1600Ω	
		00	OFF	
USER SELECTION LED INDICATOR TEST	12	00	ALL INDICATORS OFF	
		01	DELI	
		02	PRODUCE	
		03	MEAT	
AIR DOOR	13	00	AIR DOOR CLOSES	
		01	AIR DOOR OPENS	

BIN CONTROL	FC CODE	RC CODE	DESCRIPTION	
			°F/°C	TEMPERATURE
RIGHT BIN	20	00	BIN ACCENT LIGHTS	
		21	TEMPERATURE	
		OP	OPEN crkt>88kΩ	
THERMISTOR	21	SH	SHORT crkt<1600Ω	
		SH	SHORT crkt<1600Ω	
		00	OFF	
USER SELECTION LED INDICATOR TEST	22	00	ALL INDICATORS OFF	
		01	DELI	
		02	PRODUCE	
		03	MEAT	
AIR DOOR	23	00	AIR DOOR CLOSES	
		01	AIR DOOR OPENS	

WARNING: IF BI-METAL IS BY-PASSED FOR TESTING (IF APPLICABLE), DO NOT OVERHEAT EVAPORATOR AREA.

EXAMPLE 42" AND 48" SIDE BY SIDE REFRIGERATOR WIRING DIAGRAM

Always refer to the Diagram shipped with the refrigerator when servicing

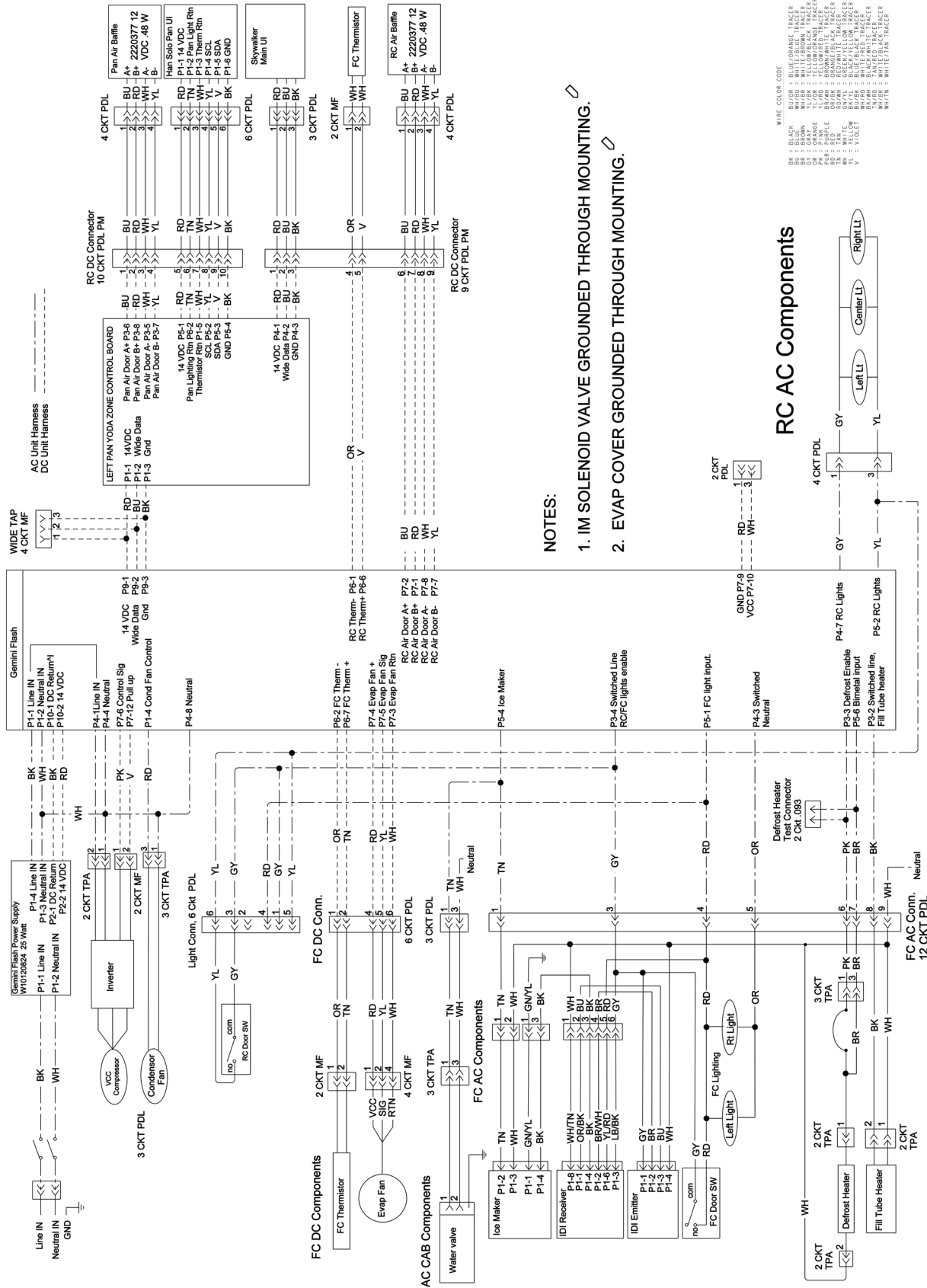

- NOTES:**
1. IM SOLENOID VALVE GROUNDED THROUGH MOUNTING.
 2. EVAP COVER GROUNDED THROUGH MOUNTING.

WIRE COLOR CODE

BK	: BLACK
BU/BR	: BLUE/BRANGE TRACKER
BU	: BLUE
WH/BR	: WHITE/BRANGE TRACKER
WH	: WHITE
OR	: ORANGE
YL/BR	: YELLOW/BRANGE TRACKER
YL	: YELLOW
PK	: PINK
BR	: BROWN
PK/BR	: PINK/BROWN TRACKER
BR	: BROWN
GY	: GREEN
GY/WH	: GREEN/WHITE TRACKER
GY	: GREEN
YL	: YELLOW
V	: VIOLET
WH/BR	: WHITE/BRANGE TRACKER
WH/BR	: WHITE/BRANGE TRACKER

EXAMPLE 42" FRENCH DOOR REFRIGERATOR WIRING DIAGRAM

Always refer to the Diagram shipped with the refrigerator when servicing

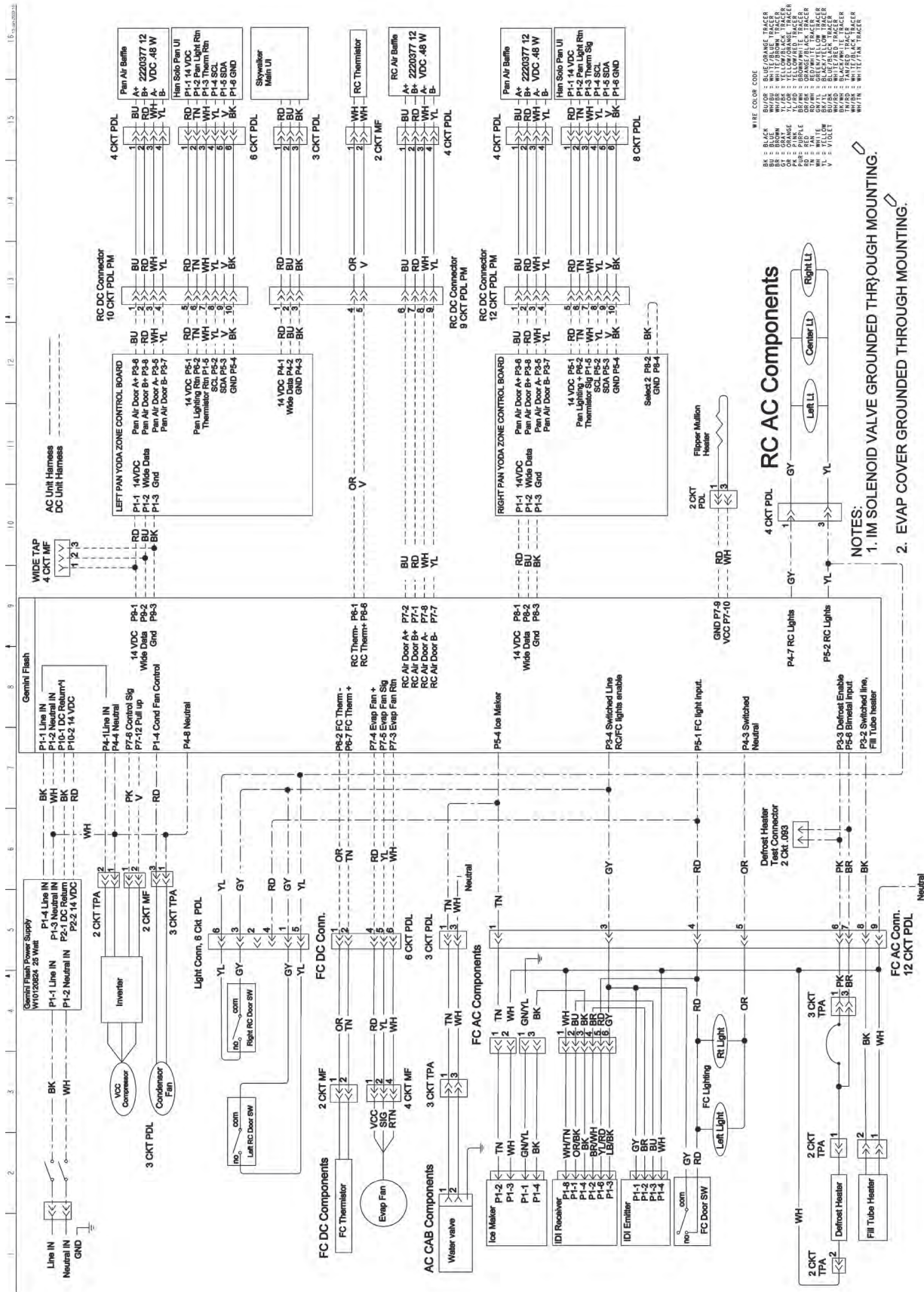

PRODUCT SPECIFICATIONS AND WARRANTY INFORMATION SOURCES

IN THE UNITED STATES:

FOR PRODUCT SPECIFICATIONS AND WARRANTY INFORMATION CALL:

FOR WHIRLPOOL PRODUCTS: 1-800-253-1301

FOR KITCHENAID PRODUCTS: 1-800-422-1230

FOR ROPER PRODUCTS: 1-800-447-6737

FOR TECHNICAL ASSISTANCE WHILE AT THE CUSTOMER'S HOME CALL:

THE TECHNICAL ASSISTANCE LINE: 1-800-832-7174

**HAVE YOUR STORE NUMBER READY TO IDENTIFY YOU AS AN
AUTHORIZED IN-HOME SERVICE PROFESSIONAL**

FOR LITERATURE ORDERS:

PHONE: 1-800-851-4605

FOR TECHNICAL INFORMATION AND SERVICE POINTERS:

www.servicematters.com

IN CANADA:

FOR PRODUCT SPECIFICATIONS AND WARRANTY INFORMATION CALL:

1-800-461-5681

FOR TECHNICAL ASSISTANCE WHILE AT THE CUSTOMER'S HOME CALL:

THE TECHNICAL ASSISTANCE LINE: 1-800-488-4791

**HAVE YOUR STORE NUMBER READY TO IDENTIFY YOU AS AN
AUTHORIZED IN-HOME SERVICE PROFESSIONAL**

