

CERAMIC COOKTOP

MODELS CE901 AND CE901M

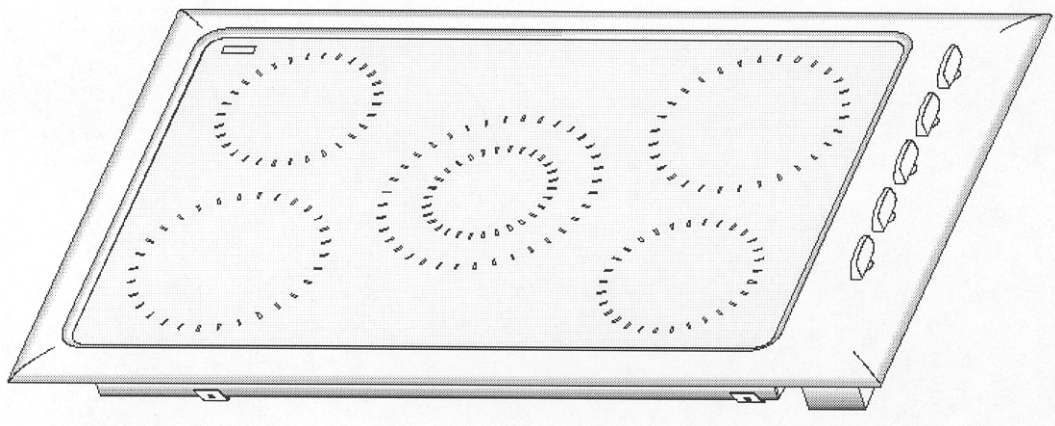

MODELS COVERED BY THIS MANUAL

Fisher and Paykel CE901 Titan Ceramic Cooktop

MODEL			CODE	MARKET	
CE901	SS	FP	88414	US	United States of America/Canada
CE901M	SM	FP	88418	US	United States of America/Canada
CE901M	SM	FP	87815	NZ	New Zealand
CE901M	SM	FP	87825	AU	Australia
CE901	SS	FP	88773	GB, IE	Great Britain, Ireland
CE901M	SM	FP	88774	GB, IE	Great Britain, Ireland

SERVICE ASSISTANCE

USA Toll Free 1 888 9 FNP USA (1 888 936 7872)
Fisher and Paykel Appliances Inc.
27 Hubble, Irvine CA 92618
Website: <http://usa.fisherpaykel.com>

GB Fisher and Paykel Appliances Ltd
Broxell Close, Wedgnock Industrial Estate, Warwick
Warwickshire, CV34 5QF.
Tel 01 926 626700
Fax 01 926 626701

IRELAND C & F Quadrant, Unit 4
40 Cherry Orchard Industrial Estate
Dublin 10
Tel 01 630 5757
Fax 01 630 5706

AUSTRALIA Fisher and Paykel Customer Services
PO Box 798
Cleveland, Queensland 4163
Tel 07 3826 9122
Fax 07 3826 9164
Email: customer.care@fp.com.au

NEW ZEALAND Fisher and Paykel Customer Care
PO Box 58732
Greenmont, Auckland
Tel 0800 FP CARE (0800 372273)
Fax 09 273 0656
Email: customer.care@fp.co.nz

CONTENTS

MODELS COVERED BY THIS MANUAL	3
SERVICE ASSISTANCE	3
1. SERVICING & SAFETY PRECAUTIONS	5
1.1 WARNINGS	5
2. SPECIFICATIONS	6
2.1 DIMENSIONS	6
2.2 COUNTERTOP CUTOUT DIMENSIONS	6
2.3 ELECTRICAL SPECIFICATIONS	7
2.4 LOCATION OF SERIAL NUMBER AND PRODUCT INFORMATION	7
3. SERVICING INSTRUCTIONS	8
3.1 REMOVAL FROM THE COUNTERTOP	8
3.2 REPLACING ELEMENTS	9
3.3 REPLACING ENERGY REGULATORS	12
3.4 REPLACING HOT/ON LIGHTS	15
3.5 INTERNAL WIRE RESTRAINT	18
3.6 WIRING DIAGRAM – STANDARD MODELS	20
3.7 WIRING DIAGRAM – IRIDIUM MODELS	21

1. SERVICING & SAFETY PRECAUTIONS

1.1 WARNINGS

The following icons will appear in the left margin when the precaution they illustrate is particularly relevant. Safe and tidy work practices must be adhered to at all times when servicing appliances.



Electrical shock hazard. Isolate the cooktop from the electrical supply before servicing. Failure to do so could result in death or electric shock.



Cut hazard. Take care when handling as the stainless steel may have sharp edges. Failure to do so could result in injury or cuts.

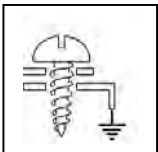

Make sure all the screws and covers are refitted after servicing, as some are vital to maintaining the earth path.

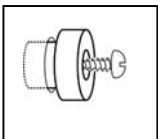

The plastic standoffs that hold the main cover are required to maintain safe clearances between the cooktop and the surrounding joinery. Ensure they are always refitted.



Wiring is to be gathered and taped so it cannot reach the element cases. The tape is to be a glass cloth type, rated to at least 200°C. For USA the wiring in the control box must also be gathered and taped so it cannot reach live terminals and the tape must be UL rated for 200°C. See section 3.5 Internal wire restraint.

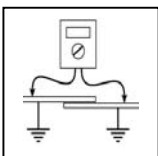

Carry out an earth continuity test between the earth conductor and exposed metal parts.

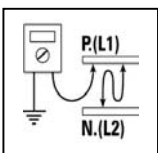

Carry out a high potential electric strength test (megger test) with the phase and neutral conductors (L1 and L2 in the US) connected together to protect the electronics.



The CE901 cooktop contains electronic components that can be damaged by electrostatic discharge from your fingers. A grounded wrist strap must be worn when handling electronic components or wiring connected to electronic components.

2. SPECIFICATIONS

2.1 DIMENSIONS

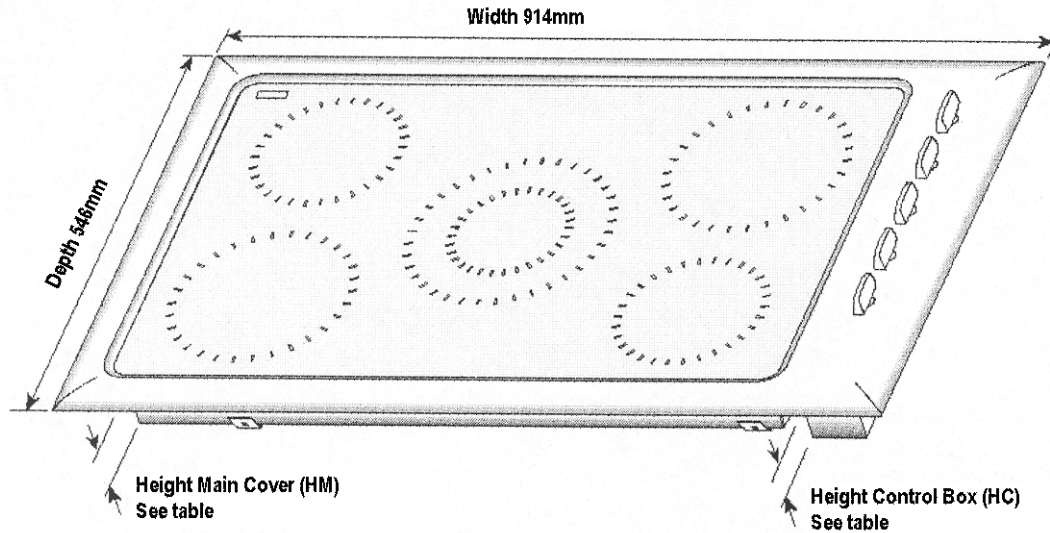

Market	Width		Depth		Height HM		Height HC	
	mm	inch	mm	inch	mm	inch	mm	inch
US	914	36	546	21 1/2	80	3 1/8	80	3 1/8
AU, NZ, GB, IE	914	36	546	21 1/2	70	2 3/4	83	3 1/4

2.2 COUNTERTOP CUTOUT DIMENSIONS

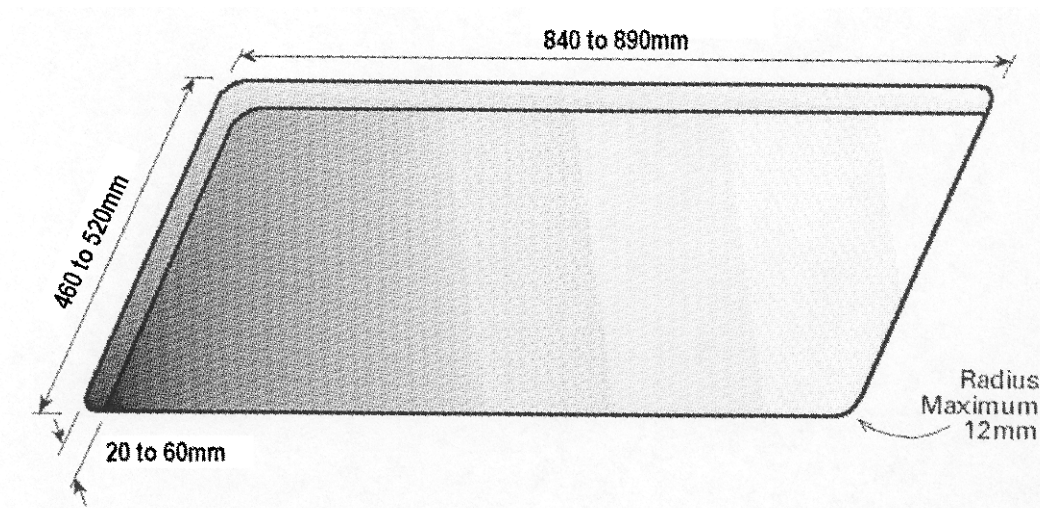

2.3 ELECTRICAL SPECIFICATIONS

Market	Voltage	Frequency Hz	Power Kw	Current Max. Amps	Approvals
US	240	60	8.5	35.4	UL858
	208	60	6.4	31	
NZ, GB, IE	230	50	7.8	34	IEC 60335
AU	240	50	8.2	35.4	IEC 60335

ELEMENTS

Position	Size		Power Kw	F&P Part Number	
	mm	inches		CE901	CE901M
Right Rear	200	8	1800	355747	355747
Left Rear	165	6 1/2	1200	355746	355746
Centre	255	10	2500	531148	531148
Right Front	165	6 1/2	1200	355746	531143
Left Front	200	8	1800	355747	355747

2.4 LOCATION OF SERIAL NUMBER AND PRODUCT INFORMATION

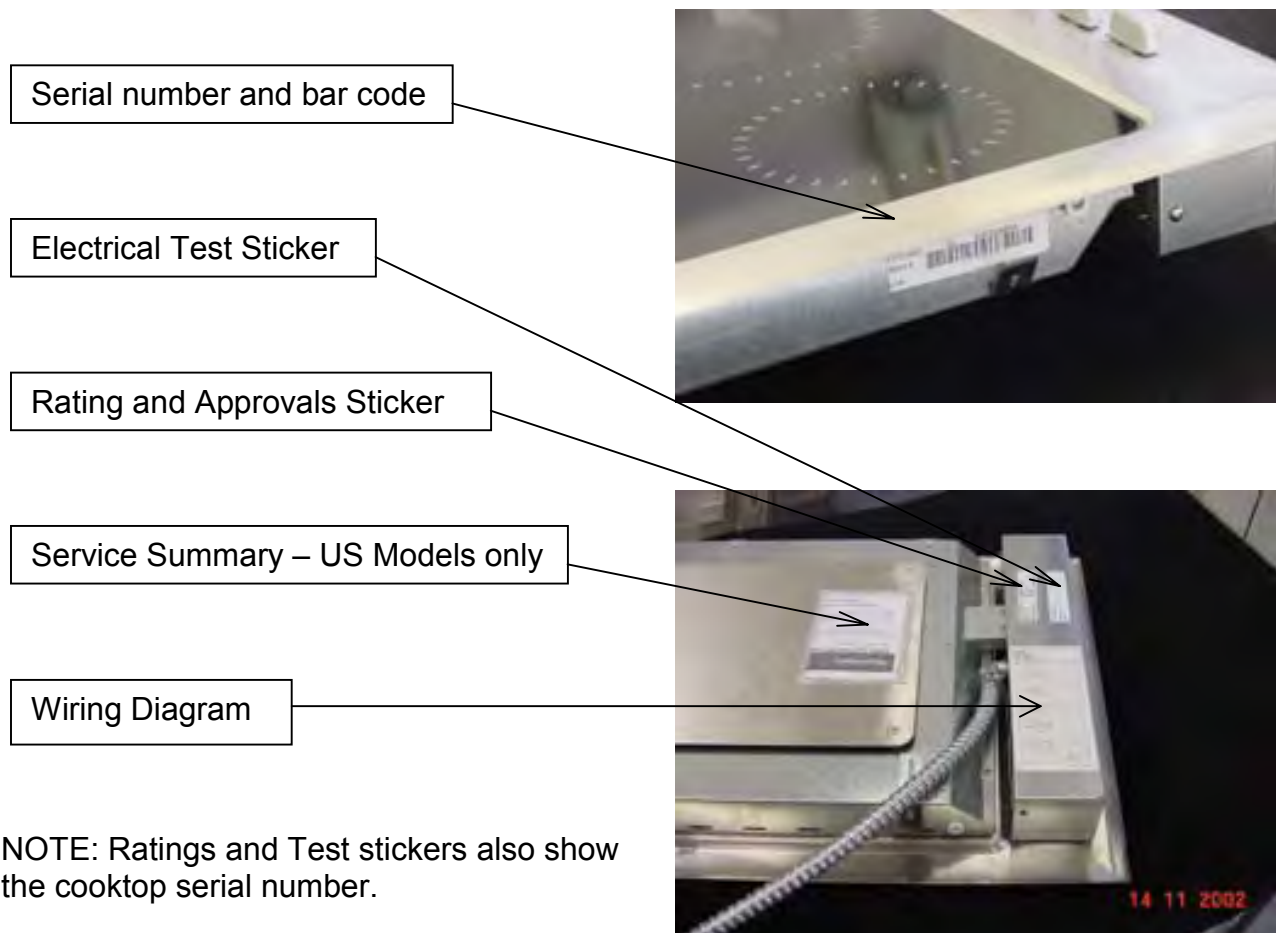

3. SERVICING INSTRUCTIONS

3.1 REMOVAL FROM THE COUNTERTOP



Isolate the unit from the power supply by turning off the main switch and removing the fuse or fuses where more than one phase is used. Check that the circuit is dead by attempting to operate the appliance.

- ❑ Remove the clamping brackets from the underside of the cooktop. Take note of their positions.



- ❑ Place a protective covering on the countertop adjacent to the cooktop or another surface suitable for placing the cooktop on. Check that there is sufficient length of cable / conduit to allow the cooktop to be removed and turned over. In some situations, the cable / conduit may need to be disconnected with the cooktop in the counter top. On models sold in AU, NZ, GB and IE the cable can be disconnected at the cooktop terminal block.



Push the unit up from below and place blocks under the corners of the hob. This will allow the cooktop to be lifted out from above.



- ❑ In some situations it may not be possible to reach the underside of the cooktop to push it up. In this case, use a smooth edge tool to raise the cooktop at the corners to place the blocks. Take care not to mark the counter top.



- ❑ Lift the cooktop out of the countertop and place it face down on the protective covering.
- ❑ Disconnect the conduit from the junction box (US models) or cable from the cooktop terminal block (AU, NZ, GB and IE). The cooktop is now free to be removed for service.

3.2 REPLACING ELEMENTS



Isolate the cooktop from the power supply and remove it from the countertop as described in 3.1.

- ❑ Remove the three self tapping screws between the main cover and the 45° end panel.



- ❑ Remove the eight screws and plastic standoffs that hold the main cover. US models are fitted with a heat shield which is attached to the main cover. This can remain attached to the cover.



Disconnect the wiring from the element to be replaced, taking note of the terminal positions.

- ❑ Remove the element screws from the case of the element to be replaced. Withdraw the bushes from the holes in the supporting cross-member(s). Note that the screw holes in the element case are numbered. See the table on page 10.



- ❑ Remove the screws that attach the cross-member(s) to the cooktop frame. The cross-member(s) will ride up on the element springs.

- ❑ Lift up the cross-member as required to allow the removal of the element springs and the element body. Unless it is the dual element being replaced, there will be another element still attached to the cross-member. Try to minimise the movement and handling of the remaining element as the insulation material is easily damaged.



- ❑ Replace the element. Position the new element as near as possible to the original location and orientation.

- ❑ Sit the cross-member(s) back in position and start the screws into the frame.

- Slide the element springs between the cross-member and element case so they are positioned centrally over the screw holes in the element case and beneath the holes in the cross-member.

Element	Element Case Screw Hole Numbers
Dual Element	6, 30, 42 and 66.
1800W Element	21 and 57.
1200W Element	24 and 60.

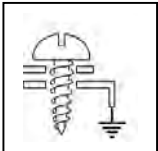

Tighten the screws between the cross-member(s) and the frame. Maximum screw torque 1.3 Nm (11.5 lb-in).

- Refit the element bushes and screws in the correctly numbered holes. Maximum screw torque 1.3 Nm (11.5 lb-in). Make sure that the bush seats squarely on the element case surface and that the spring does not get caught between the bush and the element case.

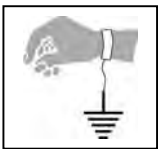

Reconnect the element wiring and check that the wiring is restrained so that it cannot contact the element cases or sheet metal edges. The wiring must be taped as shown in 3.5, using a glass cloth tape rated for at least 200°C. For US models, this tape must be UL rated for 200°C (F&P part 556339 TP 3M 69 GLASS CLOTH SI 19x33M).

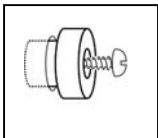

Refit the main cover, screws and standoffs. Maximum screw torque 1.3 Nm (11.5 lb-in).

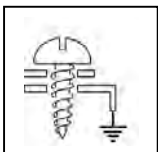

Refit the screws between the main cover and the 45° end panel. Screw torque 1.3 Nm (11.5 lb-in).

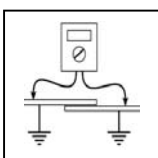

Test the earth continuity between the main cover and the conduit earth conductor (US models) or terminal block earth connection.

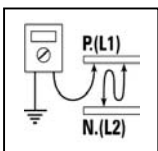

Carryout a high potential electric strength test, (megger test) between the phase and neutral conductors (L1 and L2 in the US) and the earth conductor. Use a jumper lead to connect the phase and neutral conductors together. They must remain connected together during the test to protect the electronic circuitry. Test the cooktop with all the energy regulators set in the HI position. Test potential to be between 500 and 1000 volts. See pictures on the following page.

Conduit Equipped Models (US).

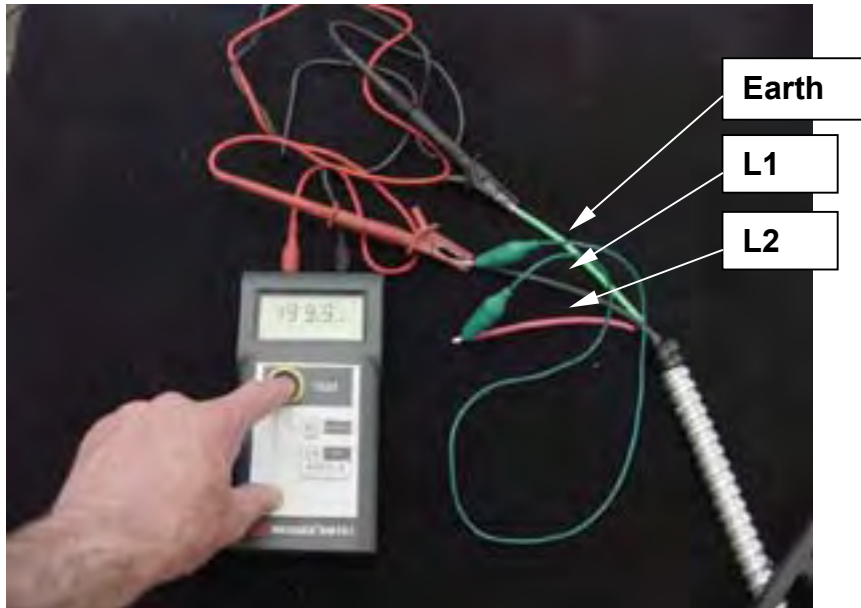

Terminal Block models (AU, NZ, GB and IE).

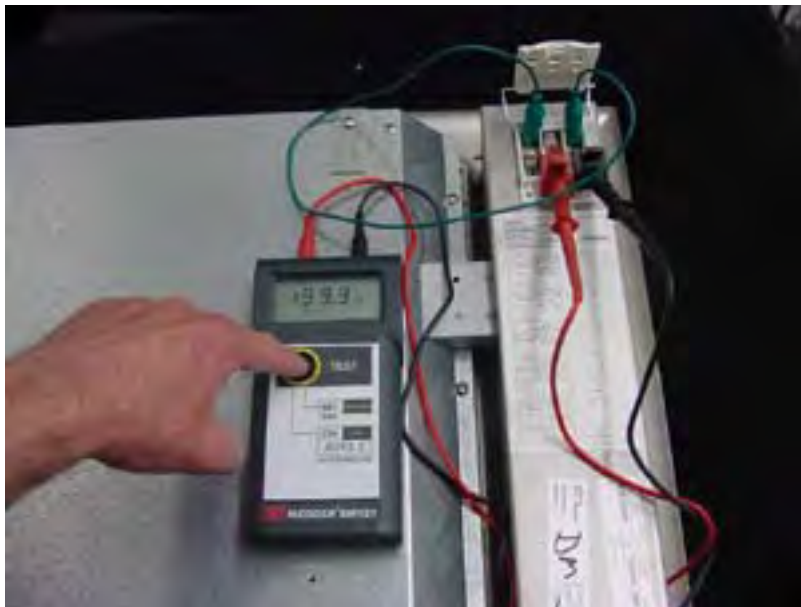

Once back in the counter top and reconnected to the supply, check the function of each element by switching to a medium setting and observing its operation. Look for the cycling of the energy regulator by observing the glow of the element as it heats and cools. Check the operation of the “on” light under the knob.

- Turn to HI and wait for the element to cycle on the temperature limiter.
- Turn the element off and check that the “hot” light is operating. Watch for this to go out as the element cools.

3.3 REPLACING ENERGY REGULATORS



Isolate the cooktop from the power supply and remove it from the countertop as described in 3.1.

- ❑ Remove the energy regulator knobs and support the cooktop so that it is not resting on the energy regulator shafts.
- ❑ Remove the eight screws and plastic standoffs that hold the main cover. US models are fitted with a heat shield which is attached to the main cover. This can remain attached to the cover.
- ❑ Remove the three screws that retain the 45° end cover and remove the cover.
- ❑ Remove the four screws that retain the regulator box cover and remove the cover.
- ❑ Models in Aust, NZ, GB and IE, will have wires attached to the inside of the cover through the terminal block. These can remain attached during this procedure.
- ❑ On US models, remove the tape wraps that hold the wiring to the wire restraint rod in the regulator box.
- ❑ Remove the two screws that retain the wiring duct (raceway) cover. Remove the cover. The cover part number and name is, 531180 Bracket cover wire clamp CE901.

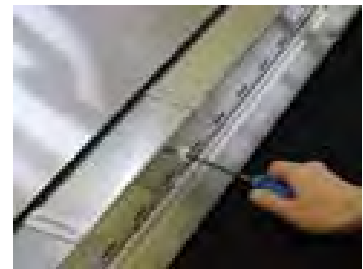

- ❑ Remove the two screws that hold the duct (raceway) to the frame.



Remove the wiring from the regulator that is to be replaced, taking note of the position of each wire.

- ❑ Remove the four fine thread screws that retain the regulator mounting panel.



- ❑ Lift the regulator mounting panel straight up until the regulator shafts are clear of the light bezels. Once the shafts are clear, the regulator panel can be tipped slightly to allow access to the nuts.



- ❑ There are seals between each light bezel and regulator boss. These may come out on the shaft. Place the seals back in the bezels as soon as possible so they are not lost. The seal part number and name is 531159 Seal bezel.
- ❑ Replace the energy regulator, taking note of its orientation. Maximum nut torque 0.5 Nm (4.4 lb-in).
- ❑ Lower the regulator panel back into position. Make sure that the bezel seals stay in position and are not damaged by the regulator shafts. Check that the LED wires are not trapped under the panel or damaged by sharp edges.

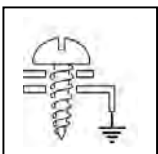

Refit the four fine thread screws that retain the regulator mounting panel. Some downward pressure will be required to compress the bezel seals and line up the screw holes. Screw torque 1.3 Nm (11.5 lb-in).

- ❑ Lift the cooktop slightly, refit the knobs and check that they turn freely and are clear of the hob surface. Check the push to turn function on US models. Over tightening of the energy regulator nut may cause the shaft to bind.

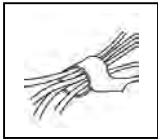

Refit the wiring to the regulator(s). On US models, the wiring in the regulator box must be restrained so it cannot contact live terminals of other circuits. The wiring is to be bunched and taped to the wiring restraint rod with glass cloth insulation tape as shown in 3.5. On US models this tape must be UL rated for 200°C. (F&P part 556339 TP 3M 69 GLASS CLOTH SI 19x33M).



Refit the screws that hold the raceway to the frame. Screw torque 1.3 Nm (11.5 lb-in).
Refit the raceway cover. Screw torque 1.3 Nm (11.5 lb-in).
Refit the terminal box cover. Screw torque 1.3 Nm (11.5 lb-in).
Refit the 45° end cover. Screw torque 1.3 Nm (11.5 lb-in).

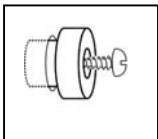

Refit the main cover, screws and standoffs. Maximum screw torque 1.3 Nm (11.5 lb-in).

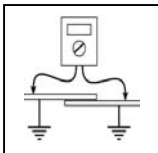

Test the earth continuity between the main cover, raceway cover, regulator box cover and the conduit earth conductor (US models) or terminal block earth connection.

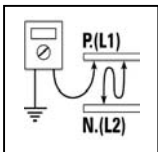

Carryout a high potential electric strength test, (megger test) between the phase and neutral conductors (L1 and L2 in the US) and the earth conductor. Use a jumper lead to connect the phase and neutral conductors together. They must remain connected together during the test to protect the electronic circuitry. Test the cooktop with all the energy regulators set in the HI position. Test potential to be between 500 and 1000 volts. See pictures page 11.



Once back in the counter top and reconnected to the supply, check the function of each element by switching to a medium setting and observing its operation. Look for the cycling of the energy regulator by observing the glow of the element as it heats and cools. Check the operation of the “on” light under the knob.

- Turn to HI and wait for the element to cycle on the temperature limiter.
- Turn the element off and check that the “hot” light is operating. Watch for this to go out as the element cools.

3.4 REPLACING HOT/ON LIGHTS



Isolate the cooktop from the power supply and remove it from the countertop as described in 3.1.

- ❑ Remove the four screws that retain the regulator box cover and remove the cover.



- ❑ Models in Aust, NZ, GB and IE, will have wires attached to the inside of the cover through the terminal block. These can remain attached during this procedure.
- ❑ On US models, remove the tape wraps that hold the wiring to the wire restraint rod in the regulator box.



The PCB has five identical circuits for controlling the “hot” and on lights. At this stage you can confirm that it is the light that is faulty rather than the PCB by swapping the board connector for a malfunctioning light with one that is operating correctly. Refit the regulator box cover, turn the cooktop over and reconnect the power supply. Operate the cooktop only briefly to check the lights as it will need to cool before servicing can continue. Do not leave the cooktop unattended. Determine from this test if it is the light or the control circuit that is faulty.



Disconnect the power supply immediately following the test and allow the cooktop to cool before turning it over again.

- ❑ Remove the three self tapping screws between the main cover and the 45° end panel.
- ❑ Remove the regulator box cover.
- ❑ Remove the eight screws and plastic standoffs that hold the main cover. US models are fitted with a heat shield which is attached to the main cover. This can remain attached to the cover.

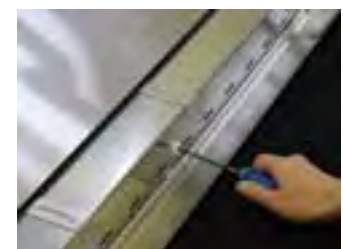

- If the light is faulty, remove the two screws that retain the wiring duct (raceway) cover. Remove the cover. The cover part number and name is 531180 Bracket cover wire clamp CE901.
- Remove the wiring tape wraps as required to free the white PTFE coated hot light switch wire between the faulty LED light harness plug and the element.

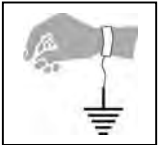

Remove the harness plug from the PCB. Disconnect the hot light switch wire from the element and disconnect the on light switch wire from the pilot terminal on the energy regulator.

- Remove the LEDs from the light bezel by pushing the plastic hooks aside with a fine screw driver and maneuvering the LED wires out. It may be necessary to remove the PCB mounting screws and gently move the PCB to one side to improve access. The other harness plugs can remain in place.
- The LED harnesses are supplied complete. There are two short and three long harnesses per cooktop. The part names and numbers are as follows:

Iridium Short	531162 Harness LED Short White CE901M
Iridium Long	531163 Harness LED Long White CE901M
Standard Short	531104 Harness LED Short CE901
Standard Long	531105 Harness LED Long CE901

- Push the new harnesses LEDs into the light bezel with its head firmly against the end of its cavity. Take care that the wire insulation is not damaged during this operation. Check that the LED wires are trapped by the plastic hooks.



Reconnect the harness wires to the element and the energy regulator. Refit the harness plug to the PCB.



Replace the wiring tape wraps. The wiring must be restrained so that it cannot contact the element cases or sheet metal edges. The wiring must be taped as shown in 3.5, using a glass cloth tape rated for at least 200°C. For US models, this tape must be UL rated for 200°C (F&P part 556339 TP 3M 69 GLASS CLOTH SI 19x33M).



If the control circuit is faulty, remove the harness plugs from the edge of the PCB and remove the two screws that retain the PCB.

Replace the PCB. Part number and name is, 531094 Indicator PCB assy. Screw torque 1.3 Nm (11.5 lb-in).

- On US models, the wiring in the regulator box must be restrained so it cannot contact live terminals of other circuits. The wiring is to be bunched and taped to the wiring restraint rod with glass cloth insulation tape as shown in 3.5.

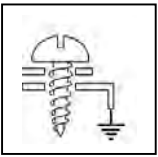

Refit the raceway cover. Screw torque 1.3 Nm (11.5 lb-in).
 Refit the terminal box cover. Screw torque 1.3 Nm (11.5 lb-in).
 Refit the 45° end cover. Screw torque 1.3 Nm (11.5 lb-in).

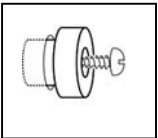

Refit the main cover, screws and standoffs. Maximum screw torque 1.3 Nm (11.5 lb-in).

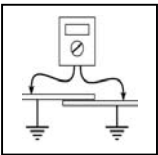

Test the earth continuity between the main cover, raceway cover, regulator box cover and the conduit earth conductor (US models) or terminal block earth connection.

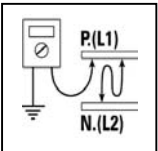

Carryout a high potential electric strength test, (megger test) between the phase and neutral conductors (L1 and L2 in the US) and the earth conductor. Use a jumper lead to connect the phase and neutral conductors together. They must remain connected together during the test to protect the electronic circuitry. Test the cooktop with all the energy regulators set in the HI position. Test potential to be between 500 and 1000 volts. See pictures page 11.



Once back in the counter top and reconnected to the supply, check the function of each element by switching to a medium setting and observing its operation. Look for the cycling of the energy regulator by observing the glow of the element as it heats and cools. Check the operation of the “on” light under the knob.

- Turn to HI and wait for the element to cycle on the temperature limiter.
- Turn the element off and check that the “hot” light is operating. Watch for this to go out as the element cools.

3.5 INTERNAL WIRE RESTRAINT

– Use 200°C rated glass cloth tape (F&P part 556339 TP 3M 69 GLASS CLOTH SI 19x33M).

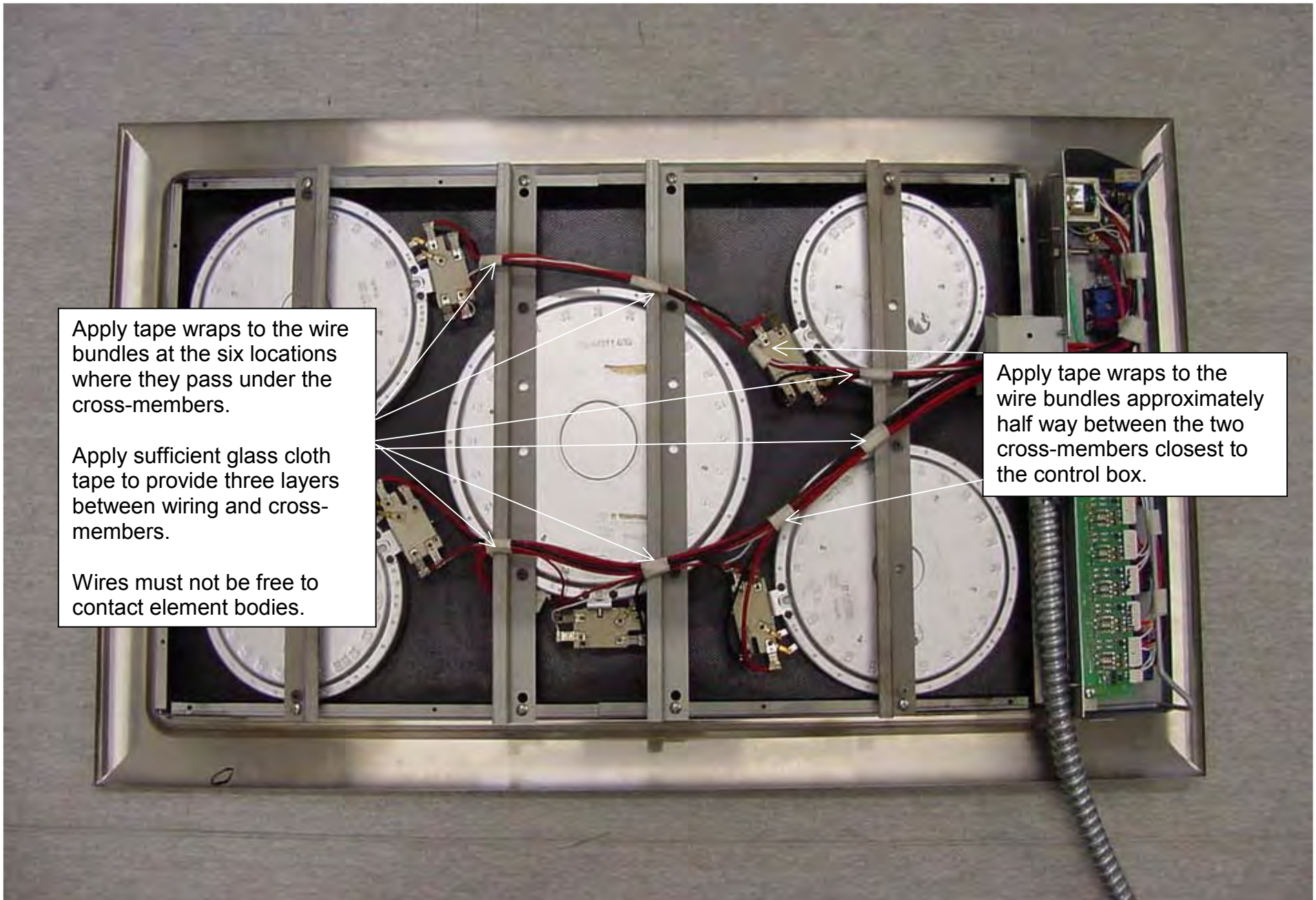

US Models only.

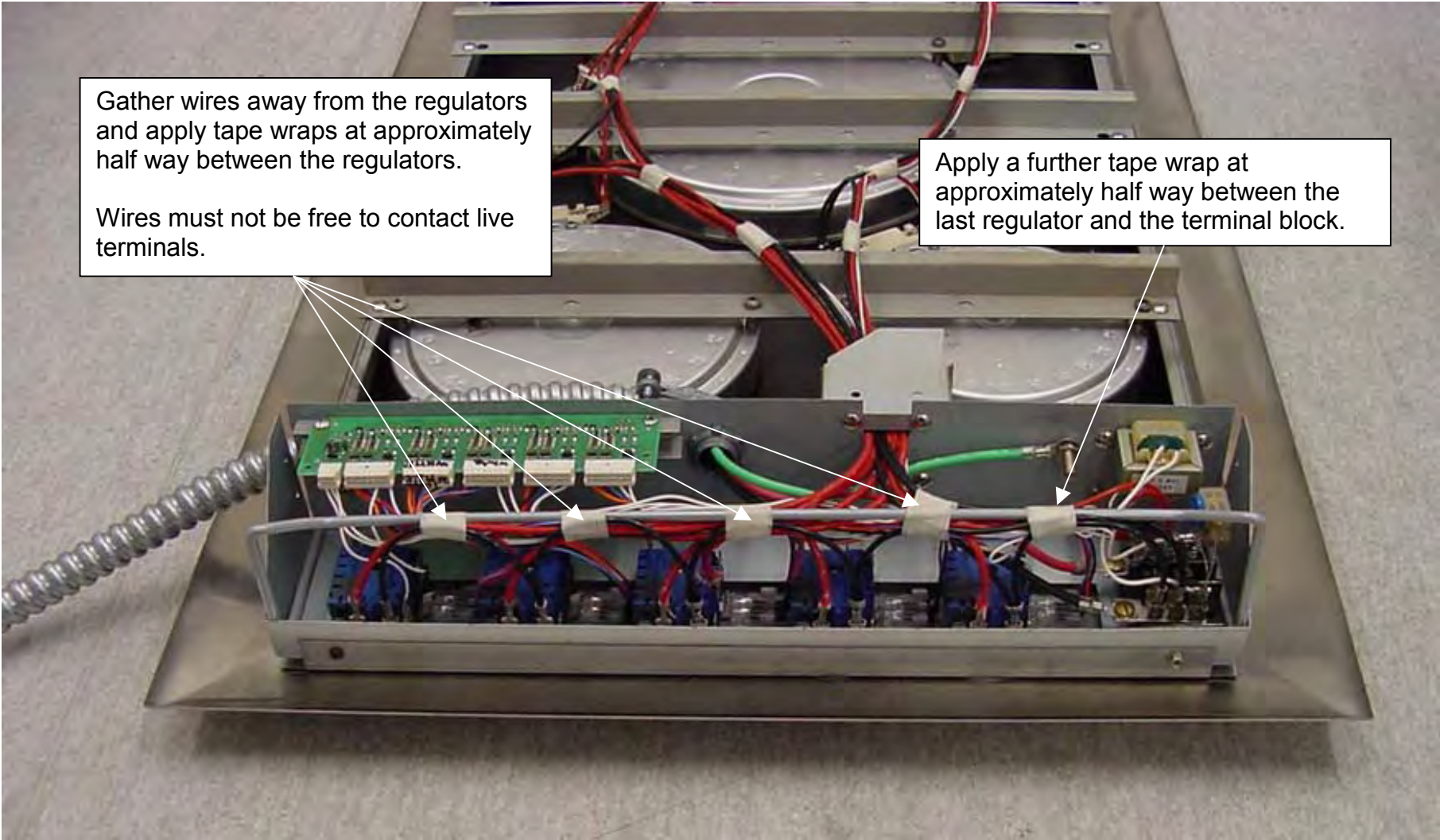

Gather wires away from the regulators and apply tape wraps at approximately half way between the regulators.

Wires must not be free to contact live terminals.

Apply a further tape wrap at approximately half way between the last regulator and the terminal block.

3.6 WIRING DIAGRAM – STANDARD MODELS

CE901 CERAMIC COOKTOP

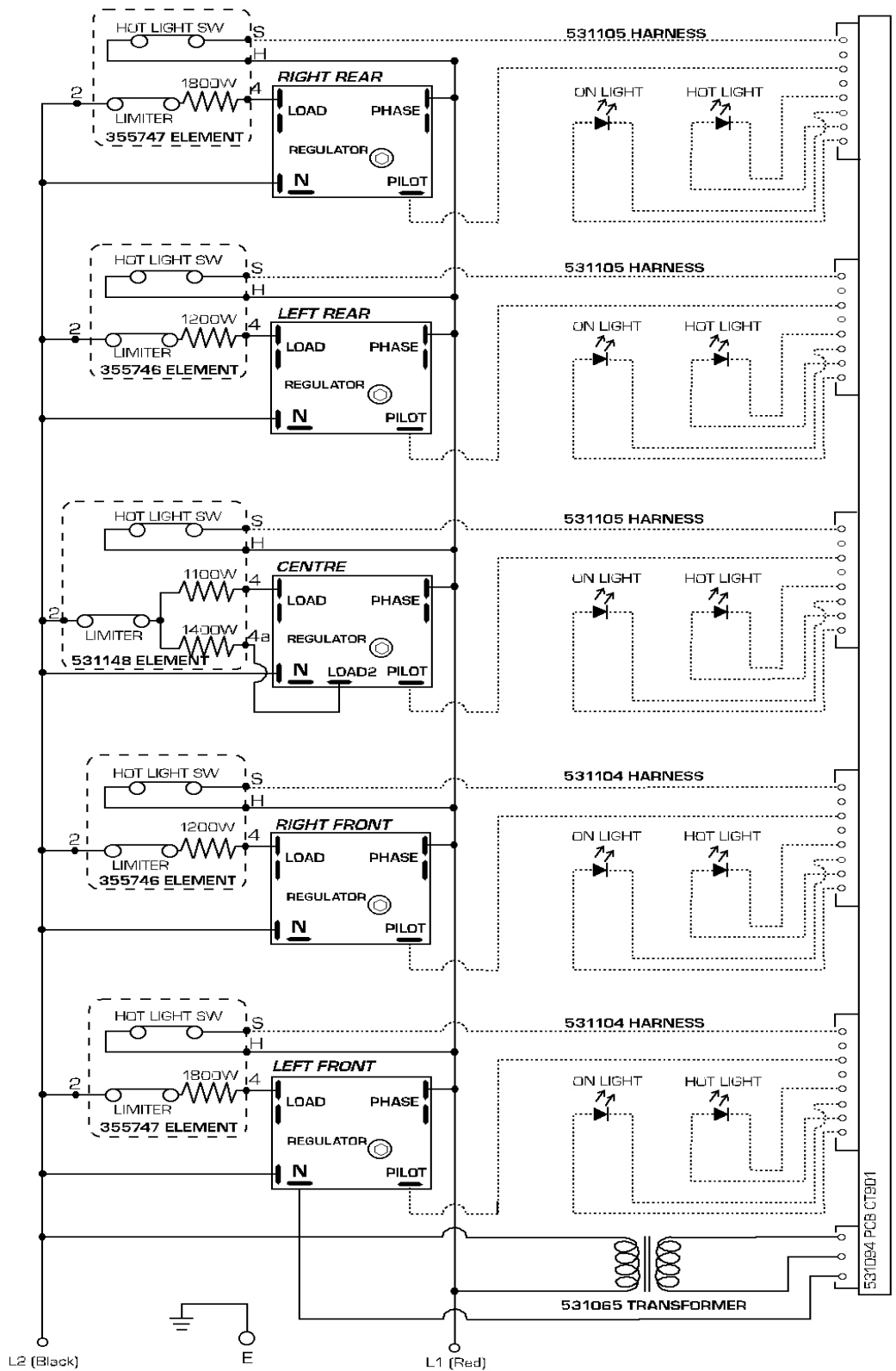

531123B LABEL WIRING COOKTOP CE901

3.7 WIRING DIAGRAM – IRIIDIUM MODELS

CE901M CERAMIC COOKTOP

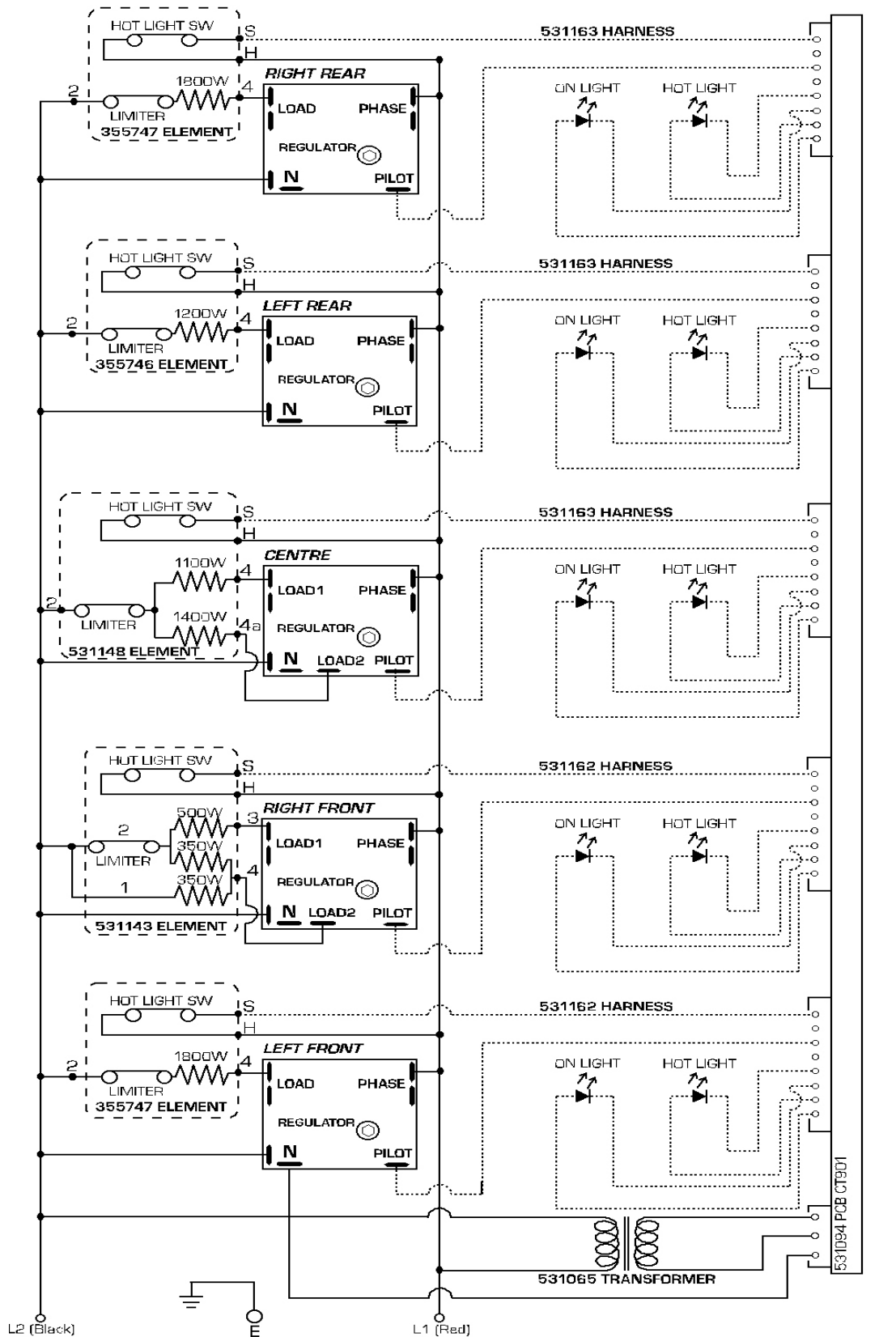

531169B LABEL WIRING COOKTOP CE901M