

KitchenAid

TECHNICAL EDUCATION

15" & 18" AUTOMATIC ICE MAKERS



**KUIS155H,
KUIA15NRH, KUIA15NLH,
KUIA15RRL, KUIA15PLL,
KUIS15NRH, KUIS15PRH**



**KUIS185J,
KUIA18NNJ, KUIA18PNL,
KUIS18NNJ, KUIS18PNJ,
KUIV18NM**

JOB AID 4317339

FORWARD

This KitchenAid Job Aid “15” & 18” Automatic Ice Makers” (Part No. 4317339), provides the technician with information on the installation, operation, and service of the 15” & 18” Automatic Ice Makers. It is to be used as a training Job Aid and Service Manual. For specific information on the model being serviced, refer to the “Use and Care Guide,” or “Tech Sheet” provided with the ice maker.

The Wiring Diagrams and Strip Circuits used in this Job Aid are typical and should be used for training purposes only. Always use the Wiring Diagram supplied with the product when servicing the unit.

GOALS AND OBJECTIVES

The goal of this Job Aid is to provide detailed information that will enable the service technician to properly diagnose malfunctions and repair the KitchenAid 15” & 18” Automatic Ice Makers.

The objectives of this Job Aid are to:

- Understand and follow proper safety precautions.
- Successfully troubleshoot and diagnose malfunctions.
- Successfully perform necessary repairs.
- Successfully return the ice maker to its proper operational status.

WHIRLPOOL CORPORATION assumes no responsibility for any repairs made on our products by anyone other than Authorized Service Technicians.

TABLE OF CONTENTS

| | Page |
|--|------|
| GENERAL | 1-1 |
| Safety First..... | 1-1 |
| KitchenAid Model & Serial Number Designations—Models Prior To 2003..... | 1-3 |
| KitchenAid Model & Serial Number Designations—Models Starting With 2003..... | 1-4 |
| Model & Serial Number Label Location..... | 1-5 |
| Specifications..... | 1-6 |
| KitchenAid Ice Maker Warranty..... | 1-7 |
| INSTALLATION INFORMATION | 2-1 |
| Electrical Supply Requirements..... | 2-1 |
| Water Supply And Drain Connections..... | 2-2 |
| THEORY OF OPERATION | 3-1 |
| Operating Systems..... | 3-1 |
| Operational Cycles..... | 3-4 |
| New Ice Maker Control Board (#6100499)..... | 3-6 |
| Models With Internal Drain Pumps..... | 3-7 |
| COMPONENT ACCESS | 4-1 |
| Component Locations..... | 4-1 |
| Removing The Bin Thermistor, Cutter Grid, Evaporator Thermistor, & Water Distributor..... | 4-2 |
| Removing The Electronic Control Housing Components..... | 4-5 |
| Removing The Water Recirculation Pump..... | 4-7 |
| Removing The Condenser Fan Motor..... | 4-8 |
| Removing The Evaporator..... | 4-11 |
| Removing The Water Inlet Valve..... | 4-15 |
| Removing The Hot Gas Valve & Solenoid..... | 4-16 |
| Removing The Condenser..... | 4-17 |
| Removing The Compressor..... | 4-18 |
| Removing The Internal Drain Pump..... | 4-20 |
| Removing The Ice Maker Door & Gasket (15" Models)..... | 4-21 |
| Removing The Ice Maker Door & Gasket (18" Models)..... | 4-22 |
| COMPONENT TESTING | 5-1 |
| Bin Thermistor..... | 5-1 |
| Evaporator Thermistor..... | 5-1 |
| Cutter Grid..... | 5-2 |
| Cutter Grid Transformer..... | 5-2 |
| Water Recirculation Pump..... | 5-3 |
| Condenser Fan Motor..... | 5-3 |
| Water Inlet Valve Solenoid..... | 5-4 |
| Hot Gas Valve Solenoid..... | 5-4 |
| Compressor, Overload Protector, & Relay..... | 5-5 |
| Pushbutton Switch Assembly..... | 5-7 |

| | Page |
|--|-------------|
| DIAGNOSIS & TROUBLESHOOTING | 6-1 |
| Water And Its Effect On Making Ice | 6-1 |
| Troubleshooting Chart | 6-2 |
| Diagnostic Flow Chart For Ice Maker Control Board #6100499 | 6-5 |
| WIRING DIAGRAM & STRIP CIRCUITS | 7-1 |
| Wiring Diagram | 7-1 |
| Strip Circuits | 7-2 |
| TECH TIPS | 8-1 |
| Cleaning The Ice Maker | 8-1 |
| Cleaning The Evaporator Plate | 8-1 |
| Adjusting The Ice Thickness | 8-3 |

GENERAL SAFETY FIRST

Your safety and the safety of others is very important.

We have provided many important safety messages in this Job Aid and on the appliance. Always read and obey all safety messages.



This is the safety alert symbol.

This symbol alerts you to hazards that can kill or hurt you and others.

All safety messages will follow the safety alert symbol and either the word “DANGER” or “WARNING.” These words mean:

! DANGER

You can be killed or seriously injured if you don't immediately follow instructions.

! WARNING

You can be killed or seriously injured if you don't follow instructions.

All safety messages will tell you what the potential hazard is, tell you how to reduce the chance of injury, and tell you what can happen if the instructions are not followed.

ELECTRICAL POWER SUPPLY & GROUNDING REQUIREMENTS

! WARNING



Electrical Shock Hazard

Disconnect power before servicing.

Replace all parts and panels before operating.

Failure to do so can result in death or electrical shock.

! WARNING



Electrical Shock Hazard

Plug into a grounded 3-prong outlet.

Do not remove ground prong.

Do not use an adapter.

Do not use an extension cord.

Failure to follow these instructions can result in death, fire, or electrical shock.

⚠ WARNING



Electrical Shock Hazard

Connect green ground wire to ground screw.

Failure to do so can result in death or electrical shock.

IMPORTANT

Electrostatic Discharge (ESD) Sensitive Electronics

ESD problems are present everywhere. ESD may damage or weaken the electronic control assembly. The new control assembly may appear to work well after repair is finished, but failure may occur at a later date due to ESD stress.

- Use an antistatic wrist strap. Connect the wrist strap to the green ground connection point, or to an unpainted metal surface in the appliance.

- OR -

- Touch your finger repeatedly to a green ground connection point, or to an unpainted metal surface in the appliance.
- Before removing the part from its package, touch the antistatic bag to a green ground connection point, or to an unpainted metal surface in the appliance.
- Avoid touching electronic parts, or terminal contacts. Handle the electronic control assembly by the edges only.
- When repackaging the failed electronic control assembly in an antistatic bag, observe the previous instructions.

KITCHENAID MODEL & SERIAL NUMBER DESIGNATIONS

MODELS PRIOR TO 2003

MODEL NUMBER

| | | | | | | | | |
|---|----------|-----------|----------|-----------|----------|----------|-----------|----------|
| MODEL NUMBER | K | UI | S | 15 | 5 | H | LS | 0 |
| INTERNATIONAL SALES IND. OR MARKETING CHANNEL IF PRESENT | | | | | | | | |
| PRODUCT GROUP | | | | | | | | |
| K = KITCHENAID | | | | | | | | |
| PRODUCT IDENTIFICATION | | | | | | | | |
| UI = UNDERCOUNTER ICE MAKER | | | | | | | | |
| MERCHANDISING SCHEME | | | | | | | | |
| A = ARCHITECT S = STANDARD | | | | | | | | |
| CAPACITY / SIZE / SERIES / CONFIGURATION | | | | | | | | |
| 15 = 15" WIDE 18 = 18" WIDE | | | | | | | | |
| FEATURES | | | | | | | | |
| 5 = 50 POUNDS | | | | | | | | |
| YEAR OF INTRODUCTION | | | | | | | | |
| H = 1999 | | | | | | | | |
| COLOR CODE | | | | | | | | |
| BL = BLACK; BT = BISCUIT; BS = BLACK & STAINLESS STEEL LS = LEFT SWING STAINLESS ARCHITECT RS = RIGHT SWING STAINLESS ARCHITECT PB = BLACK W/PUMP PW = WHITE W/PUMP WH = WHITE | | | | | | | | |
| ENGINEERING CHANGE (NUMERIC) | | | | | | | | |

SERIAL NUMBER

| | | | | |
|--------------------------------|----------|----------|-----------|--------------|
| SERIAL NUMBER | E | M | 04 | 54321 |
| DIVISION RESPONSIBILITY | | | | |
| E = EVANSVILLE, IN | | | | |
| YEAR OF PRODUCTION | | | | |
| M = 2002, P = 2003 | | | | |
| WEEK OF PRODUCTION | | | | |
| 04 = 4th WEEK | | | | |
| PRODUCT SEQUENCE NUMBER | | | | |

KITCHENAID MODEL & SERIAL NUMBER DESIGNATIONS

MODELS STARTING WITH 2003

MODEL NUMBER

| | | | | | | | | |
|---|---|----|---|----|----|---|---|---|
| MODEL NUMBER | K | UI | S | 15 | NR | H | S | 0 |
| INTERNATIONAL SALES IND. OR MARKETING CHANNEL IF PRESENT | | | | | | | | |
| PRODUCT GROUP K = KITCHENAID | | | | | | | | |
| PRODUCT IDENTIFICATION UI = UNDERCOUNTER ICE MAKER | | | | | | | | |
| MERCHANDISING SCHEME A = ARCHITECT S = STANDARD V = SIGNATURE SERIES | | | | | | | | |
| CAPACITY / SIZE / SERIES / CONFIGURATION 15 = 15" WIDE 18 = 18" WIDE | | | | | | | | |
| FEATURES PR = PUMP, RIGHT HAND DOOR SWING PL = PUMP, LEFT HAND DOOR SWING PN = PUMP, NON-REVERSIBLE DOOR SWING NR = NON-PUMP, RIGHT HAND DOOR SWING NL = NON-PUMP, LEFT HAND DOOR SWING NN = NON-PUMP, NON-REVERSIBLE DOOR SWING | | | | | | | | |
| YEAR OF INTRODUCTION H = 1999, J = 2000, K = 2001, L = 2002, M = 2003 | | | | | | | | |
| COLOR CODE B = BLACK, W = WHITE, S = STAINLESS T = BISCUIT, M = METEORITE | | | | | | | | |
| ENGINEERING CHANGE (NUMERIC) | | | | | | | | |

SERIAL NUMBER

| | | | | |
|--|---|---|----|-------|
| SERIAL NUMBER | E | P | 04 | 54321 |
| DIVISION RESPONSIBILITY E = EVANSVILLE, IN | | | | |
| YEAR OF PRODUCTION P = 2003, R = 2004 | | | | |
| WEEK OF PRODUCTION 04 = 4th WEEK | | | | |
| PRODUCT SEQUENCE NUMBER | | | | |

MODEL & SERIAL NUMBER LABEL LOCATION

The Model/Serial Number label location is shown below.



**Model & Serial
Number Location**

SPECIFICATIONS

AC Power Supply 97 to 127 VAC (rated 115VAC), 60 Hz
 Amperage 3.6 Amps (max)
 Minimum Circuit Capacity 15 Amps
 Ice Production per 24 hours (Approximate)

| Ambient Temperature | Water Temperature 60°F (15°C) |
|---------------------|----------------------------------|
| 70°F (21°C) | 46 lbs (21 kg) |
| 80°F (27°C) | 47 lbs (21 kg) |
| 90°F (32°C) | 40 lbs (18 kg) |
| 100°F (38°C) | 40 lbs (18 kg) |
| 110°F (43°C) | 38 lbs (17 kg) |

Ice Shape 3/4" x 3/4" Square
 Ice Thickness @ Normal Setting (Approximate) 0.32" (8.1 mm)
 Ice Thickness @ Thin Setting (Approximate) 0.28" (7.0 mm)
 Ice Thickness @ Thick Setting (Approximate) 0.39" (9.9 mm)
 Storage Capacity (Approximate) 24 lbs. (10.9 kg)
 Exterior Dimensions (W x D x H) 15" or 18" x 24" x 34" (381 or 457.2 x 609.6 x 863.6 mm)
 Exterior Finish Stainless Steel or Painted Steel
 Net Weight 15" = 94 lbs. (42.6 kg) 18" = 123 lbs. (55.8 kg)
 Cube Thickness Control Thermistor under Evaporator & Control Board Setting
 Harvest Control Thermistor under Evaporator & Control Board Setting
 Bin Ice Level Control Thermistor on side of Bin
 Refrigerant R134a
 Ambient Temperature 55 to 100°F
 Water Pressure 20 to 120 psig
 Water Consumption (Dependent On Water Pressure) 6 to 10 gallons per 4 hours

KITCHENAID ICE MAKER WARRANTY

| | |
|--|---|
| Length of Warranty | KitchenAid will pay: |
| One-Year Full Warranty From date of Purchase | For one year from date of purchase, when this icemaker is operated and maintained according to instructions attached to or furnished with the product, KitchenAid will pay for Factory Specified Parts and Repair Labor to correct defects in materials or workmanship. Service must be provided by a Service Company designated by KitchenAid |
| Five-Year Warranty on Sealed System Second through Fifth Year from Date of Purchase | For five years from the date of purchase, when this icemaker is operated and maintained according to instructions attached or furnished with product, KitchenAid will pay for Factory Specified Parts and labor to correct defects in materials or workmanship on the sealed system (compressor, evaporator, condenser, dryer/strainer, and connecting tubing). |
| KitchenAid Will Not Pay For: | |
| <ul style="list-style-type: none"> A. Installation of your icemaker or damage caused by improper installation or failure to comply with local code requirements. B. Shipping, pickup and delivery, removal or re-installation, as your icemaker is designed to be repaired in the home. C. Damage to the icemaker, floor, cabinets, or plumbing as a result of failure to winterize the product prior to exposure to temperatures below 35 degrees Fahrenheit. D. Service calls to: <ul style="list-style-type: none"> 1. Correct the installation of your KitchenAid icemaker. 2. Instruct you how to use your KitchenAid icemaker. 3. Replace house fuses or to correct house wiring. 4. Perform normal maintenance, including periodic replacement of seals, fittings, etc. E. Repairs when your icemaker is used in other than normal, single-family household use. F. Damage to your icemaker caused by negligence, accident, misuse, fire, flood, acts of God, or use of products, including cleaning products, not approved by KitchenAid or KitchenAid Canada. G. Repairs to parts or system resulting from unauthorized modifications to your icemaker. H. In Canada, travel or transportation expenses for customers who reside in remote areas. I. Replacement parts or repair labor costs for units operated outside the United States and Canada. J. Any labor costs during limited warranty period. K. Deterioration of your icemaker due to normal wear and tear. | |

KitchenAid and KitchenAid Canada Shall Not be Liable for Incidental or Consequential Damages. Any implied warranty of merchantability or fitness for a particular purpose is limited in duration to the length of this warranty. Some states do not allow the exclusion or limitation of incidental or consequential damages, or allow limitations on how long an implied warranty lasts, so these exclusions or limitations may not apply to you. This warranty gives you specific legal rights, and you may also have other rights, which vary, from state to state or province to province.

Outside the United States and Canada, a different warranty may apply. For details, please contact your authorized KitchenAid icemaker dealer.

If you need customer or technical assistance, first see the "Troubleshooting" section of the book. After checking "Troubleshooting", additional help can be found by calling the KitchenAid Customer Interaction Center at 1-800-422-1230, from anywhere in the U.S.A. , and 1-800-807-6777, from anywhere in Canada.

KitchenAid Home Appliances
2000 N M-63
Benton Harbor, MI 49022

®Registered trademark/™Trademark of KitchenAid, U.S.A.
©2002. All rights reserved.

— NOTES —

INSTALLATION INFORMATION

ELECTRICAL SUPPLY REQUIREMENTS

⚠ WARNING



Electrical Shock Hazard

Plug into a grounded 3 prong outlet.

Do not remove ground prong.

Do not use an adapter.

Do not use an extension cord.

Failure to follow these instructions can result in death, fire, or electrical shock.

Before you move the ice maker into its final location, it is important to make sure you have the proper electrical connection:

- A 115 Volt, 60 Hz, AC only 15 ampere electrical supply, properly grounded in accordance with the National Electrical Code and local codes and ordinances, is required.
- It is recommended that a separate circuit, serving only the ice maker, be provided. Use a receptacle which cannot be turned off by a switch or pull chain.

Recommended Grounding Method

For personal safety, this appliance must be grounded. This appliance is equipped with a power supply cord having a 3-prong grounding plug. To minimize possible shock hazard, the cord must be plugged into a mating, 3- prong, grounding-type wall receptacle, grounded in accordance with the National Electrical Code and local codes and ordinances. If a mating wall receptacle is not available, it is the personal responsibility of the customer to have a properly grounded, 3-prong wall receptacle installed by a qualified electrician.

WATER SUPPLY AND DRAIN CONNECTIONS

CONNECTING THE WATER LINE

1. Turn off the main water supply.
2. Turn on the nearest faucet and allow it to run long enough to clear line of water.
3. Find a 1/2" (12.70 mm) to 1-1/4" (3.18 cm) vertical cold water pipe near the ice maker.

NOTE: A horizontal pipe will work, but drill on the top side of the pipe, not the bottom. This will keep water away from the drill motor, and also keeps normal sediment from collecting in the valve.

4. Using a grounded drill, drill a 1/4" (6.35 mm) hole in the cold water pipe you have selected.
5. Fasten a shutoff valve to the cold water pipe with a pipe clamp. Make sure that the outlet end is firmly in the 1/4" (6.35 mm) drilled hole, and that the washer is under the pipe clamp.

IMPORTANT: Do not use a piercing-type, or a 3/16" (4.76 mm) saddle-type valve. These can reduce water flow and easily become clogged.

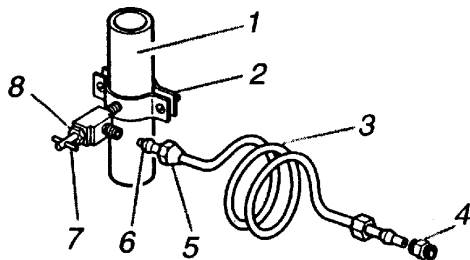

- | | |
|-------------------------|-----------------------|
| 1. Cold Water Pipe | 5. Compression Nut |
| 2. Pipe Clamp | 6. Compression Sleeve |
| 3. Copper Tubing | 7. Shutoff Valve |
| 4. Coupling (purchased) | 8. Packing Nut |

6. Tighten the packing nut.
7. Tighten the pipe clamp screws carefully and evenly so that the washer makes a watertight seal. Do not overtighten the pipe clamp. If the water line is soft copper tubing, you could crush it.

8. Use 1/4" (6.35 mm) O.D. copper tubing for the cold water supply and:
 - a) Measure from the connection at the back of the ice maker to the cold water pipe.
 - b) Add an extra 36" (91.4 cm) to ensure that you have the proper length. Make sure both ends of the copper tubing are cut square.
 - c) Slip a compression sleeve and compression nut over the ends of the copper tubing.
 - d) Insert the end of tubing into the water shutoff outlet as far as it will go, and screw the compression nut onto the outlet. Tighten the compression nut with an adjustable wrench, but do not overtighten it.
9. Place the free end of the copper tubing into a container or sink, and turn on the main water supply. Flush the tubing until water is clear, and then turn off the shutoff valve on the water pipe. NOTE: Always drain the water line before making the final connection to the inlet of the water valve to prevent a possible water valve malfunction.
10. Bend the copper tubing to meet the water line inlet, located on the back of the ice maker cabinet, as shown below.

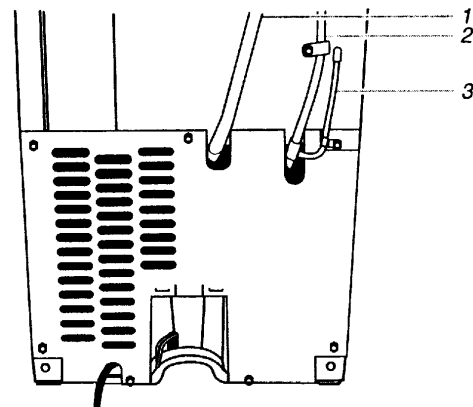

- | |
|--|
| 1. Drain Hose (Drain Pump models only) |
| 2. Vent Hose (Drain Pump models only) |
| 3. Water Supply Line |

- Thread the nut onto the coupling at the end of the copper tubing. Tighten the nut by hand. Then tighten it with a wrench two more turns. Do not overtighten.

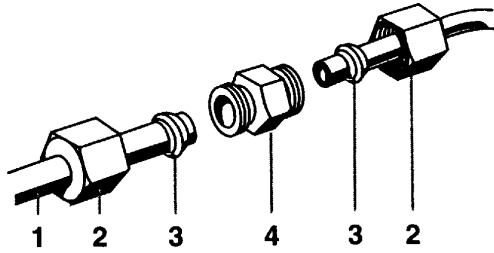

- Line to ice maker
- Nut (purchased)
- Ferrule (purchased)
- Coupling (purchased)

- Remove the four screws from the lower access panel and remove the panel from the front of the ice maker.

NOTE: To prevent rattling, keep the copper tubing from touching the cabinet side wall, or any other parts inside the cabinet.

FRONT VIEW

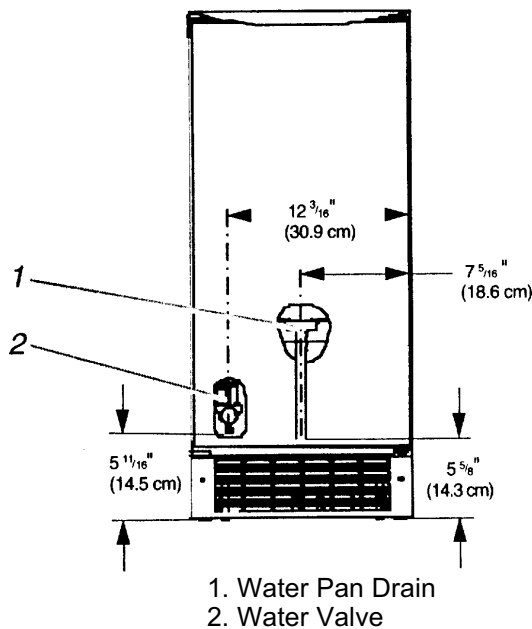

- Turn the shutoff valve ON.
- Check the water connections for leaks, and carefully tighten any that are leaking.
- Reinstall the lower access panel with its four screws.

CONNECTING THE DRAIN

Gravity Drain System

Connect the ice maker drain so that it is in accordance with all state and local codes and ordinances. If the ice maker is provided with a gravity drain system, use the following guidelines when installing the drain lines. This will prevent water from flowing back into the ice maker storage bin and onto the floor, causing water damage.

- Drain lines must have a minimum of 5/8" (15.88 mm) inside diameter.
- Drain lines must have a 1" drop per 48" (2.54 cm drop per 122 cm) of run, or 1/4" drop per 12" (6.35 mm per 30.48 cm) and not have any low points where water can settle.
- The floor drains must be large enough to accommodate drainage from all drains.
- The ideal installation has a standpipe with a 1-1/2" (3.81 cm) to 2" (5.08 cm) PVC drain reducer installed directly below the outlet of the drain tube, as shown. You must maintain a 1" (2.54 cm) air gap between the drain hose and the standpipe.
- It may be desirable to insulate the drain line up to the drain inlet.

SIDE VIEW

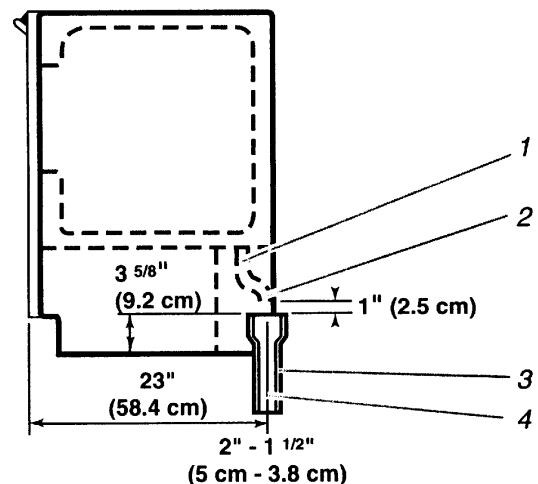

- Drain Hose
- 1" (2.54 cm) Air Gap
- PVC Drain Reducer
- Center of drain should be 23" (58.4 cm) from front of door, with or without the 3/4" (1.91 cm) panel on the door.

After ensuring that the drain system is adequate, use the following steps to properly place the ice maker:

1. Plug in the ice maker or reconnect power.
2. Recheck the ice maker and make sure that it is level.
3. Push the ice maker into position so that the drain tube is positioned over the PVC drain reducer.
4. If it is required by the local sanitation code, seal the cabinet to the floor with an approved caulking compound after all water and electrical connections have been made.

Drain Pump System (On Some Models)

Connect the drain pump hose (provided with the product) to the drain in accordance with all state and local codes and ordinances.

NOTE: If the drain hose becomes twisted and water cannot drain, the ice maker will not operate.

THEORY OF OPERATION

OPERATING SYSTEMS

There are three operating systems in the ice maker:

- Refrigeration System
- Water System
- Electrical System

REFRIGERATION SYSTEM

The refrigeration system in the ice maker is very similar to the system used in other refrigeration appliances. The refrigerant used in this unit is R134a.

There are two very important additions to the refrigeration system in the ice maker: the Hot Gas Valve, and the Condenser Accumulator Tube. The components operate as follows:

- Hot Gas Valve - Allows high pressure refrigerant gas to bypass the condenser and flow through the condenser accumulator tube.
- Condenser Accumulator Tube - Hot gas pushes liquid refrigerant through the accumulator tube into the evaporator, helping to evenly heat the evaporator plate so that the ice slab releases quickly and evenly.

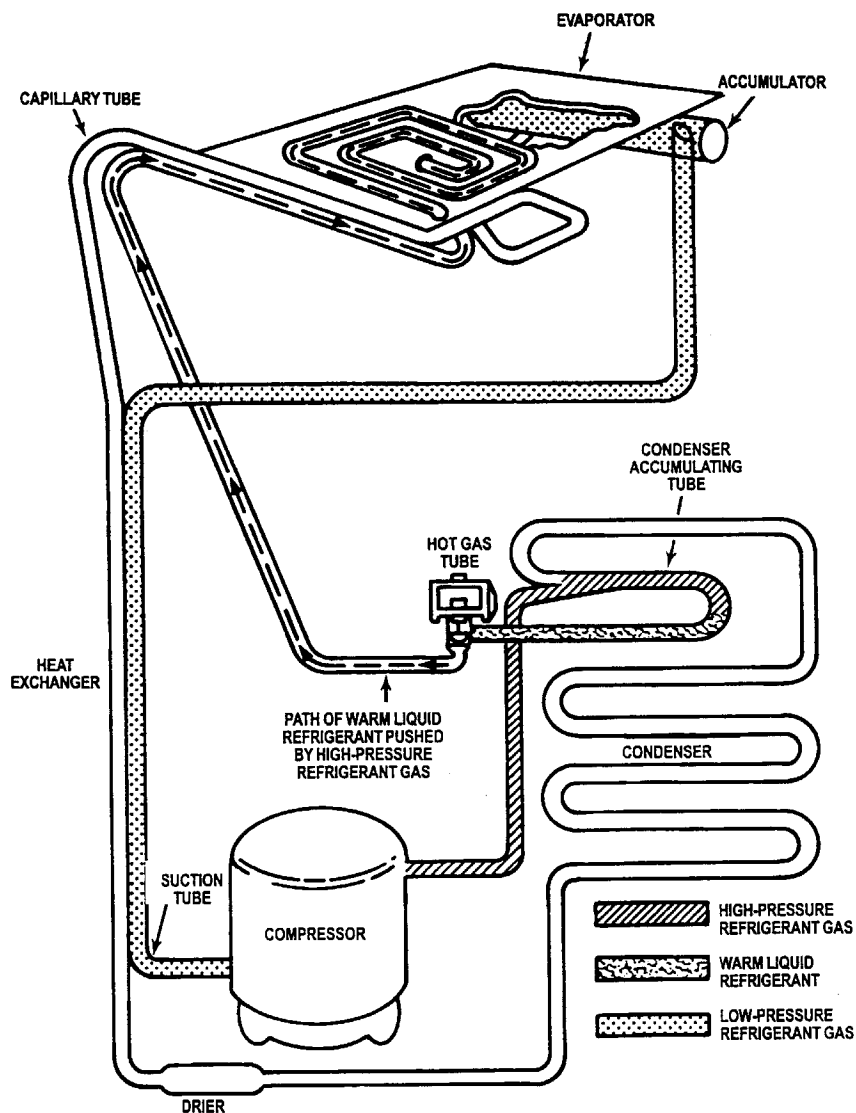

WATER SYSTEM

The water system provides:

- Fresh water for ice production
- Water recirculation as ice is produced

The water system also flushes away minerals and contaminants, circulates cleaning solution during the clean cycle, and provides drainage.

The hardness of the water supplied to the ice maker will affect the quality of the ice that is produced. It may also affect the operation of the water system.

A water softener, or polyphosphate feeder, will not cure all of the problems associated with hard water, but they can be used to reduce scale buildup in the ice maker. NOTE: Some polyphosphate feeders will cause a slime buildup in the water system when the water supply has a low mineral content.

The ice maker's water system is shown below.

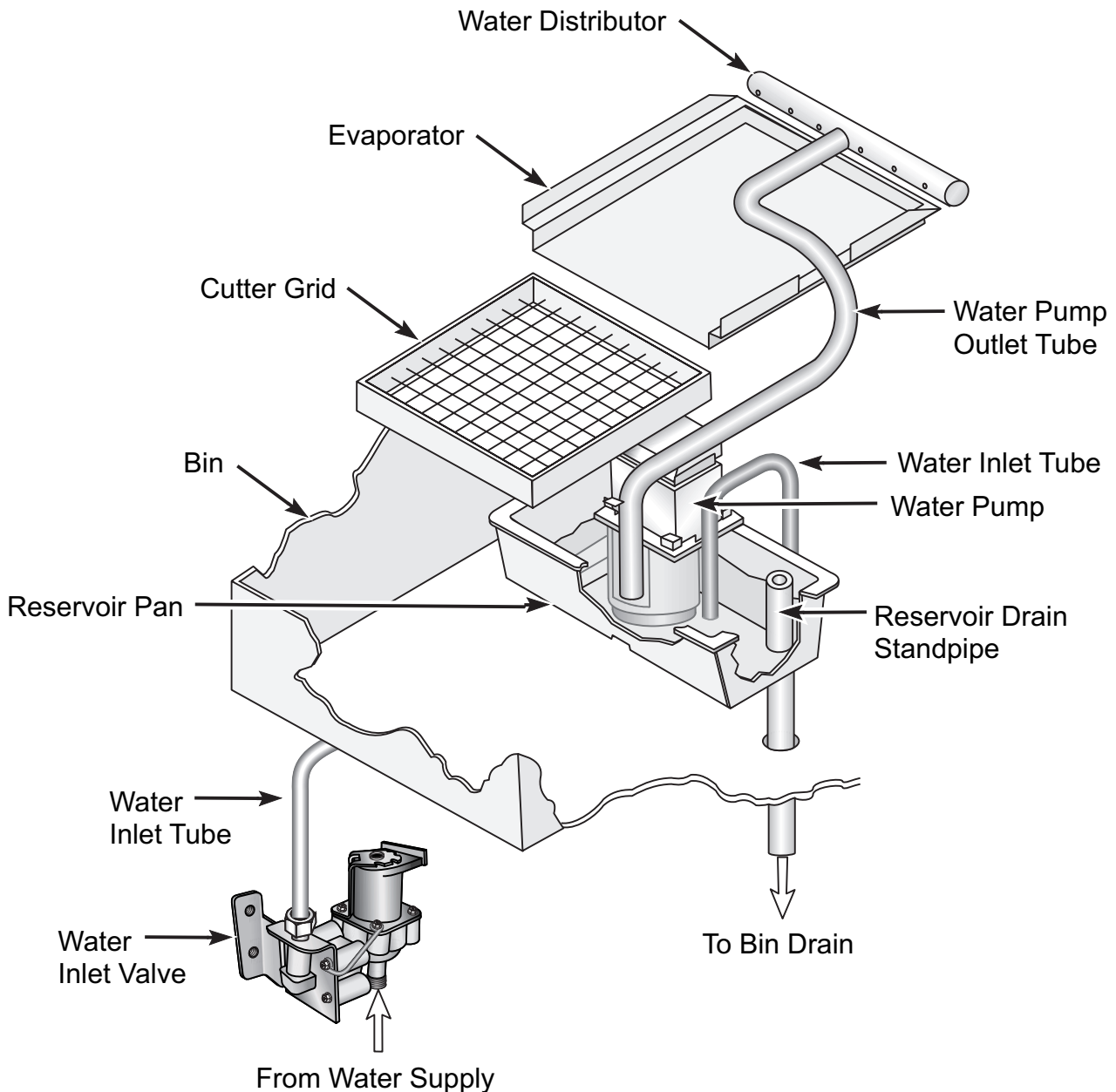

ELECTRICAL SYSTEM

The ice maker's electrical system provides power for the refrigeration and water systems, and controls the operational cycling.

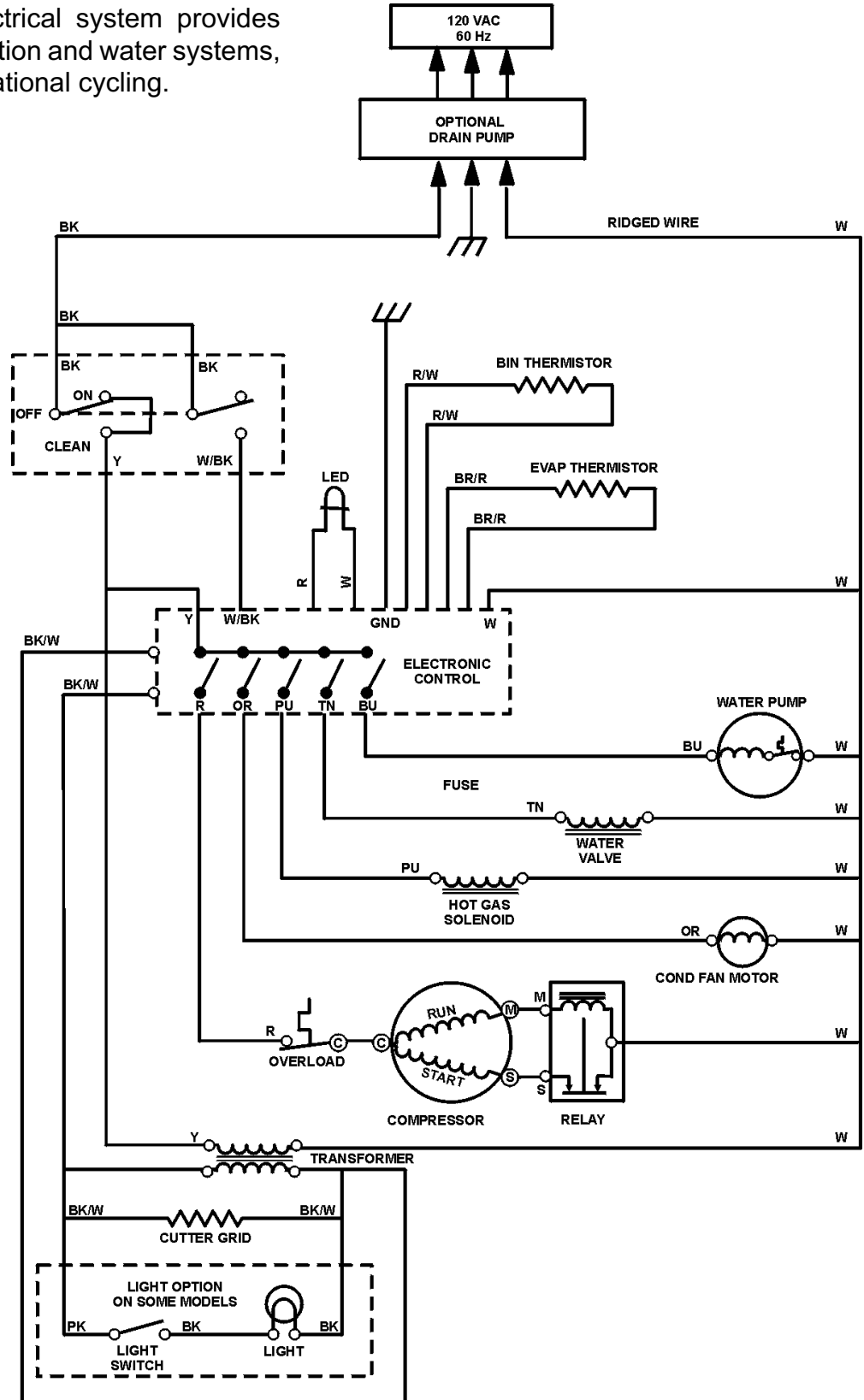

OPERATIONAL CYCLES

There are three main operational cycles for the ice maker (more detailed operation is found in the flow chart on page 6-5):

- Ice Making
- Harvest
- Diagnostics/Clean

ICE MAKING CYCLE

In addition, there are two possible “Off” cycles for the ice maker. They occur when:

1. The bin is full of ice and the service control switch is turned “ON” (Idle mode).
2. The service control switch is turned “OFF” while power is still supplied to the unit.

Electrical System

Power is supplied through the service control switches to the primary side of the voltage step-down transformer, (120 VAC reduced to 8.7 VAC for the cutter grid and the bin light), and the electronic control board. The electronic control board in turn supplies 120 VAC to the water recirculating pump, water inlet valve, hot gas solenoid, condenser fan motor, and compressor. An evaporator thermistor supplies temperature information to the electronic control.

Refrigeration System

The hot gas refrigerant, under high pressure, is forced through the condenser, where it changes into a liquid, and flows through the drier and capillary tube into the evaporator. Under low pressure in the evaporator, the liquid refrigerant absorbs heat from the water flowing over the evaporator. The refrigerant evaporates into a gas, and passes into the accumulator. As a low pressure gas, the refrigerant flows back through the suction line of the heat exchanger, to the compressor.

During the Ice Making cycle, some of the hot gas that is in the condenser accumulating tube, condenses to a liquid, and remains in the accumulating tube.

During the later stages of the Ice Making cycle, as the ice slab forms on the evaporator freezing plate, some of the refrigerant passing through the evaporator will not evaporate into a gas, but will remain a liquid. This liquid refrigerant will settle in the accumulator, while the refrigerant vapor is sucked off through the suction tube at the top of the accumulator. This accumulated liquid refrigerant will eventually be evaporated by the warmed refrigerant gas passing through the accumulator during the Harvest cycle, and during the beginning of the next Ice Making cycle.

NOTE: It is very important that the accumulator is not tilted out of a horizontal position. If moved, it could cause compressor failure.

Water System

The water recirculating pump moves the water from the reservoir pan up to the distributor, where it flows out over the evaporator freezing plate.

Water that does not freeze on the evaporator plate runs off the front edge, and falls back into the reservoir, where it is recirculated back to the water distributor.

As the ice slab forms, the minerals in the water are on the surface of the ice. The water flowing over the top of the ice slab washes these minerals back into the water reservoir pan. The water continues to recirculate until the ice slab reaches the set thickness. Thickness is determined by the placement of the P4 jumper, located on the control board.

Control board #6100499 with Code Date MGR/0245 (45th week, 2002), or higher, will allow ice thickness adjustments (see “Adjusting The Ice Thickness” on page 8-3).

HARVEST CYCLE

Electrical System

When the set temperature of the evaporator thermistor is reached, it signals the electronic control to terminate power to the condenser fan, and the water recirculating pump. Power is then supplied to the hot gas valve and water fill valve solenoids.

If the evaporator thermistor is unplugged, the control defaults to the maximum freeze and harvest times.

Refrigeration System

The hot gas valve opens, allowing high pressure refrigerant gas to bypass the condenser, and flow through the condenser accumulating tube. The hot gas pushes the liquid refrigerant that has accumulated in the accumulator tube up into the evaporator. The hot liquid refrigerant evenly heats the evaporator plate so that the ice slab releases quickly and evenly.

The ice slab, when released, slides off of the evaporator plate onto the cutter grid.

Water System

The water valve opens, allowing water to flow into the water reservoir pan. As the reservoir fills, the mineral-laden water from the previous Ice Making cycle, is flushed out the overflow tube.

As a result of the hot gas flow and the ice sliding off the evaporator plate, the evaporator temperature begins to rise. When the evaporator thermistor reaches the set temperature (6.5°F), the unit switches to the Ice Making cycle. This cycling between Ice Making and Harvest, continues until the ice bin is full.

The electronic control board controls the various components and systems in the ice maker for each of the Ice Making and Harvest cycles.

When the ice maker's service control switch is in the "On" position, and the bin is not full of ice, the evaporator thermistor determines whether the unit will be in the Ice Making, or the Harvest cycle.

If the thermistor is unplugged from the control board, the unit will cycle using maximum freeze and harvest times.

DIAGNOSTICS / CLEAN CYCLE

Electrical System

Power is supplied to the electrical components through the service control switch.

The electronic control board controls the various components and systems during the Diagnostics/Clean cycle. During the first 25 seconds of the cycle, each component will operate for 5 seconds.

For the order of the components cycled, see the flow chart on page 6-5.

Water System

When the service control switch is in the "Clean" position, the water recirculating pump circulates the cleaning solution that has been added to the reservoir, up to the water distributor, across the evaporator, and back into the reservoir, where it is recirculated.

NEW ICE MAKER CONTROL BOARD (#6100499)

NOTE: Due to a quality improvement, the new control board will replace the older design (#2185947).

If you are replacing control board #2185947, please read the improvements listed below. If you are replacing control board #6100499, you may disregard the following information.

There are no differences in mounting or wiring the new control board. Improvements were made to support low voltage applications.

Additional improvements include the following:

- A 15-minute minimum, and 25-minute maximum, ice making cycle time limit. This eliminates the production of ice slabs that are too thin or too thick. Control boards with Code Date MGR/0245, (45th week, 2002), or higher, will allow ice thickness adjustments by moving the jumper at P4 (see “Adjusting The Ice Thickness” on page 8-3).
- During a harvest, the water valve “on time” is now limited to 1 minute to reduce water usage. This also eliminates the condition of the water valve being energized for an unlimited amount of time if the evaporator thermistor is not located correctly, or if the reversing valve has failed or is unplugged. If the evaporator thermistor is unplugged, a 25-minute default freeze, and 4-minute harvest interval will occur.

If the unit stays in harvest mode for more than 16 minutes, the unit will go into a failure mode, shutting the unit down, and flashing the LED light. To get out of failure mode, shut the unit off, and then back on again. This will reset the control board. If the failure was not corrected, the unit will return to failure mode when the unit reaches it's 16-minute cycle again. If this occurs, find the cause of the failure, and repair it, then unplug the unit to reset the board.

- The diagnostic mode sequence was changed, moving the bin and evaporator thermistor checks to the beginning of the sequence. The old boards had these checks at the end of the sequence.
- Whenever the unit has reached a failure mode, the LED will flash, and the unit will shut down. If the failure was caused during a harvest cycle which lasted more than 16 minutes, the LED will remain flashing on & off in half-second increments. If the failure is caused by a faulty bin thermistor, (not detected), the LED will remain flashing on & off in 1-second increments. These are the only two failures that cause the unit to reach a shut-down failure mode.
- During the Clean cycle, the control board performs the diagnostics first. If the bin thermistor is not detected, the LED will flash two times. This is followed by a 3-second delay. If the evaporator thermistor is not detected, the LED will flash on five times. This will be followed by a 3-second delay. The LED will then come back on, and remain on for the remainder of the Clean cycle, and until the unit is turned back on.

The following check can be done on the board & thermistors:

- Unplug either thermistor electrical connection.
- Press the Clean switch. The LED should flash as described above, depending upon which thermistor is unplugged, or if both are unplugged.

For step-by-step operation, see the flow chart on page 6-5.

MODELS WITH INTERNAL DRAIN PUMPS

The power cord on the internal drain pump is connected to a 120 VAC wall outlet. The ice maker is then connected to the 120 VAC outlet on the drain pump. If the drain pump fails, or if the drain becomes blocked, power is shut off to the 120 VAC outlet on the drain pump.

When the unit is first plugged in, the drain pump will run for 20 seconds. The power can be disconnected and reconnected to verify that the pump is operating properly.

Water from the ice maker reservoir, or melting ice from the bin, drains down the bin drain tube

into the pump inlet, and then into the drain pump chamber. As the water level rises, it bridges the “full” contacts, and the pump starts to run. The pump discharges the water through the outlet and the check valve. When the “full” connection is removed, the pump runs for an additional 12 seconds to empty the tank.

If the water level in the drain pump continues to rise, due to a slow or blocked drain, or a blocked vent hose, and touches the “overflow” contact, power will be turned off to the drain pump’s 120 VAC outlet, causing the ice maker to turn off.

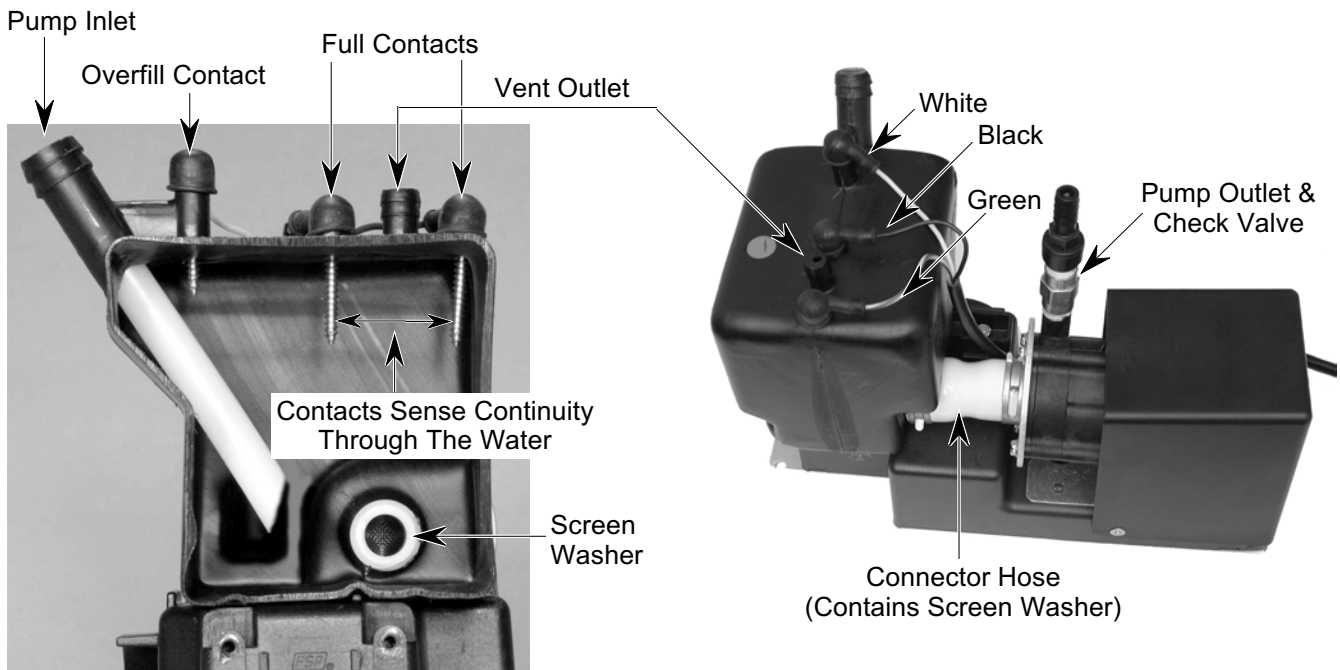

— NOTES —

COMPONENT ACCESS

This section instructs you on how to service each component inside the KitchenAid Automatic Ice Maker. The components and their locations are shown below.

COMPONENT LOCATIONS

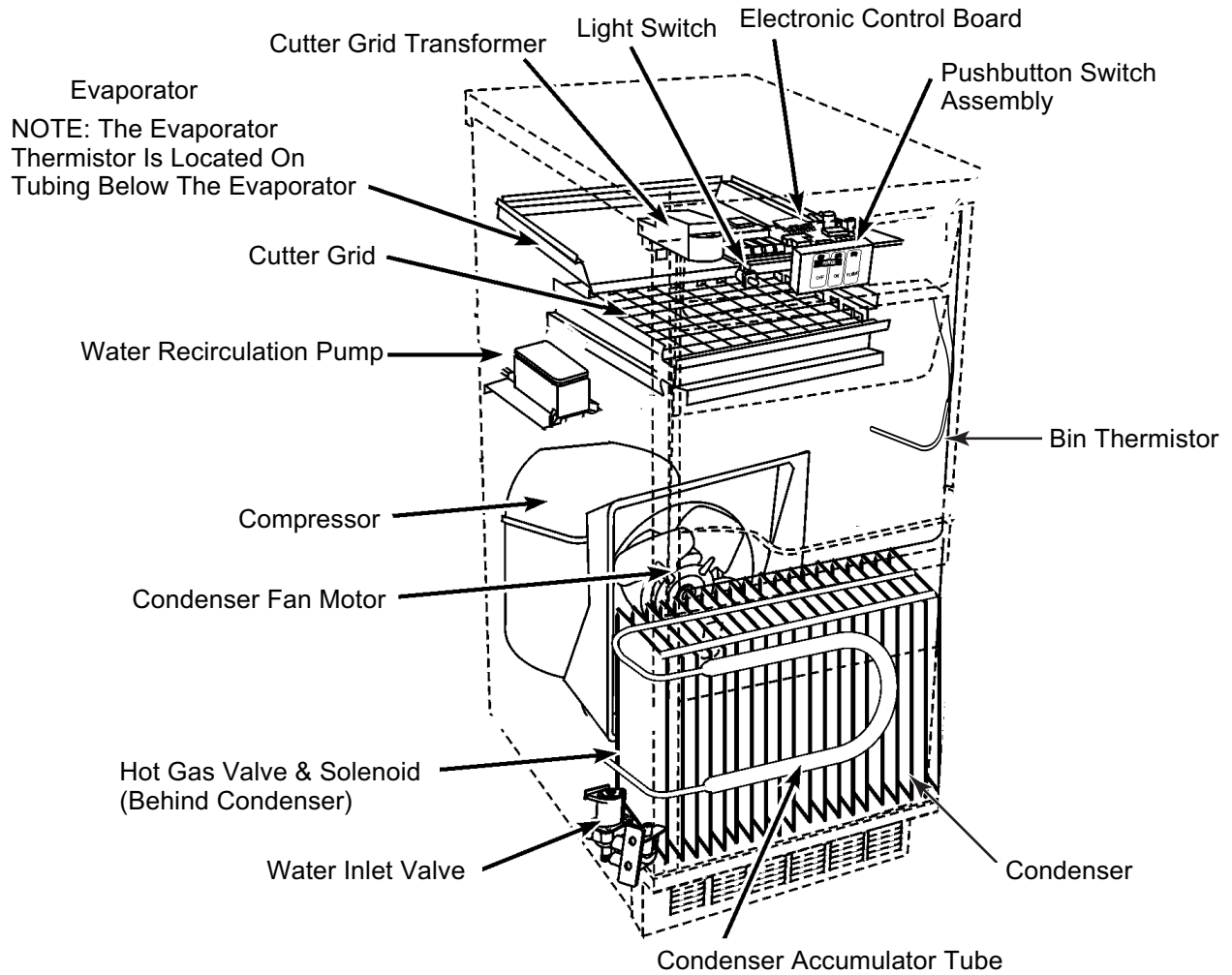

REMOVING THE BIN THERMISTOR, CUTTER GRID, EVAPORATOR THERMISTOR, & WATER DISTRIBUTOR

⚠️ WARNING



Electrical Shock Hazard

Disconnect power before servicing.

Replace all parts and panels before operating.

Failure to do so can result in death or electrical shock.

1. Unplug ice maker or disconnect power.
2. Open the ice maker door.
3. Cover or remove the ice from the storage bin.
4. Place a cloth in the drain hole to prevent hardware from falling inside.
5. Remove the two hex-head screws from the cutter grid cover and remove the cover.

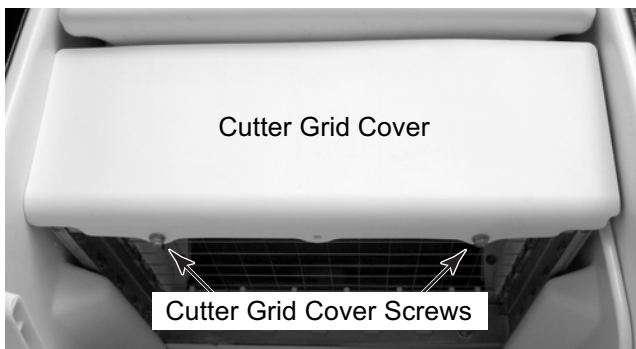

Cutter Grid Cover



6. To remove the bin thermistor:
 - a) Disconnect the bin thermistor connector from the bottom of the control housing.
 - b) Pull the bin thermistor out of the retaining clamp and remove it.

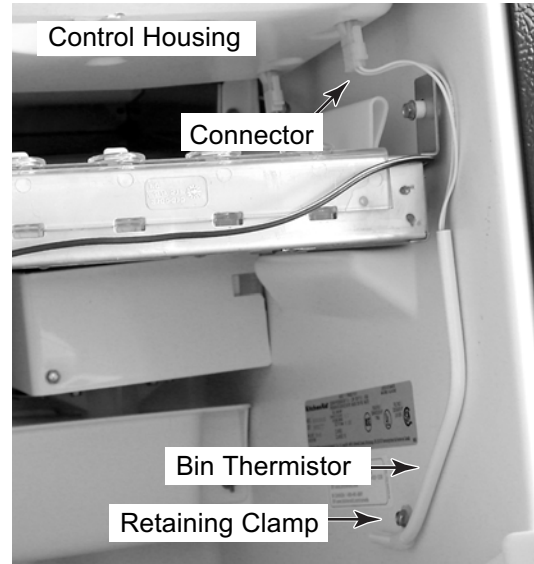

7. To remove the cutter grid:
 - a) Disconnect the cutter grid and bin thermistor connectors from the bottom of the control housing.
 - b) Remove the two hex-head screws from both sides of the cutter grid.

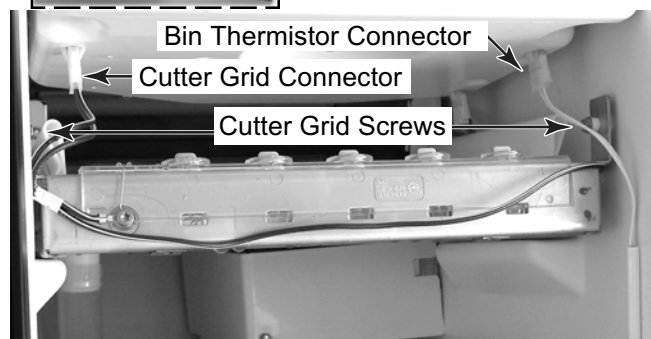
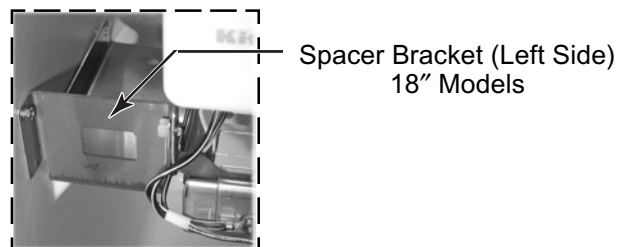

- c) Slide the cutter grid forward and out of the unit and place it on a work surface. Be careful not to scratch the ice maker liner.
- d) Remove the spacer from the right cutter grid bracket tab.

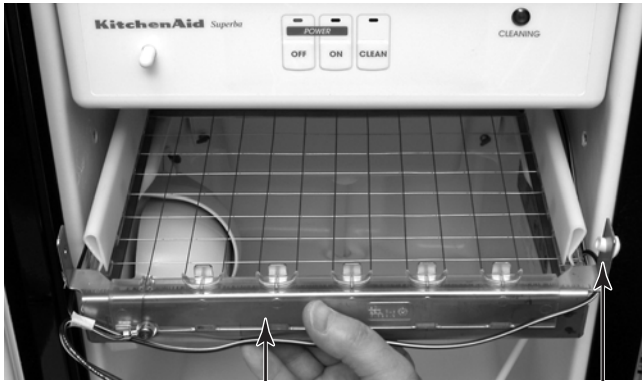

Slide Out Cutter Grid Spacer

- e) Lift the two ice guides from the cutter grid tabs. Note the orientation of the guides with the straight side facing in. There should be a slight outward tilt after the guides are installed. Bend the metal tabs outward, if necessary.

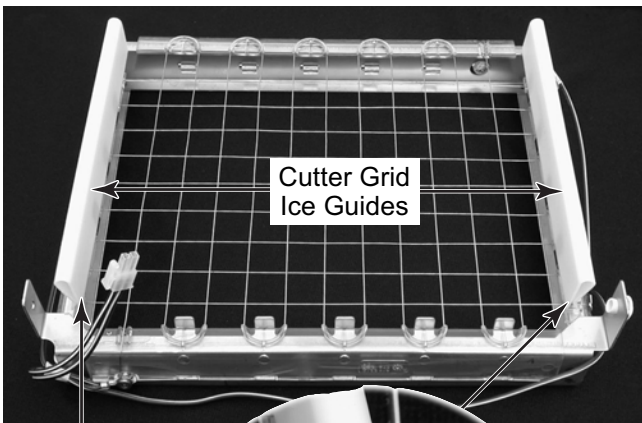

Position Ice Guide
With Straight Side
As Shown

- 8. **To remove the evaporator thermistor:**
 - a) Remove the cutter grid from the unit (see step 7 on page 4-2 for the procedure).
 - b) Disconnect the evaporator thermistor connector from the bottom of the control housing.
 - c) Remove the two hex-head mounting screws from the water trough and pull the trough from the unit.

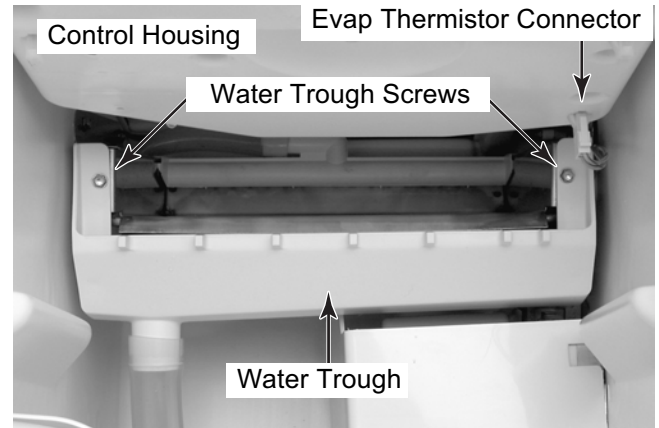

- d) Reach behind the accumulator, and unclip the evaporator thermistor from the evaporator tubing and remove it.

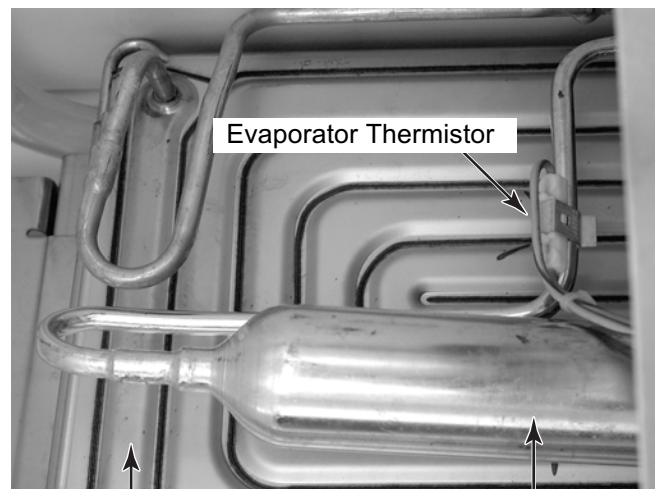

Bottom Of The Evaporator

Accumulator

Continued on the next page.

9. **To remove the water distributor:**

- a) Remove the cutter grid from the unit (see step 7 on page 4-2 for the procedure).
- b) Pull out on the left and right water distributor retainers, and remove the tabs from the slots in the evaporator. Pull the distributor forward and remove the water hose.

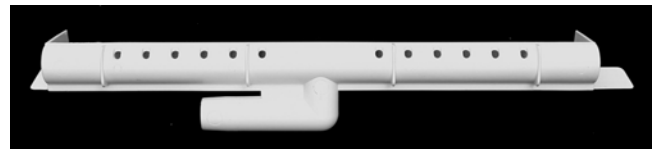
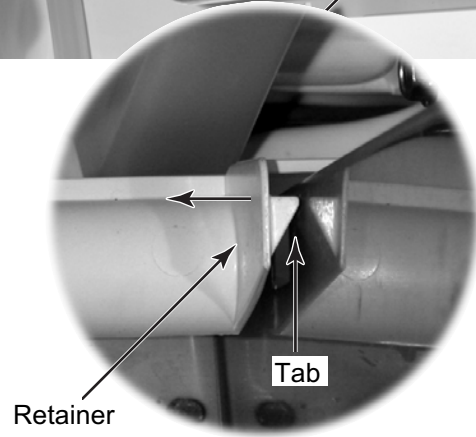
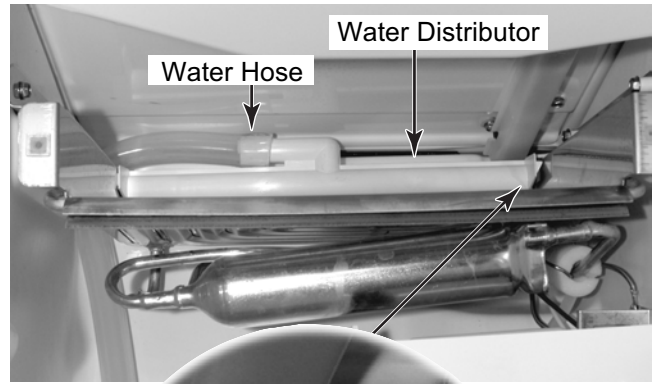

Water Distributor

REMOVING THE ELECTRONIC CONTROL HOUSING COMPONENTS

⚠️ WARNING



Electrical Shock Hazard
Disconnect power before servicing.
Replace all parts and panels before operating.
Failure to do so can result in death or electrical shock.

1. Unplug ice maker or disconnect power.
2. Open the ice maker door.
3. Cover or remove the ice from the storage bin.
4. Remove the cutter grid cover and the cutter grid (see page 4-2 for the procedures).
5. Disconnect the remaining two connectors (bin and evaporator thermistors) from the bottom of the control housing.
6. Remove the four hex-head screws from the control housing and lower the housing so that you can access the components.

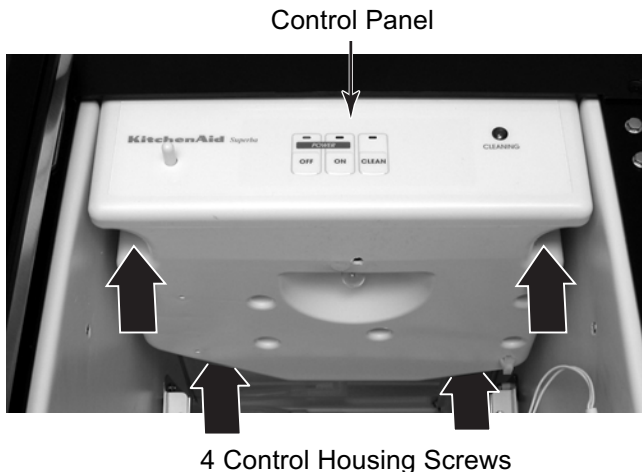

NOTE: The control housing components consist of:

- (1) Electronic control board
- (2) Cutter grid transformer
- (3) Light switch
- (4) Pushbutton switch assembly

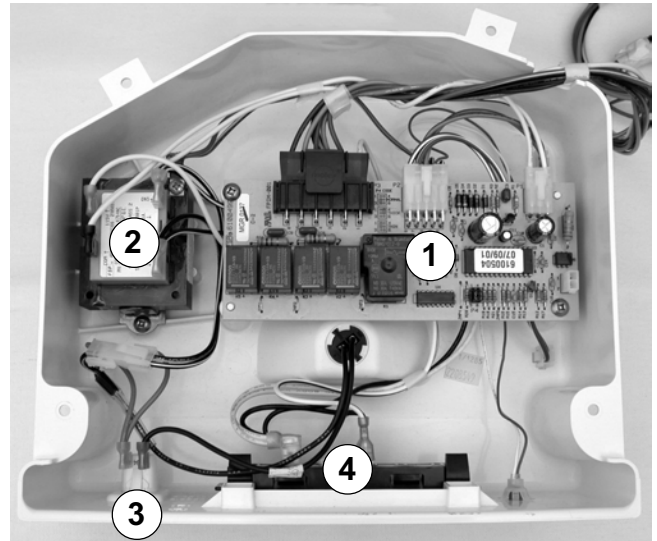

7. **To remove the electronic control board:**
 - a) Disconnect the three harness connectors from the board terminals.
 - b) Remove the two mounting screws.

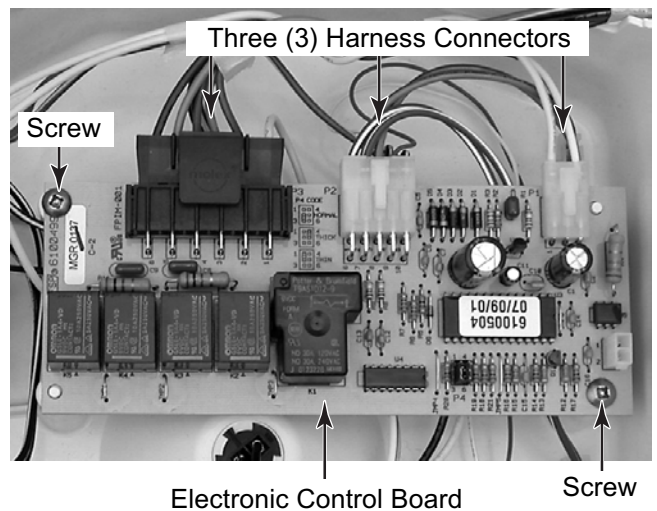

Continued on the next page.

8. **To remove the cutter grid transformer:**

- a) Disconnect the white & yellow wires from the primary terminals, and the black/white wires from the secondary terminals.
- b) Remove the two mounting screws from the transformer bracket.
- c) Disconnect the green ground wire from its terminal.

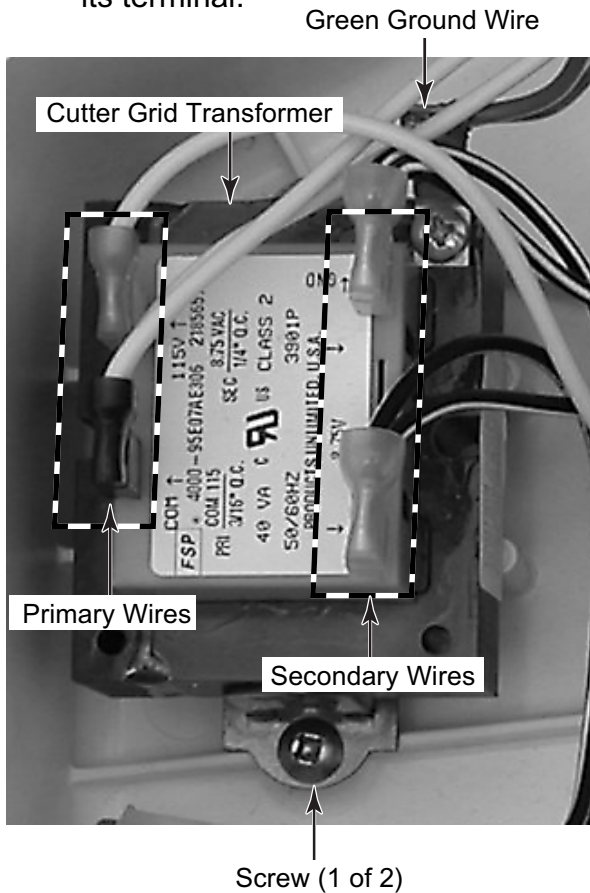

NOTE: If the pushbutton switch assembly or light switch is replaced, the replacement part and decorative overlay must be ordered using the model number of the ice maker. The service replacement switch is not supplied with a decorative overlay.

9. **To remove the light switch or pushbutton switch assembly:**

- a) Peel off the decorative overlay from the front of the control housing.



- b) Disconnect the wires from the switch terminals.
- c) Press the locking arms and push the switch assembly out of the housing.

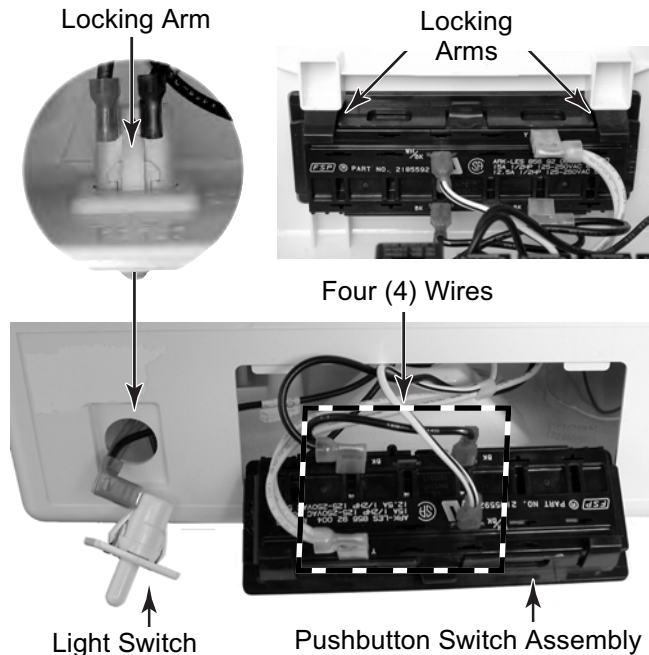

⚠️ WARNING

Electrical Shock Hazard
Connect green ground wire to ground terminal.
Failure to do so can result in death or electrical shock.

REMOVING THE WATER RECIRCULATION PUMP

!WARNING



Electrical Shock Hazard
Disconnect power before servicing.
Replace all parts and panels before operating.
Failure to do so can result in death or electrical shock.

1. Unplug ice maker or disconnect power.
2. Open the ice maker door.
3. Remove the ice from the storage bin.
4. Unscrew the drain cap from the reservoir, drain the water, and replace the cap tightly.
5. Place a cloth in the drain hole to prevent hardware from falling inside.
6. Remove the two thumbscrews from the reservoir and remove the reservoir from the unit.

Spacer Bracket (Left Side) 18" Models

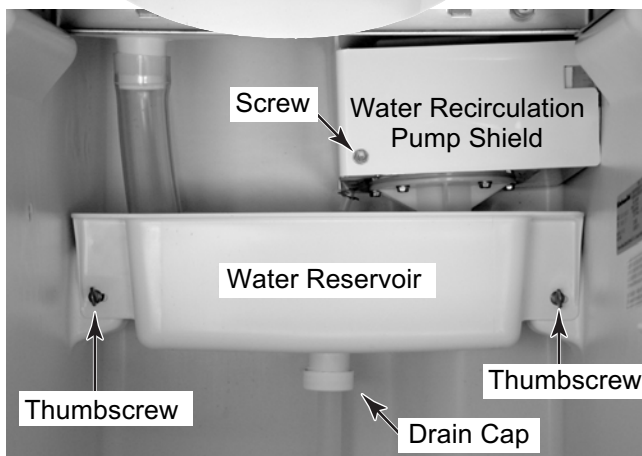

7. Remove the hex-head screw from the water recirculation pump shield and remove the shield (see the lower left photo).
8. Pull the water fill tube out of the slot in the water recirculation pump bracket.
9. Remove the three hex-head screws from the water recirculation pump bracket.
10. Disconnect the water recirculation pump 3-wire connector from the harness and remove the pump.
11. Disconnect the water tube from the pump.

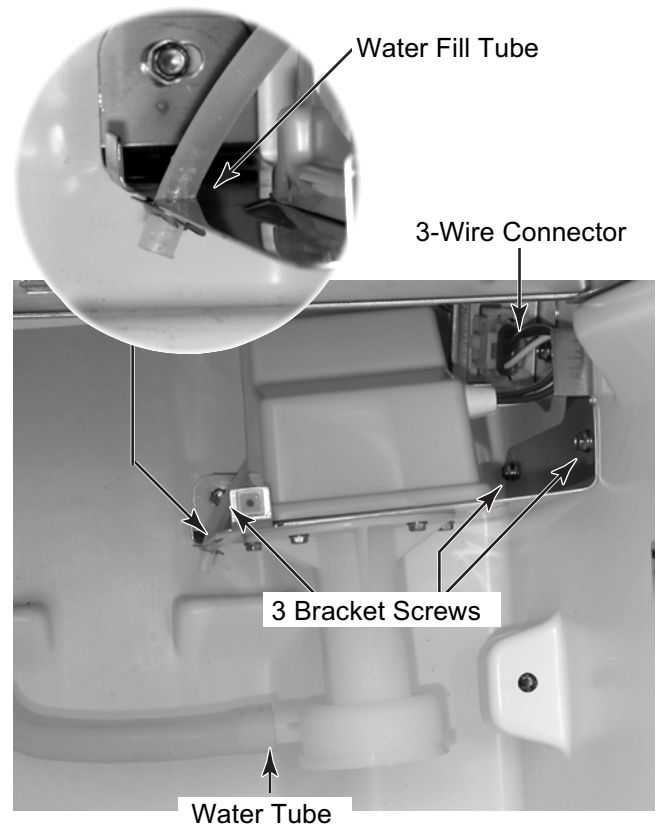

REMOVING THE CONDENSER FAN MOTOR

⚠️ WARNING



Electrical Shock Hazard

Disconnect power before servicing.

Replace all parts and panels before operating.

Failure to do so can result in death or electrical shock.

1. Unplug ice maker or disconnect power.
2. Open the ice maker door.
3. Remove the ice from the storage bin.
4. Disconnect the water and drain lines from the ice maker and remove the unit from its installation.
5. Remove the four hex-head screws from the front panel and remove the panel.



6. Remove the two 5/16" screws from the front of the cabinet.
7. Disconnect the water outlet tubing from the water valve.
8. Disconnect the electrical connectors from the water inlet valve and hot gas valve terminals.

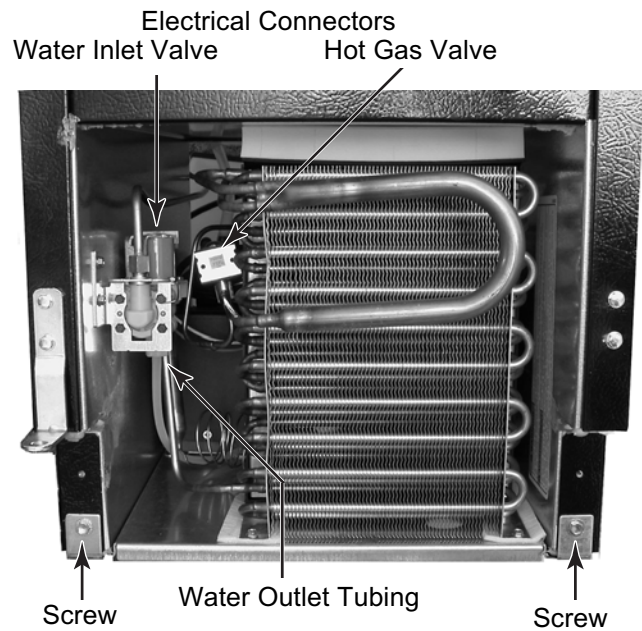

NOTE: If the unit you are servicing is equipped with an internal drain pump, perform steps 9 and 10. If the unit does not have an internal pump, skip those steps, and proceed to step 11 on the next page.

9. From the back of the unit, remove the four screws from the unit compartment cover and remove the cover.

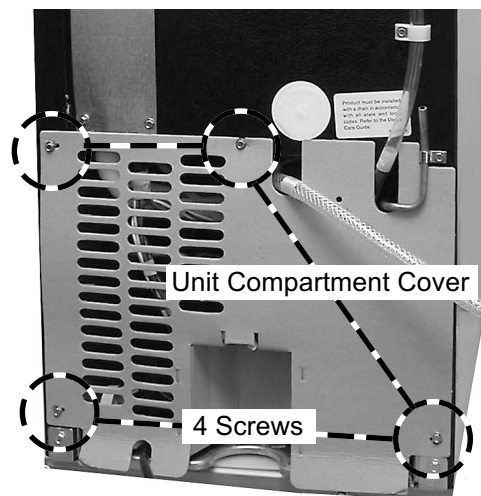

10. Disconnect the inlet tube and the vent tube from the internal drain pump.

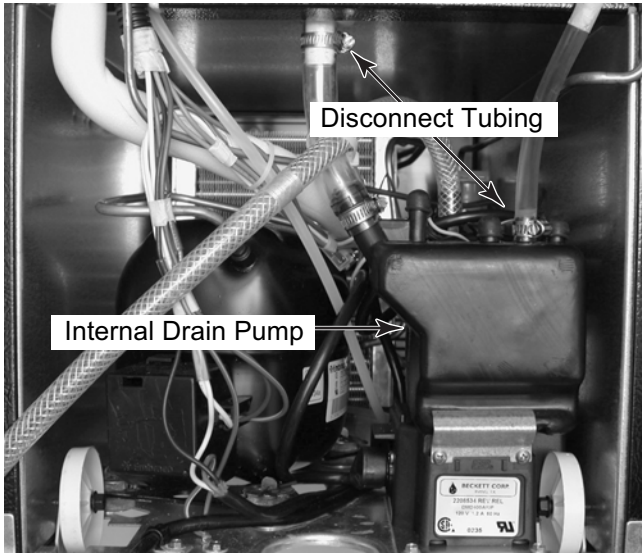

11. Tilt the front of the cabinet up until you can access the two side screws on the condenser fan motor shroud, and secure the cabinet so that it cannot tip forward or backward.

Tilt Cabinet Back



12. Disconnect the wire connector from the condenser fan motor.
13. Remove the four screws (two bottom and two side) from the condenser fan motor shroud. Slide the shroud assembly back towards the compressor, and then lift and remove the assembly from the unit.

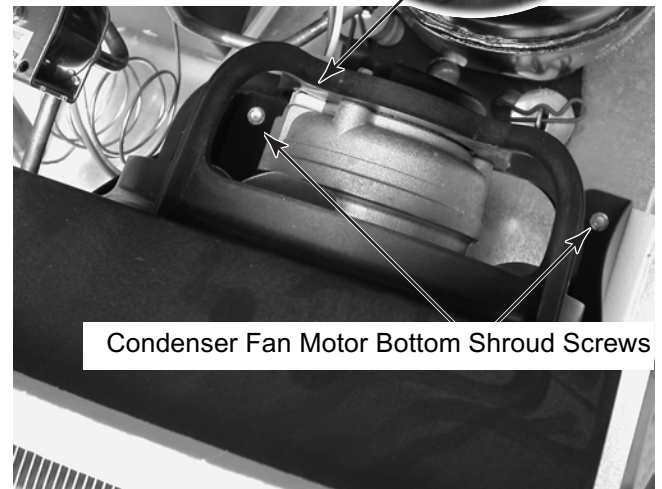
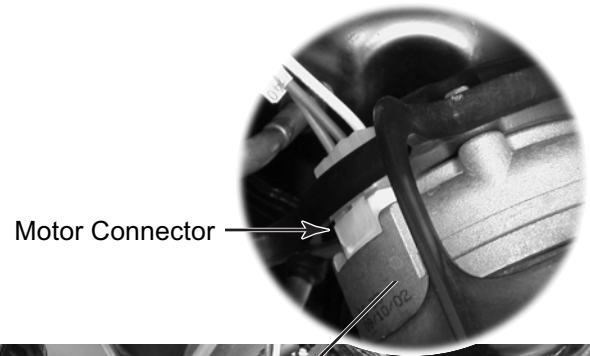

Condenser Fan Motor Left Side Shroud Screw



Continued on the next page.

14. Remove the nut from the condenser fan motor blade and remove the blade. NOTE: Make sure to reinstall the fan with the "NUT SIDE" marking facing the nut.



15. Remove the three hex-head screws from the condenser fan motor and remove it from the shroud.

Condenser Fan Motor Screw (1 of 3)



REMOVING THE EVAPORATOR

!WARNING



Electrical Shock Hazard

Disconnect power before servicing.

Replace all parts and panels before operating.

Failure to do so can result in death or electrical shock.

1. Unplug ice maker or disconnect power.
2. Open the ice maker door.
3. Remove the ice from the storage bin.
4. Remove the cutter grid and the evaporator thermistor from the unit (see pages 4-2 and 4-3 for the procedures).
5. Disconnect the bin thermistor connector from the bottom of the control housing (see page 4-2).
6. Remove the top door screw from the ice maker door, and pull the door off the bottom hinge.



7. Remove the two 5/16" hex-head screws from the top hinge and remove the hinge.



8. Remove the two front and two rear screws from the cabinet top.



9. Lift the cabinet top and position it forward on top of the unit.

Continued on the next page.

- 10. 18" Models Only:** Remove the six screws from the counterbalance plate and remove the plate from the rear of the unit.
- From the rear of the unit, remove the six hex-head screws from the channel cover and remove the cover.
- Remove the four screws from the unit compartment cover and remove the cover.

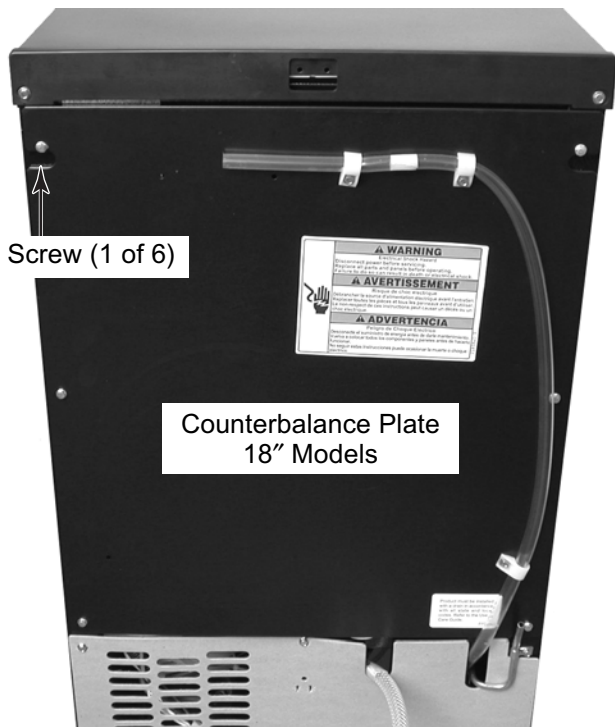

- Cut the tie wrap from around the tubing and wire harness inside the channel.

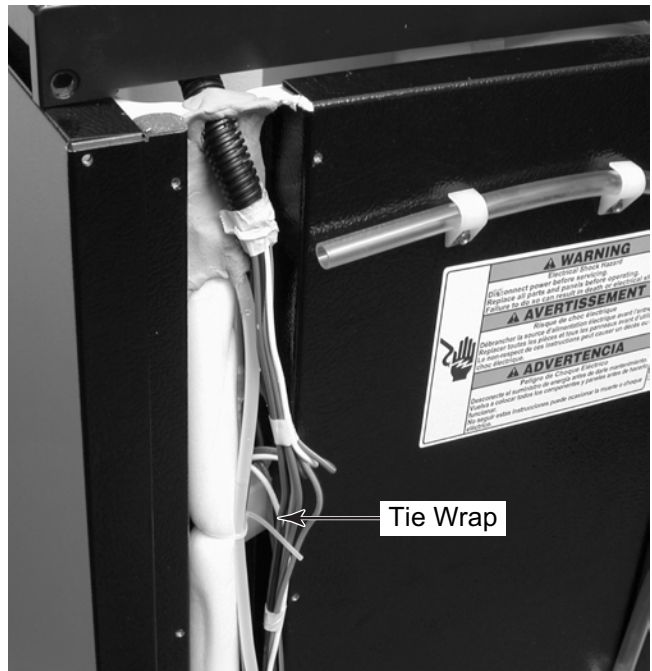

- Remove the two screws from the reservoir water trough and remove the trough.

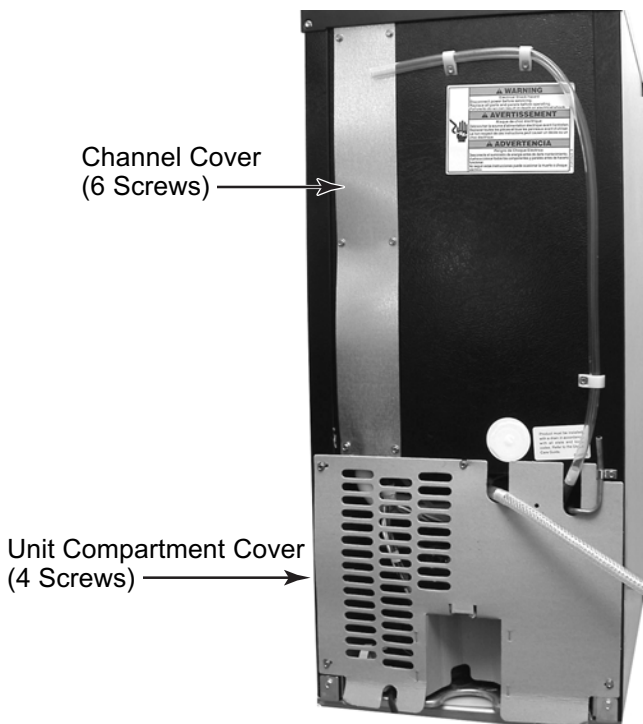
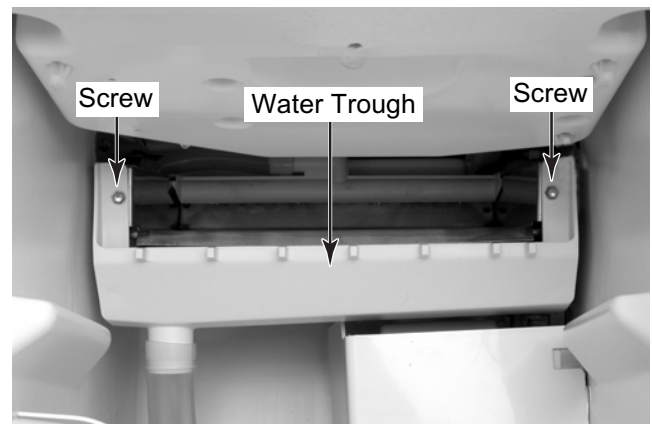

15. Remove the hex-head screw from the water recirculation pump shield and remove the shield.
16. Remove the water fill tube from the notch in the water recirculation pump bracket, and pull the free end of the water line up, out of the unit.

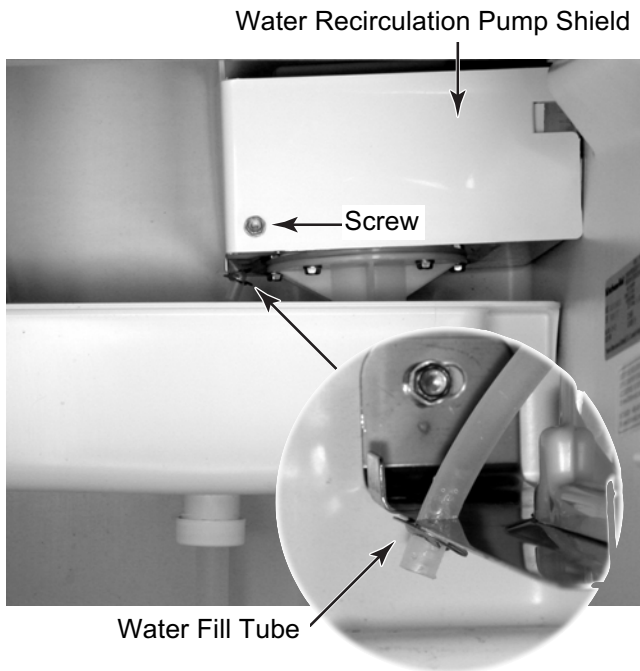

Refer to the photos at the top of the next column.

17. Pull out on the left and right water distributor retainers and remove the tabs from the slots in the evaporator, disconnect it from the hose, and remove it.
18. Remove the four screws from the evaporator, then carefully lift the evaporator just high enough to remove the two right spacers.

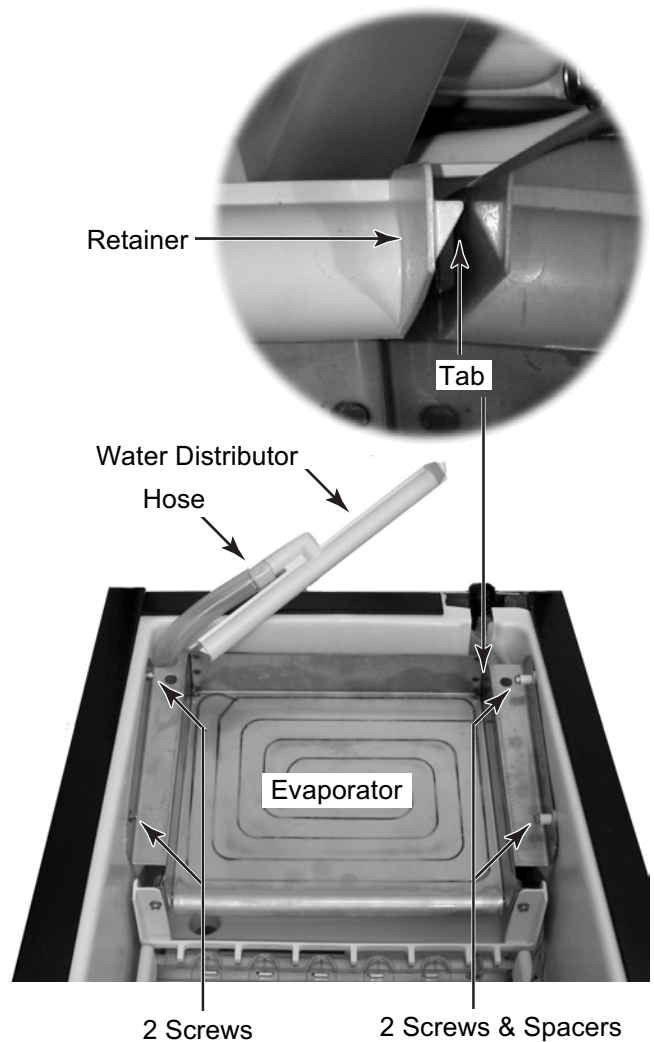

19. Remove the Permagum from the liner channel.

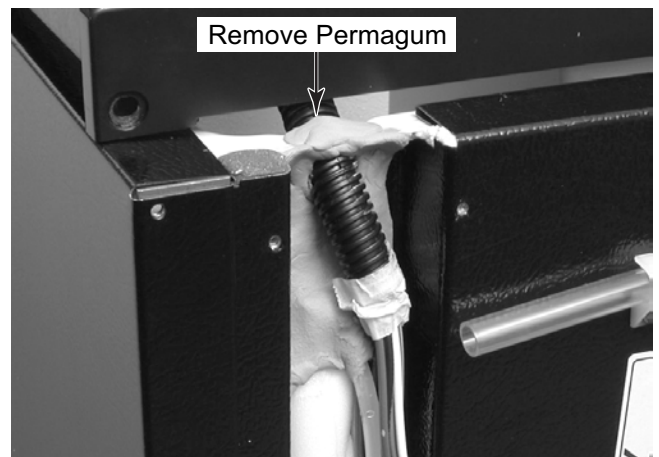

Continued on the next page.

20. Lift the cabinet top off the unit and stand it on the floor near the rear of the unit.
21. Lift the evaporator and its connecting tubing high enough from the unit to access the tubing underneath.

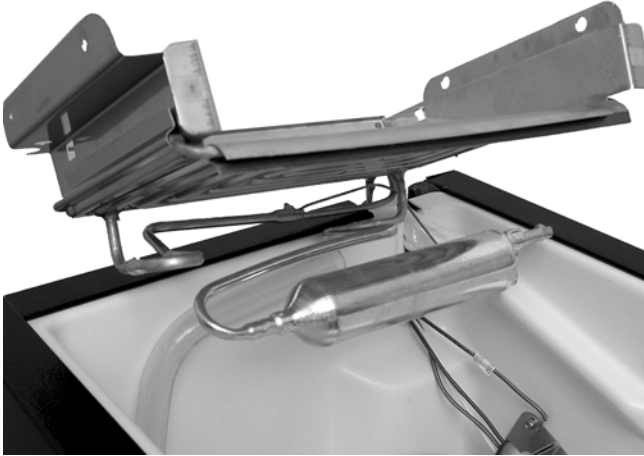

22. Access the sealed system and discharge the refrigerant into an approved recovery system.
23. Unbraid (and cut) the evaporator from the tubing at the following locations:
 - Suction line at the compressor.
 - Hot gas line at the hot gas valve.
 - Cut capillary tube at the filter/drier.

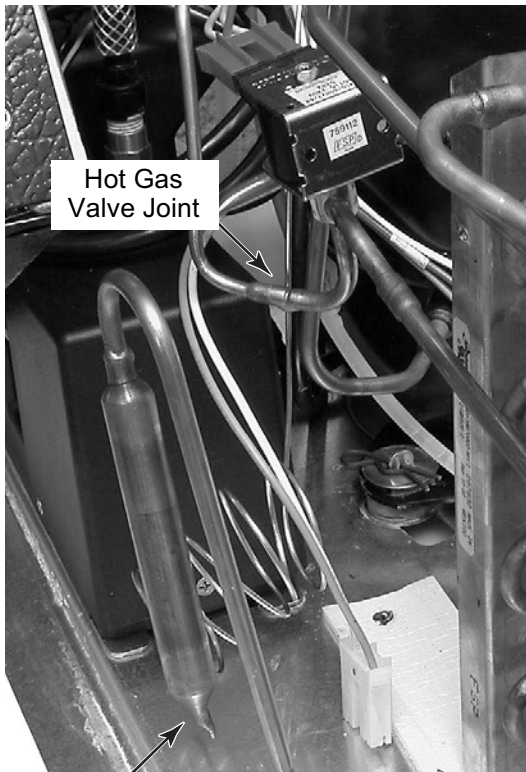

Filter/Drier Capillary Tube

REASSEMBLY NOTES:

- When installing the new evaporator, use a generous amount of thermal heat trap paste between the hot gas valve, and the evaporator tubing joint to protect the hot gas valve when brazing.
- Be sure to reinstall the Permagum in the liner channel of the cabinet around the wire sheath and tubing, so that there are no air leaks after the cabinet top is installed (see the photo in step 19 on page 4-13).



REMOVING THE WATER INLET VALVE

!WARNING



Electrical Shock Hazard
Disconnect power before servicing.
Replace all parts and panels before operating.
Failure to do so can result in death or electrical shock.

1. Unplug ice maker or disconnect power.
2. Open the ice maker door.
3. Disconnect the water and drain lines from the ice maker and remove the unit from its installation.
4. Remove the four hex-head screws from the front panel and remove the panel.

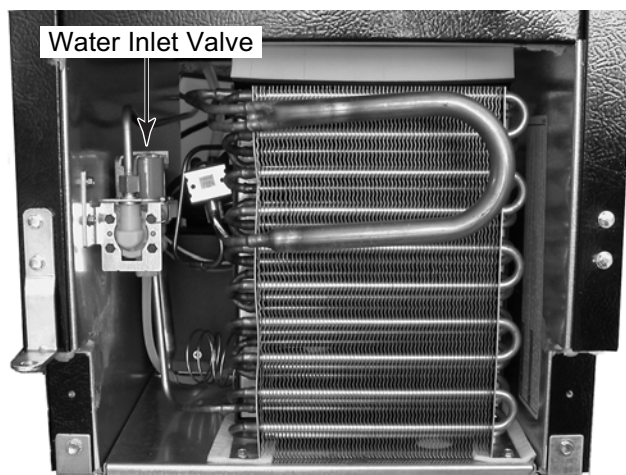

5. Disconnect the water inlet and outlet tubing from the water inlet valve.
6. Remove the two hex-head screws from the water inlet valve bracket.

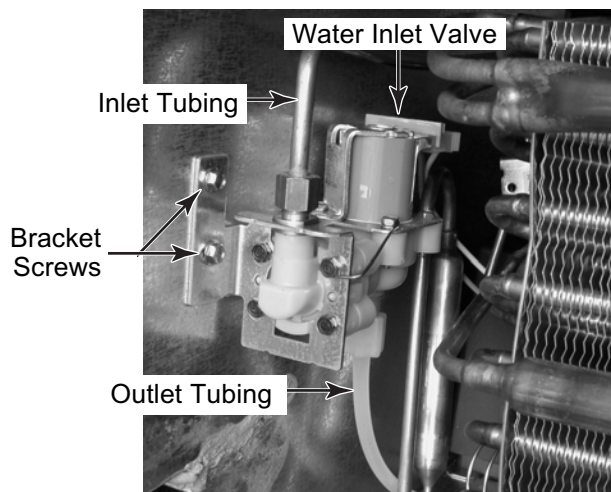

7. Disconnect the 2-wire connector from the water inlet valve terminals.

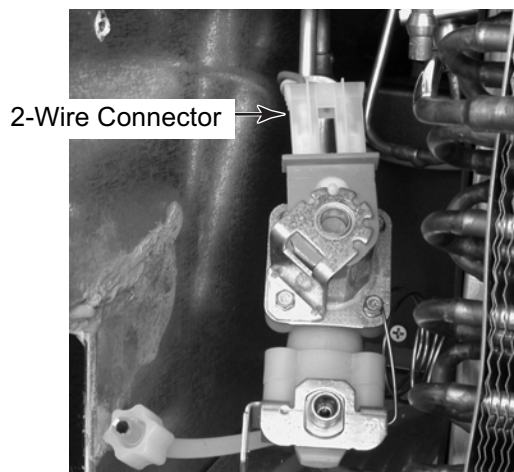

REMOVING THE HOT GAS VALVE & SOLENOID

⚠️ WARNING



Electrical Shock Hazard

Disconnect power before servicing.

Replace all parts and panels before operating.

Failure to do so can result in death or electrical shock.

1. Unplug ice maker or disconnect power.
2. Tip the front of the cabinet back and prop it up (see steps 2 through 11 on pages 4-8 and 4-9 for the procedure).

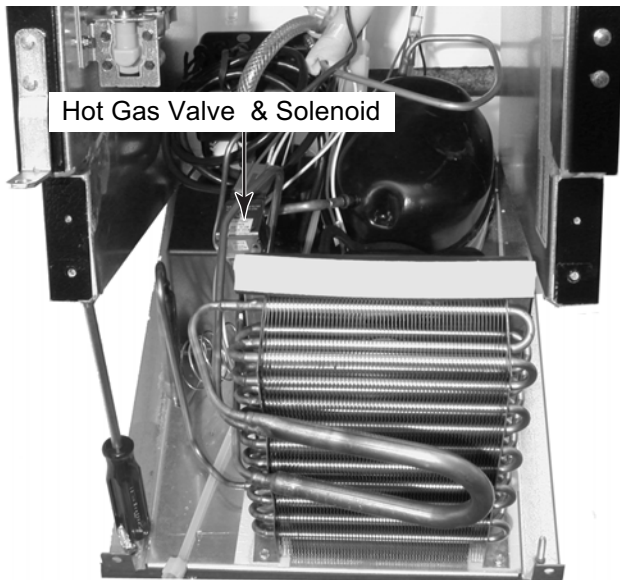

3. To remove the hot gas valve solenoid (see the photo at the top of the next column):
 - a) Disconnect the 2-wire connector from the solenoid terminals.
 - b) Remove the 7mm hex-head screw from the solenoid and lift the solenoid off the hot gas valve.

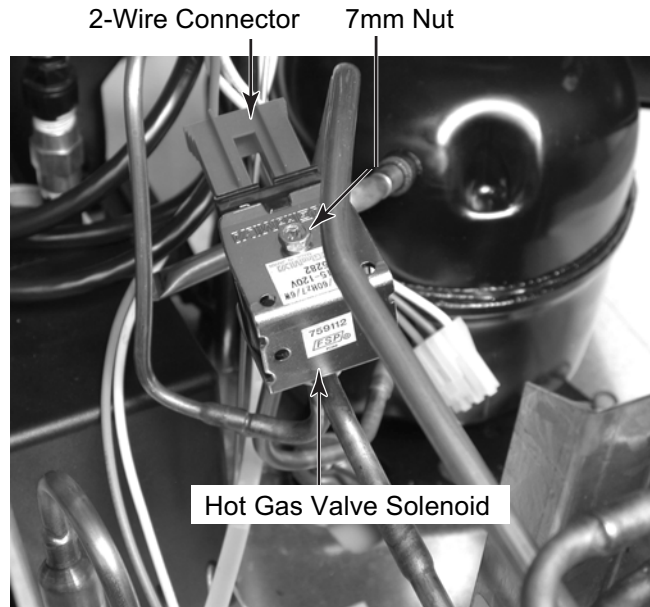

4. To remove the hot gas valve:
 - a) Remove the solenoid from the hot gas valve (see step 3 for the procedure).
 - b) Access the sealed system and discharge the refrigerant into an approved recovery system.
 - c) Unbrazed the hot gas valve from the tubing.

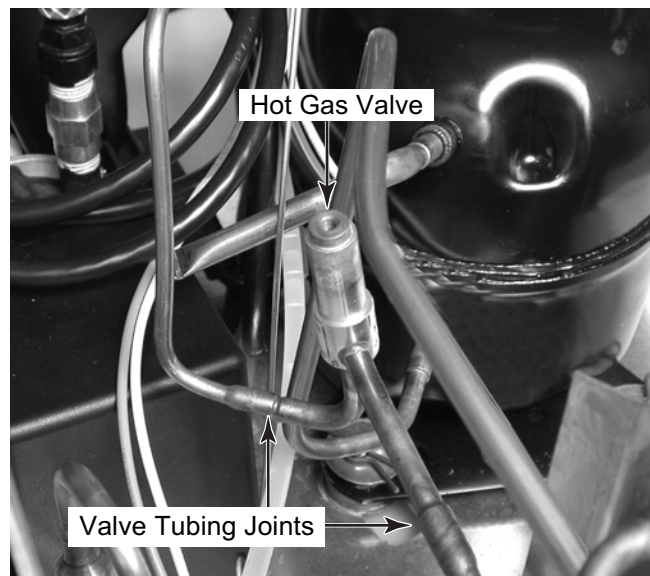

REASSEMBLY NOTE: When installing the new hot gas valve, use a generous amount of thermal heat trap paste between the valve and tubing joints to protect the valve when brazing.

REMOVING THE CONDENSER

!WARNING



Electrical Shock Hazard

Disconnect power before servicing.

Replace all parts and panels before operating.

Failure to do so can result in death or electrical shock.

1. Unplug ice maker or disconnect power.
2. Tip the front of the cabinet back and prop it up (see steps 2 through 11 on pages 4-8 and 4-9 for the procedure).

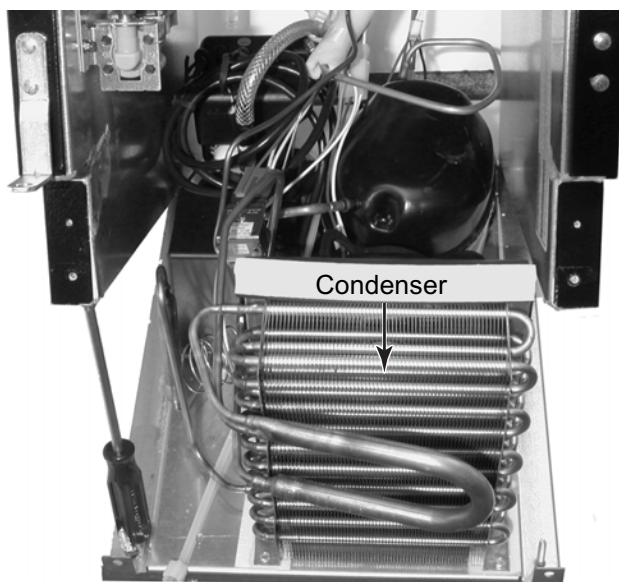

3. Remove the four condenser fan motor screws from the fan motor shroud and pull the motor assembly back away from the evaporator as far as possible, but do not remove it (see step 13 on page 4-9 for the procedure).
4. Remove the two mounting screws from the condenser bracket flanges.
5. Access the sealed system and discharge the refrigerant into an approved recovery system.
6. Unbraid the two condenser joints from the tubing.

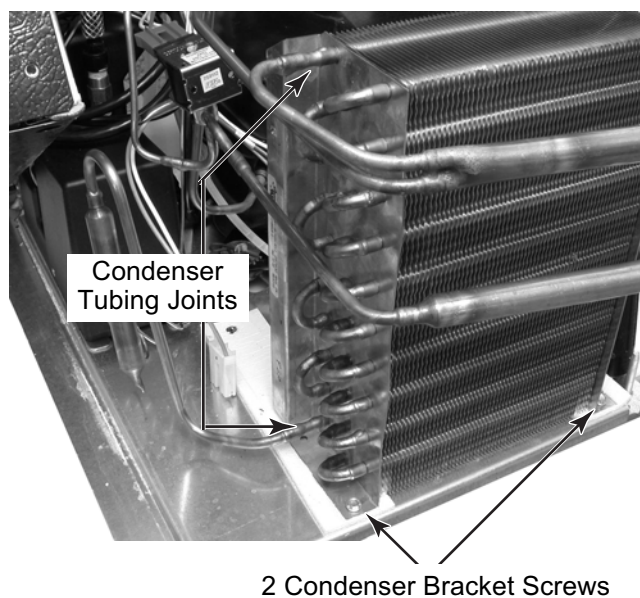

REMOVING THE COMPRESSOR

!WARNING



Electrical Shock Hazard

Disconnect power before servicing.

Replace all parts and panels before operating.

Failure to do so can result in death or electrical shock.

1. Unplug ice maker or disconnect power.
2. Open the ice maker door.
3. Remove the ice from the storage bin.
4. Disconnect the water and drain lines from the ice maker and remove the unit from its installation.
5. At the rear of the unit, remove the four screws from the unit compartment cover and remove the cover.

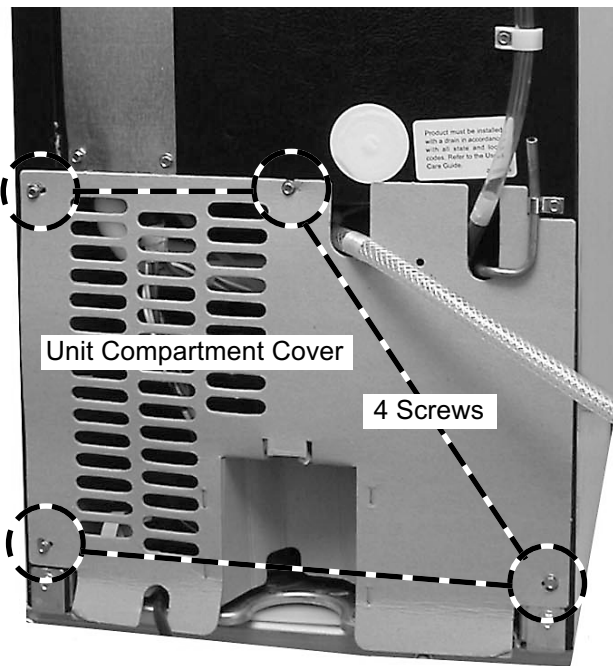

6. Remove the terminal cover using a standard screwdriver. Insert the screwdriver into the cover slot, and press down to unsnap and remove it.

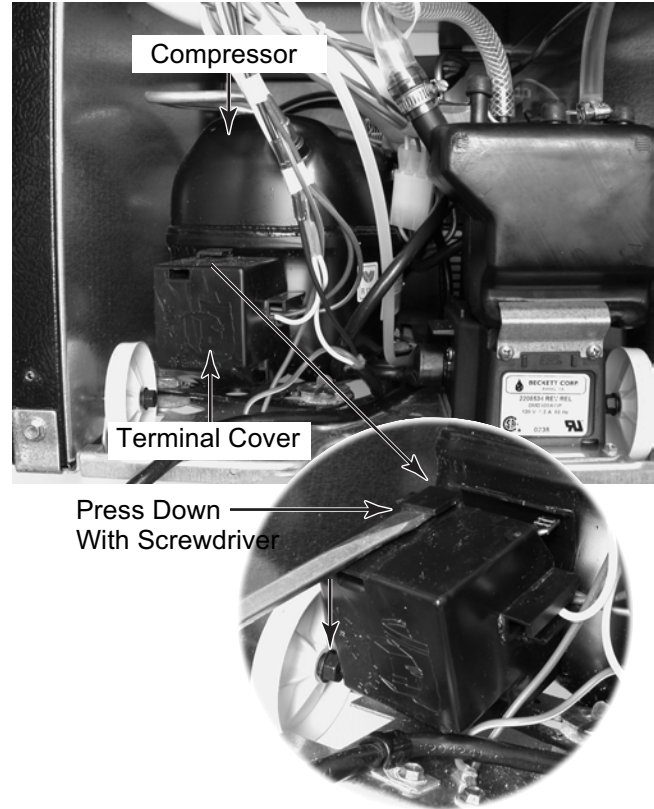

7. Remove the wires from the ground terminal, the overload protector terminal, and the relay terminal.
8. Pull the overload protector and relay from the compressor pins.

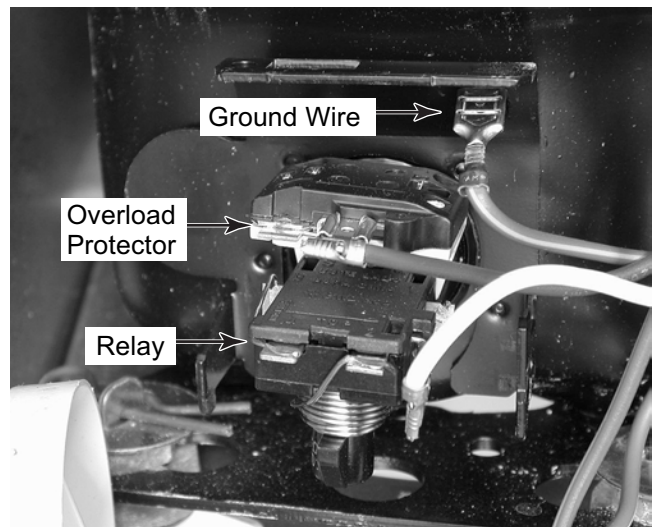

- Pull the two clips off the rear studs of the compressor.



- Tip the front of the cabinet back and prop it up (see steps 5 through 11 on pages 4-8 and 4-9 for the procedure).

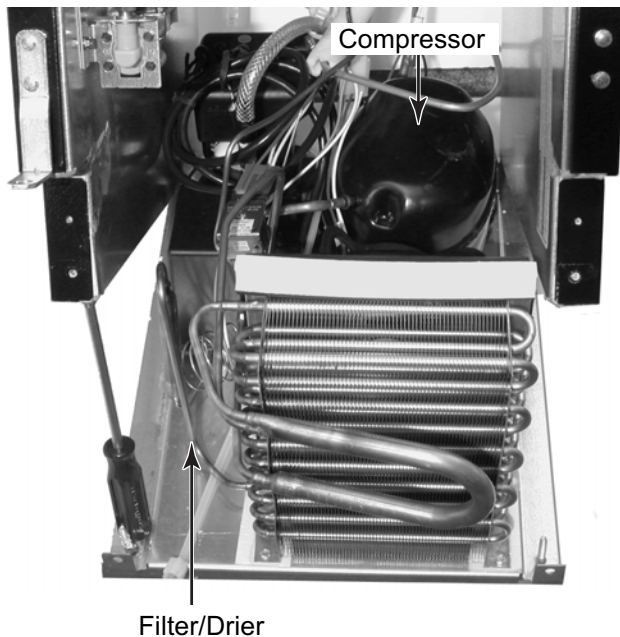

- Access the sealed system and discharge the refrigerant into an approved recovery system.
- Cut the suction and discharge lines from the compressor.
- Cut the filter/drier from the system (do not use a torch to remove the filter/drier).
- Unbraid the compressor suction and discharge joints from the tubing.

- Pull the two clips off the front compressor mounting studs.
- Lift the compressor off the four mounting studs and remove it from the unit. Remove the four metal spacers and rubber isolators from the compressor stud locations.

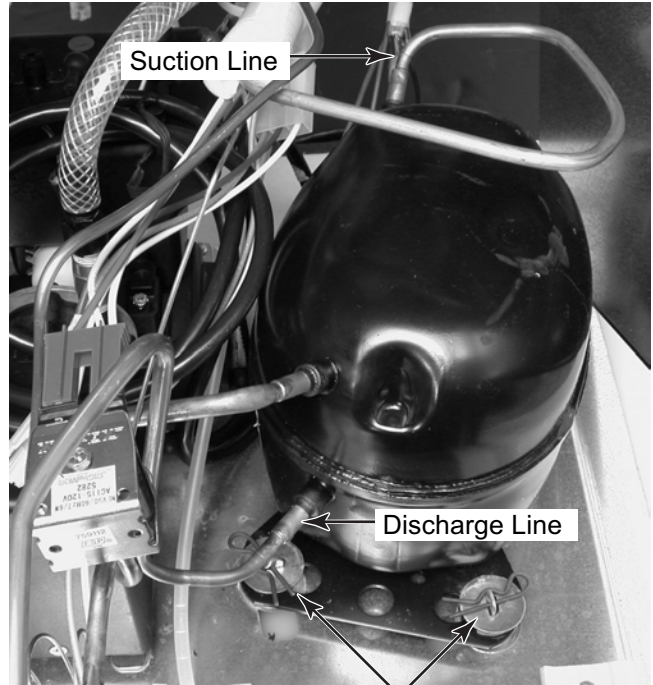

2 Clips, Metal Spacers, & Rubber Isolators

⚠ WARNING



Electrical Shock Hazard

Connect green ground wire to ground terminal.

Failure to do so can result in death or electrical shock.

Perform the following steps after installing the new compressor.

- Install the overload protector and relay on the compressor pins.
- Connect the wires to the ground terminal, the overload protector terminal, and the relay terminal.

REMOVING THE INTERNAL DRAIN PUMP (ONLY ON SOME MODELS)

! WARNING



Electrical Shock Hazard

Disconnect power before servicing.

Replace all parts and panels before operating.

Failure to do so can result in death or electrical shock.

1. Unplug ice maker or disconnect power.
2. Remove the ice from the storage bin.
3. Disconnect the water and drain lines from the ice maker and remove the unit from its installation.
4. At the rear of the unit, remove the four screws from the unit compartment cover and remove the cover.

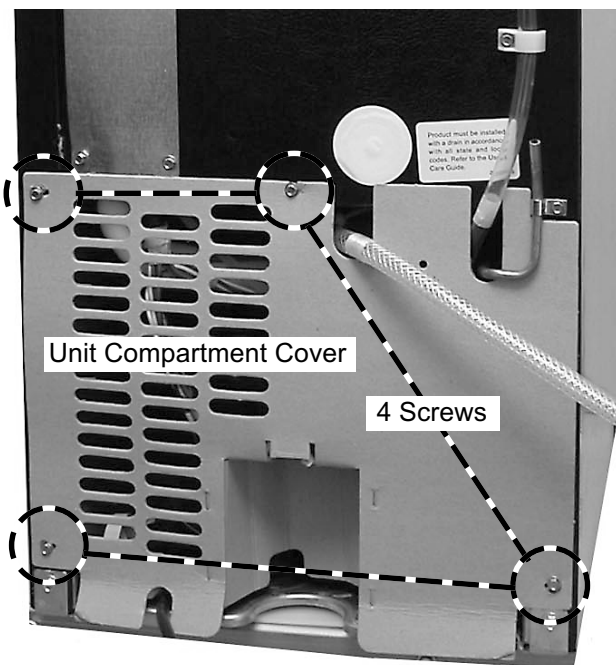

5. Loosen the clamps and pull the ends of the three water lines from the internal drain pump.
6. Disconnect the power cord plug from the internal drain pump.
7. Remove the two mounting screws from the internal drain pump.

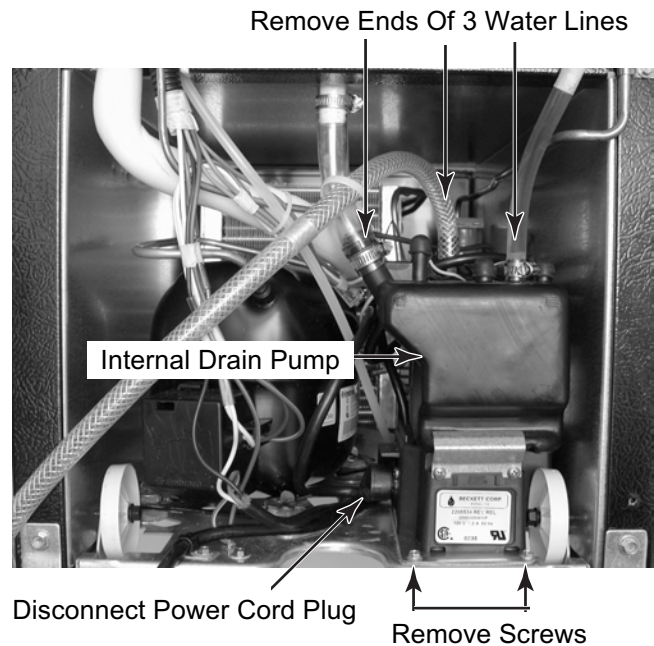

8. Remove the internal drain pump from the unit.

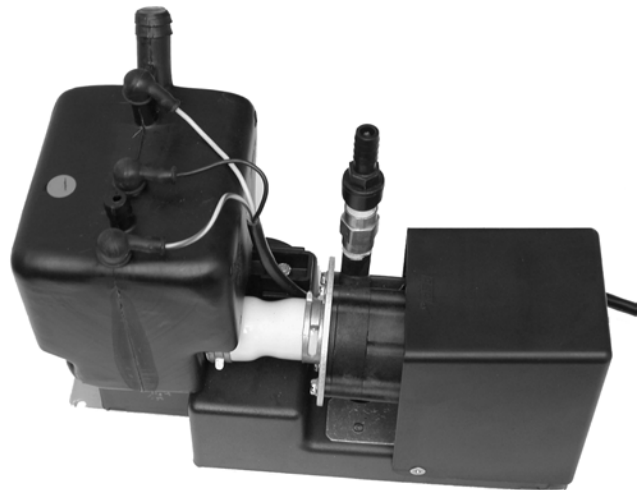

REMOVING THE ICE MAKER DOOR & GASKET (15" MODELS)

1. To remove the door, remove the top door screw from the ice maker door, and pull the door off the bottom hinge.



2. To remove the door gasket:
 - a) Open the ice maker door.
 - b) Pull the gasket out of the door track.
NOTE: Be sure to check the new gasket for a proper seal after you install it.



REMOVING THE ICE MAKER DOOR & GASKET (18" MODELS)

The 18" Ice Maker has a spring-loaded, drop-down door. Since the door design is somewhat unique, accessing procedures are included below.

1. Remove the two top and two bottom screws from the grille and remove it from the front of the ice maker.

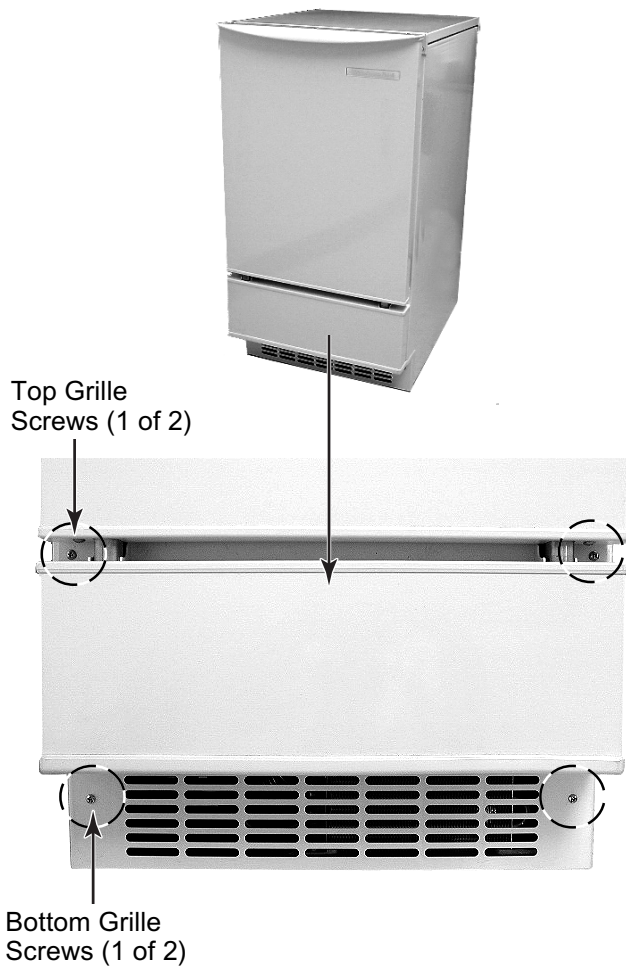

2. Remove the end of the spring from the door bracket and the screw from the bottom of the door hinge.

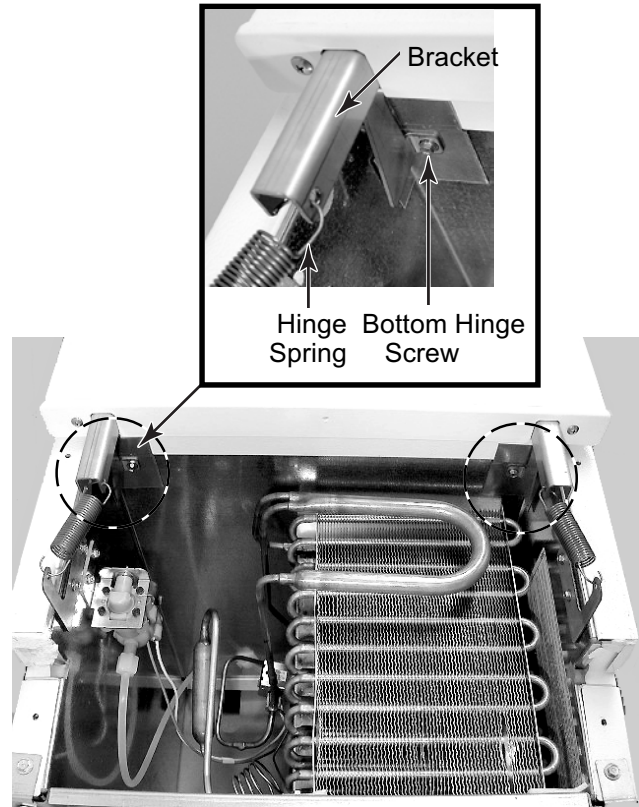

3. Open the ice maker door and remove the four front hinge screws (2 per hinge) and remove the door. NOTE: Support the door while you remove the screws to prevent it from falling off the unit.

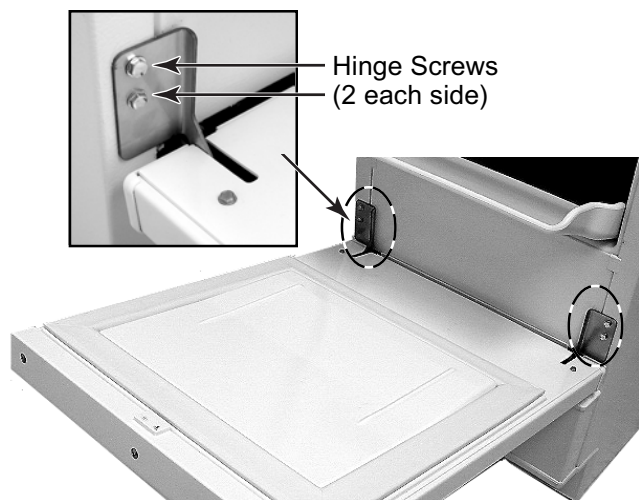

4. Remove the two screws from the bottom door cap.



5. Remove the three screws from the door handle and the top door cap and remove the handle and cap from the door.

Handle & Cap Screw (1 of 3)



Slide Cap Off Door

6. Peel the gasket from the grooves in the door and remove the gasket.

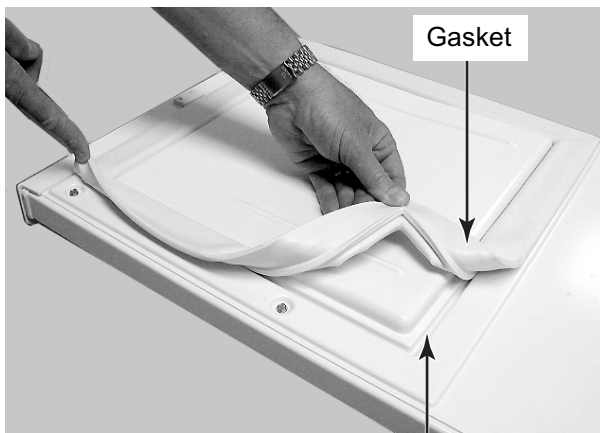

Door Channel

7. Remove the six screws from the inner door panel and remove the panel.

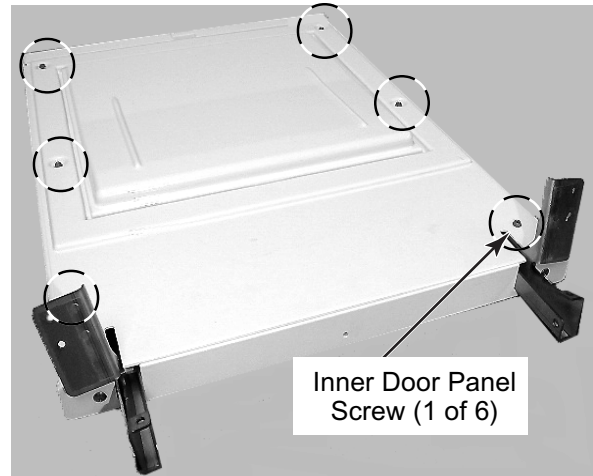

8. Slide the door insulation out of the top of the outer door panel.

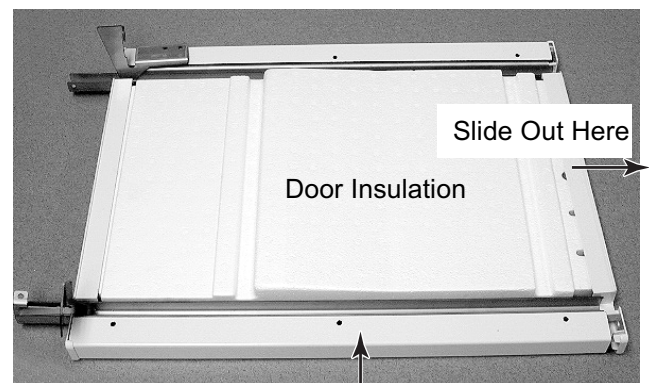

Outer Door Panel

Continued on the next page.

9. Slide the bottom door cap and channel supports out of the outer door panel.

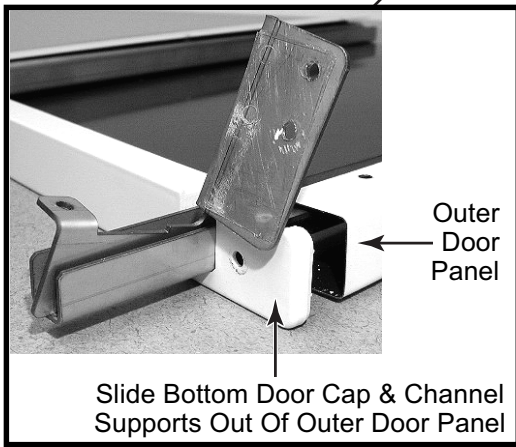
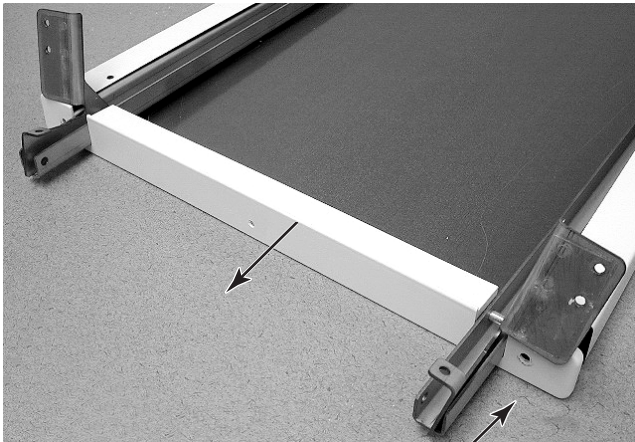

10. Slide the bottom door cap off the channel supports.

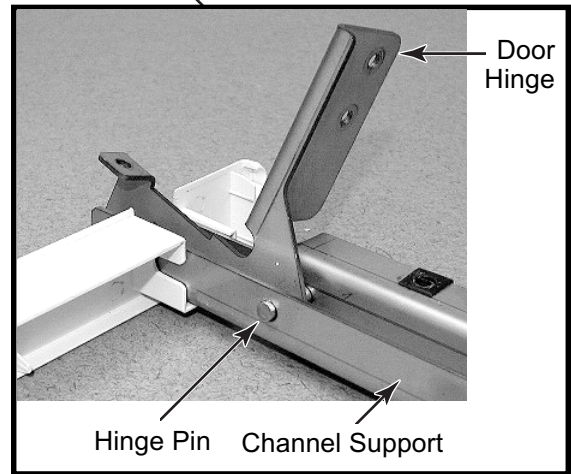
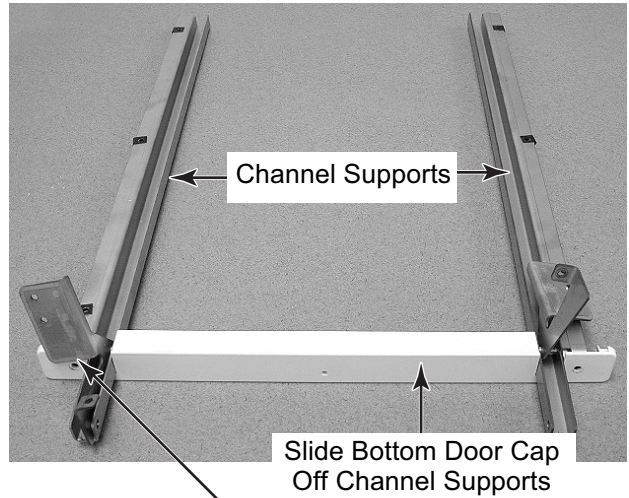

11. To remove the door hinge, pull the hinge pin out of the channel support and remove the hinge.

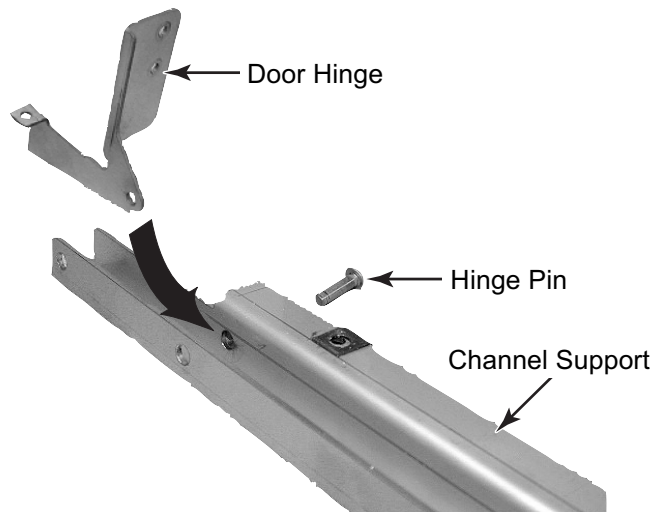

REASSEMBLY NOTES:

1. To reassemble the unit, reverse the disassembly procedure.
2. Slide the edge of the outer door panel between the tabs and the inside edge of the top door cap.

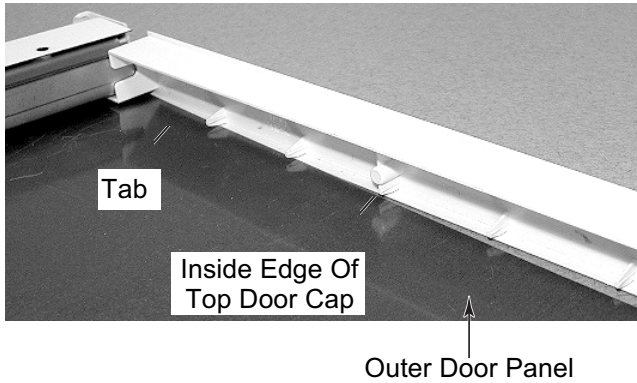

3. When you reinstall the inner door panel, slide the edge under the door handle, as shown below.

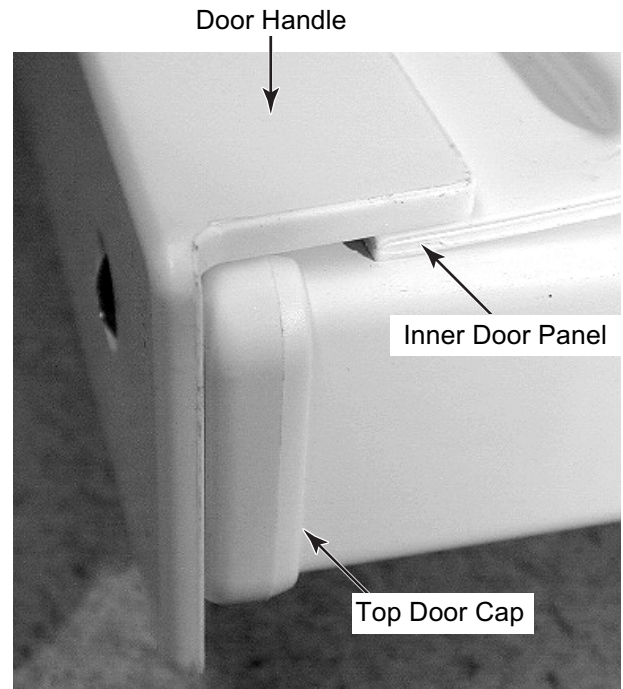

4. Before you reinstall the grille, position the insulation pads and the air block as shown below.

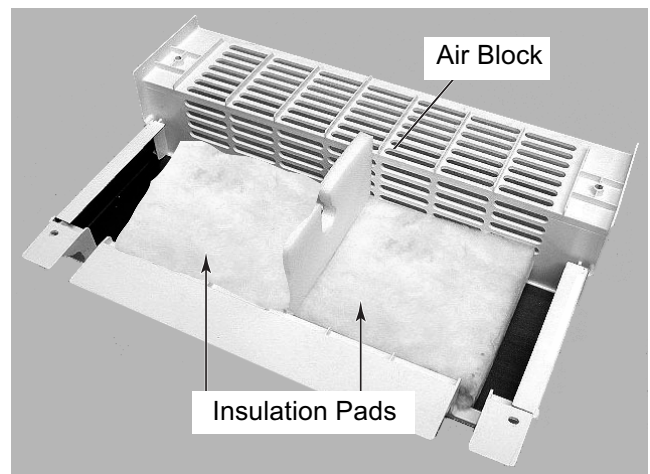

— NOTES —

COMPONENT TESTING

Before testing any of the components, perform the following checks:

- Control failure can be the result of corrosion on connectors. Therefore, disconnecting and reconnecting wires will be necessary throughout test procedures.
- All tests/checks should be made with a VOM or DVM having a sensitivity of 20,000 ohms-per-volt DC, or greater.
- Check all connections before replacing components, looking for broken or loose wires, failed terminals, or wires not pressed into connectors far enough.
- Resistance checks must be made with power cord unplugged from outlet, and with wiring harness or connectors disconnected.



⚠ WARNING

Electrical Shock Hazard

Disconnect power before servicing.

Replace all parts and panels before operating.

Failure to do so can result in death or electrical shock.

BIN THERMISTOR



Refer to page 4-2 for the procedure for servicing the bin thermistor.

1. Unplug ice maker or disconnect power.
2. Set the ohmmeter to the appropriate scale.
3. For the most accurate measurement, immerse the thermistor in ice water for 5 minutes, then use the 32°F/0°C reading in the chart.
4. Touch the ohmmeter test leads to the two bin thermistor connectors. The meter should indicate as shown in the following chart.

| Sensor Temperature °F (°C) | Resistance Ω |
|----------------------------|-----------------|
| 0 (-18) | 81,715 - 99,874 |
| 10 (-12) | 59,422 - 72,627 |
| 32 (0) | 30,266 - 36,992 |
| 50 (10) | 18,219 - 22,267 |
| 70 (21) | 10,280 - 12,564 |
| 90 (32) | 6,387 - 7,807 |

EVAPORATOR THERMISTOR



Refer to page 4-2 for the procedure for servicing the evaporator thermistor.

1. Unplug ice maker or disconnect power.
2. Set the ohmmeter to the appropriate scale.
3. For the most accurate measurement, immerse the thermistor in ice water for 5 minutes, then use the 32°F/0°C reading in the chart.
4. Touch the ohmmeter test leads to the two evaporator thermistor connectors. The meter should indicate as shown in the following chart.

| Sensor Temperature °F (°C) | Resistance Ω |
|----------------------------|-----------------|
| 0 (-18) | 81,715 - 99,874 |
| 10 (-12) | 59,422 - 72,627 |
| 32 (0) | 30,266 - 36,992 |
| 50 (10) | 18,219 - 22,267 |
| 70 (21) | 10,280 - 12,564 |
| 90 (32) | 6,387 - 7,807 |



⚠️ WARNING

Electrical Shock Hazard

Disconnect power before servicing.

Replace all parts and panels before operating.

Failure to do so can result in death or electrical shock.

CUTTER GRID

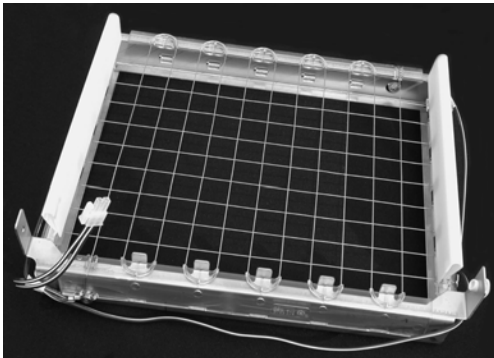

Refer to page 4-2 for the procedure for servicing the cutter grid.

1. Unplug ice maker or disconnect power.
2. Set the ohmmeter to the R x 1 scale.
3. Touch the ohmmeter test leads to the pins of the cutter grid 2-wire connector. The meter should indicate 4 to 5 Ω .

CUTTER GRID TRANSFORMER

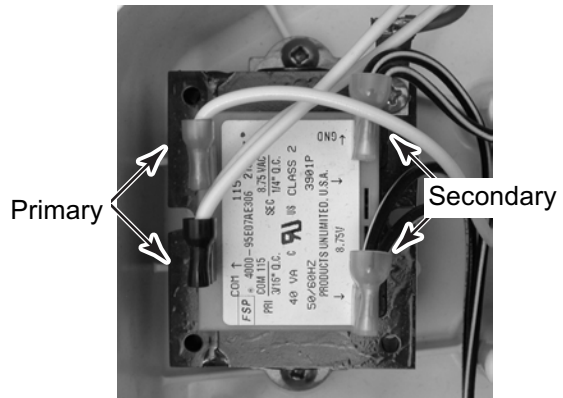

Refer to page 4-5 for the procedure for servicing the cutter grid transformer.

1. Unplug ice maker or disconnect power.
2. Set the ohmmeter to the R x 1 scale.
3. Touch the ohmmeter test leads to the primary terminals of the cutter grid transformer. The meter should indicate between 12 and 18 Ω .
4. Touch the ohmmeter test leads to the secondary terminals of the cutter grid transformer. The meter should indicate less than 1 Ω .



⚠️ WARNING

Electrical Shock Hazard

Disconnect power before servicing.

Replace all parts and panels before operating.

Failure to do so can result in death or electrical shock.

WATER RECIRCULATION PUMP



Refer to page 4-7 for the procedure for servicing the water recirculation pump.

1. Unplug ice maker or disconnect power.
2. Set the ohmmeter to the R x 100 scale.
3. Touch the ohmmeter test leads to the outside water recirculation pump wire connector pins. The meter should indicate between 17 and 23 Ω .

CONDENSER FAN MOTOR



Refer to page 4-8 for the procedure for servicing the condenser fan motor.

1. Unplug ice maker or disconnect power.
2. Set the ohmmeter to the R x 1 scale.
3. Touch the ohmmeter test leads to the outside pins of the condenser fan motor connector. The meter should indicate between 265 and 285 Ω .



⚠️ WARNING

Electrical Shock Hazard

Disconnect power before servicing.

Replace all parts and panels before operating.

Failure to do so can result in death or electrical shock.

WATER INLET VALVE SOLENOID

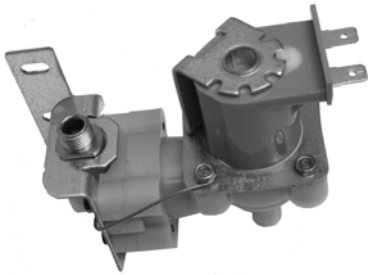

Refer to page 4-15 for the procedure for servicing the water inlet valve.

1. Unplug ice maker or disconnect power.
2. Set the ohmmeter to the R x 100 scale.
3. Touch the ohmmeter test leads to the water inlet valve solenoid terminals. The meter should indicate between 2650 and 2750 Ω .

HOT GAS VALVE SOLENOID



Refer to page 4-16 for the procedure for servicing the hot gas valve solenoid.

1. Unplug ice maker or disconnect power.
2. Set the ohmmeter to the R x 1 scale.
3. Touch the ohmmeter test leads to the pins of the hot gas valve solenoid 2-wire connector. The meter should indicate between 365 and 390 Ω .



⚠️ WARNING

Electrical Shock Hazard

Disconnect power before servicing.
Replace all parts and panels before operating.
Failure to do so can result in death or electrical shock.

COMPRESSOR, OVERLOAD PROTECTOR, & RELAY

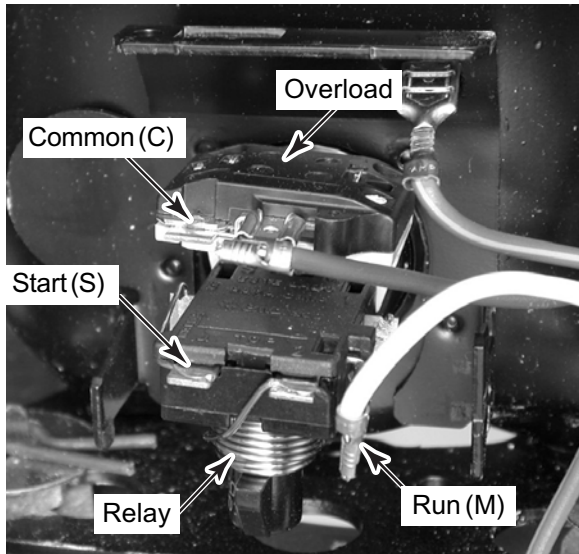

Refer to page 4-18 for the procedure for servicing the compressor.

1. Unplug ice maker or disconnect power.
2. Set the ohmmeter to the R x 1 scale.

3. To test the compressor windings:

- a) Touch one of the ohmmeter test leads to the Common (C) pin, and the other lead to the Start (S) pin. The meter should indicate between 8 and 11 Ω .
- b) Touch one of the ohmmeter test leads to the Common (C) pin, and the other lead to the Run (M) pin. The meter should indicate between 2 and 3 Ω .

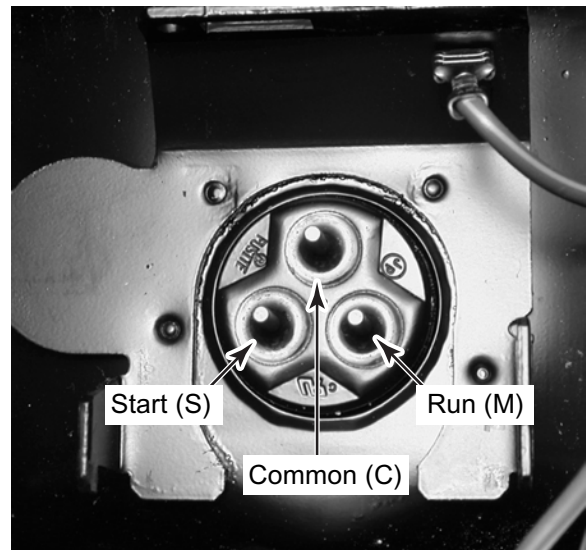

Continued on the next page.

4. **To test the relay:**

- a) Position the relay with the coil facing down, as shown below.
- b) Insert the tip on one of the ohmmeter test leads into the Run (M) pin socket, and touch the other ohmmeter lead to the spade terminal. The meter should indicate a closed circuit (0Ω).
- c) Move the tip of the ohmmeter test lead from the spade terminal into the Start (S) pin socket. Leave the other ohmmeter lead at the Run (M) location. The meter should indicate an open circuit (infinite).

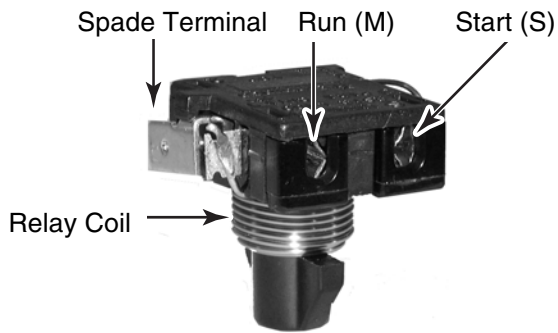

- d) Turn the relay over so that the coil faces up, as shown below.
- e) With the tip of the ohmmeter test leads at the Start (S) and Run (M) pin sockets, the meter should indicate a closed circuit (0Ω).

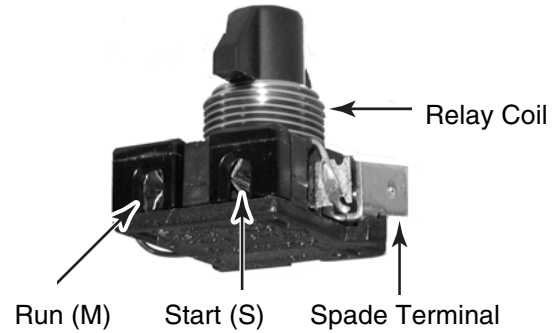



⚠️ WARNING

Electrical Shock Hazard

**Disconnect power before servicing.
Replace all parts and panels before operating.
Failure to do so can result in death or electrical shock.**

PUSHBUTTON SWITCH ASSEMBLY

Refer to page 4-5 for the procedure for servicing the pushbutton switch assembly.

1. Unplug ice maker or disconnect power.
2. Set the ohmmeter to the R x 1 scale.

3. Disconnect the four wire connectors from the pushbutton switch assembly.
4. Touch the ohmmeter test leads to the test points shown in the chart below. The meter reading should indicate as shown.

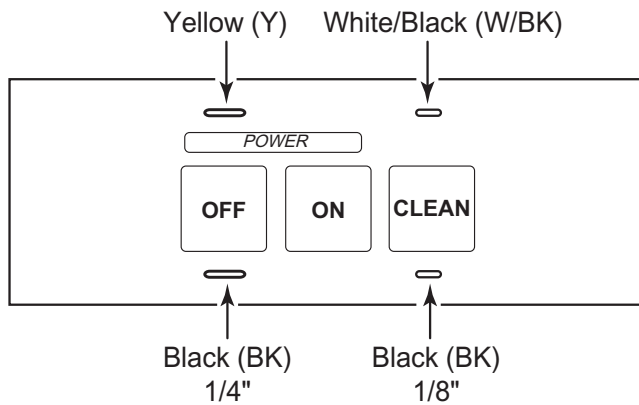

| Switch Position | Test Point | Reading |
|-----------------|------------------|-----------------|
| OFF | Y - BK (1/4") | Open (infinite) |
| | W/BK - BK (1/8") | Open (infinite) |
| ON | Y - BK (1/4") | Closed (0 Ω) |
| | W/BK - BK (1/8") | Open (infinite) |
| CLEAN | Y - BK (1/4") | Closed (0 Ω) |
| | W/BK - BK (1/8") | Closed (0 Ω) |

— NOTES —

DIAGNOSIS & TROUBLESHOOTING

WATER AND ITS EFFECT ON MAKING ICE

Quality ice is defined as solid, clear, and free of taste or odor. All ice makers can provide this type of ice only if the water used to produce the

ice is pure, and free of mineral contamination. The following charts show some of the problems that can affect ice production.

EFFECT ON ICE QUALITY

| INGREDIENT | EFFECT | CORRECTION |
|--|--|--|
| Algae | Objectionable Taste and Odor | Carbon Filter |
| Minerals: Sodium Potassium Magnesium Calcium | Cloudy Ice Slow Cutting Refreezing | <ol style="list-style-type: none"> 1. Check for water flow restriction 2. Polyphosphate feeder or water softener 3. Change water source |

EFFECT ON ICE MAKER

| INGREDIENT | EFFECT | CORRECTION |
|---|----------------------------|---|
| Iron Chlorine Manganese | Staining (Aesthetics only) | <ol style="list-style-type: none"> 1. Use only Ice Machine Cleaner P/N 8171307 2. Water softener and iron filter |
| Permanent Hardness Calcium or Magnesium Sulfates Chlorides Nitrates | Scale | <ol style="list-style-type: none"> 1. Abrasive cleaning 2. Polyphosphate feeder or water softener reduces or eliminates need for abrasive cleaning |
| Temporary Hardness Calcium or Magnesium Carbonates | Scale | <ol style="list-style-type: none"> 1. Use only Ice Machine Cleaner P/N 8171307 2. Polyphosphate feeder or water softener reduces frequency of cleaning by 50% |

RECOMMENDATIONS:

Water softeners or polyphosphate feeders are not cure-alls, but do reduce and, in some cases, prevent scale buildup. Use only Ice Maker Cleaner (P/N 8171307) if there is scale buildup on evaporator plate or in water hoses.

CAUTION: Some polyphosphate feeders cause slime buildup. Their use in low mineral content water should be carefully considered.

NOTE: Reverse Osmosis filters are NOT RECOMMENDED with this unit. These filters can limit the water flow to the unit and limit its capacity to produce sufficient ice.

Water Hardness Test Kit: A Water Hardness Test Kit (P/N 4171690) is available from FSP Parts Distribution.

TROUBLESHOOTING CHART

| Problem | Probable Cause | Test Procedure-Action |
|--|---|---|
| Will not run | No power at wall outlet | Check circuit breaker/fuses |
| | No power at drain pump power outlet | Check for kinked drain hose, blocked screen or blocked vent outlet or hose. |
| | Open selector switch | Check for continuity from terminals 1 - 2 on selector switch |
| | Loose connections at selector switch or control board | Repair connections |
| | No power through power cord | Check continuity of power cord and replace if open |
| | Room temperature below 55°F (13°C) | Bin thermistor has unit shut off Customer Instruction |
| | Ice touching bin thermistor | Normal operation |
| Will not make ice Water reservoir is empty Evaporator is cold with thin or no ice slab | Water supply turned off | Turn on water supply |
| | Loose or missing reservoir cap | Tighten or replace |
| | Water slide return tube out of reservoir | Reposition tube |
| | Inlet tube out of position and missing reservoir | Reposition tube |
| | Water inlet tube frozen near evaporator | Thaw and reposition tube |
| | Defective inlet water valve | Test and repair or replace |
| | An ice slab only partially released from evaporator and water was bridged down into the bin | Look for interference with cutter grid and clean the evaporator plate (see procedure on page 8-1) |

| Problem | Probable Cause | Test Procedure-Action |
|---|---|--|
| Will not make ice Water reservoir is empty. Evaporator is cold with 3/4" thick or larger ice slab | Slab will not release during harvest due to scale build up | Clean the evaporator plate (see procedure on page 8-1) |
| | Defective or disconnected hot gas solenoid | Test and repair or replace |
| | Defective hot gas valve | Test and repair or replace |
| | Room temperature over 100°F (38°C) | Customer instruction |
| Will not make ice Water reservoir is full Evaporator is cold with thin/partial/irregular or no ice slab | Seeping water valve Condenser is hot | Replace water valve |
| | Partial refrigerant leak or restriction (U shaped slab) | Check for leak/restriction and repair or replace defective component |
| | Blocked condenser or stalled fan motor | Clean condenser, repair or replace motor |
| | Tube not attached to outlet of recirculation pump | Reattach tube |
| | Defective recirculating pump | Repair or replace the pump motor assembly |
| | Partially blocked water distributor | Clean distributor and evaporator |
| Will not make ice Water reservoir is full Evaporator is warm | Compressor is not running | Test compressor, relay and overload |
| | Blocked condenser or stalled fan motor | Clean condenser, repair or replace motor |
| | Unit is in the startup mode | Wait 5 minutes and recheck |
| Poor ice production | Room temperature below 55°F (13°C) | Bin thermistor has unit shut off Customer Instruction |
| | Seeping water valve Condenser is hot | Replace water valve |
| | Slow or defective drain or drain pump causing water to back up into the bin | Repair or replace drain or drain pump |

| Problem | Probable Cause | Test Procedure-Action |
|---|--|---|
| Too much ice in bin | Defective bin thermistor | Replace |
| Noisy | Banging sound | The slab dropping off the plate and ice dropping from the cutter grid into an empty bin are normal sounds |
| | Grinding, cavitating sound | The reservoir is empty. Look for a partially released slab, interference with cutter grid etc and clean the evaporator plate, (see procedure on page 8-1) |
| | Grinding, cavitating sound from recirculation pump | If the reservoir is full replace the pump |
| | Noisy drain pump | Repair or replace |
| Ice freezing together in the bin | Normal | This is normal with low customer useage |
| Cloudy, soft, thin, or poor tasting ice | Poor water quality | See chart on page 6-1 |
| Clean light is flashing (see Failure Mode on page 6-10) | Open or disconnected bin thermistor or thermistor wiring | Test thermistor & wiring harness or reconnect |
| | Defective, loose or mispositioned evaporator thermistor | Test thermistor & wiring harness or reconnect |

DIAGNOSTIC FLOW CHART FOR ICE MAKER CONTROL BOARD #6100499

Before using this chart, confirm that you have electronic control board #6100499. Look for the part number on the control, or use the following procedure:

1. Disconnect the bin thermistor.
2. Place the unit into the Clean mode.
3. If the Clean LED flashes 2 times, it is the new control. The old control will not flash the LED.

OVERVIEW

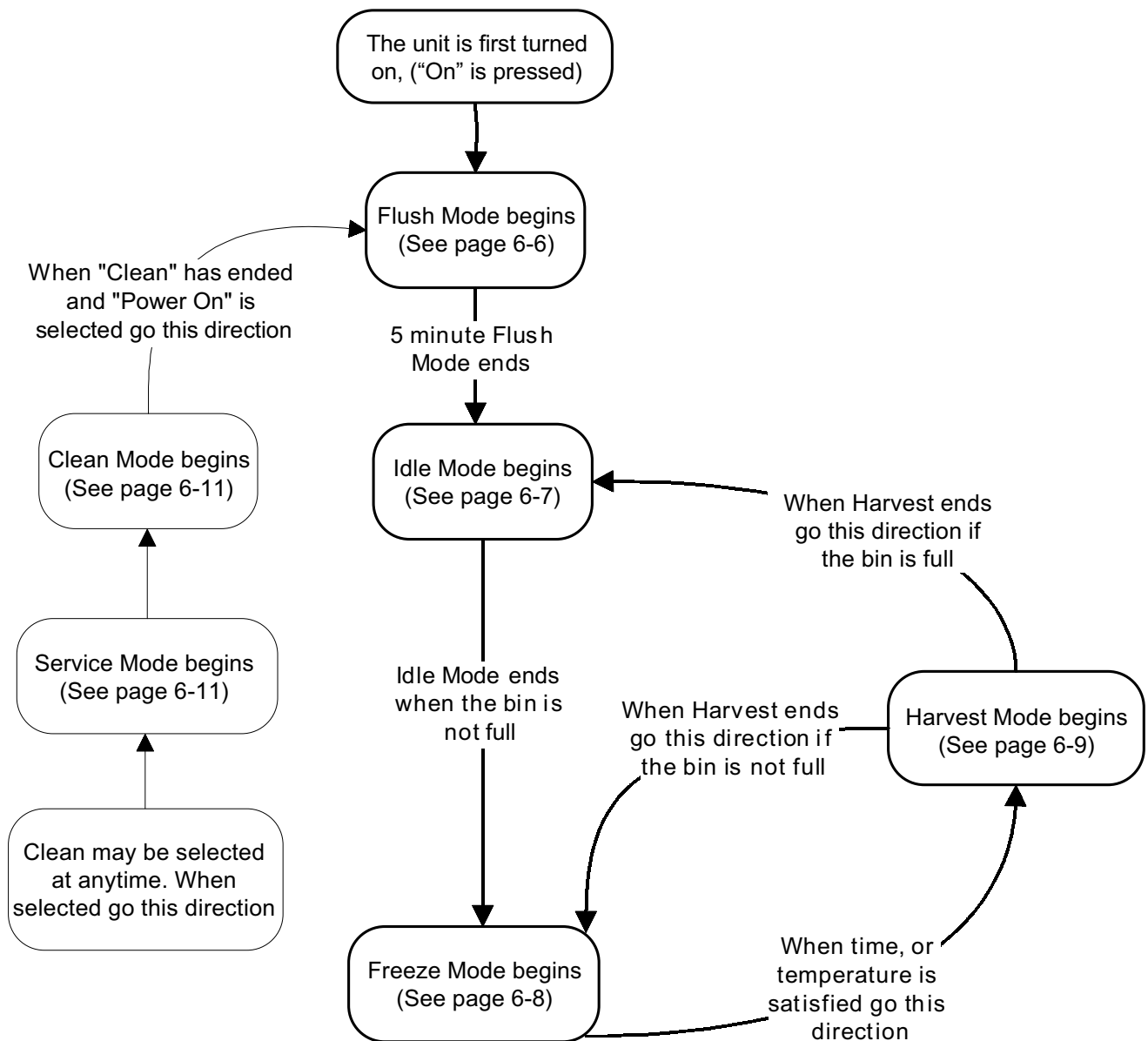

Flush Mode (5 minutes)

The Flush Mode begins every time the pushbutton switch is changed to “On” from “Off” or “Clean.” This will be the initial time the unit is turned on, or when the unit is turned on after the completion of a Clean Cycle, or (drain pump model only) when operation resumes after the unit is shut down by the drain pump.

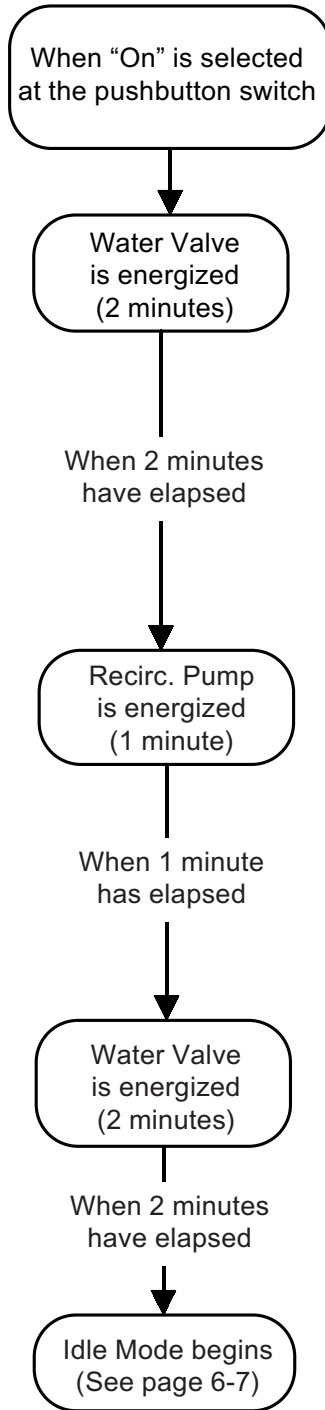

Idle Mode: Time in this mode is dependent on the temperature at the bin thermistor.

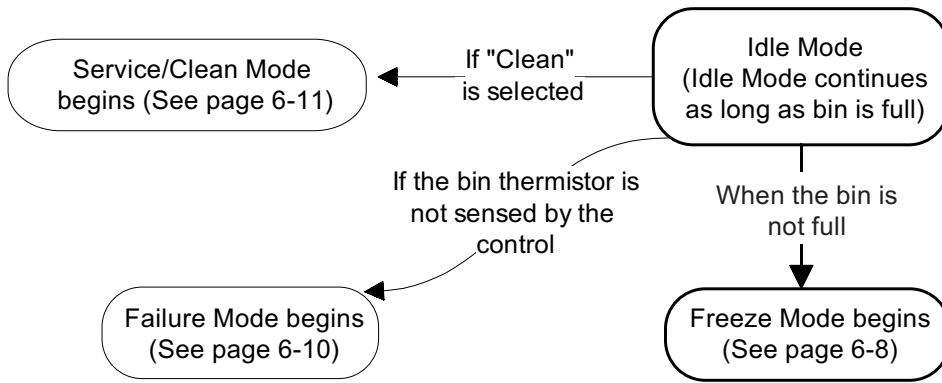

NOTE: "Bin Full" setpoint is 38°F. The unit will stay in the "Idle Mode" as long as the ice in the bin touches the bin thermistor and keeps it lower than 38°F.

Freeze Mode: 15 minutes, 30 seconds minimum* to 25 minutes, 30 seconds maximum***.

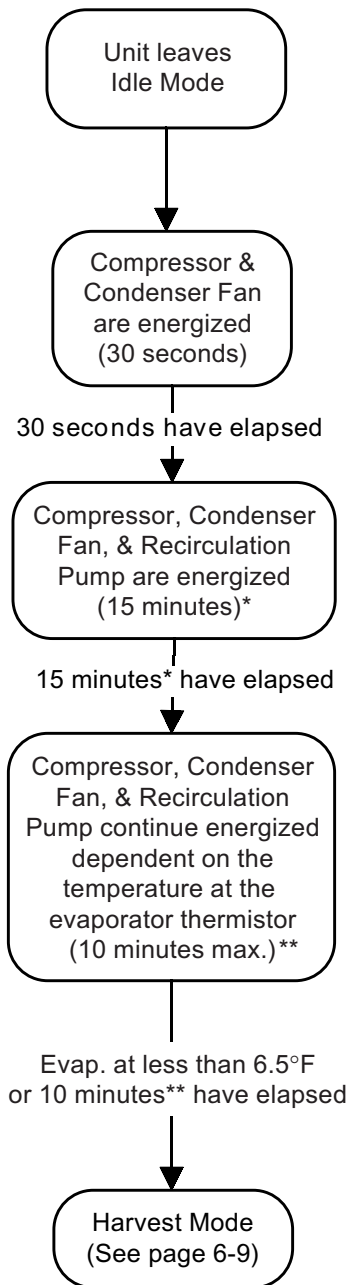

NOTE: Control boards with Code Date MGR/0245, (45th week, 2002), and later, will allow thickness adjustments. Use the following chart to determine the freeze time (see “Adjusting The Ice Thickness” on page 8-3 for more information).

| | | Freeze Mode Time (minutes) | | |
|------------------------------------|------------|----------------------------|--|-------------------------------|
| Jumper at P4 on electronic control | | * Minimum freeze time | ** Maximum additional time (dependent on evap. Thermistor temp.) | *** Total Maximum freeze time |
| Pins 4 & 5 | Thick Ice | 19 | 8 | 27 |
| Pins 2 & 3 (factory default) | Normal Ice | 15 | 10 | 25 |
| Pins 1 & 2 | Thin Ice | 12 | 11 | 23 |

Harvest Mode: 1 to 16 minutes, dependent on the condition of the evaporator thermistor.

NOTE: Each path is possible and acceptable at any temperature range. A typical operation is shown below that may be found at a particular ambient temperature.

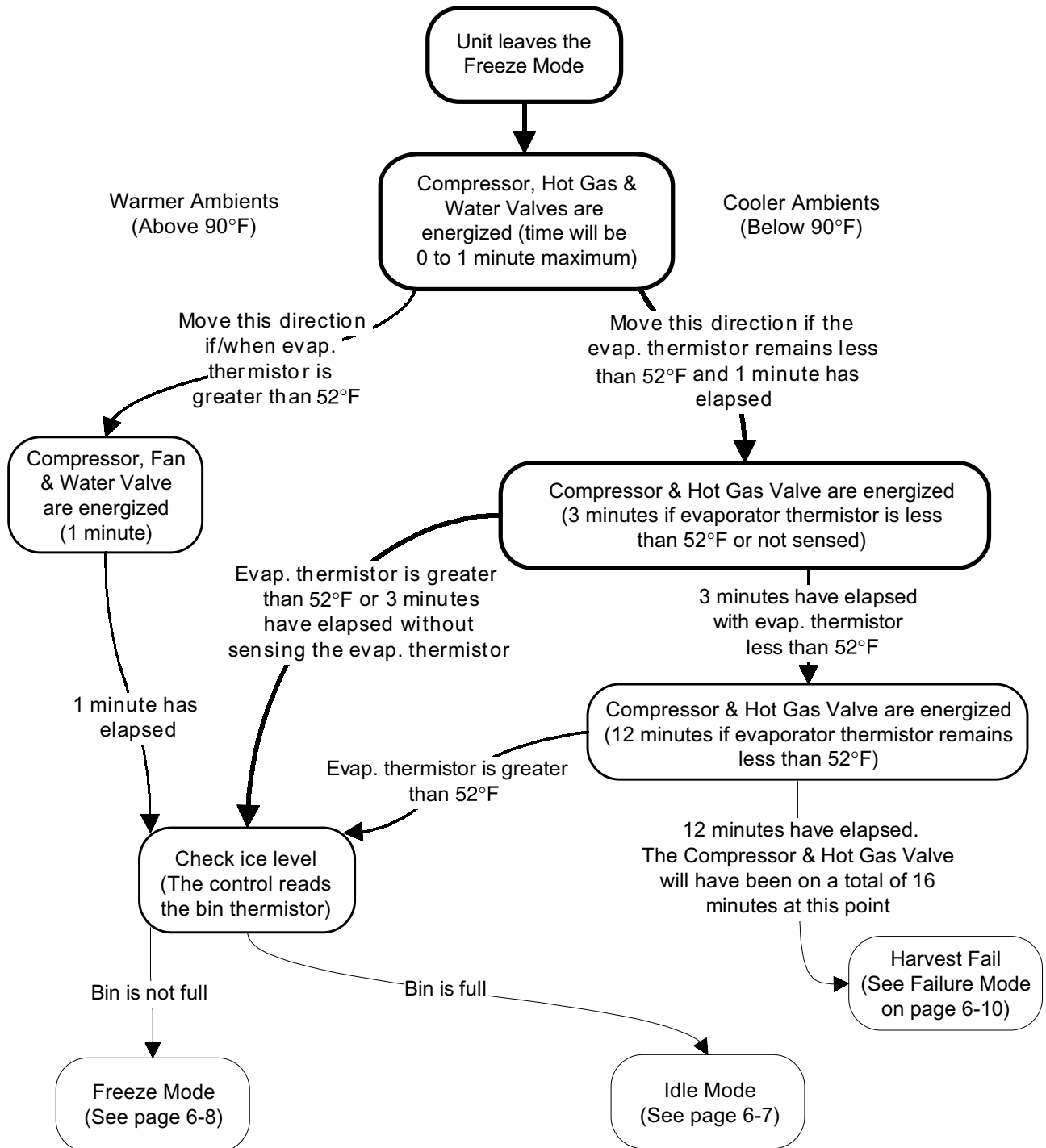

Failure Mode: This mode will last indefinitely until the failure is corrected.

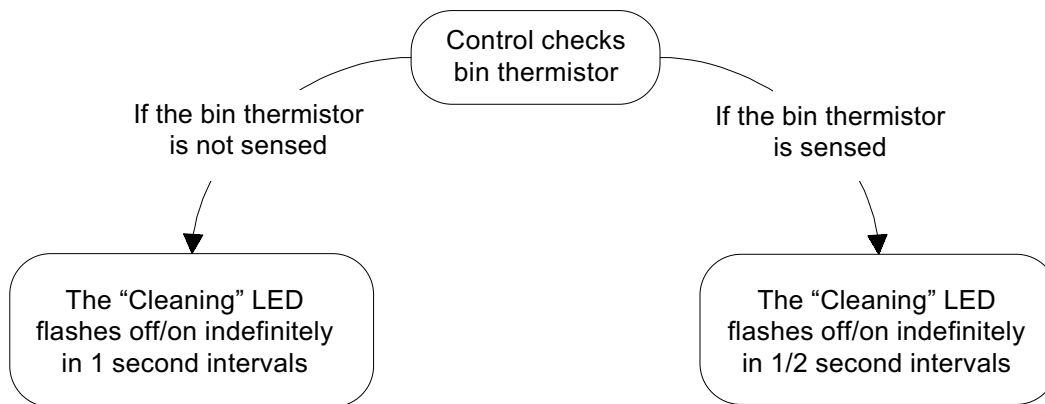

NOTE: If the LED is flashing in 1/2 second intervals, look for an evaporator thermistor that has not reached 52°F. This may be due to a loose or improperly positioned thermistor, a hot gas valve failure, a sealed system leak, or a restriction.

The bin thermistor is constantly checked during Flush, Idle, and Harvest Modes, and at the end of each Freeze Mode. If the LED is flashing in 1 second intervals, look for a disconnected, or an open bin thermistor.

The Clean switch is continually checked during the Failure Mode, and if pressed, the program switches to the Service Mode.

Service/Clean Mode (50 Min., 30 Sec.) The first 30 seconds will be Service (Diagnostics)

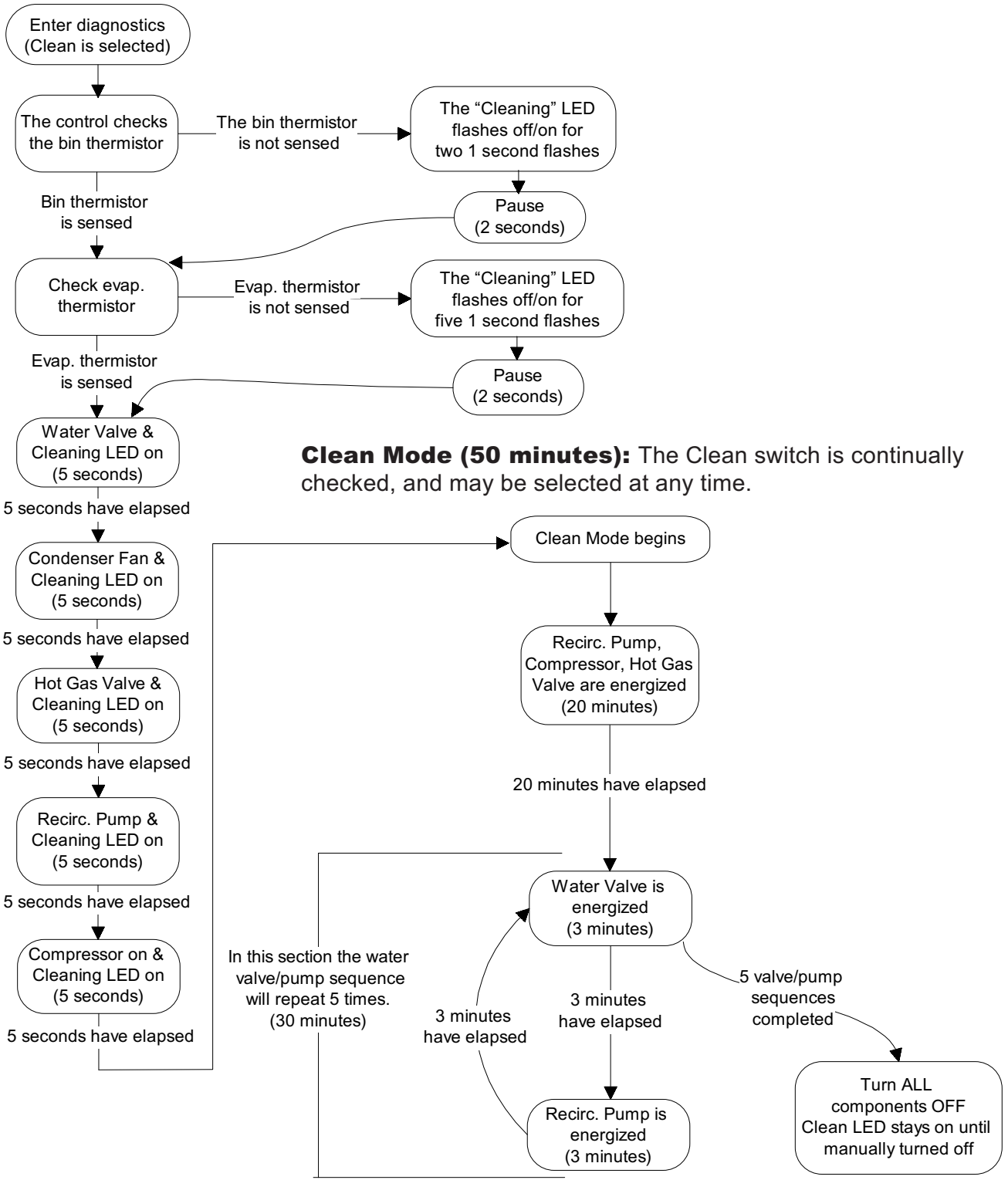

Clean Mode (50 minutes): The Clean switch is continually checked, and may be selected at any time.

NOTE: At the end of the Clean cycle, the unit will stay OFF. The reservoir must be drained prior to restarting the unit.

— NOTES —

WIRING DIAGRAM & STRIP CIRCUITS

WIRING DIAGRAM

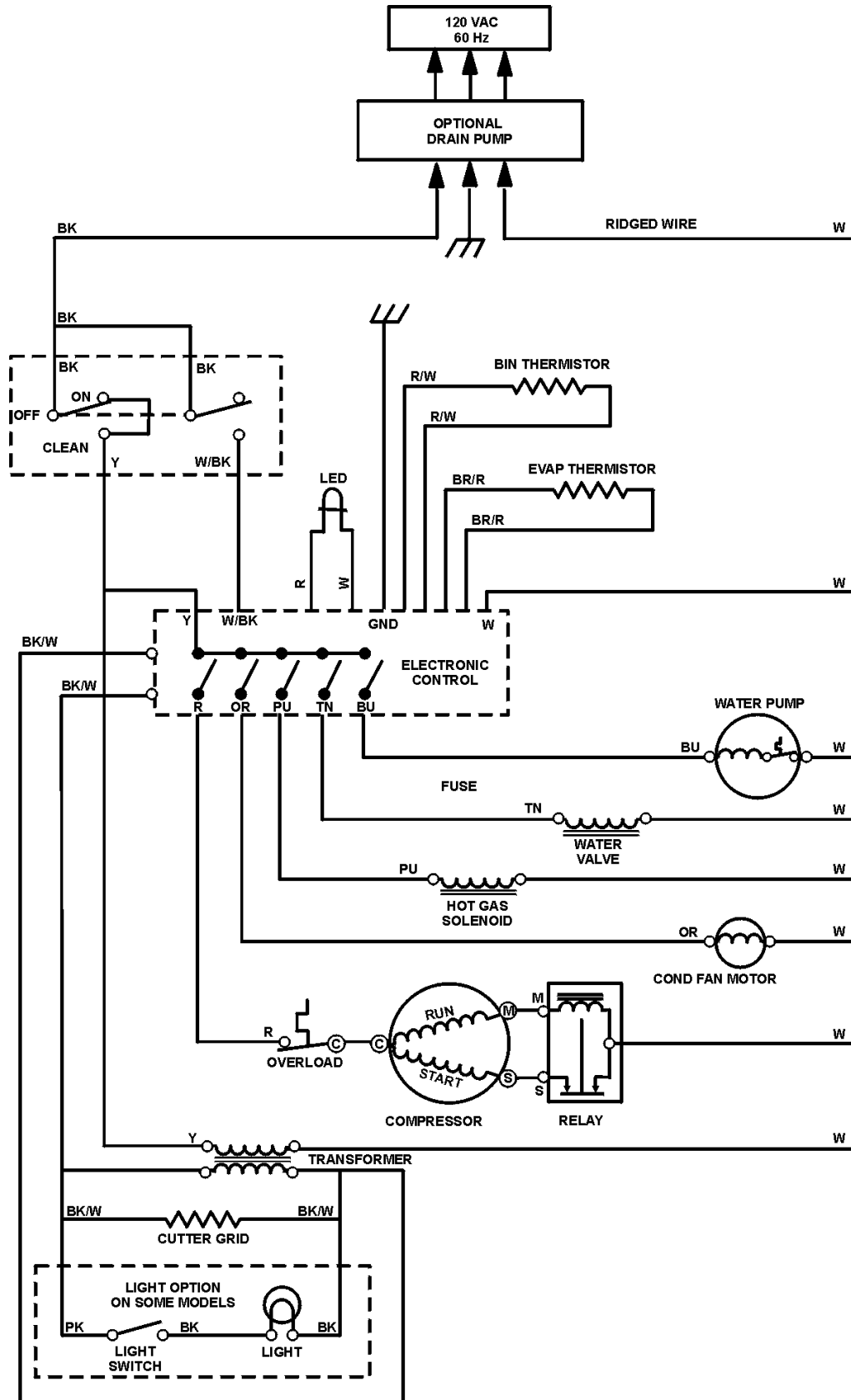

STRIP CIRCUITS

ICE MAKING MODE

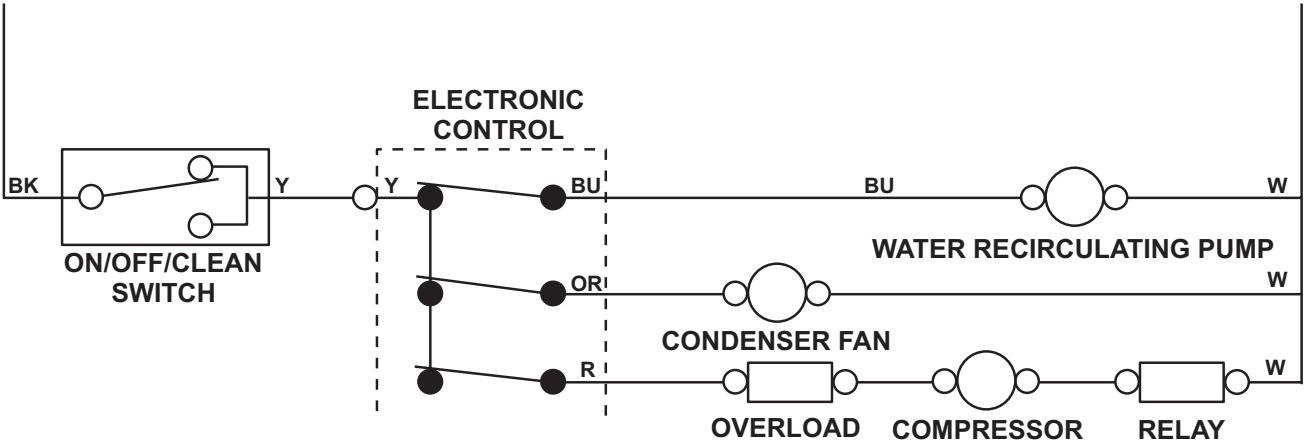

NOTE: If the unit is run through the Ice Making mode with no water running across the evaporator plate, a complete frost pattern will appear.

HARVEST MODE

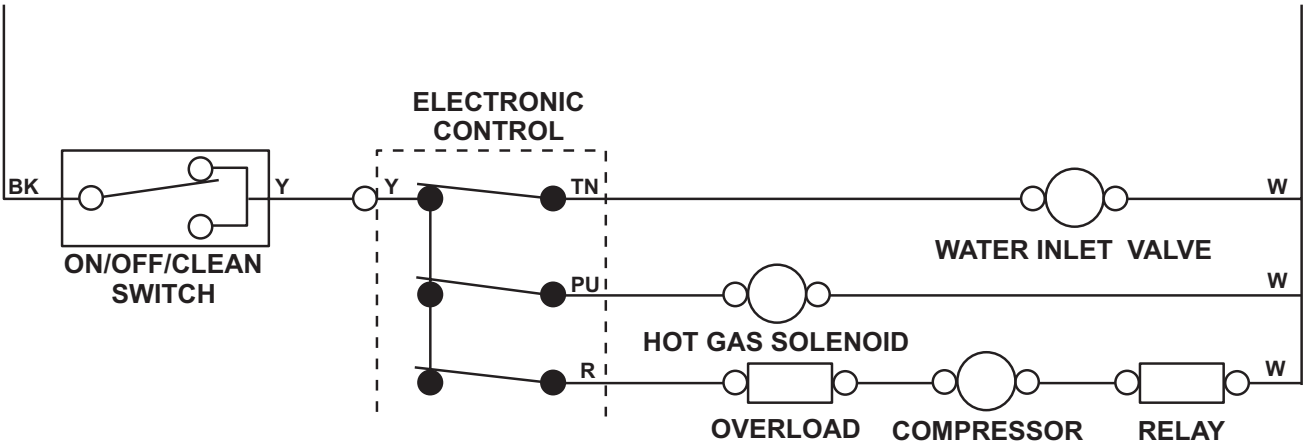

FIRST 25 SECONDS OF DIAGNOSTICS/CLEAN MODE

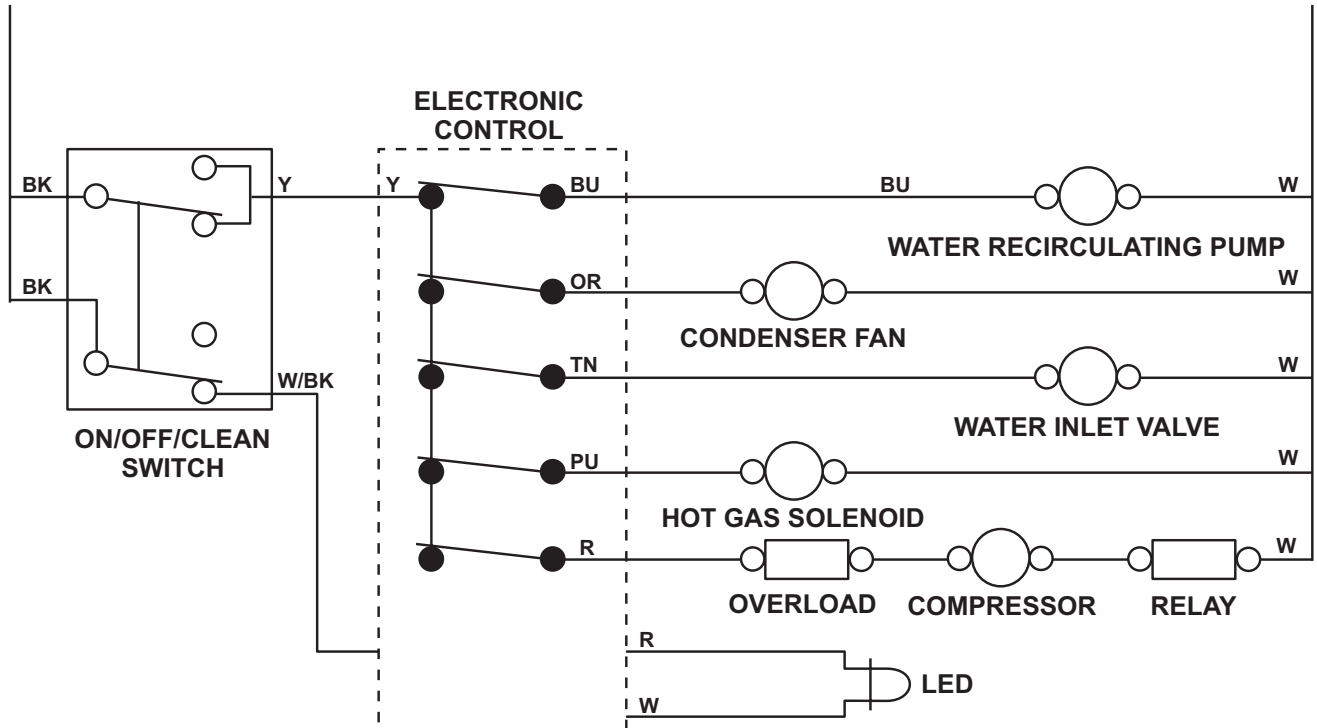

NOTE: Each relay on the electronic control board closes for five seconds in consecutive order. The LED remains On through the entire Diagnostics cycle.

LAST 47 MINUTES OF DIAGNOSTICS/CLEAN MODE

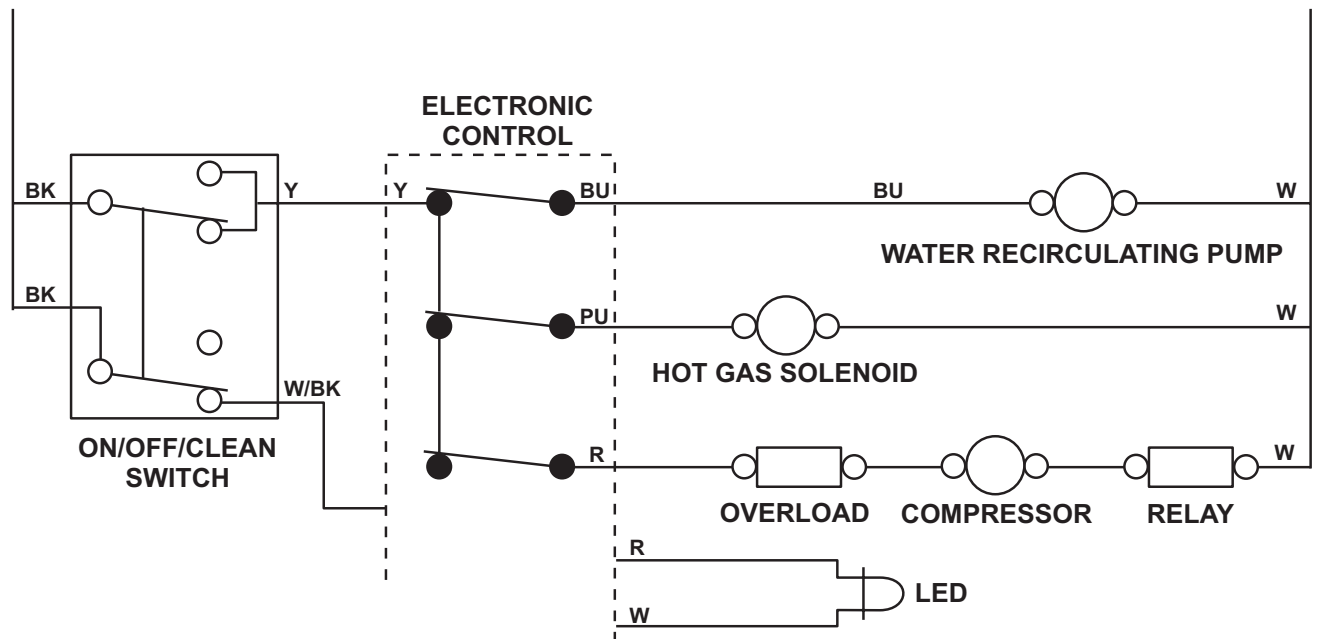

— NOTES —

TECH TIPS

CLEANING THE ICE MAKER

! WARNING



Electrical Shock Hazard
Disconnect power before servicing.
Replace all parts and panels before operating.
Failure to do so can result in death or electrical shock.

NOTES:

- KitchenAid recommends cleaning the ice maker at least once a year. More frequent cleaning may be required in areas that contain heavy amounts of minerals in the water supply.
- Always wear rubber gloves when handling cleaning solutions.

CLEANING THE EVAPORATOR PLATE

NOTE: Use one 16 oz (473 ml) bottle of NUCALGON™ Nickel-Safe Ice Machine Cleaner, Part Number **8171307**. For best performance, do not use any other type of ice machine cleaner in the ice maker.

1. Push the OFF keypad to turn the unit off.
2. For easier access to the evaporator, remove the cutter grid (see page 4-2).
3. Remove the ice from the bin.
4. Unscrew the drain cap from the reservoir and allow the reservoir to drain completely, then reinstall the drain cap.

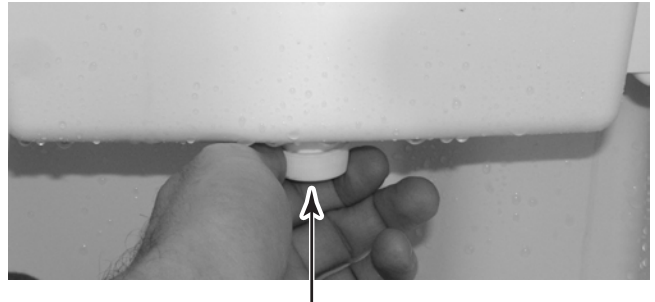

Reservoir Drain Cap

Continued on the next page.

5. Read and follow all of the handling information that was supplied with the ice machine cleaner. **IMPORTANT:** Do not follow the cleaning directions that are printed on the cleaner bottle. Do not use their suggested amounts, but use the entire bottle to clean the unit.
6. Open the bottle and pour a small amount of cleaning solution onto the cleaning brush. **NOTE:** If a brush is not available you may use a Scotch-Brite™ pad.

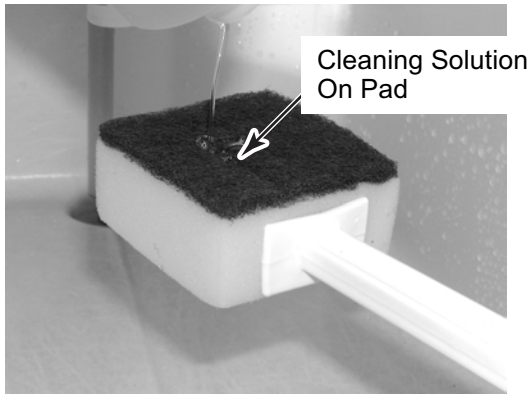

7. Using only front-to-back motions, clean the top of the plate, the sidewalls, and the front edge of the evaporator. The front-to-back motion is important to prevent scratches that could keep the ice slab from sliding off the evaporator plate.

NOTE: More solution may be necessary if there is a large amount of scale buildup on the evaporator. The scrubbing process may take ten minutes or more, depending on the amount of scale buildup on the plate. The entire plate should feel smooth when the cleaning is finished.

Scrub Front-To-Back

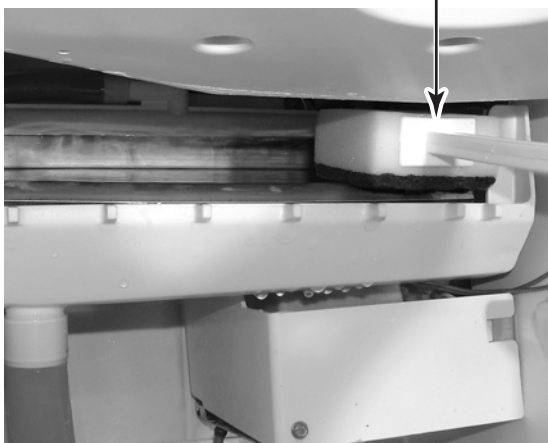

8. Pour the remaining solution from the bottle into the water reservoir. Using the empty bottle, fill the reservoir with clean water to within 1/4" of the top of the overflow port.

Add Remaining Cleaner



9. Push the Clean keypad. The Clean light will turn on to show that the Clean cycle is in progress. When the light turns off (after approximately 50 minutes), the cleaning cycle is complete. During the cleaning cycle, the system both cleans and rinses itself.
10. After the cleaning cycle is complete, remove the drain cap from the water reservoir, and see if any cleaning solution is left in the water as it drains out. If the water is green in color from the cleaning solution, it will be necessary to run another cleaning cycle to flush the system. Be sure to replace the drain cap securely to prevent leaking.
11. When the flushing process is completed, press the ON keypad to resume ice production.

ADJUSTING THE ICE THICKNESS

! WARNING



Electrical Shock Hazard
Disconnect power before servicing.
Replace all parts and panels before operating.
Failure to do so can result in death or electrical shock.

Control board #6100499 with Code Date MGR/0245 (45th week, 2002), or higher, will allow ice thickness adjustments. The approximate ice thickness settings are as follows:

- Ice Thickness @ Normal = 0.32" (8.1 mm)
- Ice Thickness @ Thin = 0.28" (7.0 mm)
- Ice Thickness @ Thick = 0.39" (9.9 mm)

Ice thickness is controlled by the placement of a jumper at P4 on the control board. The jumper positions for the three ice thickness settings are shown below. NOTE: If the jumper is missing, or in any position other than those shown below, the unit will produce normal ice thickness.

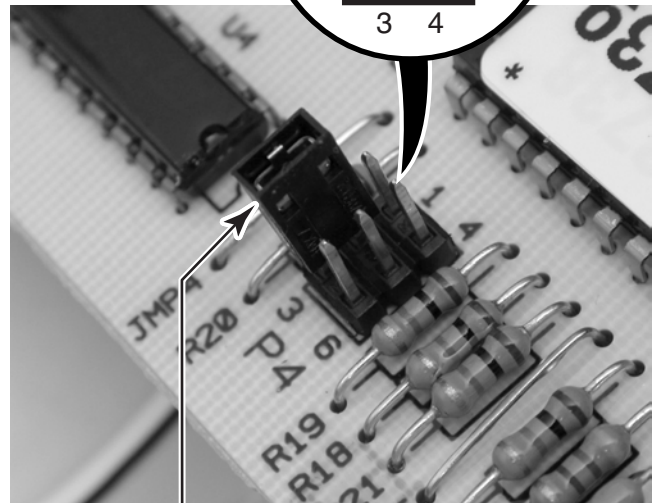
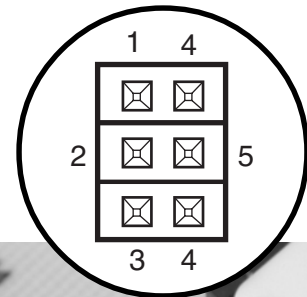
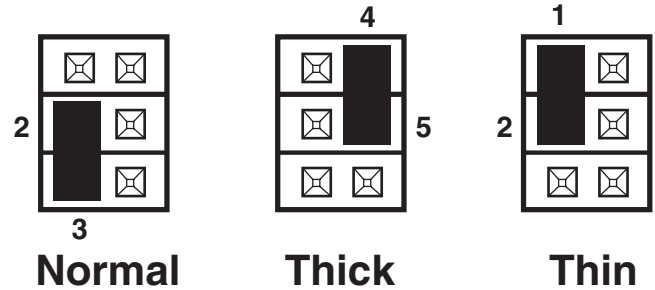

Ice Thickness Jumper

Jumper At P4 Shown In The Factory Default (Normal) Position

— NOTES —

PRODUCT SPECIFICATIONS AND WARRANTY INFORMATION SOURCES

IN THE UNITED STATES:

FOR PRODUCT SPECIFICATIONS AND WARRANTY INFORMATION CALL:

FOR WHIRLPOOL PRODUCTS: 1-800-253-1301
FOR KITCHENAID PRODUCTS: 1-800-422-1230
FOR ROPER PRODUCTS: 1-800-447-6737

FOR TECHNICAL ASSISTANCE WHILE AT THE CUSTOMER'S HOME CALL:

THE TECHNICAL ASSISTANCE LINE: 1-800-253-2870

**HAVE YOUR STORE NUMBER READY TO IDENTIFY YOU AS AN
AUTHORIZED SERVICER**

FOR LITERATURE ORDERS:

PHONE: 1-800-851-4605

IN CANADA:

FOR PRODUCT SPECIFICATIONS AND WARRANTY INFORMATION CALL:

1-800-461-5681

FOR TECHNICAL ASSISTANCE WHILE AT THE CUSTOMER'S HOME CALL:

THE TECHNICAL ASSISTANCE LINE: 1-800-488-4791

**HAVE YOUR STORE NUMBER READY TO IDENTIFY YOU AS AN
AUTHORIZED SERVICER**

KitchenAid®
FOR THE WAY IT'S MADE.®