

Commercial Automatic Washer

Metered and Nonmetered
Refer to Page 6 for Model Numbers

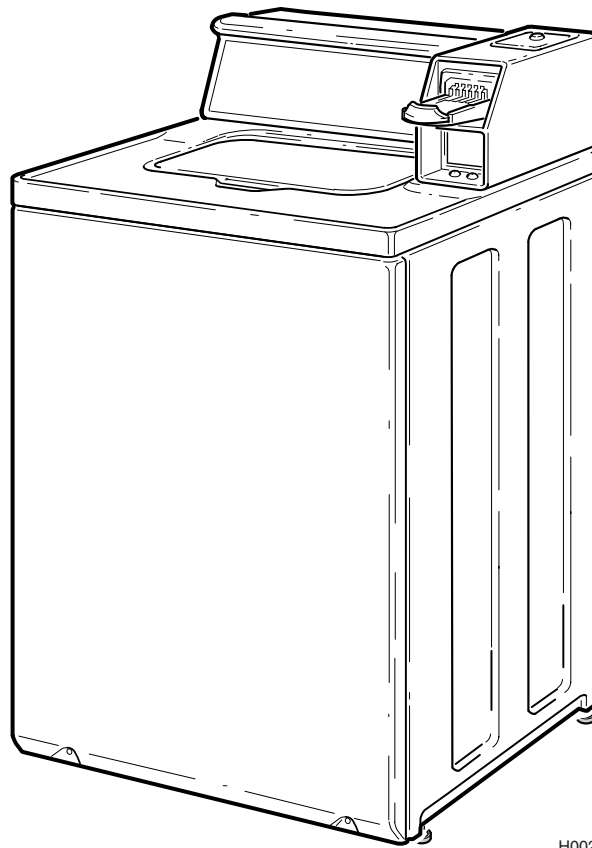

H002C

Service

Table of Contents

Section 1 – Safety Information

Locating an Authorized Servicer	4
---------------------------------------	---

Section 2 – Introduction

Customer Service	5
Nameplate Location	5
Model Identification	6
How Your Washer Works	8

Section 3 – Troubleshooting

1. No Hot Water	11
2. No Cold Water	11
3. No Warm Water	11
4. Water Fill Does Not Stop At Proper Level	12
5. Timer Does Not Advance	12
6. Motor Does Not Run	13
7. No Agitation	13
8. Constant Agitation	14
9. Washer Overheats, Cycles On Motor Thermal Protector, Switch Actuator Kicks In And Out	14
10. Slow Spin Or No Spin	15
11. Constant Spin	15
12. Washer Stops In Cycle; Quits After A Couple Loads; Is Intermittent	16
13. Washer Is Locked Up Or Binding	16
14. Outer Tub Does Not Empty	16
15. Excessive Vibration	17
16. Water Leaking From Outer Tub	17

Section 4 – Grounding

17. Wall Receptacle Polarity Check	19
18. Power Cord To Control Hood, Control Hood To The Control Panel Frame	19
19. Control Hood Wire Harness To Top Left Rear Corner Gusset Of Cabinet	20
20. Wire Harness To Motor	20

Section 5 – Service Procedures

21. Control Hood Assembly	21
22. Timer Assembly	24
23. Meter Or Timer Case Assembly	34
24. Drain Hose Elbow	35
25. Loading Door	35
26. Agitator	37
27. Agitator, Drive Bell And Seal Assembly	37
28. Front Panel	41
29. Cabinet Top Assembly	42
30. Motor And Mounting Bracket	44
31. Motor Drive Pulley	48
32. Motor Switch	48
33. Idler Lever And Pulley	49
34. Mixing Valve Assembly	50
35. Door Switch	51
36. Washtub And Balance Ring	52
37. Hub And Seal Kit Assembly	56
38. Outer Tub	60
39. Drive Pulley, Helix And Brake	62
40. Weldment And Bearing Assembly	66
41. Transmission Assembly	68
42. Upper Bearing Assembly	75
43. Friction Ring	76

Section 6 – Adjustments

44. Leveling Legs	79
45. Pressure Switch	80
46. Belt (Agitate and Spin)	80

Section 7 – Motor Test Procedure

Section 8 – Cycle Sequence Charts

Timer No. 28716 Cycle Sequence	83
Timer No. 31111P Cycle Sequence	84
Timer No. 34601P Cycle Sequence	85
Timer No. 34602 Cycle Sequence	86

Section 9 – Internal Wiring of Washer Motor Switch

(continued)

© Copyright 2001, Alliance Laundry Systems LLC

All rights reserved. No part of the contents of this book may be reproduced or transmitted in any form or by any means without the expressed written consent of the publisher.

Section 10 – Wiring Diagrams	89
Models HWT020*A, HWT020*C, HWT020*M, SWT020*A, SWT020*M, SWT021*A, SWT021*M, UWT021*A and UWT021*M.....	90
Models HWT110*A, HWT110*C, HWT110*M, SWT110*A, SWT110*M, SWT111*A and SWT111*M.....	91
Models JWT110*A and JWT110*M.....	92
Models HWT120*A, HWT120*C, HWT120*M, SWT120*A, SWT120*M, SWT121*A and SWT121*M.....	93
Models SWT210*A and SWT210*M	94
Models SWT220*A, SWT220*M, SWT221*A and SWT221*M.....	95
Models SWT320*A, SWT320*M, SWT321*A and SWT321*M.....	96
Models SWT420*A, SWT420*D, SWT420*M, SWT421*A, SWT421*D, SWT421*M, SWT520*A, SWT520*M, SWT521*A, SWT521*M, SWT620*M, SWT621*M, SWT720*M and SWT721*M.....	97
Model SWT620*A.....	98
Models HWT620*C, SWT620*C, SWT621*C, SWT620*D and SWT621*D	99
Models SWT720*A and SWT721*A	100
Models SWTA21*M, SWTB20*M, SWTB21*J, SWTB21*M, SWTC20*M, SWTC21*M, SWTF20*M, SWTF21*M, SWTH21*J, SWTH21*M and SWTJ21*M	101

Section 1

Safety Information

Throughout this manual and on machine decals, you will find precautionary statements (“CAUTION,” “WARNING,” and “DANGER”) followed by specific instructions. These precautions are intended for the personal safety of the operator, user, servicer and those maintaining the machine.

▲ DANGER

Danger indicates the presence of a hazard that **will** cause **severe** personal injury, death or substantial property damage if the danger is ignored.

▲ WARNING

Warning indicates the presence of a hazard that **can** cause **severe** personal injury, death or substantial property damage if the warning is ignored.

▲ CAUTION

Caution indicates the presence of a hazard that **will** or **can** cause **minor** personal injury or property damage if the caution is ignored.

Additional precautionary statements (“IMPORTANT” and “NOTE”) are followed by specific instructions.

IMPORTANT

The word “IMPORTANT” is used to inform the reader of specific procedures where minor machine damage will occur if the procedure is not followed.

NOTE

The word “NOTE” is used to communicate installation, operation, maintenance or servicing information that is important but not hazard related.

In the interest of safety, some general precautions relating to the operation of this machine follow.



WARNING

- **Failure to install, maintain and/or operate this product according to the manufacturer’s instructions may result in conditions which can produce serious injury, death and/or property damage.**
- **Do not repair or replace any part of the product or attempt any servicing unless specifically recommended or published in this Service Manual and that you understand and have the skills to carry out.**
- **Whenever ground wires are removed during servicing, these ground wires must be reconnected to ensure that the product is properly grounded and to reduce the risk of fire, electric shock, serious injury or death.**

W006R1



WARNING

To reduce the risk of electric shock, fire, explosion, serious injury or death:

- Disconnect electric power to the dryer(s) before servicing.
- Close gas shut-off valve to gas dryer(s) before servicing.
- Never start the dryer(s) with any guards/panels removed.
- Whenever ground wires are removed during servicing, these ground wires must be reconnected to ensure that the dryer is properly grounded.

W001R1



WARNING

Repairs that are made to your products by unqualified persons can result in hazards due to improper assembly or adjustments subjecting you, or the inexperienced person making such repairs, to the risk of serious injury, electrical shock or death.

W007



WARNING

If you or an unqualified person perform service on your product, you must assume the responsibility for any personal injury or property damage which may result. The manufacturer will not be responsible for any injury or property damage arising from improper service and/or service procedures.

W008

NOTE: The WARNINGS and IMPORTANT INSTRUCTIONS appearing in this manual are not meant to cover all possible conditions and situations that may occur. Common sense, caution and care must be exercised when installing, maintaining or operating the washer.

Always contact your dealer, distributor, service agent or the manufacturer about any problems or conditions you do not understand.

Locating an Authorized Servicer

Alliance Laundry Systems is not responsible for personal injury or property damage resulting from improper service. Review all service information before beginning repairs.

Warranty service must be performed by an authorized technician, using authorized factory parts. If service is required after the warranty expires, Alliance Laundry Systems also recommends contacting an authorized technician and using authorized factory parts.

Section 2

Introduction

Customer Service

If literature or replacement parts are required, contact the source from whom the machine was purchased or contact Alliance Laundry Systems at (920) 748-3950 for the name and address of the nearest authorized parts distributor.

For technical assistance, call (920) 748-3121.

Nameplate Location

When calling or writing about your product, be sure to mention model and serial numbers. Model and serial numbers are located on nameplate(s) as shown.

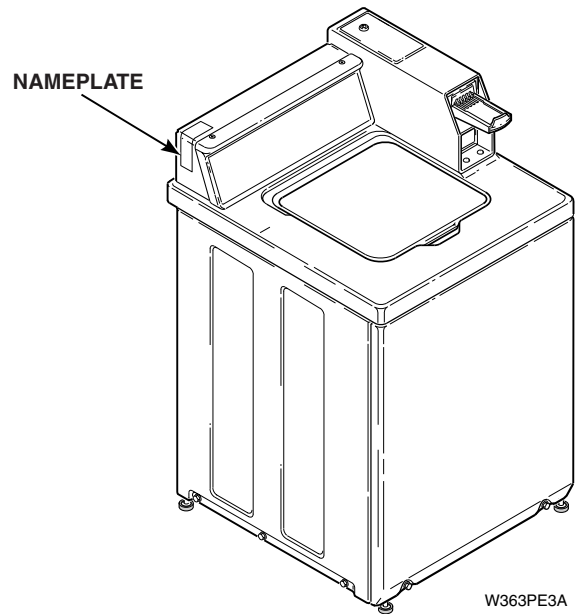

Model Identification

Information in this manual is applicable to these washers.

Washer Model	Non-metered	Metered	Electronic Display Control	Coin Slide Ready	Coin Drop Ready	Coin Drop Installed	Card Reader Ready	Card Reader Installed	Motor	Washtub
HWT020*A	X								2	P
HWT020*C	X								2	P
HWT020*M	X								2	P
HWT110*A		X		X					1	P
HWT110*C		X		X					1	P
HWT110*M		X		X					1	P
HWT120*A		X		X					2	P
HWT120*C		X		X					2	P
HWT120*M		X		X					2	P
JWT110*A		X		X					1	P
JWT110*M		X		X					1	P
SWTB20*M		X	X			X			2	P
SWTC20*M		X	X				X		2	P
SWTF20*M		X	X					X	2	P
SWT020*A	X								2	P
SWT020*M	X								2	P
SWTA21*M		X	X		X				2	S
SWTB21*M		X	X			X			2	S
SWTC21*M		X	X				X		2	S
SWTF21*M		X	X					X	2	S
SWTH21*M		X	X			X			2	S
SWTJ21*M		X	X					X	2	S
SWT021*A	X								2	S
SWT021*M	X								2	S
SWT110*A		X		X					1	P
SWT110*M		X		X					1	P
SWT111*A		X		X					1	S
SWT111*M		X		X					1	S
SWT120*A		X		X					1	P
SWT120*M		X		X					1	P
SWT121*A		X		X					2	S
SWT121*M		X		X					2	S
SWT210*A		X		X					1	P
SWT210*M		X		X					1	P
SWT220*A		X		X					2	P
SWT220*M		X		X					2	P
SWT221*A		X		X					2	S
SWT221*M		X		X					2	S

* Add Letter To Designate Color. L – Almond W – White

Key: 1 = 1 Speed Motor, 2 = 2 Speed Motor, P = Porcelain Washtub, S = Stainless Steel Washtub

Washer Model	Non-metered	Metered	Electronic Display Control	Coin Slide Ready	Coin Drop Ready	Coin Drop Installed	Card Reader Ready	Card Reader Installed	Motor	Washtub
SWT320*A		X		X					2	P
SWT320*M		X		X					2	P
SWT321*A		X		X					2	S
SWT321*M		X		X					2	S
SWT420*A		X	X		X				2	P
SWT420*D		X	X		X				2	P
SWT420*M		X	X		X				2	P
SWT421*A		X	X		X				2	S
SWT421*D		X	X		X				2	S
SWT421*M		X	X		X				2	S
SWT520*A		X	X			X			2	P
SWT520*M		X	X			X			2	P
SWT521*A		X	X			X			2	S
SWT521*M		X	X			X			2	S
SWT620*A		X	X				X		2	P
SWT620*C		X	X				X		2	P
SWT620*D		X	X				X		2	P
SWT620*M		X	X				X		2	P
SWT621*C		X	X				X		2	S
SWT621*D		X	X				X		2	S
SWT621*M		X	X				X		2	S
SWT720*A		X	X					X	2	P
SWT720*M		X	X					X	2	P
SWT721*A		X	X					X	2	S
SWT721*M		X	X					X	2	S
UWT021*A	X								2	S
UWT021*M	X								2	S

* Add Letter To Designate Color. L – Almond W – White

Key: 1 = 1 Speed Motor, 2 = 2 Speed Motor, P = Porcelain Washtub, S = Stainless Steel Washtub

How Your Washer Works

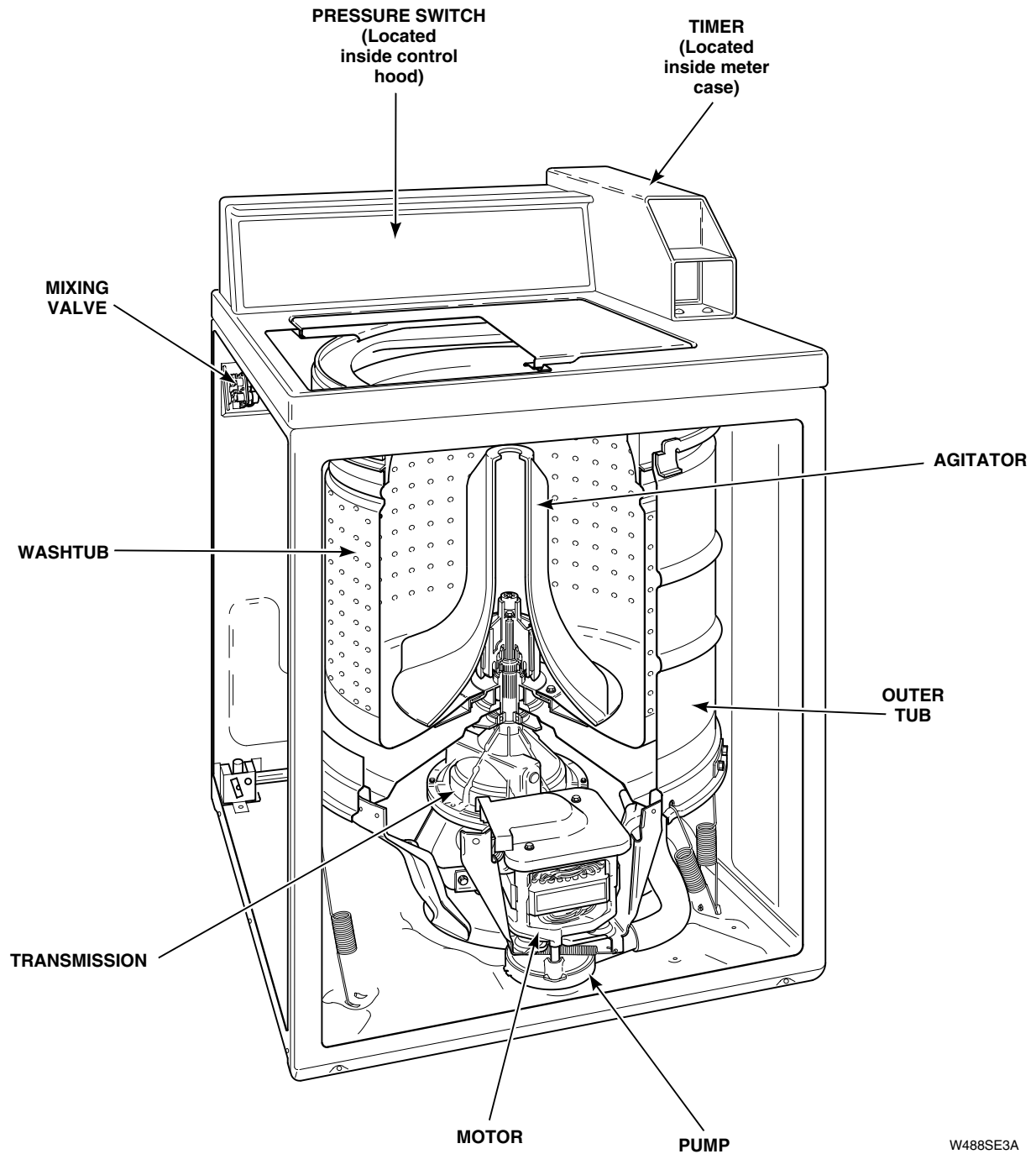

W488SE3A

The cycle begins with a wash fill. The water temperature is determined by the temperature selector. While water fills the washtub, a column of air is trapped in a pressure bulb and hose. The air pressure continues to increase as the washtub fills with water until it is great enough to activate the pressure switch. The pressure switch then causes the wash fill to stop

and wash agitation to begin. However, the loading door must be closed for the washer to agitate or spin.

The washer uses a reversing type motor, a special drive belt and an idler assembly. The idler assembly applies tension to the outside of the drive belt.

During agitation, the motor runs in the counterclockwise direction. The spring tension on the idler pulley applies the tension required to reduce the slack on the drive belt and maintain maximum belt to motor pulley contact. This eliminates belt slippage and ensures an efficient wash action, even with extra large loads.

The belt drives the transmission drive pulley in the counterclockwise direction. The pulley drives the helix which is splined to the input shaft of the transmission. This causes the input shaft to turn inside of a roller clutch which is pressed into the transmission cover. This roller clutch acts as a bearing in the counterclockwise direction allowing the transmission gears to operate. The transmission's rack and pinion gear design produces a 210 degree agitation stroke at the output shaft of the transmission which drives the agitator. The brake assembly remains locked during the agitation mode since no pressure is applied to it by the transmission drive pulley.

After the wash agitation is completed, the timer advances into the first spin. During spin, the motor reverses turning in the clockwise direction to spin the water out of the washtub. The combination of water, washtub and load weight cause the drive belt tension on the idler side of the belt to overtake the idler spring pressure allowing the belt to become slack on the opposite side. This reduces the belt to pulley contact and allows slipping between the belt and pulley.

As water is removed by the pump and the momentum of the washtub increases, the idler spring tension gradually overcomes the belt tension removing the belt slack. This eventually increases the belt to pulley contact until maximum spin speed is achieved.

The drive pulley turns clockwise riding up the ramps of the helix, exerting pressure on the brake and forcing it to release from brake pads. The helix drives the input shaft of the transmission, and when the input shaft turns in the clockwise direction the roller clutch locks onto the shaft causing the entire transmission assembly to turn. None of the gears in the transmission are operating at this time. The hub of the washtub is splined to the transmission tube and rotates with the transmission assembly. The centrifugal force created by the spinning washtub causes water to be extracted from the clothes.

Water is introduced during the first spin to "SPRAY" the garments and remove suds from them. The initial spin is followed by rinse agitation to rinse away any detergent residue. The washer fills and then agitates like the wash portion of the cycle. Following rinse agitation, a final spin extracts the rinse water from the clothes preparing them for the dryer.

Section 3

Troubleshooting



WARNING

- To reduce the risk of electric shock, fire, explosion, serious injury or death:
- Disconnect electric power to the washer before servicing.
 - Never start the washer with any guards/panels removed.
 - Whenever ground wires are removed during servicing, these ground wires must be reconnected to ensure that the washer is properly grounded.

W003

IMPORTANT: Refer to appropriate model wiring diagram for aid in testing washer components.

1. NO HOT WATER

POSSIBLE CAUSE	TO CORRECT
Hot water supply faucet is closed.	• Open faucet.
Water supply is cold.	• Check water heater.
Kinked hot water inlet hose.	• Straighten or replace hose.
Clogged mixing valve screen, or clogged screen in outer end of inlet hose nearest water supply faucet.	• Disconnect hot water inlet hose, and clean or replace screen.
Inoperative hot water mixing valve solenoid.	• Test solenoid and replace if inoperative.
Inoperative timer.	• Test timer and replace if inoperative.
Inoperative temperature switch.	• Test switch and replace if inoperative.
Inoperative pressure switch.	• Test switch and replace if inoperative.
Clogged pressure hose.	• Remove and clean or replace hose.
Broken, loose or incorrect wiring.	• Refer to appropriate wiring diagram.

2. NO COLD WATER

POSSIBLE CAUSE	TO CORRECT
Cold water supply faucet is closed.	• Open faucet.
Kinked cold water inlet hose.	• Straighten or replace hose.
Clogged mixing valve screen, or clogged screen in outer end of inlet hose nearest water supply faucet.	• Disconnect cold water inlet hose, and clean or replace screen.
Inoperative cold water mixing valve solenoid.	• Test solenoid and replace if inoperative.
Inoperative timer.	• Test timer and replace if inoperative.
Inoperative temperature switch.	• Test switch and replace if inoperative.
Inoperative pressure switch.	• Test switch and replace if inoperative.
Clogged pressure hose.	• Remove and clean or replace hose.
Broken, loose or incorrect wiring.	• Refer to appropriate wiring diagram.

3. NO WARM WATER

POSSIBLE CAUSE	TO CORRECT
No hot water.	• Refer to <i>Paragraph 1</i> .
No cold water.	• Refer to <i>Paragraph 2</i> .



WARNING

To reduce the risk of electric shock, fire, explosion, serious injury or death:

- **Disconnect electric power to the washer before servicing.**
- **Never start the washer with any guards/panels removed.**
- **Whenever ground wires are removed during servicing, these ground wires must be reconnected to ensure that the washer is properly grounded.**

W003

4. WATER FILL DOES NOT STOP AT PROPER LEVEL

POSSIBLE CAUSE	TO CORRECT
Inoperative pressure switch.	<ul style="list-style-type: none"> • Test switch and replace if inoperative.
Air leak in pressure hose.	<ul style="list-style-type: none"> • Replace hose.
Sediment on or under mixing valve diaphragm, defective diaphragm, or armature binding in armature guide.	<ul style="list-style-type: none"> • Disassemble and clean mixing valve.
Broken, weak or missing mixing valve armature spring.	<ul style="list-style-type: none"> • Disassemble valve and replace spring.
A siphoning action started in washer will cause water to be siphoned from washer during cycle due to end of drain hose being lower than cabinet top of washer. Drain hose fits tight in standpipe or drain.	<ul style="list-style-type: none"> • Install No. 562P3 Siphon Break Kit. Provide an air gap around drain hose and drain receptacle.
Water in pressure hose.	<ul style="list-style-type: none"> • Blow air through hose to remove water.
Broken, loose, shorted or incorrect wiring.	<ul style="list-style-type: none"> • Refer to appropriate wiring diagram.

5. TIMER DOES NOT ADVANCE

POSSIBLE CAUSE	TO CORRECT
Timer is designed to pause during fill periods.	<ul style="list-style-type: none"> • Allow completion of fill period.
Inoperative timer.	<ul style="list-style-type: none"> • Test timer, and replace if inoperative.
Loading door is open.	<ul style="list-style-type: none"> • Close loading door. Loading door MUST be closed any time the washer is set to fill, agitate or spin.
Washer will not fill.	<ul style="list-style-type: none"> • Timer pauses until pressure switch is satisfied.
Timer motor lead wire off timer terminal.	<ul style="list-style-type: none"> • Refer to appropriate wiring diagram and reattach wire.
Broken, loose or incorrect wiring.	<ul style="list-style-type: none"> • Refer to appropriate wiring diagram.
Timer is designed to pause when going from agitate to spin.	<ul style="list-style-type: none"> • Allow time for timer to go through that step. See diagram for information on time required.
Timer is designed to stop if washer drive motor has been over loaded and motor thermal overload has tripped.	<ul style="list-style-type: none"> • Motor thermal protector reset time may vary depending upon the reason for the washer overload, however, it should reset within 15 minutes. Check to ensure that washer was not overloaded with clothes.
Is circuit breaker to washer tripped, disconnecting power to washer.	<ul style="list-style-type: none"> • Reset circuit breaker.
Washer will not fill.	<ul style="list-style-type: none"> • Timer is designed to pause when going from spin into rinse to allow the washtub to stop spinning before filling, make sure that timer has advanced into fill portion of rinse cycle.



WARNING

To reduce the risk of electric shock, fire, explosion, serious injury or death:

- Disconnect electric power to the washer before servicing.
- Never start the washer with any guards/panels removed.
- Whenever ground wires are removed during servicing, these ground wires must be reconnected to ensure that the washer is properly grounded.

W003

6. MOTOR DOES NOT RUN

POSSIBLE CAUSE	TO CORRECT
Electrical power off, fuse blown or power cord not plugged in.	<ul style="list-style-type: none"> • Check laundry room for blown or loose fuse(s) or open circuit breakers. (Washer itself does not have an electrical fuse).
Loading door not closed or inoperative switch.	<ul style="list-style-type: none"> • Close door or test switch and replace if inoperative.
Timer improperly set.	<ul style="list-style-type: none"> • Reset timer, or try another cycle.
Inoperative timer.	<ul style="list-style-type: none"> • Test timer and replace if inoperative.
Motor starting functions inoperative. No start; or motor hums only.	<ul style="list-style-type: none"> • Refer to <i>Section 7</i> to check start switch and start windings.
Motor is dead, won't run.	<ul style="list-style-type: none"> • Refer to <i>Section 7</i> to check switch and windings.
Motor overload protector has cycled.	<ul style="list-style-type: none"> • Wait two or three minutes for overload protector to reset. If protector cycles repeatedly, refer to <i>Paragraph 9</i>.
Bind in upper or lower motor bearing.	<ul style="list-style-type: none"> • Remove belt and determine if motor shaft will spin. Replace motor if shaft is locked up.
Broken, loose or incorrect wiring.	<ul style="list-style-type: none"> • Refer to appropriate wiring diagram.
Power cord is miswired.	<ul style="list-style-type: none"> • Refer to appropriate wiring diagram for correct wiring.

7. NO AGITATION

POSSIBLE CAUSE	TO CORRECT
Inoperative timer.	<ul style="list-style-type: none"> • Test timer and replace if inoperative.
Inoperative action switch.	<ul style="list-style-type: none"> • Test switch and replace if inoperative.
Motor will not run.	<ul style="list-style-type: none"> • Refer to <i>Section 7</i> to check switch and windings.
Inoperative pressure switch.	<ul style="list-style-type: none"> • Test switch and replace if inoperative.
Broken, loose or incorrect wiring.	<ul style="list-style-type: none"> • Refer to appropriate wiring diagram.
Broken drive belt.	<ul style="list-style-type: none"> • Replace belt.
Inoperative transmission assembly.	<ul style="list-style-type: none"> • Replace transmission assembly.
Sheared motor pulley roll pin. (Through Serial No. 001113645)	<ul style="list-style-type: none"> • Remove drive motor and replace roll pin and any other damaged parts.
Drive motor overload protector has cycled.	<ul style="list-style-type: none"> • Refer to <i>Paragraph 9</i>.
Bind in pump.	<ul style="list-style-type: none"> • Replace pump.
Loading door is open or door switch is inoperative.	<ul style="list-style-type: none"> • Close door or test switch and replace if inoperative.



WARNING

To reduce the risk of electric shock, fire, explosion, serious injury or death:

- Disconnect electric power to the washer before servicing.
- Never start the washer with any guards/panels removed.
- Whenever ground wires are removed during servicing, these ground wires must be reconnected to ensure that the washer is properly grounded.

W003

8. CONSTANT AGITATION

POSSIBLE CAUSE	TO CORRECT
Inoperative timer.	Test timer and replace if inoperative.
Shorted or incorrect wiring.	Refer to appropriate wiring diagram.
Inoperative transmission assembly.	Repair or replace transmission assembly.

9. WASHER OVERHEATS, CYCLES ON MOTOR THERMAL PROTECTOR, SWITCH ACTUATOR KICKS IN AND OUT

POSSIBLE CAUSE	TO CORRECT
Belt is tacky and does not allow proper slip.	Check belt and replace if defective.
Belt tension is too great and does not allow proper slip.	Make sure idler spring is properly connected.
Inoperative timer.	Test timer and replace if inoperative.
Motor switch functions inoperative.	Refer to <i>Section 7</i> to check switch functions.
Bind in water pump.	Replace pump.
Brake pads or brake assembly binding.	Free binding pads, or replace pads and brake assembly.
Bearings, transmission or motor has locked up and will not turn.	Check that all these components are able to move freely. Correct binding component.
Incorrect voltage.	Contact local utility company, or have a qualified electrician check power supply.



WARNING

To reduce the risk of electric shock, fire, explosion, serious injury or death:

- Disconnect electric power to the washer before servicing.
- Never start the washer with any guards/panels removed.
- Whenever ground wires are removed during servicing, these ground wires must be reconnected to ensure that the washer is properly grounded.

W003

10. SLOW SPIN OR NO SPIN

POSSIBLE CAUSE	TO CORRECT
Inoperative timer.	• Test timer and replace if inoperative.
Loading door is open or door safety switch is inoperative.	• Close loading door, or test switch and replace if inoperative.
Bind in water pump.	• Replace pump.
Broken or worn drive belt.	• Replace belt.
Motor will not run.	• Refer to “Motor Test” <i>Section 7</i> to check switch and windings.
Sheared motor pulley roll pin. (Through Serial No. 001113645)	• Remove drive motor and appropriately replace roll pin and any other damaged parts.
Motor overload protector has cycled.	• Wait two or three minutes for overload protector to reset. If protector cycles repeatedly, refer to <i>Paragraph 9</i> .
No clearance between brake pads and discs.	• Replace pads and brake assembly.
Broken, loose or incorrect wiring.	• Refer to appropriate wiring diagram.
Inoperative transmission assembly.	• Repair or replace the transmission assembly.

11. CONSTANT SPIN

POSSIBLE CAUSE	TO CORRECT
Inoperative timer.	Test timer and replace if inoperative.
Washtub does not stop spinning within seven seconds after loading door is opened.	Replace brake pads and brake assembly.
Excessive wear on brake pads, or missing brake pads.	Replace brake pads and brake assembly.
Shorted or incorrect wiring.	Refer to appropriate wiring diagram.



WARNING

To reduce the risk of electric shock, fire, explosion, serious injury or death:

- Disconnect electric power to the washer before servicing.
- Never start the washer with any guards/panels removed.
- Whenever ground wires are removed during servicing, these ground wires must be reconnected to ensure that the washer is properly grounded.

W003

12. WASHER STOPS IN CYCLE; QUILTS AFTER A COUPLE LOADS; IS INTERMITTENT

POSSIBLE CAUSE	TO CORRECT
Belt is tacky and does not allow proper slip.	<ul style="list-style-type: none"> • Check belt and replace if defective.
Belt tension is too great and does not allow proper slip.	<ul style="list-style-type: none"> • Make sure idler spring is properly connected.
Inoperative timer.	<ul style="list-style-type: none"> • Test timer and replace if inoperative.
Broken, loose or incorrect wiring.	<ul style="list-style-type: none"> • Refer to appropriate wiring diagram.
Motor overload protector has cycled.	<ul style="list-style-type: none"> • Wait two or three minutes for overload protector to reset. If protector cycles repeatedly, refer to <i>Paragraph 9</i>.
Motor switch functions inoperative.	<ul style="list-style-type: none"> • Refer to <i>Section 7</i> to check switch functions.
Brake, transmission or motor has locked up and will not turn.	<ul style="list-style-type: none"> • Check that all these components are able to move freely.

13. WASHER IS LOCKED UP OR BINDING

POSSIBLE CAUSE	TO CORRECT
Excessive belt tension.	<ul style="list-style-type: none"> • Replace belt and/or idler spring.
Bind in upper or lower bearing.	<ul style="list-style-type: none"> • Replace bearing.
Bind in water pump.	<ul style="list-style-type: none"> • Replace pump.
Bind in transmission.	<ul style="list-style-type: none"> • Repair or replace transmission.
Brake pads binding.	<ul style="list-style-type: none"> • Free binding pads, or replace pads.
Incorrect voltage.	<ul style="list-style-type: none"> • Contact local utility company, or have a qualified electrician check power supply.

14. OUTER TUB DOES NOT EMPTY

POSSIBLE CAUSE	TO CORRECT
Kinked drain hose.	<ul style="list-style-type: none"> • Straighten hose.
Drain hose out of hose retainer clip in back of cabinet.	<ul style="list-style-type: none"> • Remove washer front panel and install drain hose into hose retainer clip in back of cabinet.
Inoperative water pump.	<ul style="list-style-type: none"> • Replace pump.
Obstruction in outer tub outlet hose.	<ul style="list-style-type: none"> • Remove obstruction.



WARNING

To reduce the risk of electric shock, fire, explosion, serious injury or death:

- Disconnect electric power to the washer before servicing.
- Never start the washer with any guards/panels removed.
- Whenever ground wires are removed during servicing, these ground wires must be reconnected to ensure that the washer is properly grounded.

W003

15. EXCESSIVE VIBRATION

POSSIBLE CAUSE	TO CORRECT
Unbalanced load in tub.	• Stop washer, redistribute load, then restart washer.
Broken, or disconnected module spring(s).	• Connect or replace module spring(s).
Washer is not properly leveled.	• Adjust leveling legs.
Washer is installed on weak, “spongy”, carpeted or built-up floor.	• Relocate washer, or support floor to eliminate weak or “spongy” condition.
Incorrect or loose cabinet screws.	• Replace with correct screws or tighten.
Base damaged (washer was dropped).	• Replace base assembly.
Broken friction ring.	• Replace friction ring.

16. WATER LEAKING FROM OUTER TUB

POSSIBLE CAUSE	TO CORRECT
Leaking water seal in outer tub.	• Replace hub and seal kit assembly, <i>Paragraph 37</i> .
Hole in outer tub.	• Replace outer tub.
Pressure hose or accumulator leaking.	• Replace pressure hose and/or accumulator.
Outer tub cover gasket leaking.	• Replace gasket.
Obstruction in drain causing water to come over top of outer tub cover.	• Remove obstruction.
Tub-to-pump hose leaking at clamp.	• Tighten clamp.

Section 4 Grounding



WARNING

To reduce the risk of electric shock, fire, explosion, serious injury or death:

- Disconnect electric power to the washer before servicing.
- Never start the washer with any guards/panels removed.
- Whenever ground wires are removed during servicing, these ground wires must be reconnected to ensure that the washer is properly grounded.

W003

17. WALL RECEPTACLE POLARITY CHECK

Refer to *Figure 1*

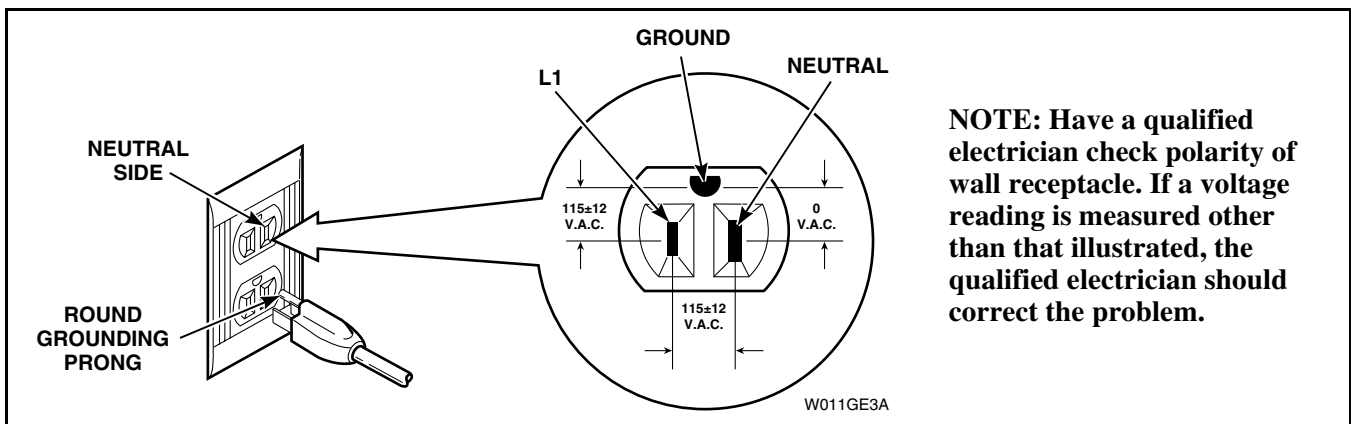

Figure 1

18. POWER CORD TO CONTROL HOOD, CONTROL HOOD TO THE CONTROL PANEL FRAME

Refer to *Figure 2*

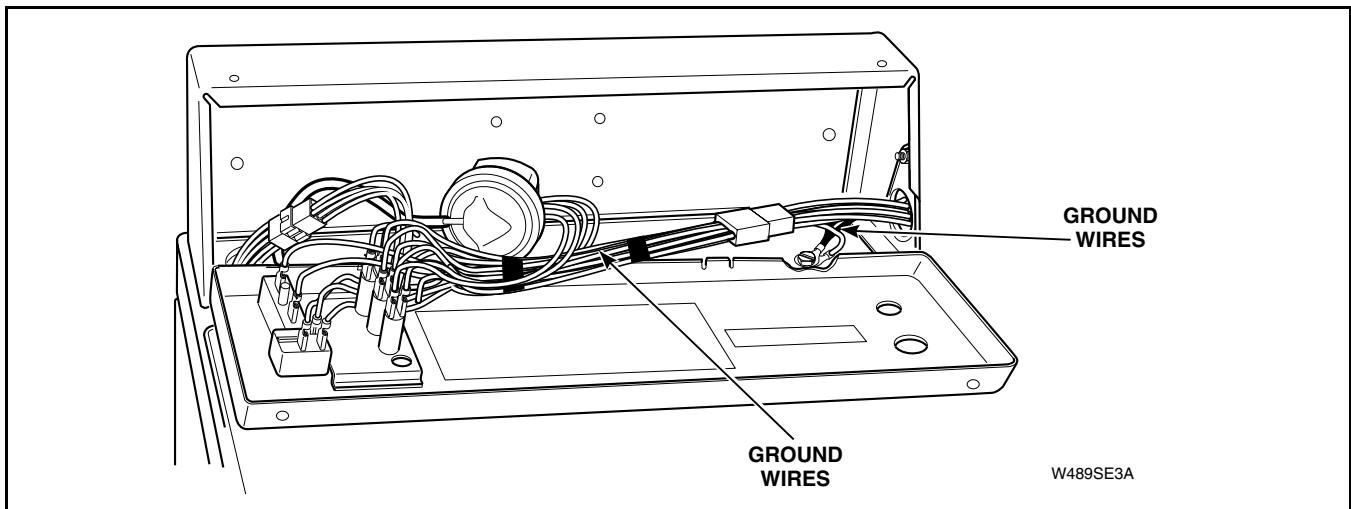

Figure 2



WARNING

To reduce the risk of electric shock, fire, explosion, serious injury or death:

- Disconnect electric power to the washer before servicing.
- Never start the washer with any guards/panels removed.
- Whenever ground wires are removed during servicing, these ground wires must be reconnected to ensure that the washer is properly grounded.

W003

19. CONTROL HOOD WIRE HARNESS TO TOP LEFT REAR CORNER GUSSET OF CABINET

Refer to *Figure 3*

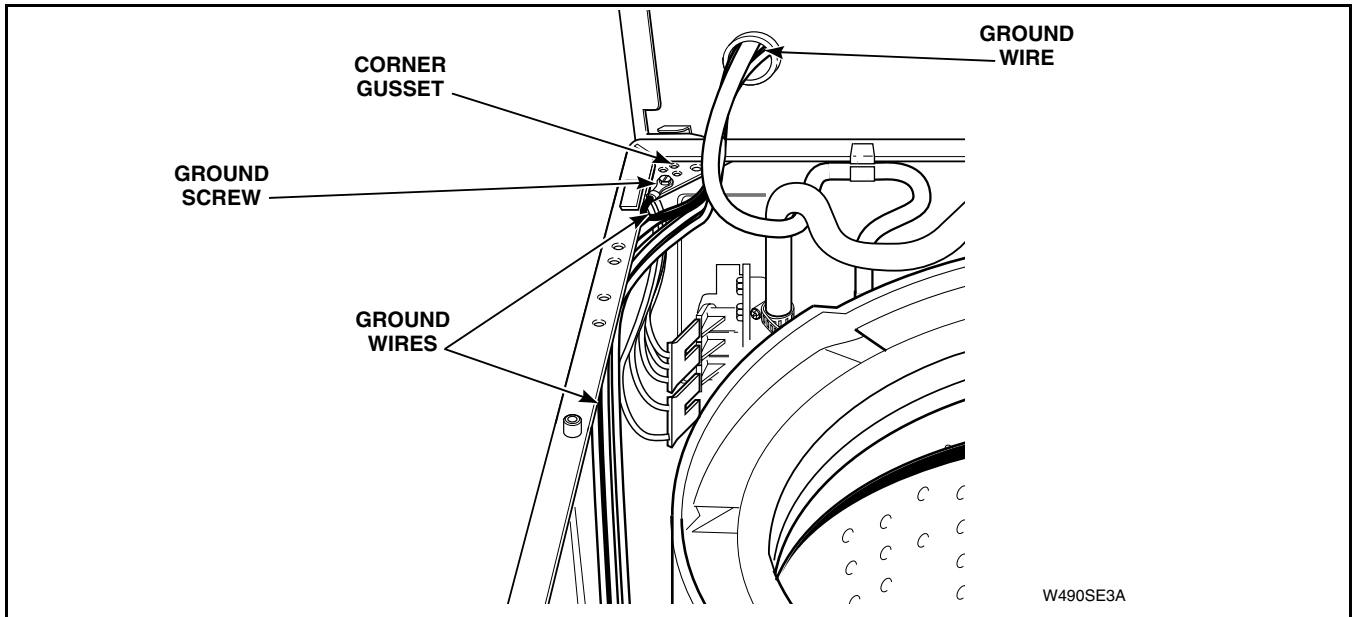

Figure 3

20. WIRE HARNESS TO MOTOR

Refer to *Figure 4*

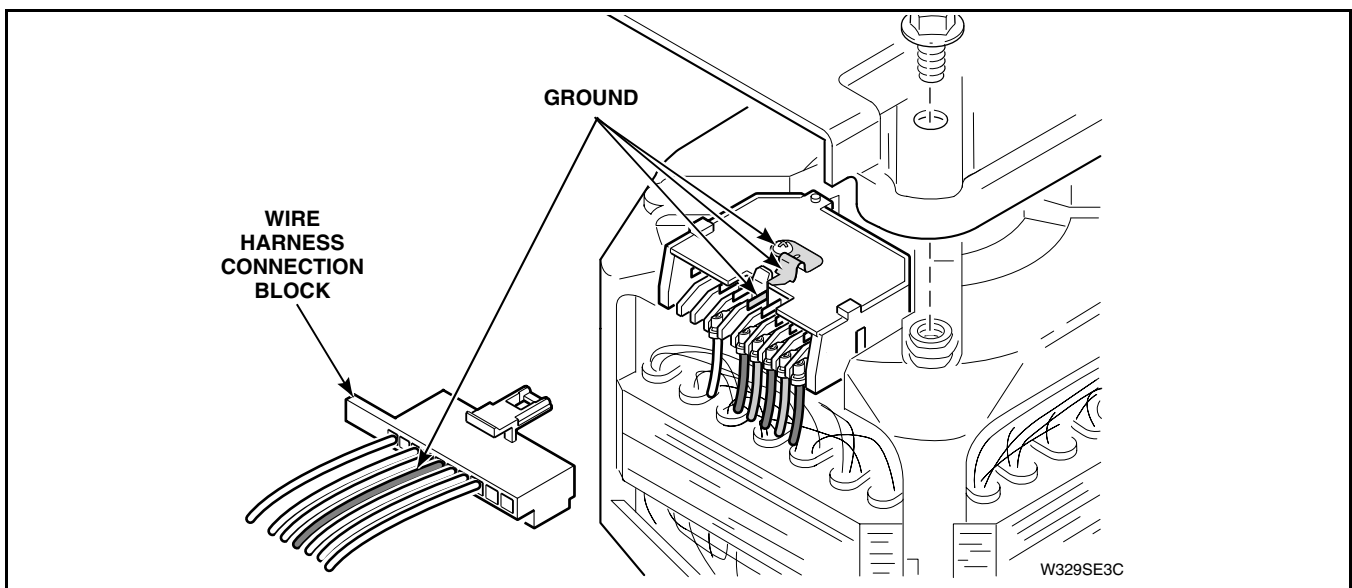

Figure 4

Section 5

Service Procedures



WARNING

To reduce the risk of electric shock, fire, explosion, serious injury or death:

- Disconnect electric power to the washer before servicing.
- Never start the washer with any guards/panels removed.
- Whenever ground wires are removed during servicing, these ground wires must be reconnected to ensure that the washer is properly grounded.

W003

IMPORTANT: When reference is made to directions (right or left) in this manual, it is from operator's position facing front of washer.

21. CONTROL HOOD ASSEMBLY

a. CONTROL PANEL:

- (1) Remove two control panel attaching screws. Refer to *Figure 5*. Lay assembly forward on a protective pad on cabinet top.
- (2) Unplug wire harness quick disconnect blocks, two ground wires and leads from pressure switch and loading door switch. Refer to *Figure 6*.

NOTE: Refer to appropriate wiring diagram when reconnecting wire harnesses, ground and switch leads.

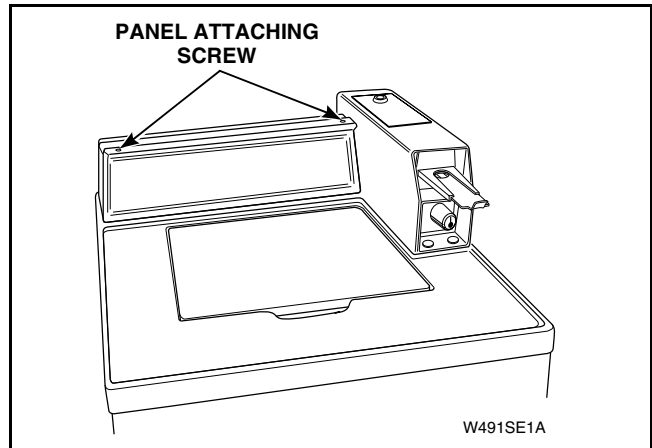

Figure 5

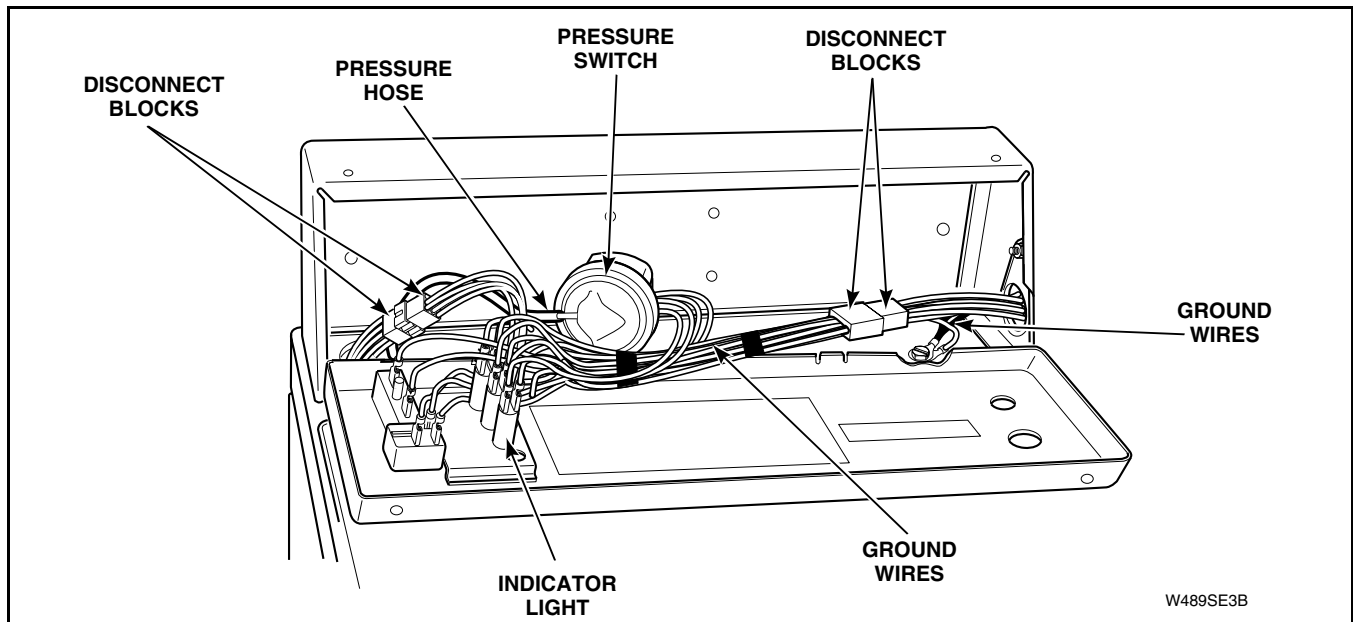

Figure 6



WARNING

To reduce the risk of electric shock, fire, explosion, serious injury or death:

- Disconnect electric power to the washer before servicing.
- Never start the washer with any guards/panels removed.
- Whenever ground wires are removed during servicing, these ground wires must be reconnected to ensure that the washer is properly grounded.

W003

b. CYCLE SELECTOR OR WASH TEMPERATURE SWITCH:

- (1) Remove two control panel attaching screws. Refer to *Figure 5*. Lay assembly forward on protective pad on cabinet top.
- (2) Loosen setscrew holding switch knob to switch shaft. Refer to *Figure 7*.
- (3) Remove knurled nut holding switch to control panel. Refer to *Figure 7*.

NOTE: Lockwasher must be between switch and control panel when installing switch. Refer to *Figure 7*.

- (4) Disconnect wires from switch.

NOTE: Refer to appropriate wiring diagram when rewiring switch.

c. INDICATOR LIGHTS

(In Use, Rinse or Spin. Refer to *Figure 6*):

- (1) Remove two control panel attaching screws. Refer to *Figure 5*. Lay assembly forward on protective pad on cabinet top.
- (2) Disconnect wires from light.

NOTE: Refer to wiring diagram when rewiring light.

- (3) Squeeze locking tabs together and pull light out rear of control panel.

d. PRESSURE SWITCH

- (1) Remove two control panel attaching screws. Refer to *Figure 5*. Lay assembly forward on protective pad on cabinet top.
- (2) Remove two screws holding switch to cabinet top. Refer to *Figure 6*.
- (3) Pull switch out of control hood far enough to disconnect pressure hose and wires from switch.

NOTE: Refer to appropriate wiring diagram when rewiring pressure switch.

IMPORTANT: When installing pressure switch, blow air into hose before connecting hose to switch to remove any moisture that may have accumulated in hose.

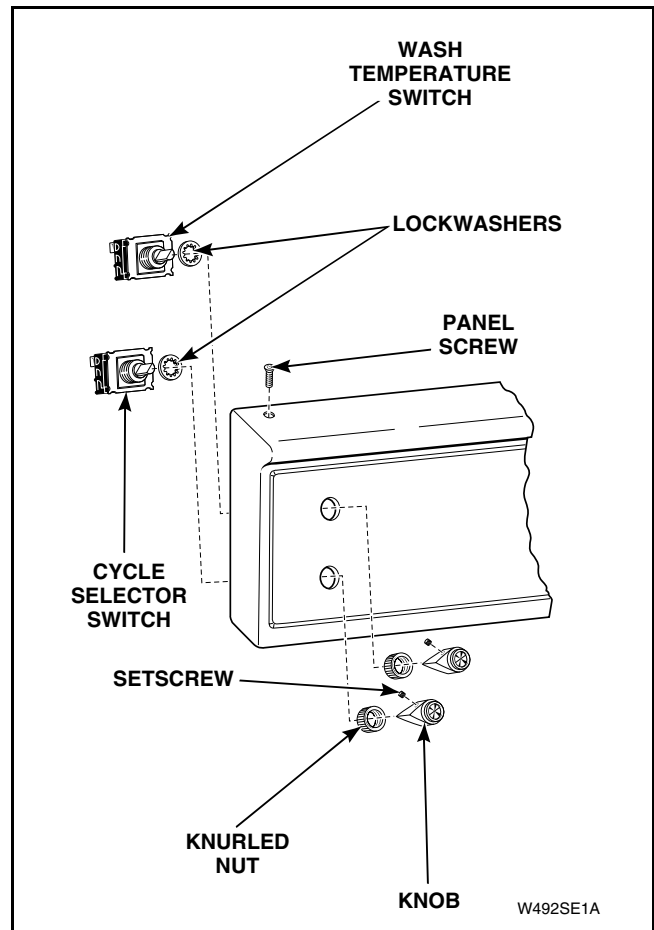

Figure 7

W492SE1A



WARNING

To reduce the risk of electric shock, fire, explosion, serious injury or death:

- Disconnect electric power to the washer before servicing.
- Never start the washer with any guards/panels removed.
- Whenever ground wires are removed during servicing, these ground wires must be reconnected to ensure that the washer is properly grounded.

W003

e. ELECTRONIC CONTROL

IMPORTANT: Due to the sensitivity of the electronic control, careful handling is required. As a precautionary measure, we recommend using a ground wrist strap when handling the electronic control. Wrist strap, cord and alligator clip are designed to carry away any electrostatic charge from your body and to direct charge to an available ground. By using this static protection device, potential electrostatic discharge problems associated with handling of electronic control will be minimized. Always handle electronic control by its metal edges. If a wrist strap is not available, touch washer while it is plugged in before handling control to dissipate any charge.

NOTE: New control is supplied in a special anti-static wrapping, and protected by anti-static foam. While holding control by its metal edges, remove control from foam and wrapping.

- (1) Remove two control panel attaching screws. Refer to *Figure 5*. Lay control panel assembly face down on protective padding.
- (2) Press in on locking tabs and unplug harness disconnect blocks from backside of

electronic control assembly. Refer to *Figure 8*.

NOTE: DO NOT pull on wires. Instead, hold board near appropriate disconnect block and unplug by pulling on disconnect block.

- (3) Remove four screws holding electronic control assembly to backside of control panel. Refer to *Figure 8*.
- (4) Place the old control in the anti-static wrapping that the new control was supplied in.
- (5) While holding new control by its metal edges, carefully peel off protective plastic coating from front side of control. Then place control in opening of control panel and fasten control down with four screws.
- (6) Follow wiring diagram and reconnect wires to new control.

IMPORTANT: It is important to take care when handling the original control. It must be carefully placed in the anti-static wrapping and anti-static foam which was removed from new control. If control is not wrapped properly, warranty credit will not be issued.

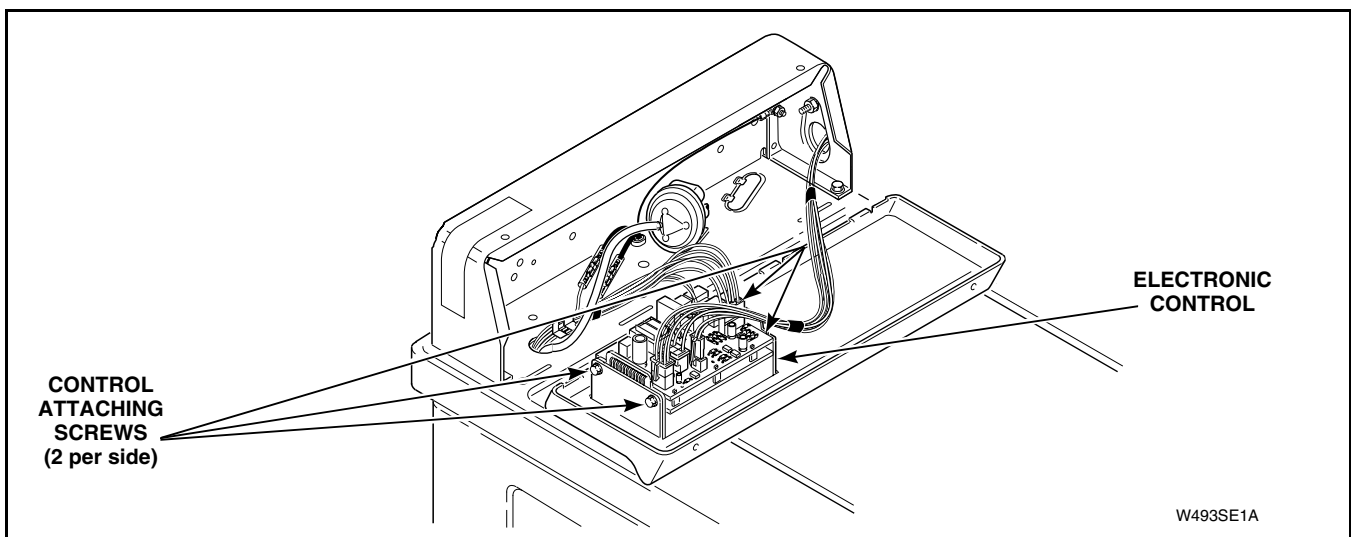

Figure 8

W493SE1A



WARNING

To reduce the risk of electric shock, fire, explosion, serious injury or death:

- Disconnect electric power to the washer before servicing.
- Never start the washer with any guards/panels removed.
- Whenever ground wires are removed during servicing, these ground wires must be reconnected to ensure that the washer is properly grounded.

W003

f. CONTROL PANEL OVERLAY

(Removal):

- (1) Remove control panel attaching screws. Refer to *Figure 5*. Lay assembly forward on protective pad on cabinet top.
- (2) Loosen setscrews holding switch knobs to switch shafts. Refer to *Figure 7*.
- (3) Remove knurled nuts holding switches to control panel. Refer to *Figure 7*.

NOTE: Lockwashers must be between switches and control panel when installing switches. Refer to *Figure 7*.

- (4) Disconnect wires from switches and indicator lights.

NOTE: Refer to appropriate wiring diagram when rewiring switches and indicator lights.

- (5) Remove control panel overlay by peeling it from control panel frame.

NOTE: Control panel overlay has an adhesive backing.

g. CONTROL PANEL OVERLAY

(Installation):

NOTE: Before removing protective backing from new overlay, check fit of overlay to control panel frame. Switch holes are the locating guides.

- (1) Once panel overlay is fitted to the front of control panel frame, carefully peel protective backing from the left end of panel overlay and press into place.
- (2) Remove rest of protective backing from panel overlay and firmly press overlay into place on control panel frame.

22. TIMER ASSEMBLY

a. TIMER REMOVAL (Metered Models):

NOTE: DO NOT attempt to repair timer.

- (1) Unlock and remove meter case service door.

- (2) Remove timer bracket cap screw. Refer to *Figure 9*.
- (3) Slide timer and bracket toward rear of meter case to disengage bracket from shoulder screw. Lift timer and bracket out of meter case through service door opening as far as wires will permit.

NOTE: If only replacing clutch, proceed to step 7.

- (4) Disengage wire harness terminal block plug from timer by pressing in movable locking tabs (located on each side of terminal block plug). Refer to *Figure 10*. Then pull terminal block plug away from timer.
- (5) Disconnect ground wire from terminal on timer. Refer to *Figure 10*.

IMPORTANT: To avoid an open circuit, DO NOT pull on terminal block wires when removing block from timer as this could damage wires or terminal crimpings. Before attaching wire harness terminal blocks to timer, be sure all male terminals on timer are straight and are capable of accepting terminals from wire harness terminal blocks.

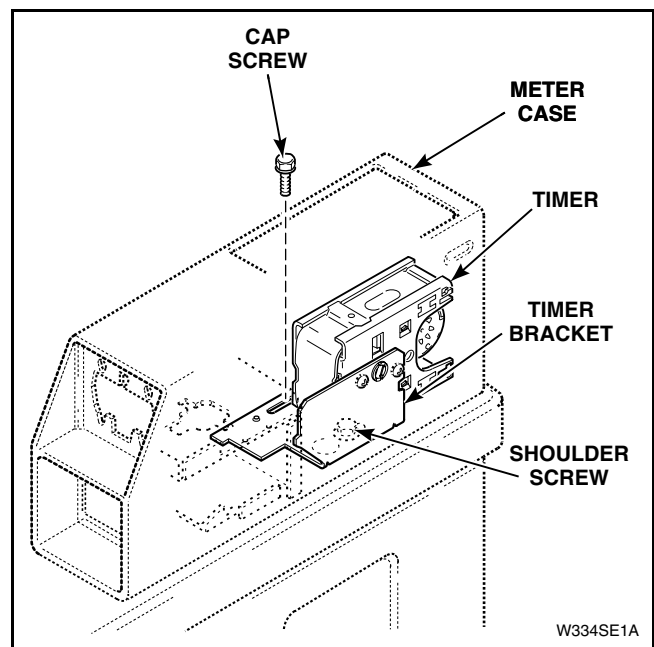

W334SE1A

Figure 9



WARNING

To reduce the risk of electric shock, fire, explosion, serious injury or death:

- Disconnect electric power to the washer before servicing.
- Never start the washer with any guards/panels removed.
- Whenever ground wires are removed during servicing, these ground wires must be reconnected to ensure that the washer is properly grounded.

W003

IMPORTANT: Be careful not to dislodge or damage two timer motor lead wires while handling timer.

NOTE: To avoid timer damage, do not allow timer to be struck on corners, edges of frame or on timer shaft.

- (6) Remove two screws holding timer to timer bracket. Refer to *Figure 10*.
- (7) Loosen setscrew holding clutch to timer shaft. Refer to *Figure 11*.

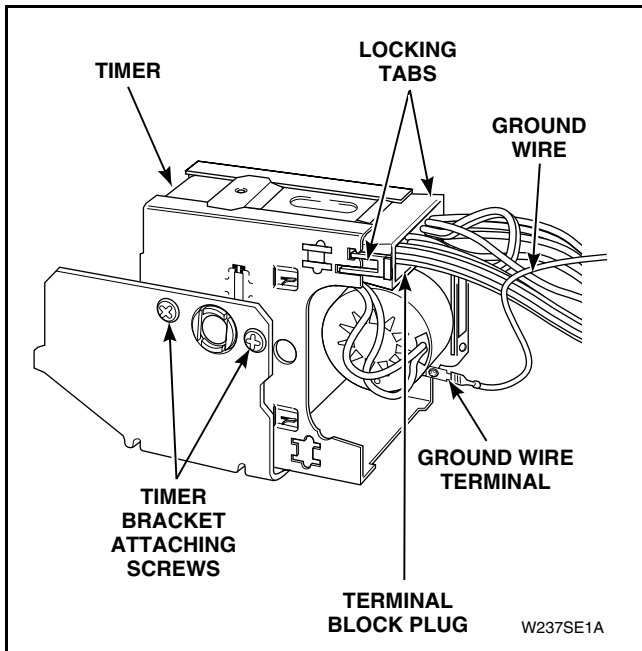

Figure 10

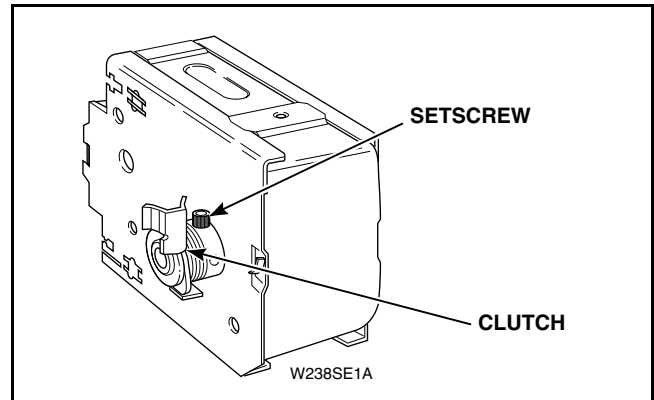

Figure 11



WARNING

To reduce the risk of electric shock, fire, explosion, serious injury or death:

- Disconnect electric power to the washer before servicing.
- Never start the washer with any guards/panels removed.
- Whenever ground wires are removed during servicing, these ground wires must be reconnected to ensure that the washer is properly grounded.

W003

b. TIMER INSTALLATION (Metered Models):

- (1) Place clutch on timer shaft and tighten setscrew. Refer to *Figure 11*.

NOTE: When installing clutch, make sure clutch moves freely after setscrew is tightened.

- (2) Attach timer to timer bracket using two screws. Refer to *Figure 10*.
- (3) Reconnect wire harness terminal block plug and ground wire to timer.
- (4) Carefully place timer and timer bracket down inside meter case so keyhole slot in bracket fits over the head of shoulder screw. Refer to *Figure 9*.
- (5) After positioning timer bracket over shoulder screw, slide timer and bracket forward until bottom front of bracket contacts rear of coin vault in meter case. Refer to *Figure 9*.
- (6) While holding timer bracket up against rear of coin vault, install cap screw and tighten firmly. Refer to *Figure 9*.
- (7) Make sure wire harness is routed along bottom of meter case so it will not interfere with any moving parts in meter case.

c. TIMER REMOVAL (Nonmetered Models):

- (1) Loosen two setscrews holding timer knob to timer shaft. Refer to *Figure 12*.
- (2) Remove four screws and lockwashers holding timer and plate to timer case. Refer to *Figure 12*.

NOTE: When reinstalling timer and plate, lockwashers must be between head of screws and timer plate.

- (3) Pull timer and plate out of timer case as far as wires will permit.

NOTE: Disconnect ground wire from ground terminal on timer.

- (4) Pull wire harness and blocks through into timer case; then disconnect timer harness from control hood harness at quick disconnect block.
- (5) Remove two screws holding timer to timer plate. Refer to *Figure 12*.
- (6) Disconnect wires from timer.

NOTE: Refer to appropriate wiring diagram when rewiring timer.

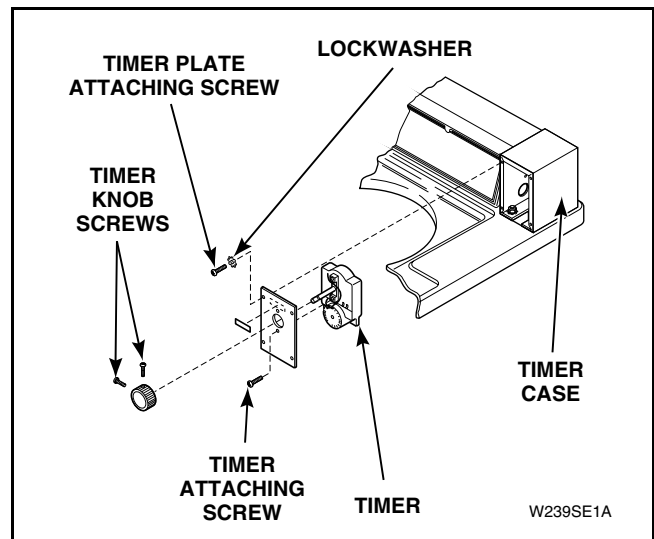

Figure 12



WARNING

To reduce the risk of electric shock, fire, explosion, serious injury or death:

- Disconnect electric power to the washer before servicing.
- Never start the washer with any guards/panels removed.
- Whenever ground wires are removed during servicing, these ground wires must be reconnected to ensure that the washer is properly grounded.

W003

d. SINGLE COIN DROP REMOVAL

- (1) Unlock and open service door.

NOTE: If screw type lock is used, the retainer bracket must be removed from inside meter case.

- (2) Disconnect wire harness from coin drawer switch and disconnect coin drop at disconnect plugs.
- (3) Press in on locking tabs of service door switch and remove switch from bracket on meter case, as shown in *Figure 13*.

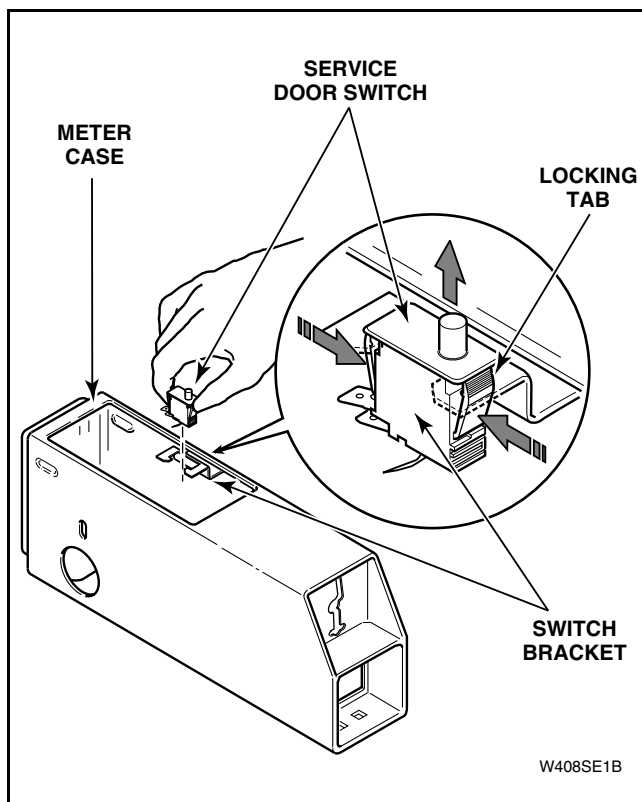

Figure 13

- (4) Use a 7/16 inch socket with No. 310P4 1/4 inch Ratchet Extension Tool and remove two locknuts holding coin drop to front of meter case. Refer to *Figure 14*.
- (5) Lift back end of coin drop and pull straight back until bottom edge of drop's front face plate falls behind the coin drawer housing.
- (6) Carefully lift complete coin drop straight up and out of meter case.

e. SINGLE COIN DROP INSTALLATION

- (1) Reverse removal procedures for installation.

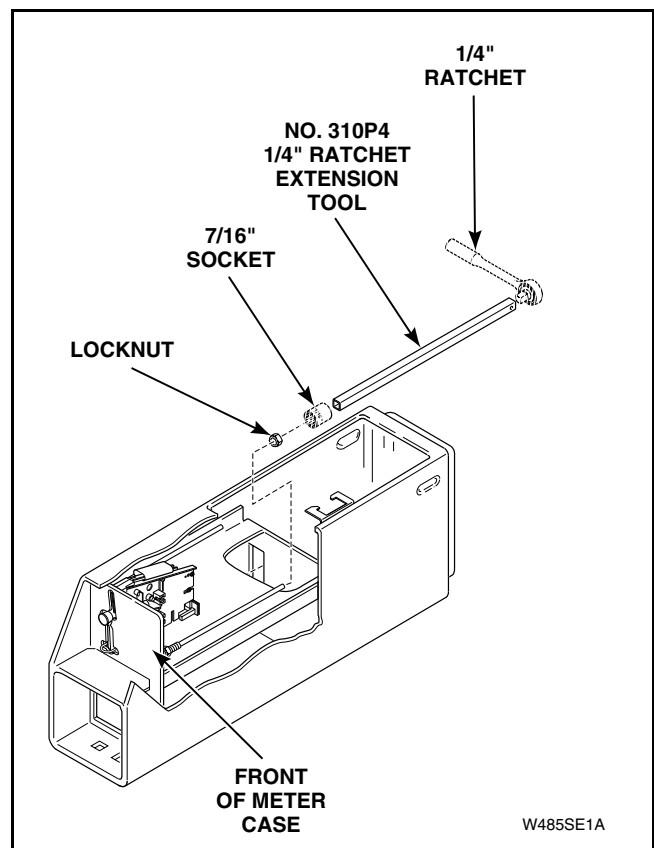

Figure 14



WARNING

To reduce the risk of electric shock, fire, explosion, serious injury or death:

- Disconnect electric power to the washer before servicing.
- Never start the washer with any guards/panels removed.
- Whenever ground wires are removed during servicing, these ground wires must be reconnected to ensure that the washer is properly grounded.

W003

f. DUAL COIN DROP REMOVAL

- (1) Unlock and open service door.

NOTE: If screw type lock is used, the retainer bracket must be removed from inside meter case.

- (2) Disconnect wire harness from coin drawer switch and disconnect coin drops at disconnect plugs.

- (3) Press in on locking tabs of service door switch and remove switch from bracket on meter case, as shown in *Figure 15*.

- (4) Remove wire harness from multiplier. Refer to *Figure 16*. Move wire harness out of the way.

- (5) Remove multiplier from inside meter case. Refer to *Figure 16*.

NOTE: Multiplier is held inside meter case by two Velcro strips.

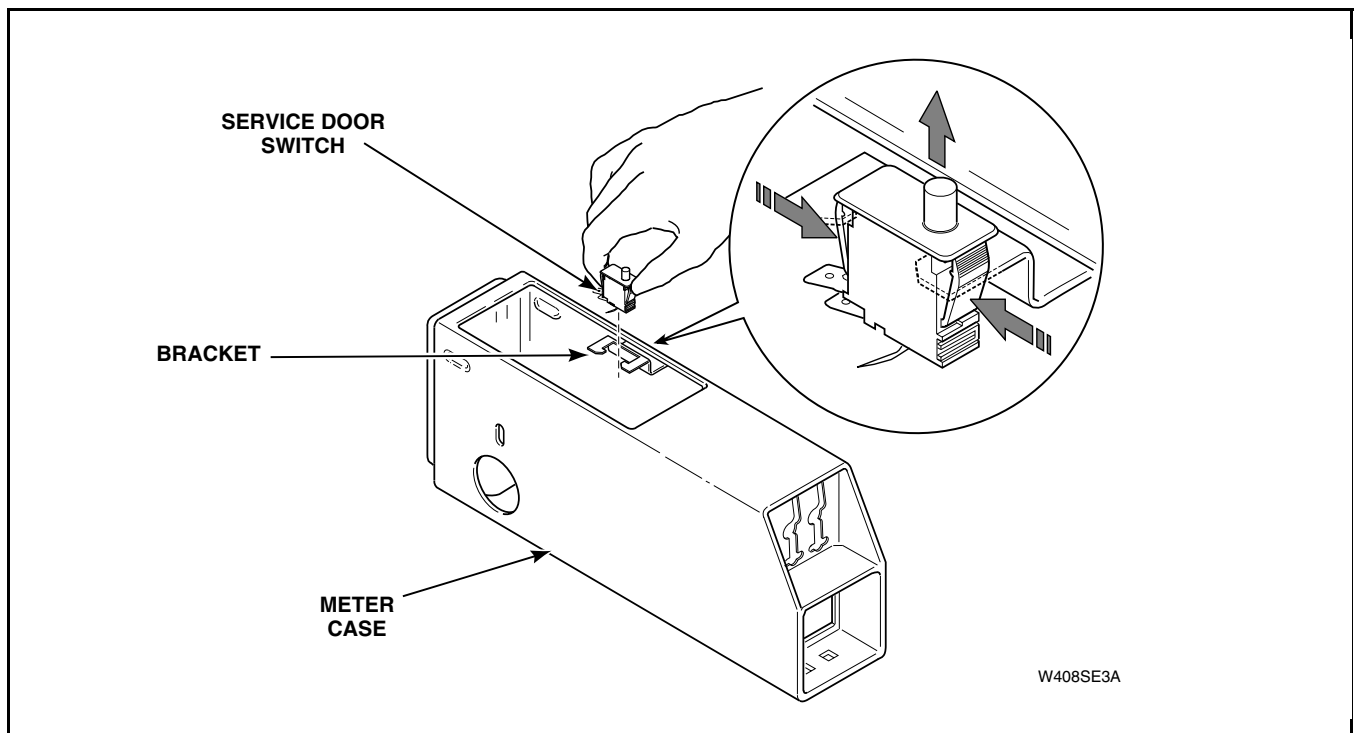

Figure 15



WARNING

To reduce the risk of electric shock, fire, explosion, serious injury or death:

- Disconnect electric power to the washer before servicing.
- Never start the washer with any guards/panels removed.
- Whenever ground wires are removed during servicing, these ground wires must be reconnected to ensure that the washer is properly grounded.

W003

(6) Press in on locking tabs of coin drawer switch and remove switch through front of meter case. Refer to *Figure 16*.

(7) Use a 7/16 inch socket with No. 310P4 1-4 inch Ratchet Extension Tool and remove two locknuts holding coin drop to front of meter case. Refer to *Figure 16*.

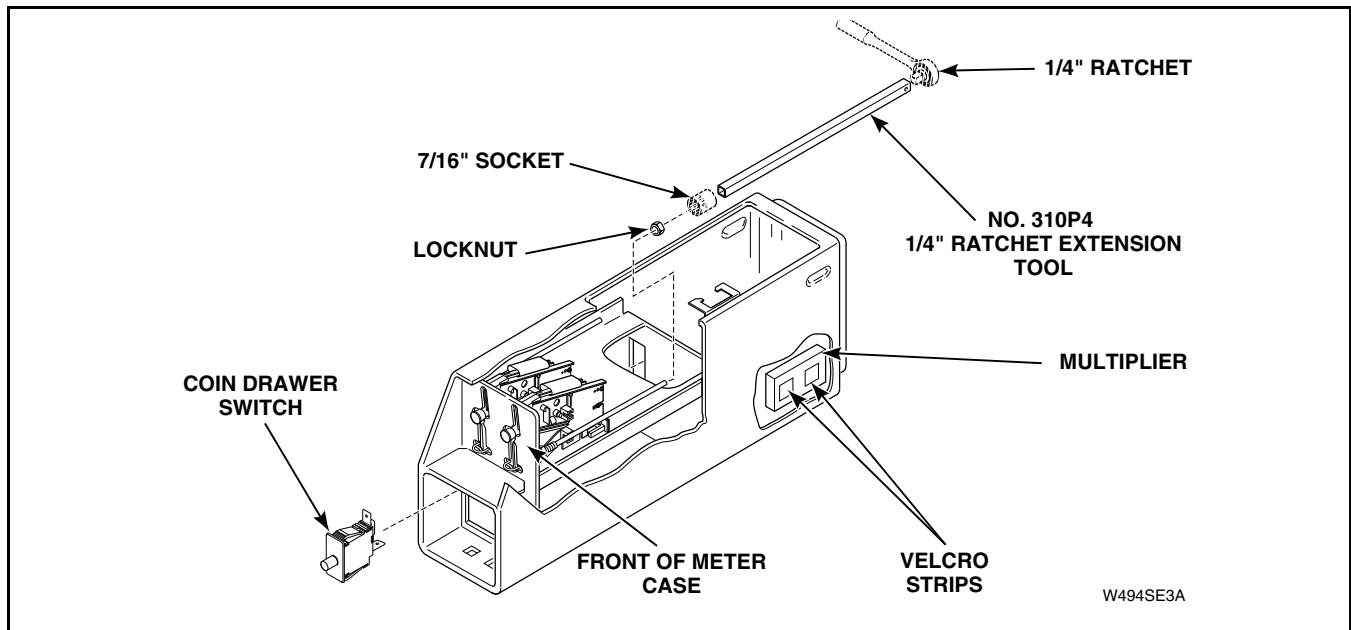

Figure 16

(8) Lift back end of coin drop and pull straight back until bottom edge of the drop's front face plate falls behind the coin drawer housing. Refer to *Figure 17*.

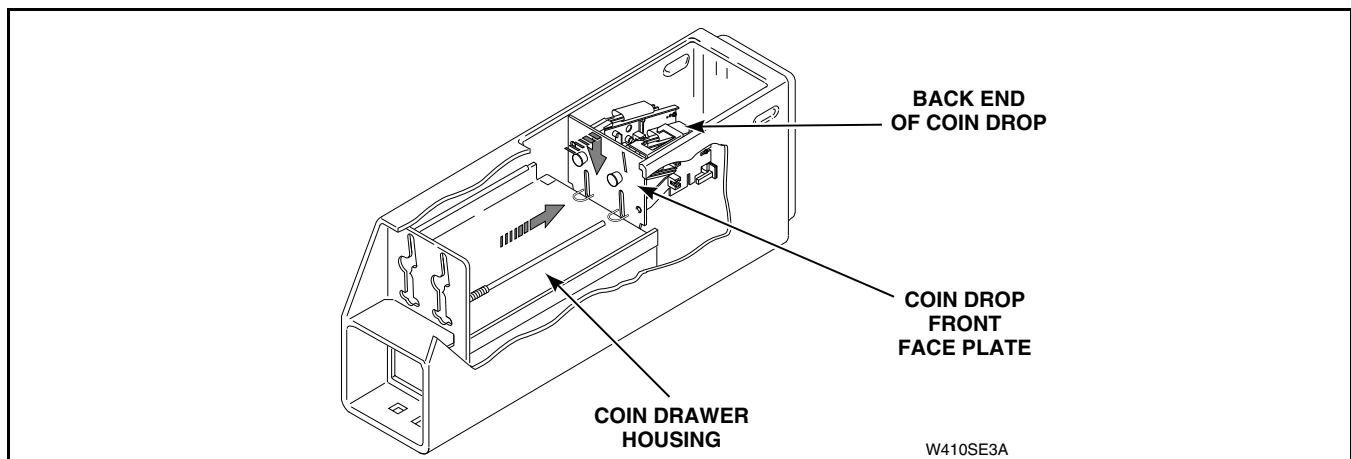

Figure 17



WARNING

To reduce the risk of electric shock, fire, explosion, serious injury or death:

- Disconnect electric power to the washer before servicing.
- Never start the washer with any guards/panels removed.
- Whenever ground wires are removed during servicing, these ground wires must be reconnected to ensure that the washer is properly grounded.

W003

(9) Lift up back end of coin drop until the two coin-return stops slide down past the coin drawer housing, as shown in *Figure 18*.

(10) While holding back end of drop, allow drop's front face plate to rest on bottom of meter case. Refer to *Figure 18*.

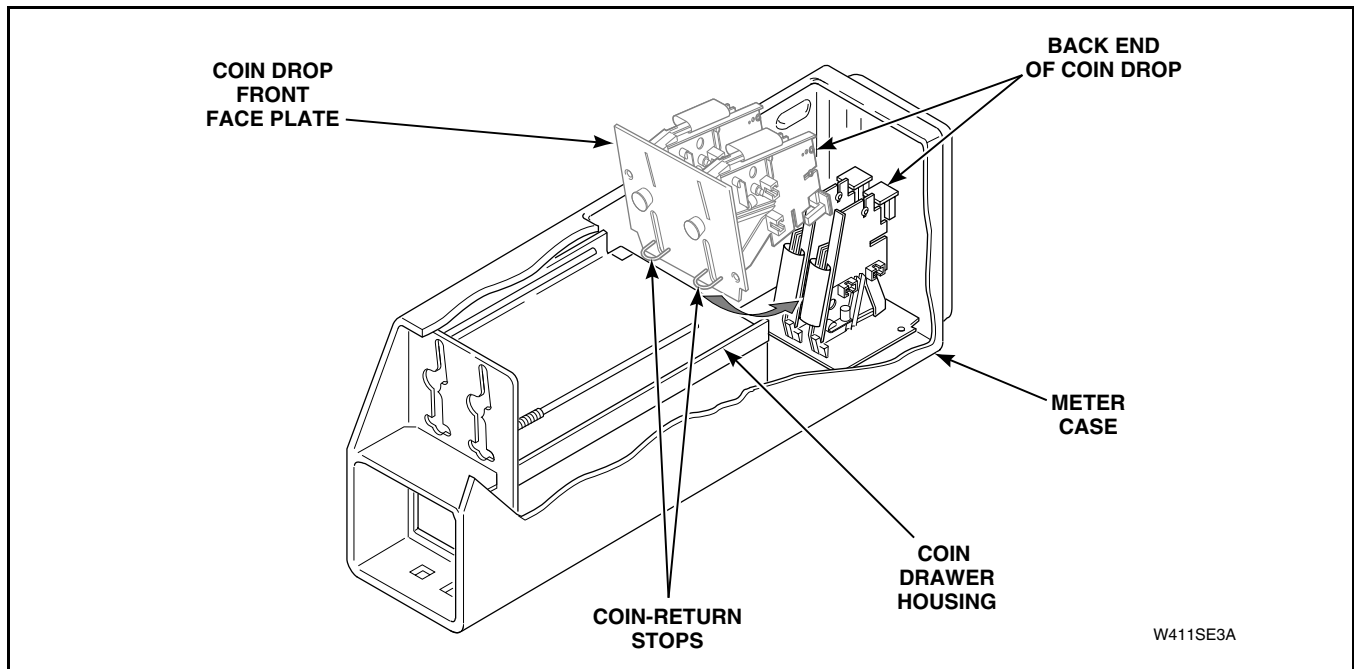

Figure 18



WARNING

To reduce the risk of electric shock, fire, explosion, serious injury or death:

- Disconnect electric power to the washer before servicing.
- Never start the washer with any guards/panels removed.
- Whenever ground wires are removed during servicing, these ground wires must be reconnected to ensure that the washer is properly grounded.

W003

(11) Carefully lift complete coin drop straight up and out of meter case. Refer to *Figure 19*.

NOTE: When lifting drop out of meter case, tip drop slightly so front face plate clears service door opening. Refer to *Figure 19*.

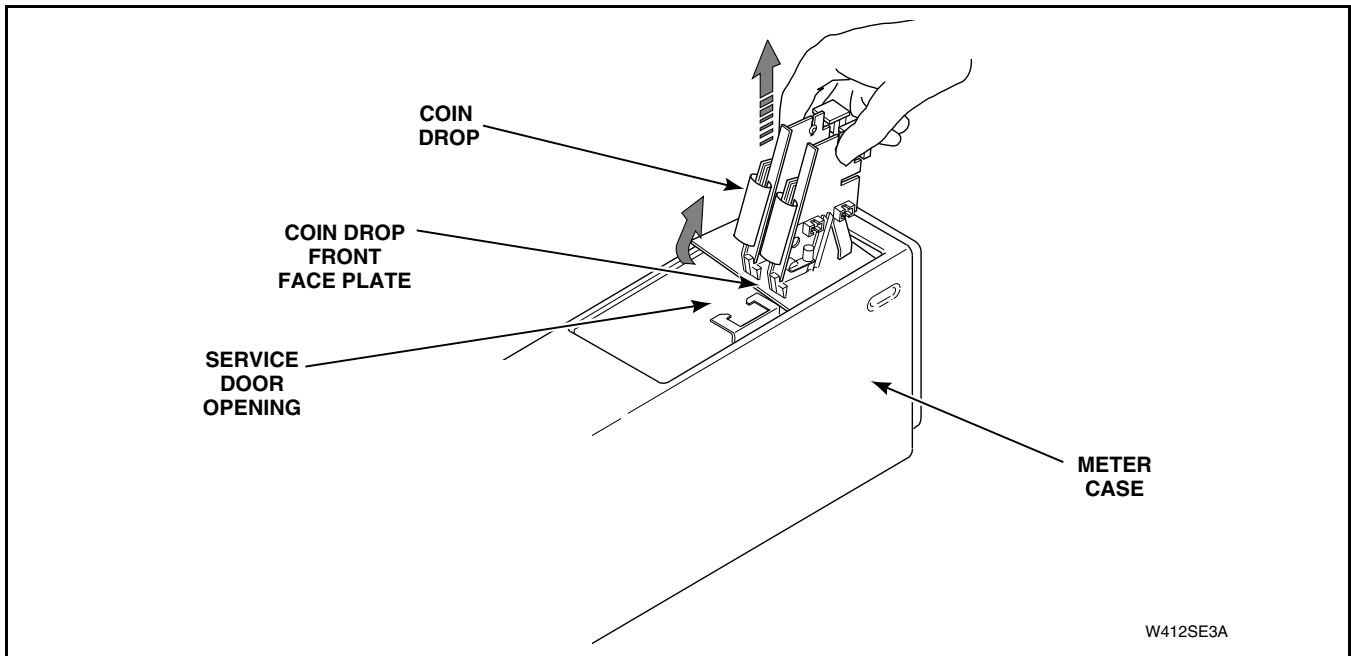

Figure 19



WARNING

To reduce the risk of electric shock, fire, explosion, serious injury or death:

- Disconnect electric power to the washer before servicing.
- Never start the washer with any guards/panels removed.
- Whenever ground wires are removed during servicing, these ground wires must be reconnected to ensure that the washer is properly grounded.

W003

g. DUAL COIN DROP INSTALLATION

- (1) Gently work new coin drop into meter case with the drop's front face plate down. Refer to *Figure 20*.

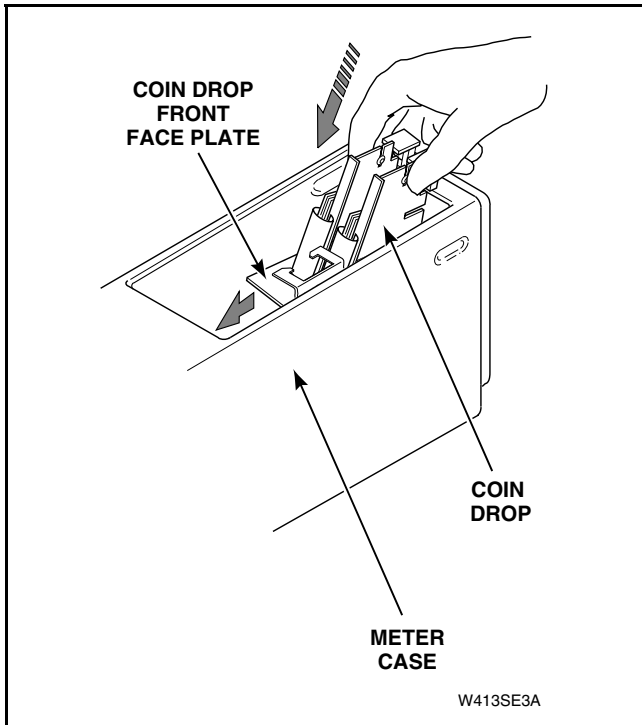

Figure 20

- (2) Carefully pull front of coin drop up and forward, so the drop's front face plate clears the meter case's door switch bracket. Refer to *Figure 21*.
- (3) Rest the two coin-return stops on top of the coin drawer housing, as shown in *Figure 22*.
- (4) Grasp top of coin drop front face plate between the two drops, as shown in *Figure 21*.

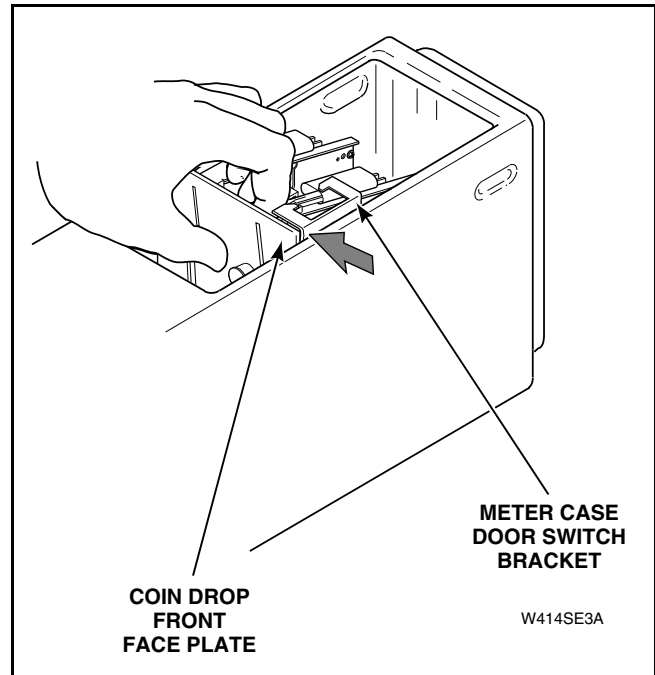

Figure 21

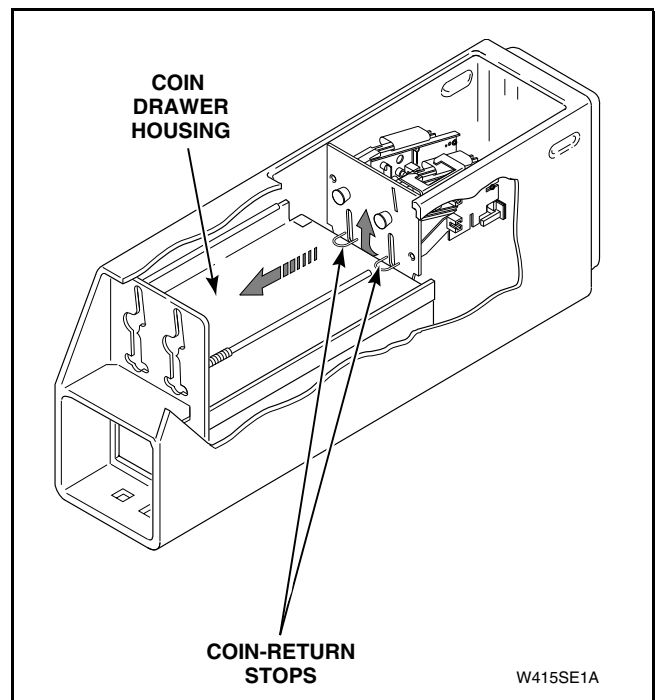

Figure 22



WARNING

To reduce the risk of electric shock, fire, explosion, serious injury or death:

- Disconnect electric power to the washer before servicing.
- Never start the washer with any guards/panels removed.
- Whenever ground wires are removed during servicing, these ground wires must be reconnected to ensure that the washer is properly grounded.

W003

- (5) Lift up front face plate of coin drop with one hand, while gently pushing down rear of drop with other hand, so the bottom of the drop's front face plate clears coin drawer housing. Refer to *Figure 23*.

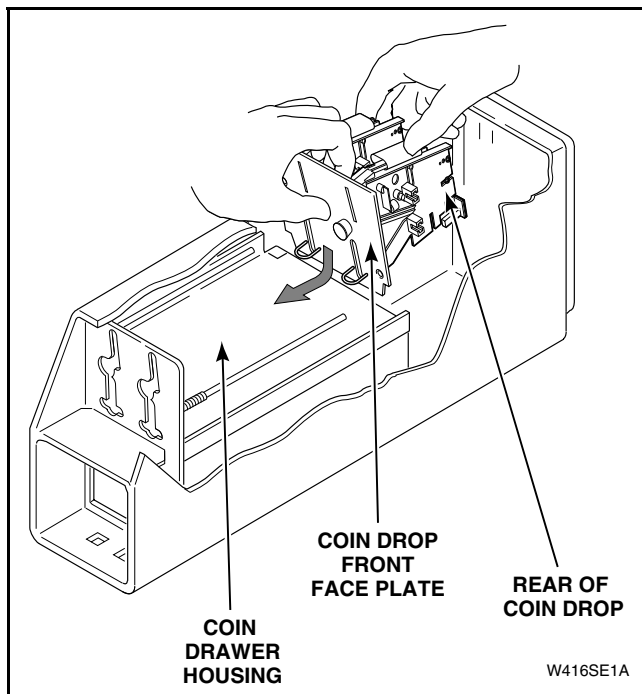

Figure 23

- (11) Reinstall multiplier and reconnect wires. Refer to *Figure 16*.
 (12) Close and lock service door.

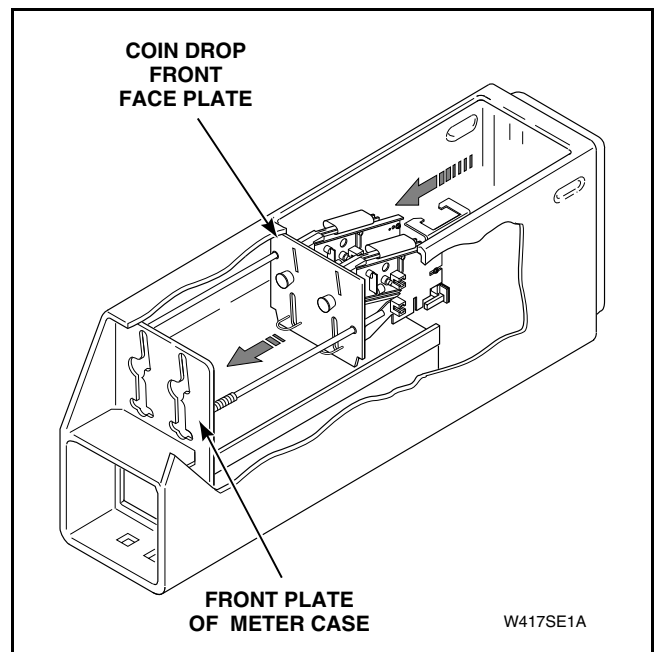

Figure 24

- (6) Carefully slide coin drop forward into position, as shown in *Figure 24*. (Front face plate of coin drop should be secure against front plate of meter case.)
- (7) Using a 7/16 inch socket with No. 310P4 1/4 inch Ratchet Extension Tool, reinstall the two locknuts previously removed. Tighten locknuts firmly.
- (8) Reinstall coin drawer switch previously removed.
- (9) Reconnect wires by referring to the wiring diagram located inside the control hood.
- (10) Reinstall service door switch and wire harness into meter case bracket. Refer to *Figure 15*.



WARNING

To reduce the risk of electric shock, fire, explosion, serious injury or death:

- Disconnect electric power to the washer before servicing.
- Never start the washer with any guards/panels removed.
- Whenever ground wires are removed during servicing, these ground wires must be reconnected to ensure that the washer is properly grounded.

W003

23. METER OR TIMER CASE ASSEMBLY

a. METER CASE REMOVAL (Metered Models):

- (1) Remove two control panel attaching screws. Refer to *Figure 5*. Lay assembly forward on protective pad on cabinet top.
- (2) Disconnect timer harness from control hood harness at disconnect blocks. Refer to *Figure 6*.
- (3) Unlock and remove meter case service door.
- (4) Remove timer bracket cap screw. Refer to *Figure 9*.
- (5) Slide timer and bracket toward rear of meter case to disengage bracket from shoulder screw. Lift timer and bracket out of meter case through service door opening as far as wires will permit.
- (6) Disengage wire harness terminal block plug from timer by pressing in movable locking tabs (located on each side of terminal block plug). Refer to *Figure 10*. Then pull terminal block plug away from timer.
- (7) Disconnect ground wire from terminal on timer. Refer to *Figure 10*.
- (8) Remove cap screw, lockwashers and nut holding meter case to end of control hood.
- (9) Remove coin drawer.
- (10) Remove shoulder screw from inside meter case.

NOTE: When installing meter case, shoulder screw must be installed in outer hole. Refer to *Figure 9*, to enable timer bracket to slide under screw head.

- (11) Remove two screws from bottom edge of front panel. Refer to *Figure 37*.
- (12) Pull bottom of panel away from washer until hold down clips (located on top flange of panel) disengage from slots in cabinet top.
- (13) Remove carriage bolts and locknuts holding meter case to cabinet top.
- (14) Carefully remove meter case and gasket from cabinet top.

b. TIMER CASE REMOVAL (Nonmetered Models):

- (1) Remove four screws and lockwashers holding timer and plate to timer case. Refer to *Figure 12*.

NOTE: When reinstalling timer and plate, lockwashers must be between head of screws and timer plate.

- (2) Pull timer and plate out of timer case as far as wires will permit.

NOTE: Disconnect ground wire from ground terminal on timer.

- (3) Pull wire harness and blocks through into timer case; then disconnect timer harness from control hood harness at quick disconnect block.
- (4) Remove two control panel attaching screws. Refer to *Figure 5*. Lay assembly forward on a protective pad on cabinet top.
- (5) Remove cap screw, lockwashers and nut holding timer case to control hood. Refer to *Figure 25*.
- (6) Remove two cabinet top hold down screws. Refer to *Figure 37*.
- (7) Tape loading door closed and lift cabinet top to a vertical position.
- (8) Remove carriage bolts, vinyl washers, lockwashers and nuts holding timer case to cabinet top.
- (9) Support timer case and remove screw and fiber washer holding rear of case to cabinet top.

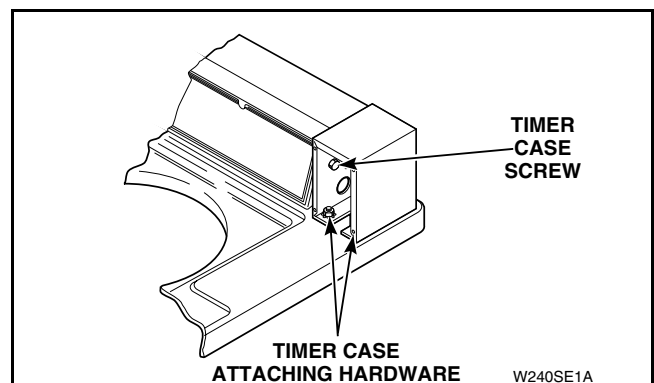

Figure 25

W240SE1A



WARNING

To reduce the risk of electric shock, fire, explosion, serious injury or death:

- Disconnect electric power to the washer before servicing.
- Never start the washer with any guards/panels removed.
- Whenever ground wires are removed during servicing, these ground wires must be reconnected to ensure that the washer is properly grounded.

W003

24. DRAIN HOSE ELBOW

- a. Loosen hose clamp and remove drain hose from elbow. Refer to *Figure 26*.
- b. Remove screws holding elbow to rear of washer cabinet. Refer to *Figure 26*.
- c. Pull elbow out through opening in cabinet far enough to loosen inner clamp, then remove elbow from inner hose.

NOTE: When installing elbow on inner hose, **DO NOT** allow hose inside of washer to twist! Direct elbow toward drain receptacle and secure elbow to washer cabinet.

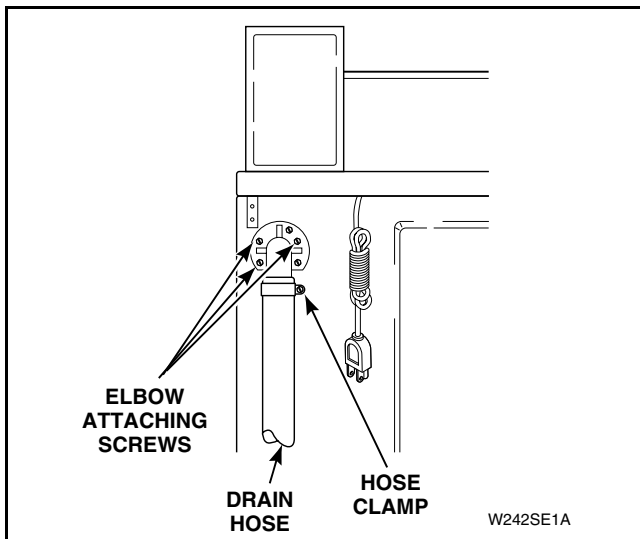

Figure 26

25. LOADING DOOR

- a. Open loading door. Refer to *Figure 27*.
- b. Remove two screws holding left hinge to door and remove hinge. Refer to *Figure 27*.
- c. With loading door raised to vertical position, swing left side of door toward front of washer. Refer to *Figure 28*, **procedure one**.
- d. Rotate loading door so door is upside down. Refer to *Figure 28*, **procedure two**.
- e. Remove loading door, right door hinge and bushing from cabinet top. Refer to *Figure 28*, **procedure three**.

NOTE: Reverse procedures when installing loading door.

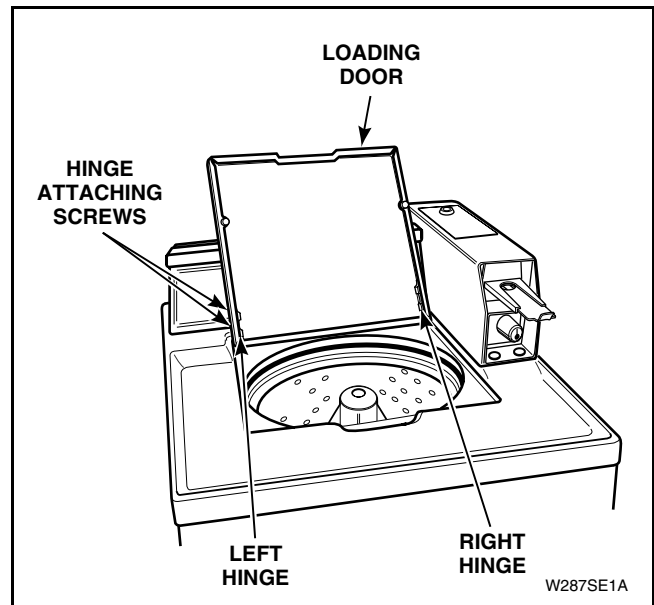
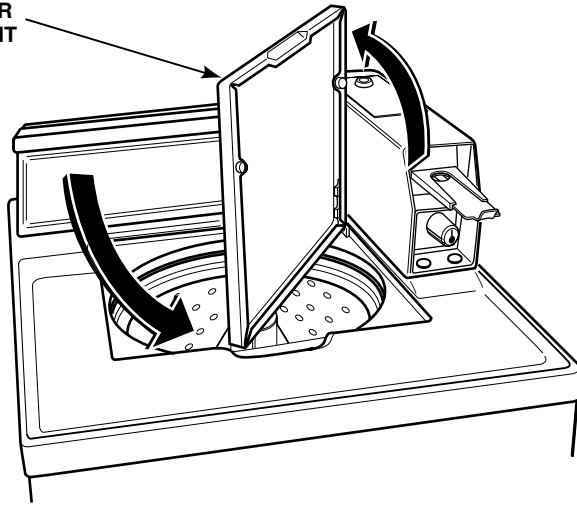

Figure 27

Procedure One

DOOR
FRONT



W288SE3A

Procedure Two

DOOR
FRONT

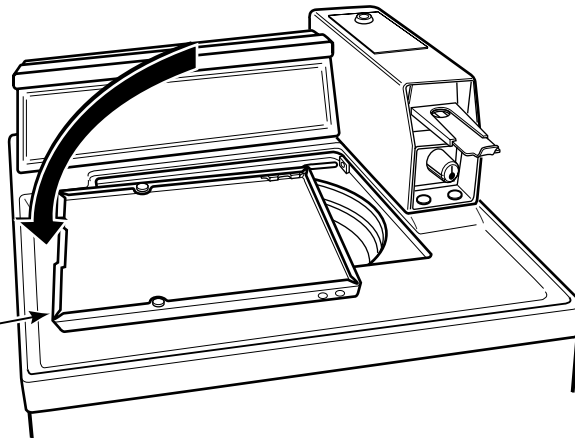

W289SE3A

Procedure Three

DOOR
FRONT

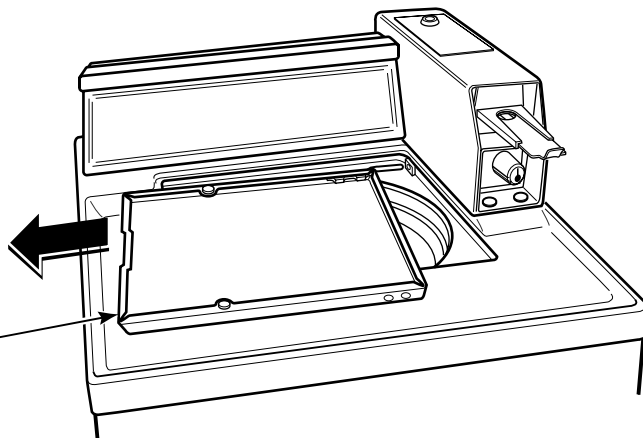

W290SE3A

Figure 28



WARNING

To reduce the risk of electric shock, fire, explosion, serious injury or death:

- Disconnect electric power to the washer before servicing.
- Never start the washer with any guards/panels removed.
- Whenever ground wires are removed during servicing, these ground wires must be reconnected to ensure that the washer is properly grounded.

W003

26. AGITATOR

- Open loading door.
- Remove agitator by placing two agitator hooks, No. 254P4P, under bottom edge of agitator. Refer to *Figure 29*.

IMPORTANT: Hooks should be positioned 180 degrees from each other, and must be placed under base of agitator near agitator vane for greater stability. If hooks are placed between the vane area, agitator damage may occur.

- Using a rocking motion (back and forth) carefully lift agitator off drive bell.

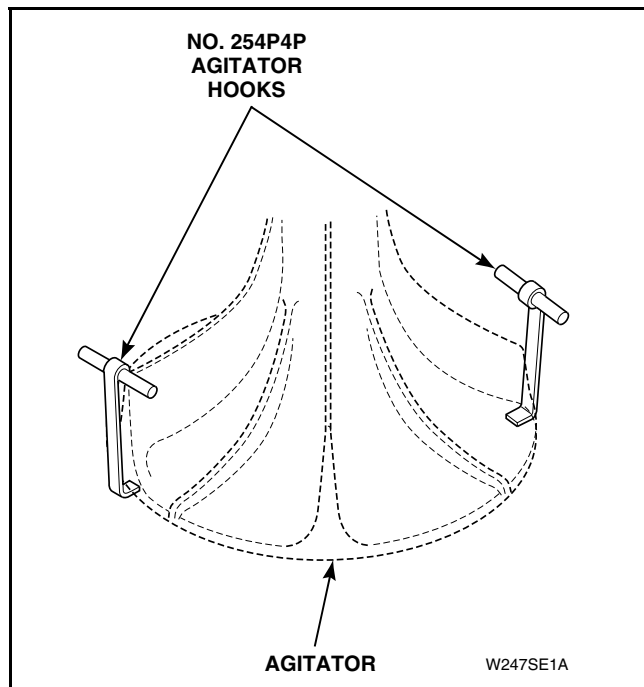

Figure 29

27. AGITATOR, DRIVE BELL AND SEAL ASSEMBLY

IMPORTANT: If water is present in washtub, spin and pump out before attempting to remove drive bell.

- Open loading door.
- Remove agitator by placing two agitator hooks, No. 254P4P, under bottom edge of agitator. Refer to *Figure 29*.

IMPORTANT: Hooks should be positioned 180 degrees from each other, and must be placed under base of agitator near agitator vane for greater stability. If hooks are placed between the vane area, agitator damage may occur.

- Using a rocking motion (back and forth) carefully lift agitator off drive bell.
- Remove plug, screw (and "O" ring if present) from top of drive bell.

NOTE: Use No. 294P4 Drive Bell Tool to remove drive bell from transmission shaft.

NOTE: Drive Bell Tool, No. 253P4, must be updated with Jaws, No. 294P4A, and Bolt, No. 294P4B, to remove drive bell.

- Back bolt out of 294P4 Drive Bell Tool approximately three quarters of the way. Refer to *Figure 30*.
- Place tool over drive bell, making sure indent on jaws line up with wide slots on drive bell. Refer to *Figure 31*.



WARNING

To reduce the risk of electric shock, fire, explosion, serious injury or death:

- Disconnect electric power to the washer before servicing.
- Never start the washer with any guards/panels removed.
- Whenever ground wires are removed during servicing, these ground wires must be reconnected to ensure that the washer is properly grounded.

W003

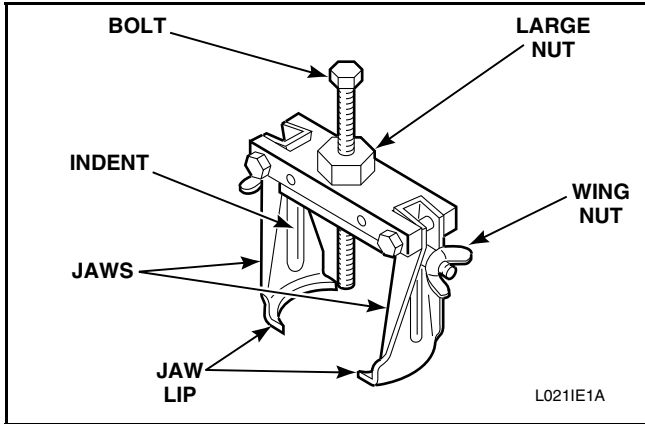

Figure 30

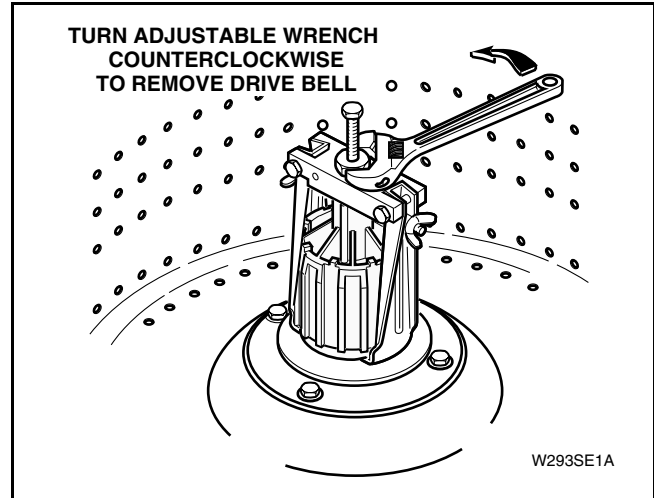

Figure 32

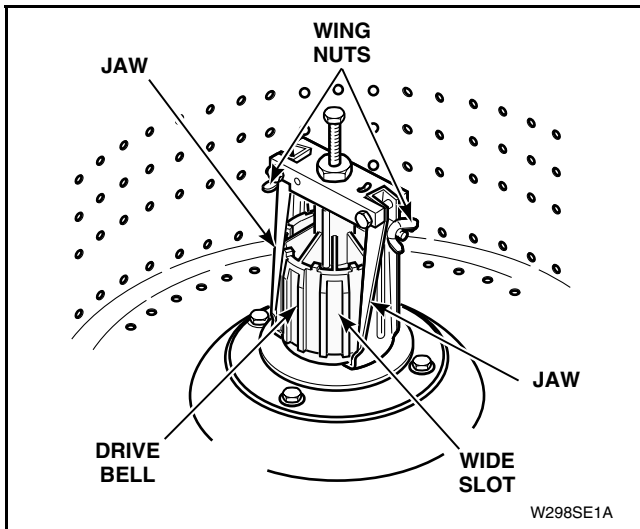

Figure 31

IMPORTANT: If large nut is turned clockwise when pulling drive bell, you will twist off the quarter inch bolt.

- j. After drive bell has been pulled, remove tool and drive bell by turning quarter inch bolt out of transmission output shaft.
 - k. Loosen wing nuts and remove drive bell from tool.
 1. Remove old seal from hub assembly by:
 - (1) Placing a flat bladed screwdriver between bottom edge of seal and hub.
 - (2) Using washtub bolts as a pry area, pop off lower seal bead.
 - (3) Grasping bottom of seal pull straight up freeing upper seal bead.
 - m. Thoroughly clean all foreign material from seal mounting area of hub assembly, bronze bearing and washer. Refer to *Figure 33*.
 - n. Lubricate new seal with liquid soap or soapy water to aid in assembly of seal onto hub. Refer to *Figure 34*.
 - o. Apply a small amount of supplied grease, No. 36765P, to inside sealing lips of seal. Refer to *Figure 34*.
- g. Thread bolt down through hole in top of drive bell until it bottoms out.
 - h. Place lip of each jaw under bottom edge of drive bell, making sure indent on jaws line up with wide slots on drive bell. Tighten wing nuts on tool to hold jaws firmly against drive bell. Refer to *Figure 31*.
 - i. Using an adjustable wrench, turn large nut on tool **COUNTERCLOCKWISE** to pull drive bell from transmission output shaft. Refer to *Figure 32*.



WARNING

To reduce the risk of electric shock, fire, explosion, serious injury or death:

- Disconnect electric power to the washer before servicing.
- Never start the washer with any guards/panels removed.
- Whenever ground wires are removed during servicing, these ground wires must be reconnected to ensure that the washer is properly grounded.

W003

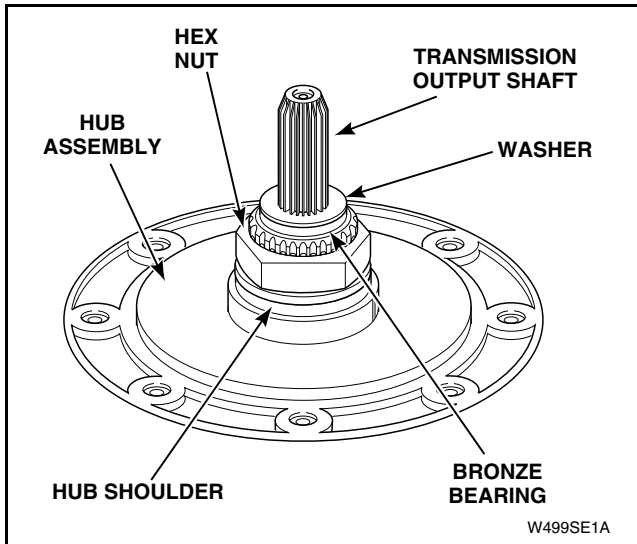

Figure 33

IMPORTANT: DO NOT allow any lubricants to come in contact with outside surface of seal.

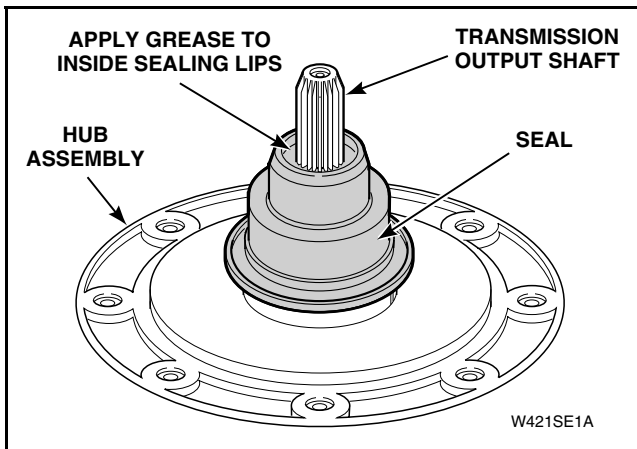

Figure 34

- p. Apply remainder of supplied grease, No. 36765P, to exposed surface of washer between transmission output shaft and seal. Refer to *Figure 36*.
- q. Place new drive bell seal onto hub and carefully push into position using large end of No. 293P4 Seal Tool. Refer to *Figure 35*.

IMPORTANT: Using a small pocket mirror, check entire circumference of bottom seal flange to make sure seal is pressed down against shoulder on hub; there should be no gap!

- r. Turn the No. 293P4 Seal Tool upside-down and place the small end over transmission output shaft and onto the seal. Refer to *Figure 36*.
- s. Push down on tool with a quick motion until it bottoms out and the top of seal is fully seated. Refer to *Figure 36*.

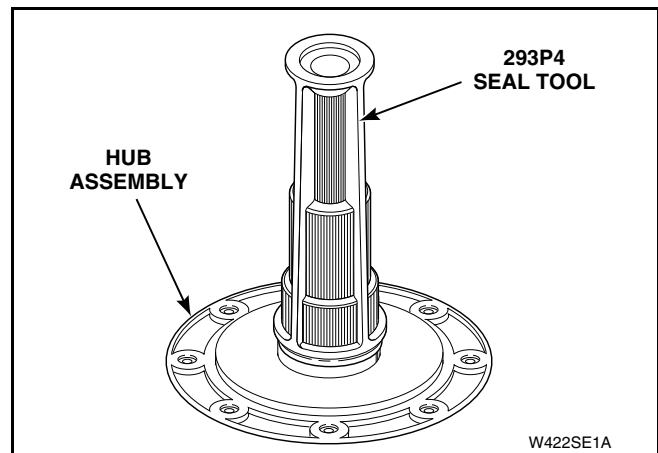

Figure 35

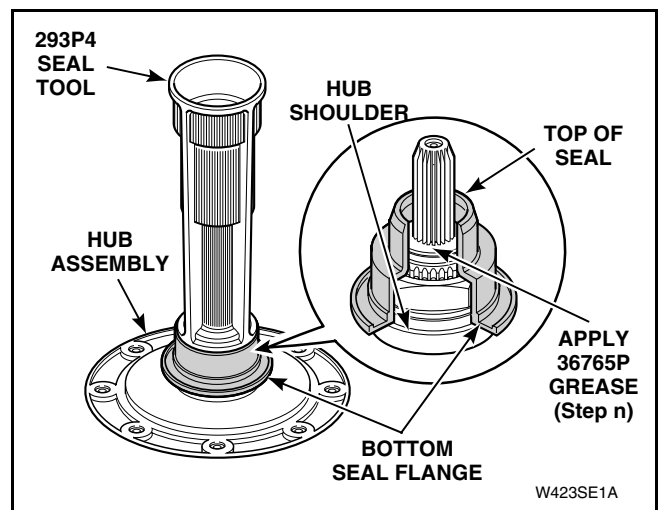

Figure 36



WARNING

To reduce the risk of electric shock, fire, explosion, serious injury or death:

- Disconnect electric power to the washer before servicing.
- Never start the washer with any guards/panels removed.
- Whenever ground wires are removed during servicing, these ground wires must be reconnected to ensure that the washer is properly grounded.

W003

INSTALLING DRIVE BELL

- a. Position new drive bell over transmission output shaft. Rotate drive bell until splines in drive bell line up with splines on transmission output shaft.
- b. Place No. 294P4 Bell Tool over top of drive bell. Screw bolt into transmission output shaft until it bottoms out.

NOTE: It is not necessary to clamp tool jaws on drive bell during this operation.

- c. Using an adjustable wrench, turn large nut on tool **CLOCKWISE** to force drive bell down onto transmission shaft until drive bell bottoms out on shaft.
- d. Turn quarter inch bolt out of transmission shaft and remove tool.
- e. Thread new shoulder screw down through hole in top of drive bell and into transmission shaft.

NOTE: Tighten new shoulder screw to approximately 60 to 80 inch-pounds (6.86 to 9.15 N-m).

- f. Place new plug over hole in drive bell and firmly press into place using palm of your hand.

NOTE: It may be necessary to insert the end of a paper clip along side of plug as it is pressed into drive bell to release entrapped air.

IMPORTANT: When fully seated plug should not extend above drive bell more than 1/8 inch (3.2 mm).

- g. Place agitator on top of drive bell. Slowly rotate agitator until fingers on underside of agitator line up with large slots on drive bell.
- h. A sharp blow on top of agitator, with palm of your hand, will force agitator down onto drive bell, allowing fingers on underside of agitator to lock under bottom edge of drive bell.

NOTE: Do not push agitator onto drive bell any further than necessary.



WARNING

To reduce the risk of electric shock, fire, explosion, serious injury or death:

- Disconnect electric power to the washer before servicing.
- Never start the washer with any guards/panels removed.
- Whenever ground wires are removed during servicing, these ground wires must be reconnected to ensure that the washer is properly grounded.

W003

28. FRONT PANEL

Refer to *Figure 37*

- a. Remove two screws from bottom edge of front panel. Refer to *Figure 37*.
- b. Pull bottom of panel away from washer until hold down clips (located on top flange of panel) disengage from slots in cabinet top.

Hold Down Clips

Compress hold down clips enough to remove them from slots in top flange of panel.

Panel Locators

Remove screws holding panel locators to side flanges of front panel.

Brace

Remove screws holding brace to side flanges of front panel. Remove brace from front panel by swinging one end toward bottom of front panel and remove brace.

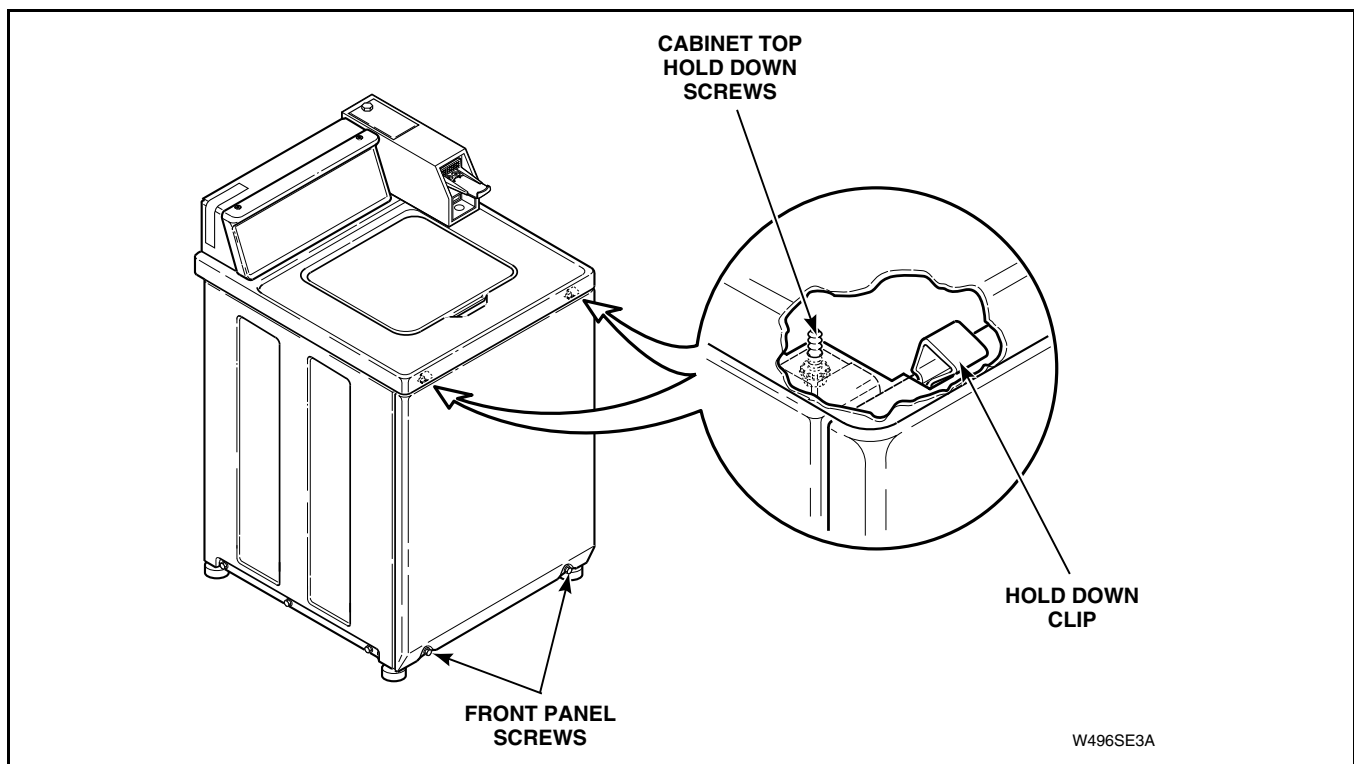

Figure 37



WARNING

To reduce the risk of electric shock, fire, explosion, serious injury or death:

- Disconnect electric power to the washer before servicing.
- Never start the washer with any guards/panels removed.
- Whenever ground wires are removed during servicing, these ground wires must be reconnected to ensure that the washer is properly grounded.

W003

29. CABINET TOP ASSEMBLY

- a. Remove two screws from bottom edge of front panel. Refer to *Figure 37*.
- b. Pull bottom of panel away from washer until hold down clips (located on top flange of panel) disengage from slots in cabinet top.
- c. **METERED MODELS:**
 - (1) Unlock and remove meter case service door.
 - (2) Remove timer bracket cap screw. Refer to *Figure 8*.
 - (3) Slide timer and bracket toward rear of meter case to disengage bracket from shoulder screw. Lift timer and bracket out of meter case through service door opening as far as wires will permit.
 - (4) Remove shoulder screw from inside meter case.
 - (5) Remove two cabinet top hold down screws. Refer to *Figure 37*.
 - (6) Remove security bolt (if present) from left rear corner of cabinet top.

NOTE: When lowering cabinet top into position or reinstalling cabinet top, pivot outer tub forward far enough to prevent damaging (bending) loading door switch lever.

- d. Tape loading door closed and lift cabinet top to a vertical position by hinging it on the rear hinges.

NOTE: Cabinet top is self supporting, however, a small chain may be used for additional support. Refer to *Figure 38*.

TO REMOVE CABINET TOP FROM WASHER

- a. Remove two control panel attaching screws. Refer to *Figure 5*. Lay assembly forward on a protective pad on cabinet top.
- b. Disconnect pressure hose from pressure switch. Refer to *Figure 6*.

IMPORTANT: When installing pressure hose, blow air into hose before connecting hose to switch to remove any moisture that may have accumulated in the hose.

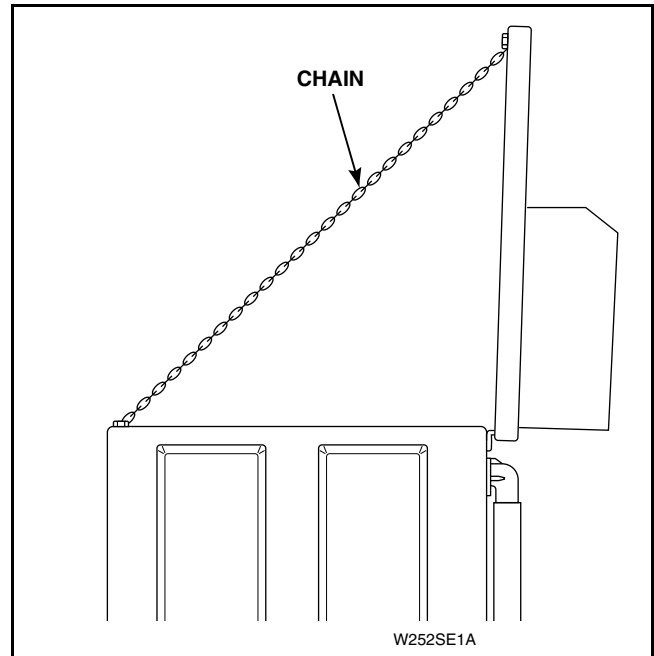

Figure 38

- c. Push base wire harness block and pressure hose down through hole in cabinet top.
- d. Tape loading door closed.
- e. Reinstall control panel and screws.
- f. Remove two screws from bottom edge of front panel. Refer to *Figure 37*.
- g. Pull bottom of panel away from washer until hold-down clips (located on top flange of panel) disengage from slots in cabinet top.
- h. **METERED MODELS:**
 - (1) Unlock and remove meter case service door.
 - (2) Remove timer bracket cap screw. Refer to *Figure 9*.
 - (3) Slide timer and bracket toward rear of meter case to disengage bracket from shoulder screw. Lift timer and bracket out of meter case through service door opening as far as wires will permit.
 - (4) Remove shoulder screw from inside meter case.
 - (5) Remove two cabinet top hold down screws. Refer to *Figure 37*.



WARNING

To reduce the risk of electric shock, fire, explosion, serious injury or death:

- Disconnect electric power to the washer before servicing.
- Never start the washer with any guards/panels removed.
- Whenever ground wires are removed during servicing, these ground wires must be reconnected to ensure that the washer is properly grounded.

W003

(6) Remove security bolt (if present) from left rear corner of cabinet top.

k. Carefully lift cabinet top off washer and set on protective padding.

NOTE: When lowering cabinet top into position or reinstalling cabinet top, pivot outer tub forward far enough to prevent damaging (bending) loading door switch lever.

- Lift front of cabinet top slightly and pull forward to disengage from rear hinges.
- Pull top forward far enough to permit disconnecting ground wires from top rear corner gusset of washer cabinet. Refer to *Figure 39*. Disconnect wires from mixing valve solenoids at rear of washer.

NOTE: Refer to appropriate wiring diagram when rewiring mixing valve solenoids.



WARNING

To reduce the risk of serious injury, be careful not to damage door switch when removing cabinet top.

W180

IMPORTANT: When reinstalling cabinet top and before lowering top into position, pivot outer tub forward far enough to prevent damaging (bending) door switch lever.

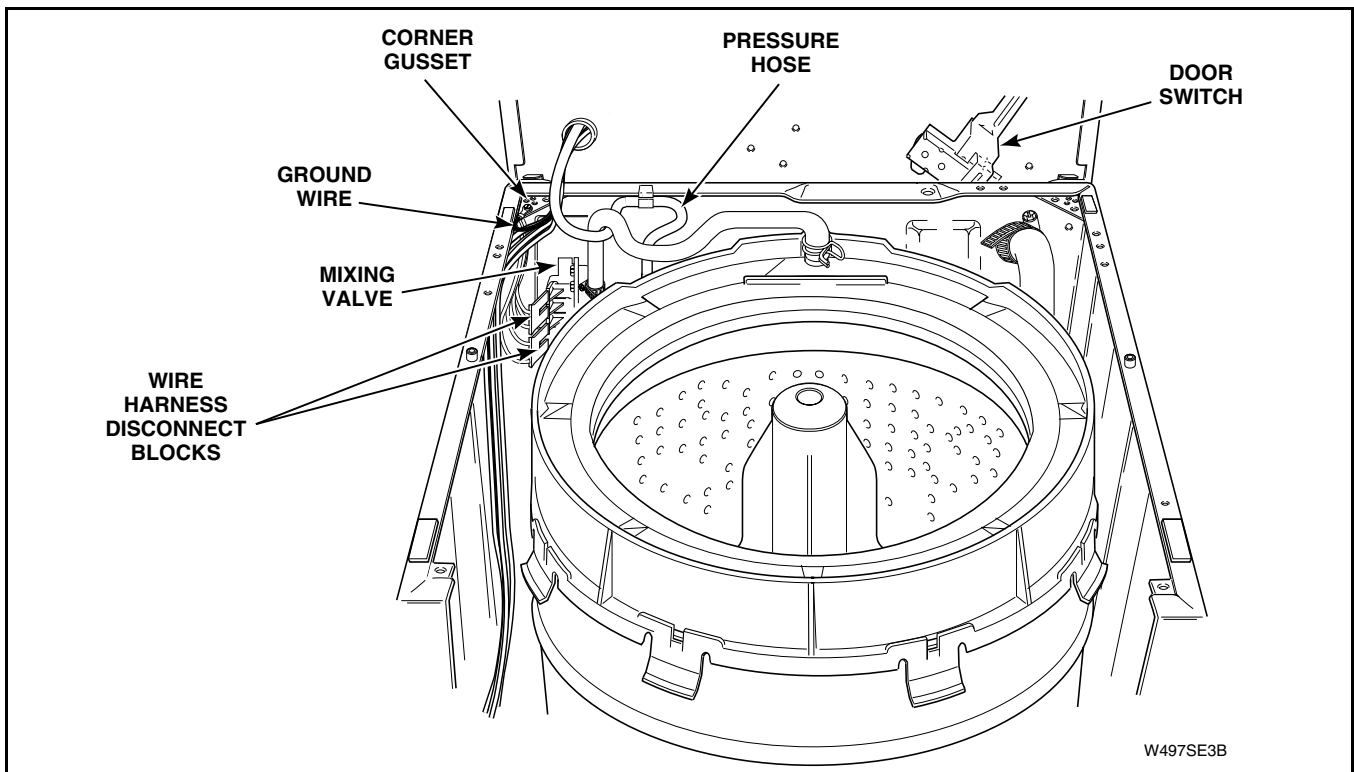

W497SE3B

Figure 39



WARNING

To reduce the risk of electric shock, fire, explosion, serious injury or death:

- Disconnect electric power to the washer before servicing.
- Never start the washer with any guards/panels removed.
- Whenever ground wires are removed during servicing, these ground wires must be reconnected to ensure that the washer is properly grounded.

W003

30. MOTOR AND MOUNTING BRACKET

- a. Remove two screws from bottom edge of front panel. Refer to *Figure 37*.
- b. Pull bottom of panel away from washer until hold down clips (located on top flange of panel) disengage from slots in cabinet top.

IMPORTANT: There will always be some water that will remain in outer tub, therefore, before removing hoses from pump, hoses must be pinched off or drained to prevent water spillage.

- c. Loosen hose clamps and remove hoses from pump assembly. Refer to *Figure 40*.
- d. Unhook idler spring from tab on front of motor mounting bracket. Refer to *Figure 40*.

IMPORTANT: Use care when releasing idler lever tension. If idler spring is overstretched, washer operation will be affected.

- e. Reach in and around right side of motor and run belt off right side of large drive pulley. Refer to *Figure 40*.
- f. Disconnect wire harness from motor switch by pressing down on locking tab on top of connection block and at the same time pull connection block away from motor switch. Refer to *Figure 40*.
- g. Remove four screws holding motor and mounting bracket to lower outer tub flange and to weldment assembly. Refer to *Figure 40*. Then lift complete assembly out of washer.

IMPORTANT: Carefully lay motor on its side. Observe belt configuration around rear pump leg. Belt **MUST** encircle rear pump leg when reassembling. Refer to *Figure 41*.

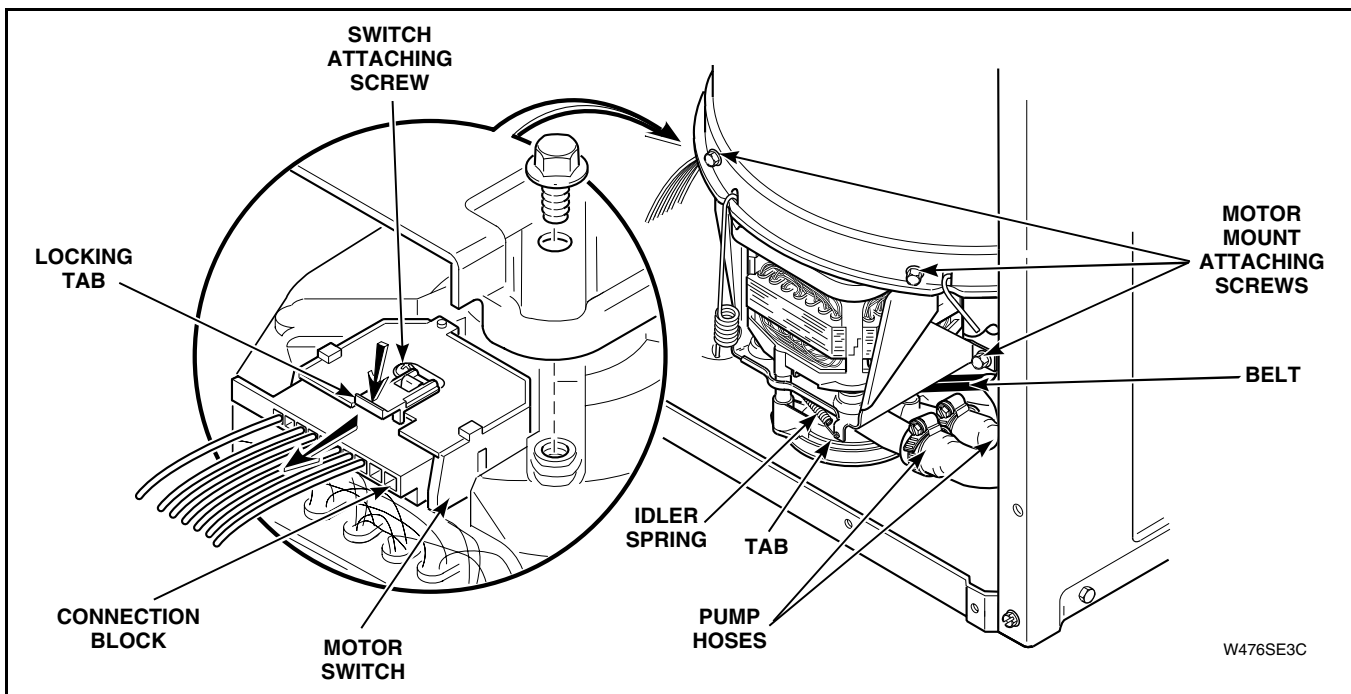

Figure 40

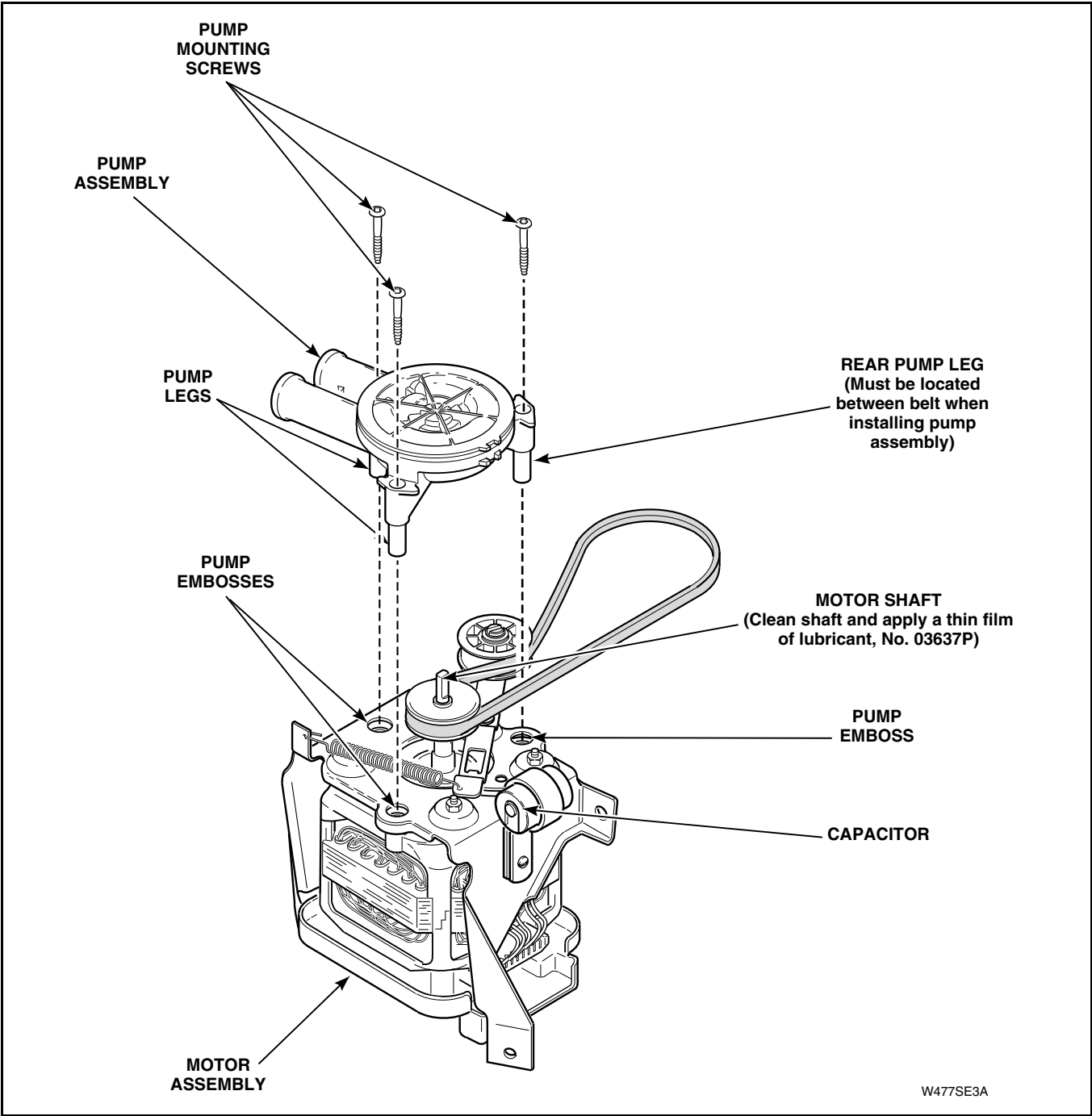

Figure 41



WARNING

To reduce the risk of electric shock, fire, explosion, serious injury or death:

- Disconnect electric power to the washer before servicing.
- Never start the washer with any guards/panels removed.
- Whenever ground wires are removed during servicing, these ground wires must be reconnected to ensure that the washer is properly grounded.

W003

PUMP AND BELT REMOVAL

- a. Remove three screws holding pump assembly to motor. Refer to *Figure 41*.

REASSEMBLY OF PUMP AND BELT

IMPORTANT: Install pump and belt together. Drive belt MUST be replaced with special clutch-type belt for proper washer operation. Refer to parts manual for correct part number of belt.

- a. Clean any corrosion or foreign material from motor shaft that will be contacting the double “D” slot in pump impeller.
- b. Apply a thin film of No. 03637P Lubricant to end and sides of motor shaft. This lubricant helps keep moisture out of the hub area and retards corrosion.
- c. Align pump impeller hub with motor shaft. Make sure belt encircles rear pump leg, carefully push pump onto motor shaft so three pump legs bottom out in the embosses on motor housing before screws are tightened. Refer to *Figure 41*.
- d. Tighten three screws to 35 inch-pounds (4.0 N-m) maximum. DO NOT overtighten screws!
- e. Reinstall motor and pump assembly into washer.

IMPORTANT: After installing motor and pump assembly in washer and all hoses have been reconnected, add at least a quart of water to washtub to lubricate pump seals. Running a pump without water will ruin the seals.

MOTOR REMOVAL

Remove nuts, steel washers, spacers and rubber mounts holding motor to mounting bracket. Refer to *Figure 42*. Lift motor off mounting bracket and remove balance of rubber mounts and steel washers from motor mounting studs.

IMPORTANT: When installing motor on mounting bracket, position motor with switch facing toward left side of mounting bracket. Make sure motor and mounts are centered when reassembling to avoid noise.

NOTE: Refer to *Figure 42* for motor and mounting bracket assembly sequence.

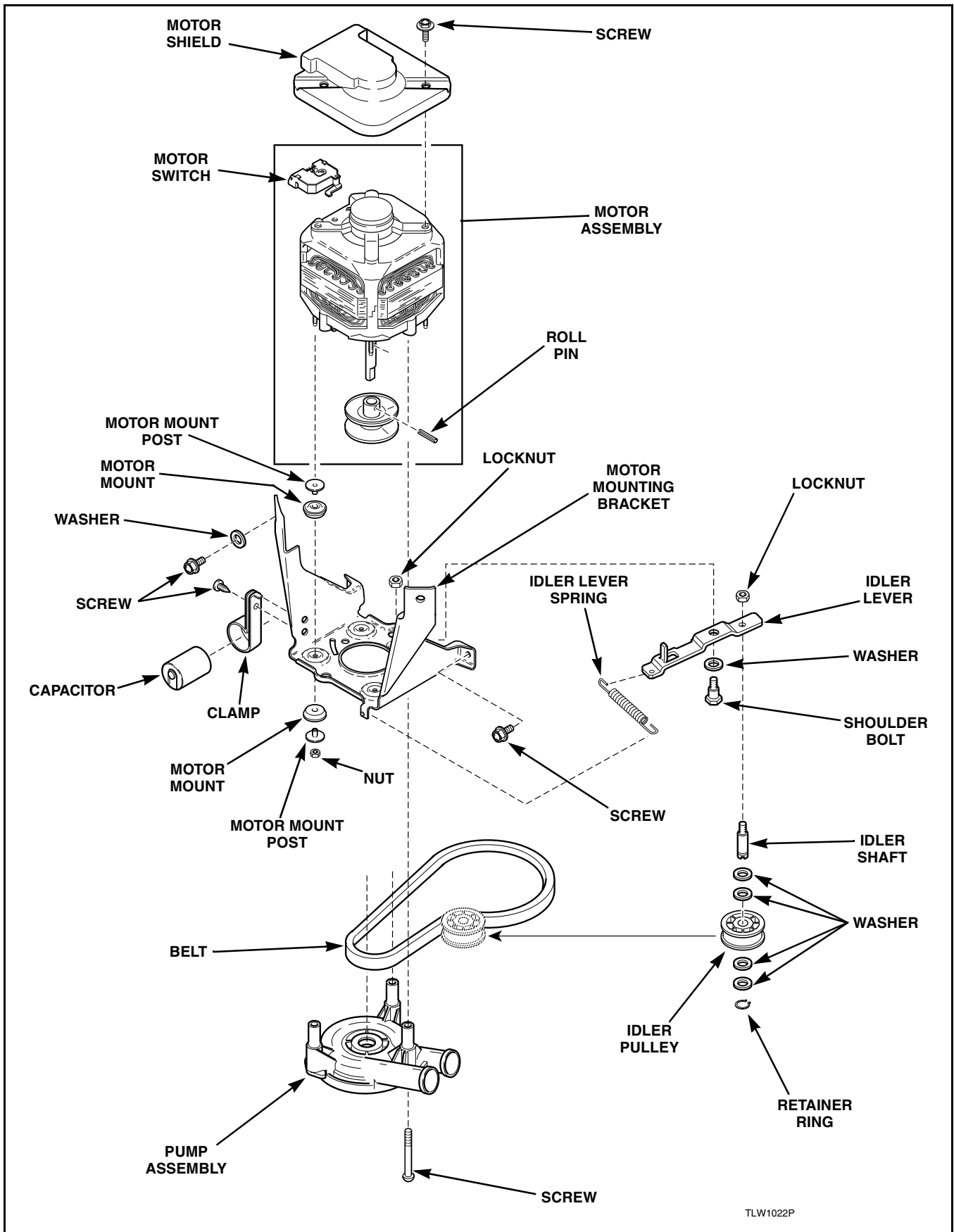

TLW1022P

Figure 42



WARNING

To reduce the risk of electric shock, fire, explosion, serious injury or death:

- Disconnect electric power to the washer before servicing.
- Never start the washer with any guards/panels removed.
- Whenever ground wires are removed during servicing, these ground wires must be reconnected to ensure that the washer is properly grounded.

W003

31. MOTOR DRIVE PULLEY

- a. Remove two screws from bottom edge of front panel. Refer to *Figure 37*.
- b. Pull bottom of panel away from washer until hold down clips (located on top flange of panel) disengage from slots in cabinet top.

IMPORTANT: There will always be some water that will remain in outer tub, therefore, before removing hoses from pump, hoses must be pinched off or drained to prevent water spillage.

- c. Loosen hose clamps and remove hoses from pump assembly. Refer to *Figure 40*.
- d. Unhook idler spring from idler lever. Refer to *Figure 40*.

IMPORTANT: Use care when removing idler spring. If idler spring is overstretched, washer operation will be affected.

- e. Reach in and around right side of motor and run belt off right side of large drive pulley. Refer to *Figure 40*.
- f. Disconnect wire harness from motor switch by pressing down on locking tab on top of connection block and at the same time pull connection block away from motor switch. Refer to *Figure 40*.
- g. Remove four screws holding motor mounting bracket to lower flange of outer tub and to weldment assembly. Refer to *Figure 40*. Then remove complete assembly out of washer.
- h. Lay motor assembly on its side.

NOTE: To remove pulley, support motor shaft (to prevent bending shaft) and drive out pulley roll pin (through Serial No. 001113645). Refer to *Figure 42*.

32. MOTOR SWITCH

- a. Remove two screws from bottom edge of front panel. Refer to *Figure 37*.
- b. Pull bottom of panel away from washer until hold down clips (located on top flange of panel) disengage from slots in cabinet top.
- c. Remove motor and mounting bracket. Refer to *Paragraph 30*.
- d. Remove two screws holding motor shield to motor. Refer to *Figure 43* and remove shield.
- e. Disconnect wire harness from motor switch by pressing down on locking tab on top of connection block and at the same time pull connection block away from motor switch. Refer to *Figure 43*.

IMPORTANT: To avoid an open circuit, DO NOT pull on terminal block wires when removing block from motor switch as this could damage wires or connection crimpings. Before attaching wire harness connection block to motor switch, make sure all male terminals on motor switch are straight and are capable of accepting terminals from wire harness connection block.

- f. Remove screw holding motor switch to motor. Refer to *Figure 43*. Then remove switch.
- g. Disconnect internal motor leads from motor switch terminals.

NOTE: Refer to Wiring Schematics, SECTION 9 for rewiring internal motor switch wires.



WARNING

To reduce the risk of electric shock, fire, explosion, serious injury or death:

- Disconnect electric power to the washer before servicing.
- Never start the washer with any guards/panels removed.
- Whenever ground wires are removed during servicing, these ground wires must be reconnected to ensure that the washer is properly grounded.

W003

33. IDLER LEVER AND PULLEY

- a. Remove two screws from bottom edge of front panel. Refer to *Figure 37*.
- b. Pull bottom of panel away from washer until hold down clips (located on top flange of panel) disengage from slots in cabinet top.

IMPORTANT: There will always be some water that will remain in outer tub, therefore, before removing hoses from pump, hoses must be pinched off or drained to prevent water spillage.

- c. Loosen hose clamps and remove hoses from pump assembly. Refer to *Figure 43*.
- d. Unhook idler spring from idler lever. Refer to *Figure 43*.

IMPORTANT: Use care when removing idler spring. If idler spring is overstretched, washer operation will be affected.

- e. Reach in and around right side of motor and run belt off right side of large drive pulley. Refer to *Figure 43*.

- f. Disconnect wire harness from motor switch by pressing down on locking tab on top of connection block and at the same time pull connection block away from motor switch. Refer to *Figure 43*.
- g. Remove four screws holding motor mounting bracket to lower flange of outer tub and to weldment assembly. Refer to *Figure 43*. Then remove complete assembly out of washer.

NOTE: For ease of idler lever removal, remove pump assembly from motor, then remove motor from mounting bracket.

- h. Remove nut, washer and bolt holding idler lever and pulley to motor mounting bracket. Refer to *Figure 42*.

NOTE: Refer to *Figure 42* for idler lever and pulley assembly sequence.

- i. Apply a light film of No. 03200 Lubricant to area of idler lever that makes contact with motor mounting bracket.

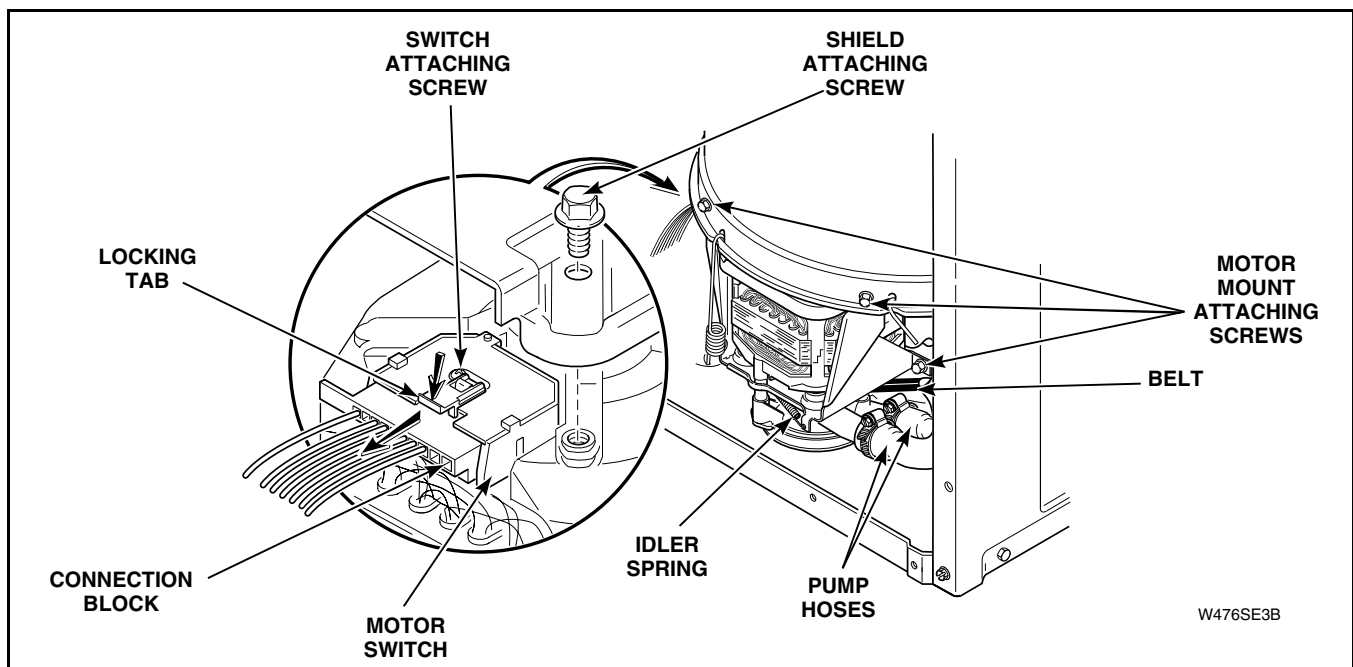

Figure 43



WARNING

To reduce the risk of electric shock, fire, explosion, serious injury or death:

- Disconnect electric power to the washer before servicing.
- Never start the washer with any guards/panels removed.
- Whenever ground wires are removed during servicing, these ground wires must be reconnected to ensure that the washer is properly grounded.

W003

34. MIXING VALVE ASSEMBLY

- a. Remove two screws from bottom edge of front panel. Refer to *Figure 37*.
- b. Pull bottom of panel away from washer until hold down clips (located on top flange of panel) disengage from slots in cabinet top.
- c. **METERED MODELS:**
 - (1) Unlock and remove meter case service door.
 - (2) Remove timer bracket cap screw. Refer to *Figure 9*.
 - (3) Slide timer and bracket toward rear of meter case to disengage bracket from shoulder screw. Lift timer and bracket out of meter case through service door opening as far as wires will permit.
 - (4) Remove shoulder screw from inside meter case.
 - (5) Remove two cabinet top hold down screws. Refer to *Figure 37*.
 - (6) Remove security bolt (if present) from left rear corner of cabinet top.

NOTE: When lowering cabinet top into position or reinstalling cabinet top, pivot outer tub forward far enough to prevent damaging (bending) loading door switch lever.

- d. Tape loading door closed and lift cabinet top to a vertical position by hinging it on the rear hinges.

NOTE: Cabinet top is self supporting, however, a small chain may be used for additional support. Refer to *Figure 38*.

- e. Remove screw(s) holding mixing valve to mounting bracket at rear of washer cabinet. Refer to *Figure 44*.

NOTE: When installing mixing valve, tab on bottom flange must be placed in positioning hole in mounting bracket.

- f. Pull mixing valve out toward front of washer far enough to permit disconnecting water inlet and fill hoses from mixing valve. Refer to *Figure 44*.
- g. Remove wires and quick disconnect blocks from mixing valve solenoid terminals. Refer to *Figure 44*.

NOTE: Refer to appropriate wiring diagram when rewiring solenoid.

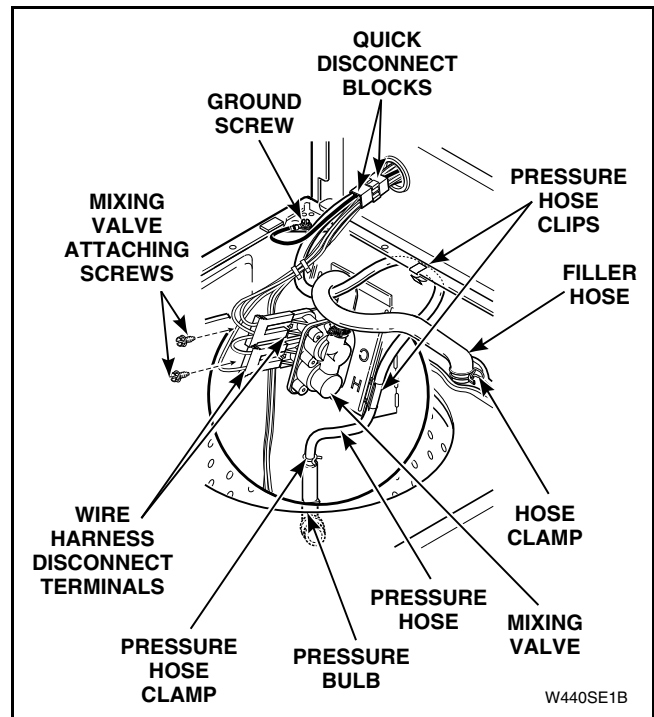

Figure 44



WARNING

To reduce the risk of electric shock, fire, explosion, serious injury or death:

- Disconnect electric power to the washer before servicing.
- Never start the washer with any guards/panels removed.
- Whenever ground wires are removed during servicing, these ground wires must be reconnected to ensure that the washer is properly grounded.

W003

35. DOOR SWITCH

- a. Remove two screws from bottom edge of front panel. Refer to *Figure 37*.
- b. Pull bottom of panel away from washer until hold down clips (located on top flange of panel) disengage from slots in cabinet top.
- c. **METERED MODELS:**
 - (1) Unlock and remove meter case service door.
 - (2) Remove timer bracket cap screw. Refer to *Figure 9*.
 - (3) Slide timer and bracket toward rear of meter case to disengage bracket from shoulder screw. Lift timer and bracket out of meter case through service door opening as far as wires will permit.
 - (4) Remove shoulder screw from inside meter case.
 - (5) Remove two cabinet top hold down screws. Refer to *Figure 37*.
 - (6) Remove security bolt (if present) from left rear corner of cabinet top.

NOTE: When lowering cabinet top into position or reinstalling cabinet top, pivot outer tub forward far enough to prevent damaging (bending) loading door switch lever.

- d. Tape loading door closed and lift cabinet top to a vertical position by hinging it on the rear hinges.

NOTE: Cabinet top is self supporting, however, a small chain may be used for additional support. Refer to *Figure 38*.

- e. Remove screw holding door switch assembly to underside of cabinet top. Refer to *Figure 45*.
- f. Disconnect wires from door switch.

NOTE: Refer to appropriate wiring diagram when rewiring switch.

- g. Remove two screws holding switch to switch holder. Refer to *Figure 45*.
- h. Remove switch from switch holder.

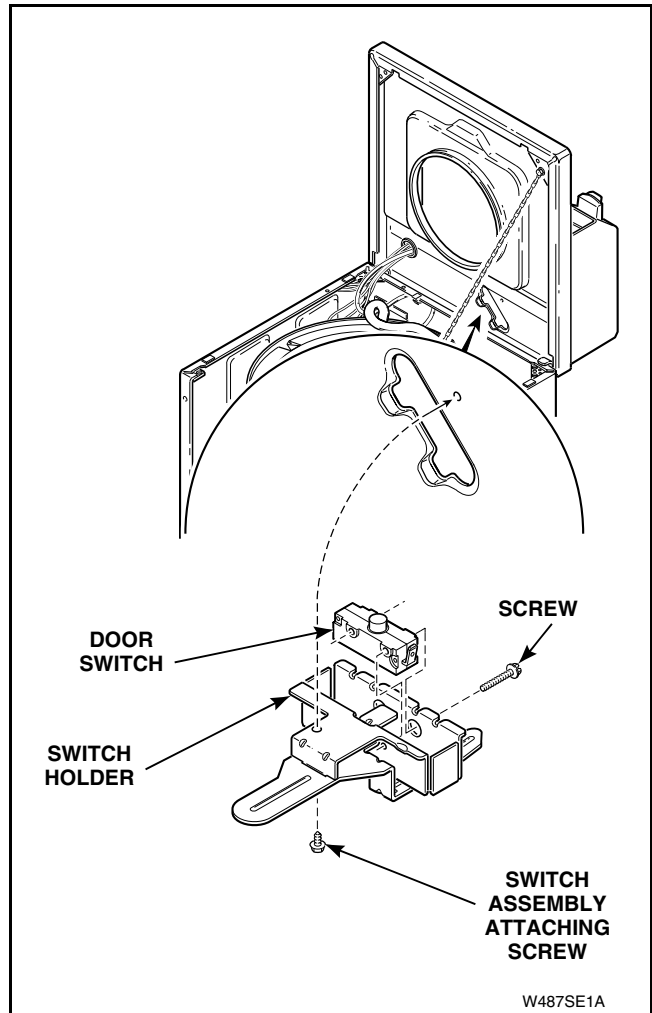

Figure 45



WARNING

To reduce the risk of electric shock, fire, explosion, serious injury or death:

- Disconnect electric power to the washer before servicing.
- Never start the washer with any guards/panels removed.
- Whenever ground wires are removed during servicing, these ground wires must be reconnected to ensure that the washer is properly grounded.

W003

36. WASHTUB AND BALANCE RING

- a. Open loading door.
- b. Remove agitator by placing two agitator hooks, No. 254P4P, under bottom edge of agitator. Refer to *Figure 29*.

IMPORTANT: Hooks should be positioned 180 degrees from each other, and must be placed under agitator vane for greater stability. If hooks are placed between vane area, agitator damage may occur.

- c. Using a rocking motion (back and forth) carefully lift agitator off drive bell.
- d. Remove two screws from bottom edge of front panel. Refer to *Figure 37*.
- e. Pull bottom of panel away from washer until hold down clips (located on top flange of panel) disengage from slots in cabinet top.

f. METERED MODELS:

- (1) Unlock and remove meter case service door.
- (2) Remove timer bracket cap screw. Refer to *Figure 9*.
- (3) Slide timer and bracket toward rear of meter case to disengage bracket from shoulder screw. Lift timer and bracket out of meter case through service door opening as far as wires will permit.
- (4) Remove shoulder screw from inside meter case.
- (5) Remove two cabinet top hold down screws. Refer to *Figure 37*.
- (6) Remove security bolt (if present) from left rear corner of cabinet top.

NOTE: When lowering cabinet top into position or reinstalling cabinet top, pivot outer tub forward far enough to prevent damaging (bending) loading door switch lever.

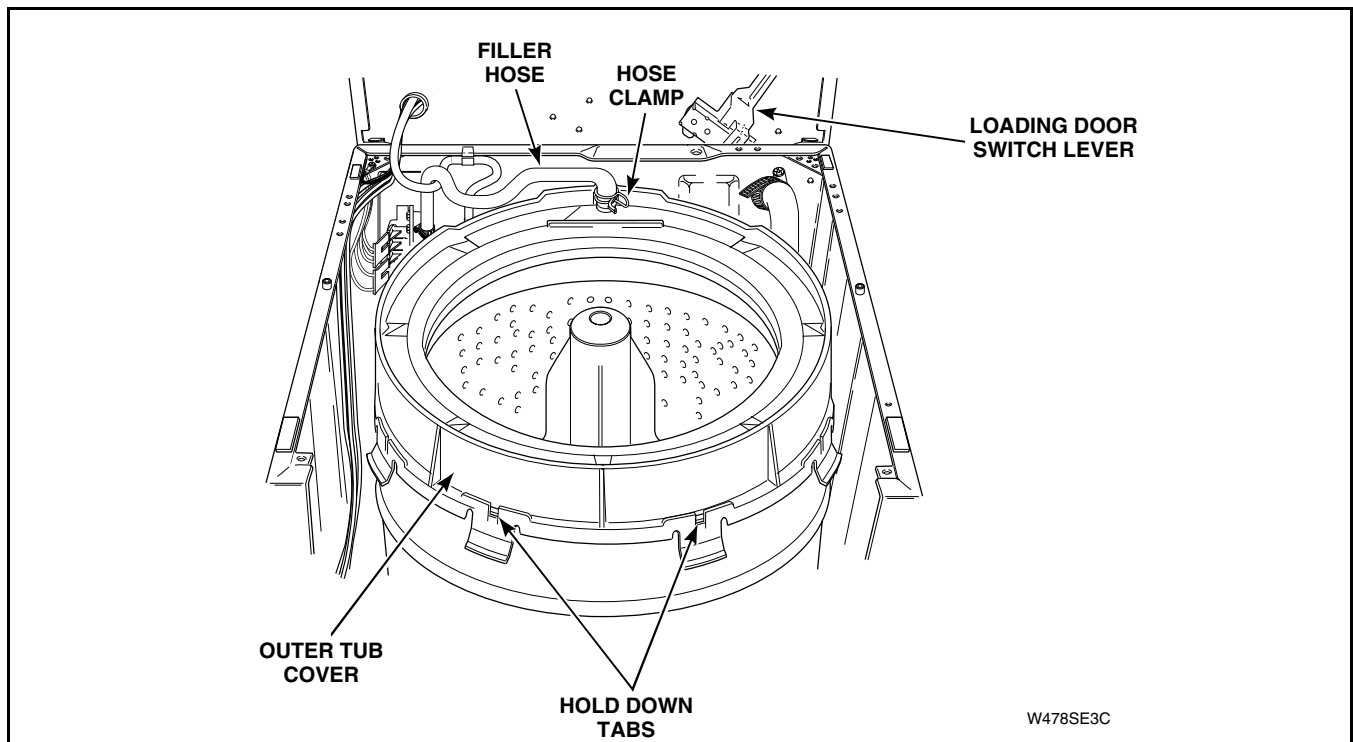

Figure 46



WARNING

To reduce the risk of electric shock, fire, explosion, serious injury or death:

- Disconnect electric power to the washer before servicing.
- Never start the washer with any guards/panels removed.
- Whenever ground wires are removed during servicing, these ground wires must be reconnected to ensure that the washer is properly grounded.

W003

- g. If area or space permits, tape loading door closed and lift cabinet top to a vertical position by hinging it on the rear hinges. Refer to *Figure 38*.

NOTE: Cabinet top is self supporting, however, a small chain may be used for additional support. Refer to *Figure 38*.

- h. Loosen hose clamp and remove filler hose from outer tub cover. Refer to *Figure 46*.

NOTE: When installing filler hose, white line on hose must point toward front of washer. Refer to *Figure 46*.

- i. There are eight tub cover hold-down tabs which snap over outer tub flange. Place your fingers under the flap of the hold-down tab of the tub cover. Pull out on flap and at the same time lift upward on cover to unsnap hold-down tabs from outer tub flange. One by one, disengage each of the eight hold-down tabs from outer tub flange and remove cover.

IMPORTANT: When installing outer tub cover, always use a new cover gasket.

NOTE: Clean and remove any foreign material in gasket groove of outer tub cover and outer tub flange.

- j. Starting at positioning pin, lay gasket into gasket groove of tub cover. Refer to *Figure 47*.
- k. Using your fingers, press gasket down into gasket groove of tub cover. Avoid pressing gasket past ends of hold-down tabs.

IMPORTANT: Care must be taken not to twist or bunch gasket in any one area to avoid leaks after assembly.

- l. Install gasket past ends of hold-down tabs to bottom of gasket groove using semi-circled end of tool Part No. 273P4. Refer to *Figure 47*.

NOTE: Tub cover gasket tool, Part No. 273P4, is designed to spread open hold-down tabs to prevent tearing of gasket during installation.

- m. With tub cover tilted at approximately a 45 degree angle, insert the positioning pin into notch on outer tub flange.
- n. Lower cover and push down firmly on top of hold-down tabs next to positioning pin until tabs snap over edge of outer tub flange.
- o. Cross over to opposite side of tub cover and push down firmly on top of hold-down tabs until tabs snap over edge of outer tub flange. Continue with this criss-cross pattern, until tub cover is fully seated. Visually check each tab area again to ensure cover is seated.

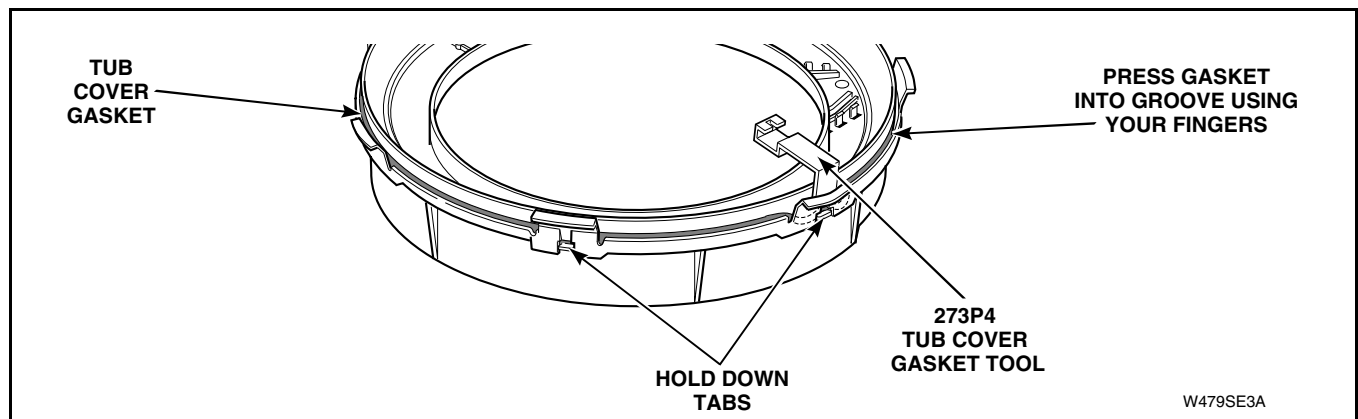

Figure 47

W479SE3A

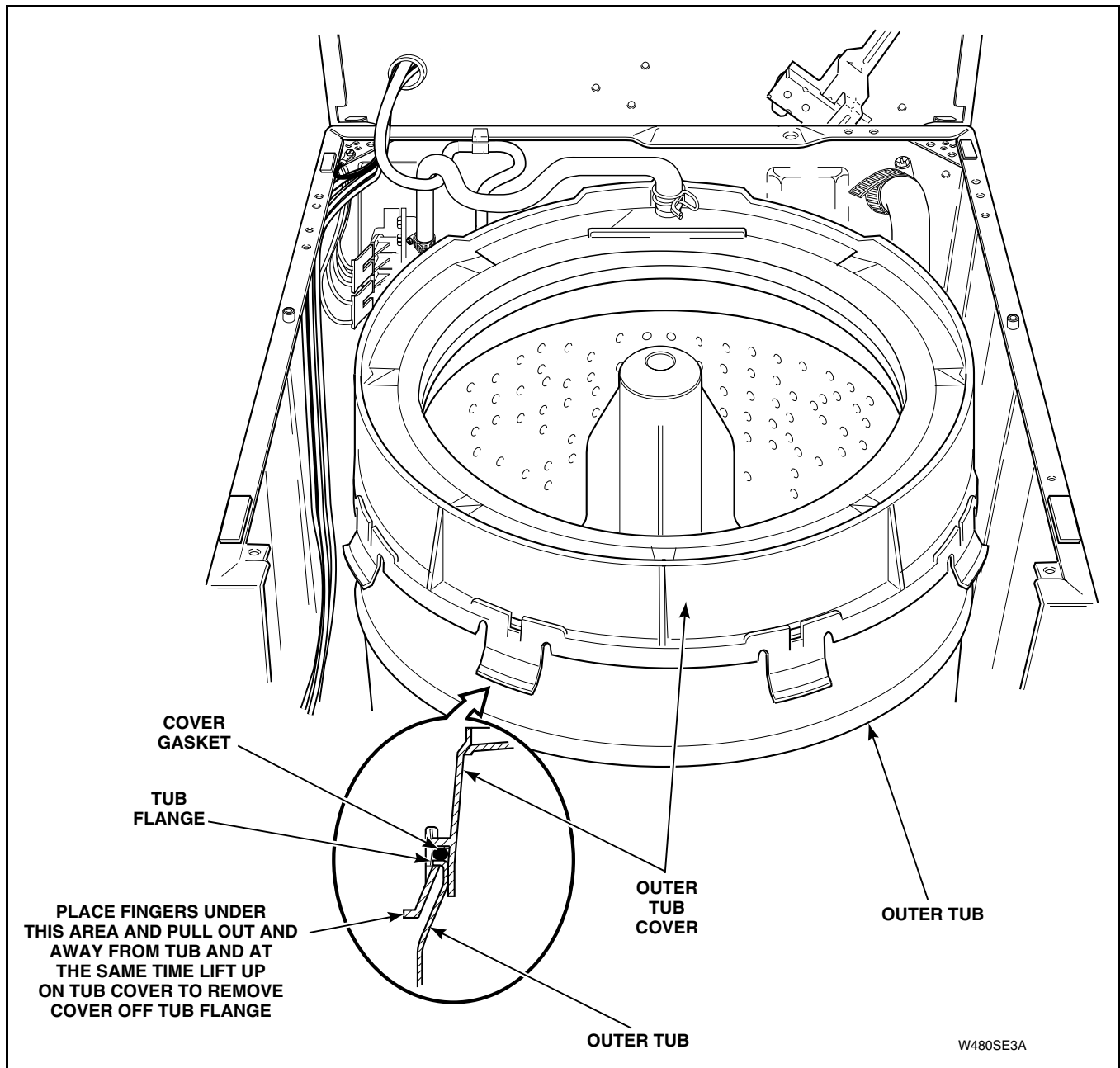

Figure 48



WARNING

To reduce the risk of electric shock, fire, explosion, serious injury or death:

- Disconnect electric power to the washer before servicing.
- Never start the washer with any guards/panels removed.
- Whenever ground wires are removed during servicing, these ground wires must be reconnected to ensure that the washer is properly grounded.

W003

- p. Remove screws and washers holding washtub to hub. Refer to *Figure 45*.

IMPORTANT: Porcelain Washtub Models — Use care when tightening screws to avoid chipping porcelain on washtub.

- q. Lift washtub and balance ring out of outer tub.

IMPORTANT: When removing washtub and balance ring, grasp top flange of washtub and remove from outer tub.

NOTE: When installing washtub, make sure all traces of old gasket are removed from bottom of washtub. Always use a new gasket between washtub and hub.

TO REMOVE BALANCE RING FROM WASHTUB

- r. Place blade of a small screwdriver into slots between balance ring and washtub. Refer to *Figure 49*.
- s. Carefully pry pins of balance ring out of holes in washtub. Refer to *Figure 49*.

NOTE: As you are prying out pins, lift up on balance ring.

- t. Pry at least 7 of the 8 pins out of washtub holes before balance ring can be removed.

TO INSTALL BALANCE RING IN WASHTUB

Place balance ring on top of washtub, making sure balance ring pins line up with holes in washtub. Then carefully push balance ring down into washtub until all pins snap into their respective holes.

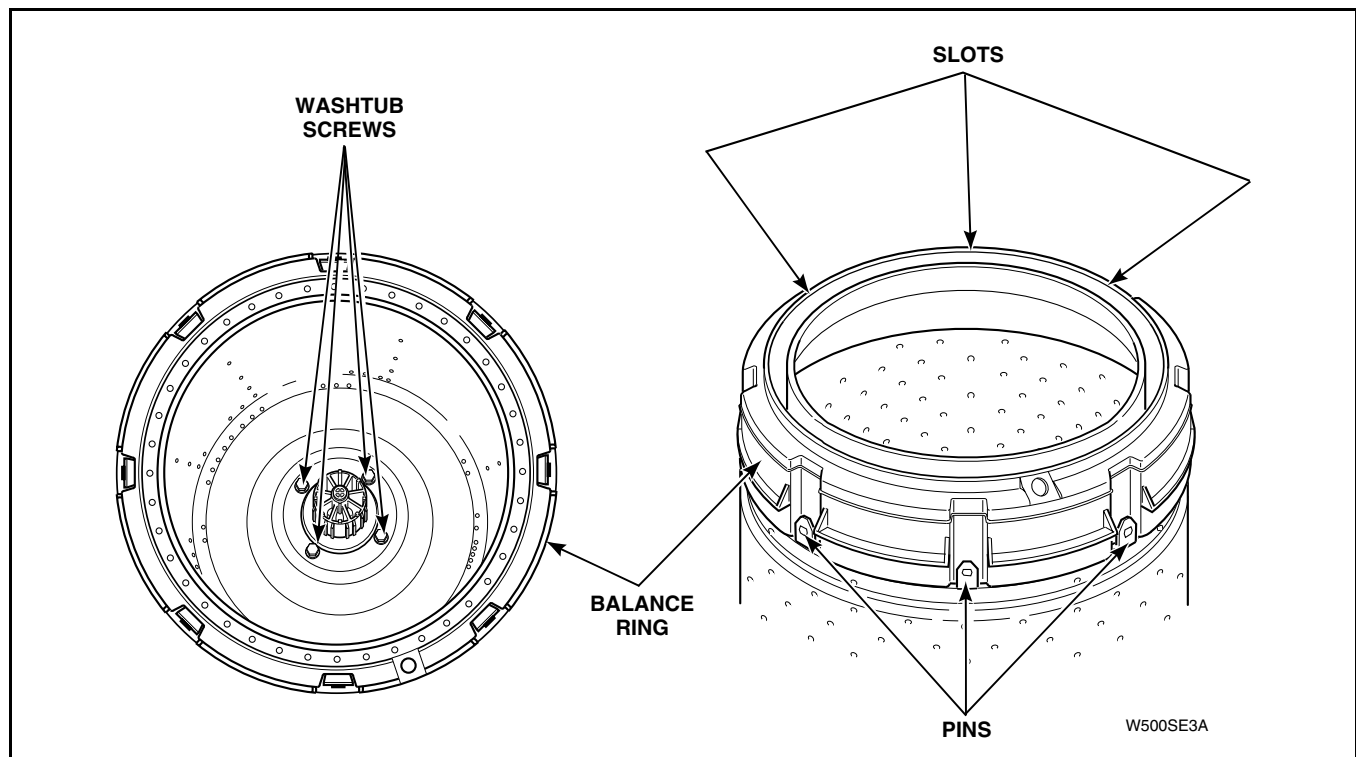

Figure 49



WARNING

To reduce the risk of electric shock, fire, explosion, serious injury or death:

- Disconnect electric power to the washer before servicing.
- Never start the washer with any guards/panels removed.
- Whenever ground wires are removed during servicing, these ground wires must be reconnected to ensure that the washer is properly grounded.

W003

37. HUB AND SEAL KIT ASSEMBLY

- a. Open loading door.
- b. Remove agitator by placing two agitator hooks, No. 254P4P, under bottom edge of agitator. Refer to *Figure 29*.

IMPORTANT: Hooks should be positioned 180 degrees from each other, and must be placed under agitator vanes for greater stability. If hooks are placed between vane area, damage to agitator may occur.

- c. Using a rocking motion (back and forth) carefully lift agitator off drive bell.
- d. Remove two screws from bottom edge of front panel. Refer to *Figure 37*.
- e. Pull bottom of panel away from washer until hold down clips (located on top flange of panel) disengage from slots in cabinet top.
- f. **METERED MODELS:**
 - (1) Unlock and remove meter case service door.
 - (2) Remove timer bracket cap screw. Refer to *Figure 9*.
 - (3) Slide timer and bracket toward rear of meter case to disengage bracket from shoulder screw. Lift timer and bracket out of meter case through service door opening as far as wires will permit.
 - (4) Remove shoulder screw from inside meter case.
 - (5) Remove two cabinet top hold down screws. Refer to *Figure 37*.
 - (6) Remove security bolt (if present) from left rear corner of cabinet top.

NOTE: When lowering cabinet top into position or reinstalling cabinet top, pivot outer tub forward far enough to prevent damaging (bending) loading door switch lever.

- g. If area or space permits, tape loading door closed and lift cabinet top to a vertical position by hinging it on the rear hinges.

NOTE: Cabinet top is self supporting, however, a small chain may be used for additional support. Refer to *Figure 38*.

- h. Loosen hose clamp and remove filler hose from outer tub cover. Refer to *Figure 46*.

NOTE: When installing filler hose, white line on hose must point toward front of washer. Refer to *Figure 46*.

TUB COVER AND GASKET

- (1) There are eight tub cover hold-down tabs which snap over the outer tub flange. Place your fingers under the flap of the hold-down tab of the tub cover. Pull out on flap and at the same time lift upward on cover to unsnap hold-down tabs from outer tub flange. One by one, disengage each of the eight hold-down tabs from outer tub flange and remove cover.
- (2) Lift cover off outer tub and set beside washer cabinet.

IMPORTANT: When installing outer tub cover, always use a new cover gasket.

NOTE: Clean and remove any foreign material in gasket groove of outer tub cover and outer tub flange.

- (3) Starting at the positioning pin located at the bleach funnel area, lay gasket into gasket groove of tub cover. Refer to *Figure 47*.
- (4) Using your fingers, press gasket down into gasket groove of tub cover. Avoid pressing gasket past ends of hold-down tabs.

IMPORTANT: Care must be taken not to twist or bunch gasket in any one area to avoid leaks after assembly.

- (5) Install gasket past ends of hold-down tabs to bottom of gasket groove using semi-curved end of tub cover gasket tool Part No. 273P4. Refer to *Figure 47*.

NOTE: Tub cover gasket tool, Part No. 273P4, is designed to spread open hold-down tabs to prevent tearing of gasket during installation.

- (6) With tub cover tilted at approximately 45 degree angle, insert the positioning pin into notch on outer tub flange.



WARNING

To reduce the risk of electric shock, fire, explosion, serious injury or death:

- Disconnect electric power to the washer before servicing.
- Never start the washer with any guards/panels removed.
- Whenever ground wires are removed during servicing, these ground wires must be reconnected to ensure that the washer is properly grounded.

W003

- (7) Lower cover and push down firmly on top of hold-down tabs next to positioning pin until tabs snap over edge of outer tub flange.
- (8) Cross over to opposite side of tub cover and push down firmly on top of hold-down tabs until tabs snap over edge of outer tub flange. Continue with this criss-cross pattern, until tub cover is fully seated. Visually check each tab area again to ensure cover is seated.
- i. Remove screws holding washtub to hub. Refer to *Figure 49*. Then lift washtub (with balance ring attached) out of outer tub.

IMPORTANT: When removing washtub, grasp top flange of washtub and remove from outer tub.

NOTE: When installing washtub, make sure gasket is between underside of washtub and hub.

TO REMOVE AGITATOR DRIVE BELL

- a. Remove plug, screw (and "O" ring if present) from top side of drive bell.

NOTE: No 294P4 Drive Bell Tool may be required to remove drive bell from transmission shaft, if not, proceed to step i.

- b. Back bolt out of tool approximately three quarters of the way. Refer to *Figure 30*.
- c. Place tool over bell, making sure indent on jaw lines up with the wide slots on bell. Refer to *Figure 30*.
- d. Screw bolt down through hole in top of bell until bolt bottoms out in hole in transmission shaft.
- e. Place lip of each jaw under bottom edge of drive bell, making sure indent on jaw lines up with wide slots on bell. Then tighten two wing nuts to hold jaws firmly against drive bell. Refer to *Figure 31*.
- f. Use an adjustable wrench and turn large nut on tool **COUNTERCLOCKWISE** to pull drive bell from transmission shaft. Refer to *Figure 32*.

IMPORTANT: If large nut is turned clockwise when pulling drive bell, you will twist off quarter inch bolt.

- g. Turn quarter inch bolt out of transmission shaft, and remove tool and drive bell from washer.
- h. Loosen two wing nuts and remove drive bell from tool.
- i. Remove old seal from hub by placing a flat blade screwdriver between bottom edge of seal and hub using washtub bolts as a pry area to pop off lower seal bead. Then grasp seal and pull straight up freeing the upper seal bead.
- j. Remove large hex nut using a No. 306P4 Hex Wrench. Refer to *Figure 50*.
- k. Remove spline insert from transmission tube.

IMPORTANT: Use a new spline insert each time hex nut is removed. **DO NOT** reuse old insert because hex nut may loosen during washer operation.

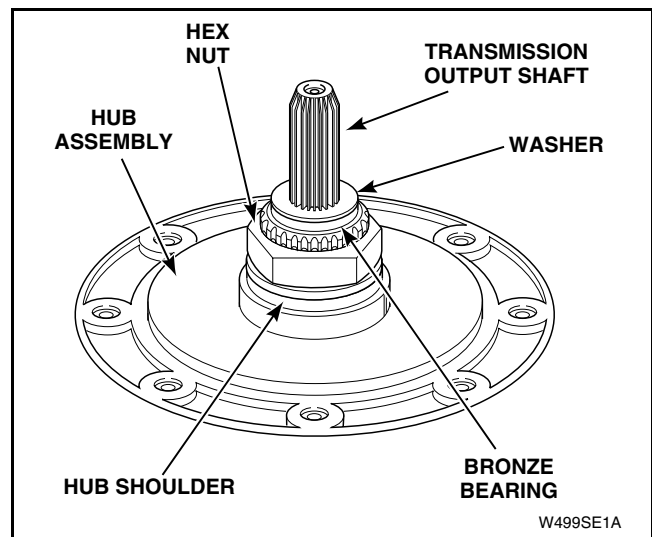

Figure 50

- l. Remove hub from splines on transmission tube.

NOTE: It may be necessary to use a gear puller to remove hub.

- m. Remove old water seal from outer tub.

IMPORTANT: Use care when removing old seal so as not to damage tub flange or porcelain.



WARNING

To reduce the risk of electric shock, fire, explosion, serious injury or death:

- Disconnect electric power to the washer before servicing.
- Never start the washer with any guards/panels removed.
- Whenever ground wires are removed during servicing, these ground wires must be reconnected to ensure that the washer is properly grounded.

W003

INSTALLING NO. 646P3 HUB AND SEAL KIT

- a. Thoroughly clean all foreign material from inner surface of outer tub flange.

IMPORTANT: All foreign material must be removed from inner surface of outer tub flange before installing No. 646P3 Hub and Seal Kit.

- b. Apply a small amount of No. 27615P Sealant (3M800) around outer surface of tub flange. Refer to *Figure 51*. Obtain sealant from local parts distributor.
- c. Apply a light film of nonstaining petroleum jelly (such as Vaseline®) to bronze portion of water seal and to outer surface of stainless steel sleeve. Refer to *Figure 52*.

IMPORTANT: DO NOT over lubricate!

- d. Insert stainless steel sleeve into water seal from bottom of water seal, Refer to *Figure 52*, until stainless steel sleeve is flush with bronze portion of water seal.
- e. Leaving garter spring on water seal, place new water seal over outer tub flange (with seal lip on outside of tub flange). Then press seal into tub flange opening using moderate finger pressure.
- f. Carefully apply a small amount of No. 27615P Sealant (3M800) around outer edge of water seal and tub (area located just below garter spring). Refer to *Figure 52*. Obtain sealant from local parts distributor.

IMPORTANT: DO NOT allow sealant to contact sealing surface of water seal because it will cause a water leak.

- g. Lubricate inner splines of new hub assembly (supplied in kit) with No. 27604P Anti-Seeze Compound.
- h. Carefully place new hub assembly on splined transmission tube.

IMPORTANT: Firmly push hub assembly down against outer tub seal and hold in this position during the next three steps.

- i. While holding down hub assembly, place new spline insert (with fingers pointing upward) over transmission tube until it bottoms out on hub assembly.
- j. Place large hex nut over transmission tube (with larger inside bevel toward spline insert) then finger tighten large hex nut.
- k. Torque large hex nut between 40 to 70 foot-pounds (5.56 to 13.21 Kgm).

NOTE: If torque wrench is not available, place No. 306P4 Hex Wrench over large hex nut then tap hex wrench with a hammer until hub assembly turns or until large hex nut will no longer tighten.

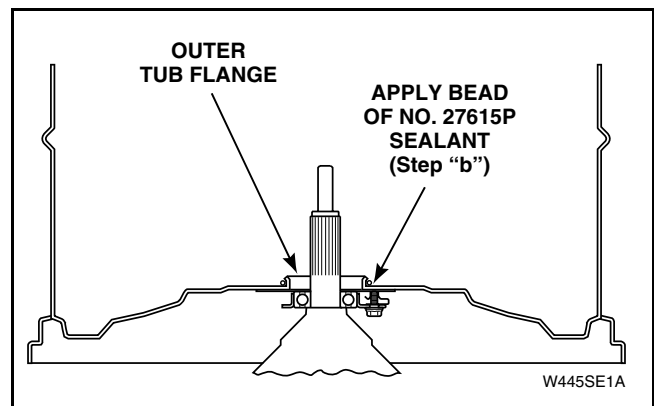

Figure 51



WARNING

To reduce the risk of electric shock, fire, explosion, serious injury or death:

- Disconnect electric power to the washer before servicing.
- Never start the washer with any guards/panels removed.
- Whenever ground wires are removed during servicing, these ground wires must be reconnected to ensure that the washer is properly grounded.

W003

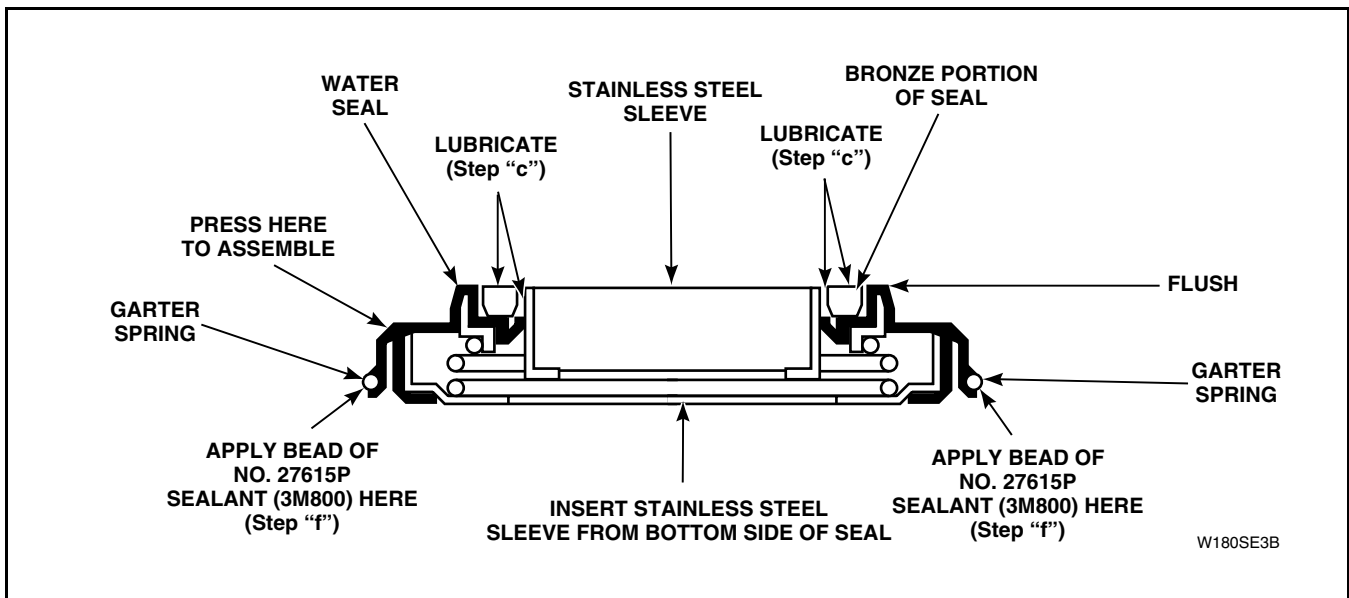

Figure 52

- I. To install No. 39122 Gasket, follow these steps:
 - (1) Thoroughly clean all foreign material from seal surface area of hub and bronze bearing.
 - (2) Apply a small amount of nonstaining petroleum jelly (such as Vaseline®) to both surfaces where gasket will contact hub assembly and bottom of washtub.
 - (3) Carefully place No. 39122 Gasket (supplied in kit) on hub assembly.

NOTE: Ensure holes in gasket are aligned with holes in hub assembly and all traces of original washtub gasket are removed from bottom of washtub.

- m. Grasp top flange of washtub and carefully lower washtub down onto gasket and hub assembly.

IMPORTANT: Before setting washtub into place, make sure holes in hub assembly are aligned with holes in gasket.

- n. Secure washtub to hub assembly, using cap screws and gaskets from 27202P Screw and Gasket Kit (supplied in kit).

NOTE: Gaskets are used on models equipped with a porcelain washtub.

IMPORTANT: Porcelain Washtub Models — Use care when tightening cap screws to avoid chipping or damaging porcelain finish.

- o. Install No. 38359 Tub Cover Gasket (supplied in kit) into outer tub cover. Refer to *Paragraph 36*.

IMPORTANT: When installing outer tub cover always use a new tub cover gasket.

- p. Reassemble washtub, *Paragraph 36*.
- q. Install seal, drive bell and agitator following the instructions supplied in No. 39508P Drive Bell and Seal Kit.
- r. Reinstall cabinet top and front panel.
- s. Close loading door, set washer timer to final spin, start washer and allow empty washtub to spin for 30 seconds.



WARNING

To reduce the risk of electric shock, fire, explosion, serious injury or death:

- **Disconnect electric power to the washer before servicing.**
- **Never start the washer with any guards/panels removed.**
- **Whenever ground wires are removed during servicing, these ground wires must be reconnected to ensure that the washer is properly grounded.**

W003

IMPORTANT: Setting washer to spin allows petroleum jelly (applied to bronze portion of water seal) a chance to cover seal surface before water is added to washer.

38. OUTER TUB

- a. Open loading door.
- b. Remove agitator by placing two agitator hooks, No. 254P4P, under bottom edge of agitator. Refer to *Figure 29*.

IMPORTANT: Hooks should be positioned 180 degrees from each other, and must be placed under agitator vane for greater stability. If hooks are placed between vane area, agitator damage may occur.

- c. Using a rocking motion (back and forth) carefully lift agitator off drive bell.
- d. Remove two screws from bottom edge of front panel. Refer to *Figure 37*.
- e. Pull bottom of panel away from washer until hold down clips (located on top flange of panel) disengage from slots in cabinet top.
- f. **METERED MODELS:**
 - (1) Unlock and remove meter case service door.
 - (2) Remove timer bracket cap screw. Refer to *Figure 9*.
 - (3) Slide timer and bracket toward rear of meter case to disengage bracket from shoulder screw. Lift timer and bracket out of meter case through service door opening as far as wires will permit.
 - (4) Remove shoulder screw from inside meter case.
 - (5) Remove two cabinet top hold down screws.
 - (6) Remove security bolt (if present) from left rear corner of cabinet top.

NOTE: When lowering cabinet top into position or reinstalling cabinet top, pivot outer tub forward far enough to prevent damaging (bending) loading door switch lever.

- g. If area or space permits, tape loading door closed and lift cabinet top to a vertical position by hinging it on the rear hinges.

NOTE: Cabinet top is self supporting, however, a small chain may be used for additional support. Refer to *Figure 38*.

- h. Loosen hose clamp, and disconnect filler hose from outer tub cover. Refer to *Figure 46*.

NOTE: When reinstalling filler hose, white line on hose must point toward front of washer. Refer to *Figure 46*.

TUB COVER AND GASKET

- (1) There are eight tub cover hold-down tabs which snap over the outer tub flange. Place your fingers under the flaps of the hold-down tab of the tub cover. Pull out on the flap and at the same time lift upward on cover to unsnap hold-down tabs from outer tub flange. One by one, disengage each of the eight hold-down tabs from outer tub flange and remove cover.
- (2) Remove cover from outer tub and remove old gasket from tub cover.

NOTE: When installing outer tub cover, always use a new cover gasket.

NOTE: Clean and remove any foreign material in gasket groove of outer tub cover and outer tub flange.

- (3) Starting at positioning pin located at the bleach funnel area, lay gasket into gasket groove of tub cover. Refer to *Figure 47*.
- (4) Using your fingers, press gasket down into gasket groove of tub cover. Avoid pressing gasket past ends of hold-down tabs.

IMPORTANT: Care must be taken not to twist or bunch gasket in any one area to avoid leaks after assembly.



WARNING

To reduce the risk of electric shock, fire, explosion, serious injury or death:

- **Disconnect electric power to the washer before servicing.**
- **Never start the washer with any guards/panels removed.**
- **Whenever ground wires are removed during servicing, these ground wires must be reconnected to ensure that the washer is properly grounded.**

W003

- (5) Early models – Install gasket past ends of hold-down tabs to bottom of gasket groove using semi-curved end of tub cover gasket tool Part No. 273P4.

NOTE: Tub cover gasket tool, Part No. 273P4, is designed to spread open hold-down tabs to prevent tearing of gasket during installation.

- (6) With tub cover tilted at approximately a 45 degree angle, insert the positioning pin into notch on outer tub flange.
- (7) Lower cover and push down firmly on top of hold-down tabs next to positioning pin until tabs snap over edge of outer tub flange.
- (8) Cross over to opposite side of tub cover and push down firmly on top of hold-down tabs until tabs snap over edge of outer tub flange. Continue with this criss-cross pattern, until tub cover is fully seated. Visually check each tab area again to ensure cover is seated.
Refer to *Figure 48*.
- i. Remove screws and gaskets holding washtub to hub. Refer to *Figure 49*.

IMPORTANT: Porcelain Washtub Models — Use care when tightening cap screws to avoid chipping porcelain on washtub.

- j. Lift washtub (with balance ring attached) out of outer tub.

IMPORTANT: When removing washtub and balance ring, grasp top flange of washtub and remove from outer tub.

- k. Remove agitator drive bell, *Paragraph 27*.
- l. Remove large hex nut using No. 306P4 Hex Wrench. Then remove spline insert from transmission tube.

IMPORTANT: Use a new spline insert each time the hex nut is removed. DO NOT reuse the old insert as hex nut may loosen during the washer operation.

- m. Remove hub from splines on transmission tube.

NOTE: It may be necessary to use a gear puller to remove hub.

- n. Remove old water seal from outer tub.

IMPORTANT: Use care when removing old seal so as not to damage tub flange or porcelain.

NOTE: When reinstalling or replacing outer tub, always install a new No. 646P3 Hub and Seal Kit. Refer to *Paragraph 37*.

- o. Reach in through front of motor mounting bracket and move idler lever to left to release tension on belt.

IMPORTANT: Use care when releasing idler lever tension. If idler lever spring is overstretched, washer operation will be affected.

- p. While holding idler lever, reach in and around right side of motor and run belt off right side of pulley.
- q. Using No. 289P4 Spring Hook Tool, unhook six module springs from lower edge of outer tub. Refer to *Figure 53*.



WARNING

To reduce the risk of electric shock, fire, explosion, serious injury or death:

- Disconnect electric power to the washer before servicing.
- Never start the washer with any guards/panels removed.
- Whenever ground wires are removed during servicing, these ground wires must be reconnected to ensure that the washer is properly grounded.

W003

IMPORTANT: When installing module springs, make sure spring hook is fully seated in hole and in formed depression in tub skirt.

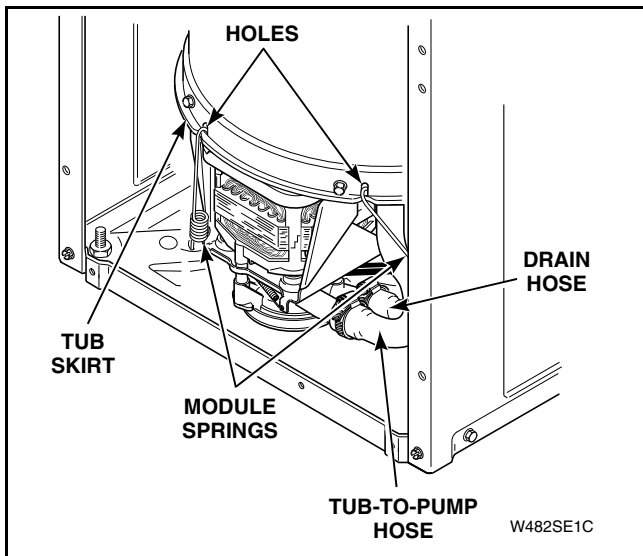

Figure 53

- r. Loosen hose clamp and remove drain hose from pump outlet. Refer to *Figure 53*.
- s. Loosen hose clamp and remove pressure hose from pressure bulb.
- t. Remove wire tie holding motor wire harness to support leg.
- u. Grasp outer tub and lift complete tub module assembly straight up and out of washer cabinet.
- v. Turn outer tub upside-down and set on protective padding.
- w. Remove motor and mounting bracket. Refer to *Paragraph 30*.
- x. Remove screws and lockwashers holding counterweight and each support leg to outer tub. Refer to *Figure 54*. Then lift transmission, weldment assembly and counterweight off tub.
- y. Loosen hose clamp and remove tub-to-pump hose, from bottom of outer tub. Refer to *Figure 53*.

NOTE: To prevent porcelain damage, leg plates must be installed on outside of outer tub flange when reinstalling support legs of weldment assembly. Do not overtighten screws as this could cause stripping or porcelain damage. Torque screws between 90 to 130 inch-pounds (10.30 to 14.87 N-M).

- z. Turn outer tub upright and remove pressure bulb and grommet.

NOTE: When installing grommet into outer tub, thicker lip of grommet must be installed to outside of tub. Lubricate outer surface of large opening of pressure bulb with liquid soap to aid when assembling pressure bulb into grommet.

IMPORTANT: When reinstalling complete tub module, carefully set the tub module pivot dome on top of friction ring. **DO NOT ALLOW TUB MODULE TO BE DROPPED OR LOWERED INTO POSITION TOO HARD!** This can damage or crack the friction ring.

39. DRIVE PULLEY, HELIX AND BRAKE

- a. Open loading door.
- b. Remove agitator by placing two agitator hooks, No. 254P4P, under bottom edge of agitator. Refer to *Figure 29*.

IMPORTANT: Hooks should be positioned **180 degrees from each other, and must be placed under agitator vane for greater stability. If hooks are placed between vane area, agitator damage may occur.**

- c. Using a rocking motion (back and forth) carefully lift agitator off drive bell.
- d. Remove two screws from bottom edge of front panel. Refer to *Figure 37*.
- e. Pull bottom of panel away from washer until hold down clips (located on top flange of panel) disengage from slots in cabinet top.
- f. **METERED MODELS:**
 - (1) Unlock and remove meter case service door.



WARNING

To reduce the risk of electric shock, fire, explosion, serious injury or death:

- Disconnect electric power to the washer before servicing.
- Never start the washer with any guards/panels removed.
- Whenever ground wires are removed during servicing, these ground wires must be reconnected to ensure that the washer is properly grounded.

W003

- (2) Remove timer bracket cap screw. Refer to *Figure 9*.
- (3) Slide timer and bracket toward rear of meter case to disengage bracket from shoulder screw. Lift timer and bracket out of meter case through service door opening as far as wires will permit.
- (4) Remove shoulder screw from inside meter case.
- (5) Remove two cabinet top hold down screws.
- (6) Remove security bolt (if present) from left rear corner of cabinet top.

NOTE: When lowering cabinet top into position or reinstalling cabinet top, pivot outer tub forward far enough to prevent damaging (bending) loading door switch lever.

- g. If area or space permits, tape loading door closed and lift cabinet top to a vertical position by hinging it on the rear hinges.

NOTE: Cabinet top is self supporting, however, a small chain may be used for additional support. Refer to *Figure 38*.

- h. Loosen hose clamp, and disconnect filler hose from outer tub cover. Refer to *Figure 46*.

NOTE: When reinstalling filler hose, white line on hose must face toward front of washer. Refer to *Figure 46*.

- i. Reach in through front of motor mounting bracket and move idler lever to left to release tension on belt.
- j. While holding idler lever, reach in and around right side of motor and run belt off right side of pulley.
- k. Using No. 289P4 Spring Hook Tool, unhook six module springs from lower edge of outer tub. Refer to *Figure 53*.

IMPORTANT: When installing module springs, make sure spring hook is fully seated in hole and in formed depression in tub skirt.

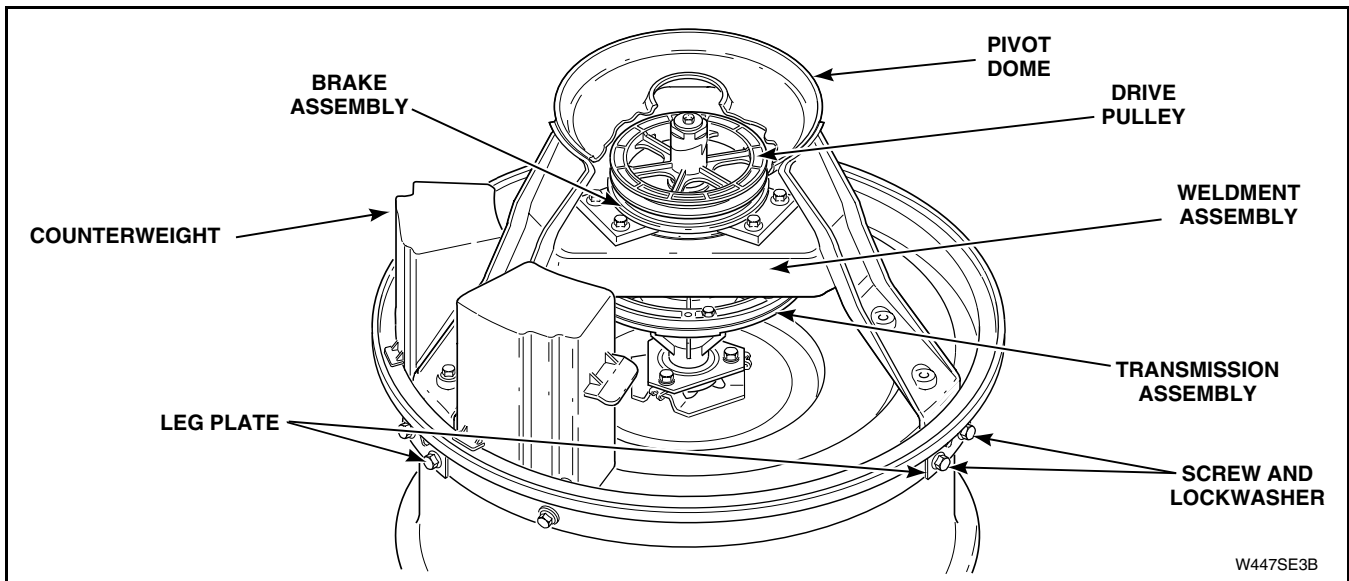

Figure 54

W447SE3B



WARNING

To reduce the risk of electric shock, fire, explosion, serious injury or death:

- Disconnect electric power to the washer before servicing.
- Never start the washer with any guards/panels removed.
- Whenever ground wires are removed during servicing, these ground wires must be reconnected to ensure that the washer is properly grounded.

W003

- l. Loosen hose clamp and remove drain hose from pump outlet. Refer to *Figure 53*.
- m. Loosen hose clamp and remove pressure hose from pressure bulb.
- n. Remove motor wire harness from support leg, then disconnect wire harness from motor switch by pressing down on top of connection block and at the same time pull connection block away from motor switch. Disconnect wires from capacitor.
- o. Grasp outer tub and lift complete tub module assembly (with transmission and weldment assembly attached) straight up and out of washer cabinet.
- p. Turn complete tub module upside-down and set on protective padding.
- q. Remove screw, washer and helix holding drive pulley to input shaft and transmission assembly. Refer to *Figure 55*.

- r. Lift drive pulley up and off input shaft of transmission assembly.

NOTE: When reinstalling pulley, place a small amount of No. 03200P Lubricant on top side of the drive pulley that will be contacting large flat washers. Refer to *Figure 55* for assembly sequence. Lubricate helix ramps and bore with a small amount of No. 03200P Lubricant. Refer to *Figure 56*.

IMPORTANT: DO NOT OVER LUBRICATE! Excess lubricant can be thrown into pivot dome area during normal washer operation. Any lubricant on pivot dome, base or friction ring will affect washer operation. This condition will persist until lubricant is removed.

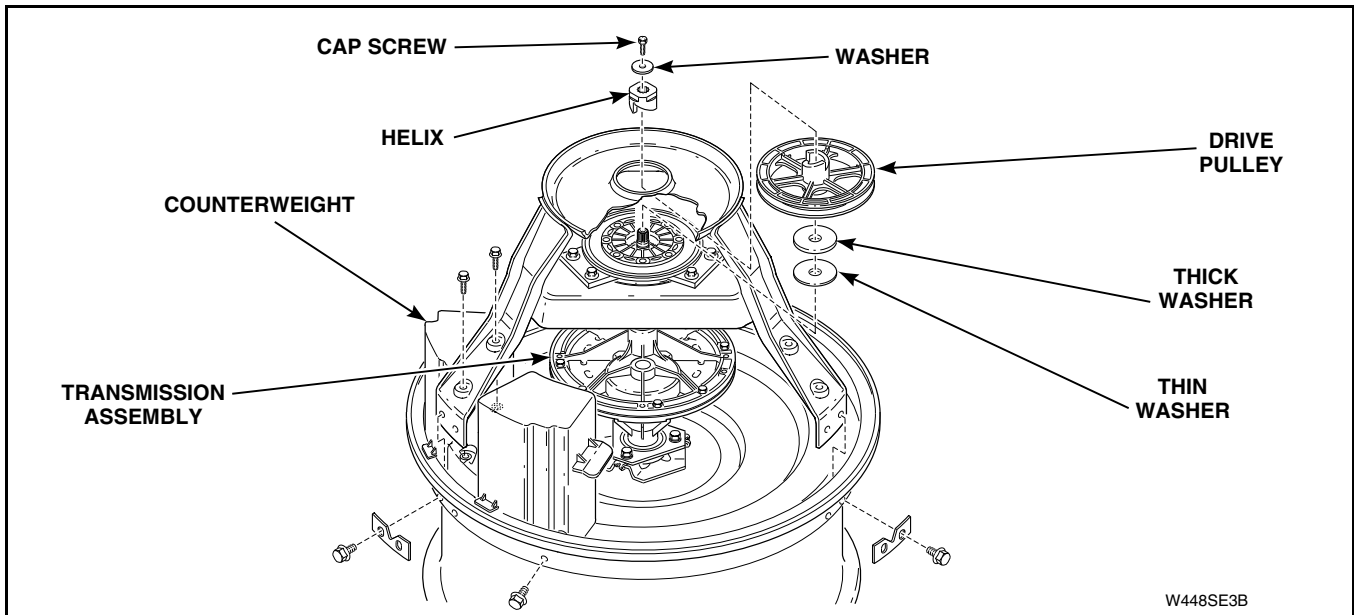

Figure 55

W448SE3B

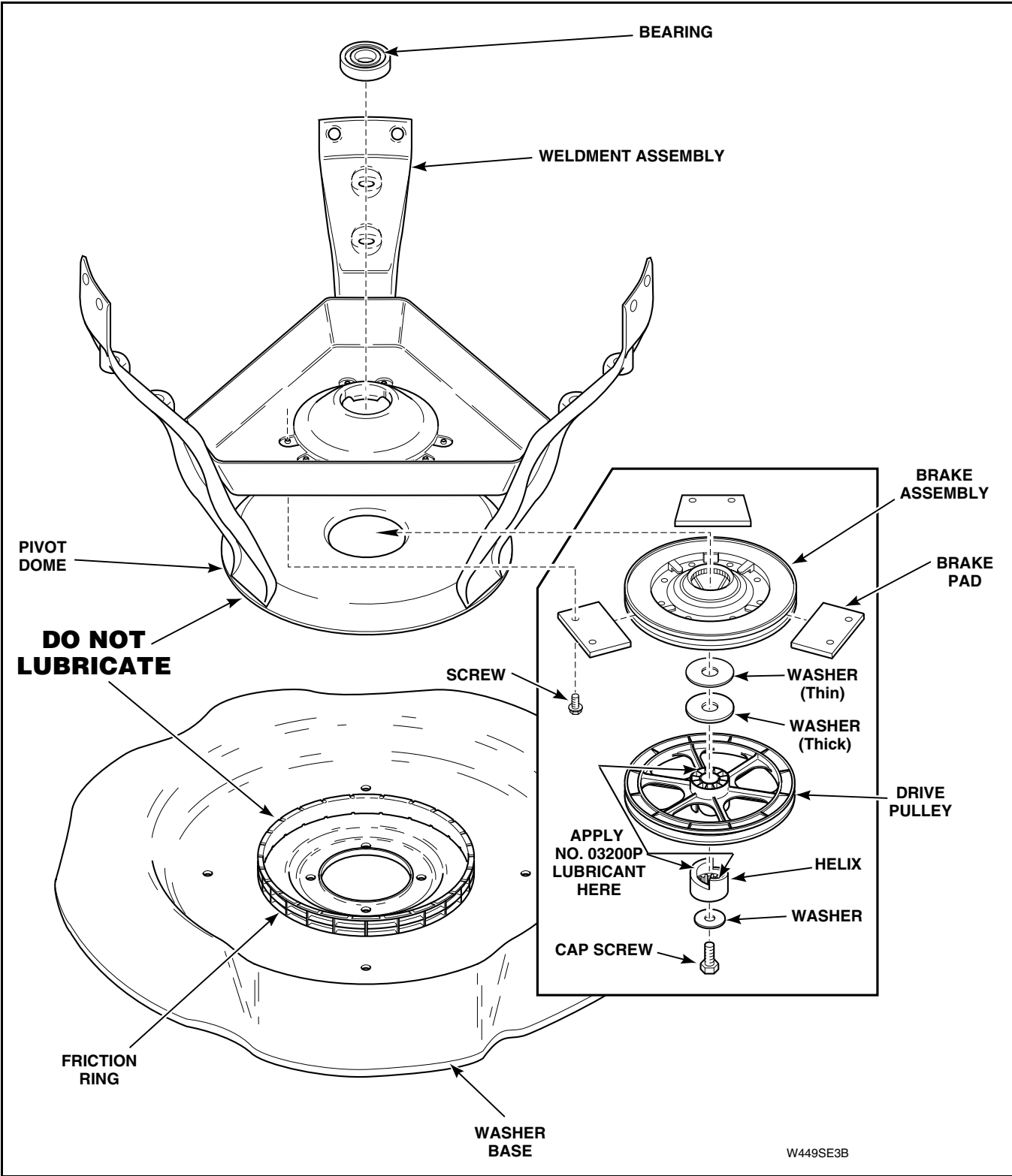

Figure 56



WARNING

To reduce the risk of electric shock, fire, explosion, serious injury or death:

- Disconnect electric power to the washer before servicing.
- Never start the washer with any guards/panels removed.
- Whenever ground wires are removed during servicing, these ground wires must be reconnected to ensure that the washer is properly grounded.

W003

- s. Remove screws holding three brake pads and brake assembly to weldment assembly. Refer to *Figure 56*. Then remove brake assembly and pads off bottom of weldment assembly.

IMPORTANT: When reinstalling brake assembly, we recommend replacing three brake pads. **DO NOT** replace worn pads only. Apply a small amount of No. 26594P Silicone Lubricant to both sides of each brake pad where it will contact brake assembly.

IMPORTANT: DO NOT OVER LUBRICATE! Excess lubricant can be thrown into pivot dome area during normal washer operation. Any lubricant on pivot dome, base or friction ring will affect washer operation. This condition will persist until lubricant is removed.

IMPORTANT: After installing complete tub module in washer and all hoses have been reconnected, add at least a quart of water to washtub to lubricate pump seals. Running a pump without water will ruin the seals.

NOTE: Refer to *Figure 56* for assembly sequence.

- t. After brake is installed, put washer through the following check to make sure brake is operating properly.
- (1) Turn off electrical power to washer.
 - (2) Turn drive pulley one complete revolution in agitation directly, then push drive pulley up against brake.
 - (3) Check for a .030 (.76 mm) minimum gap between drive pulley and helix **ramp** surfaces.

IMPORTANT: If gap is less than .030 (.76 mm), brake may not stop washtub from spinning in required seven seconds because brake will not close properly.

- (4) Turn on electrical power to washer and start washer in the final spin.

NOTE: ALL MODELS WITHOUT THE LETTER “M” IN THE EIGHTH CHARACTER OF THE MODEL NUMBER – After washtub has been spinning for two minutes, normal spin speed should be 640 ± 20 RPM one speed models; 640 ± 20 RPM **FAST** speed, or 427 ± 20 RPM **SLOW** speed on two speed models. If not, the cause could be dragging brake pads. If problems occur with steps three or four, remove brake assembly and correct problem.

NOTE: ALL MODELS WITH THE LETTER “M” IN THE EIGHTH CHARACTER OF THE MODEL NUMBER – After washtub has been spinning for two minutes, normal spin speed should be 710 ± 20 RPM one speed models; 710 ± 20 RPM **FAST** speed, or 473 ± 20 RPM **SLOW** speed on two speed models. If not, the cause could be dragging brake pads. If problems occur with steps three or four, remove brake assembly and correct problem.

40. WELDMENT AND BEARING ASSEMBLY

- a. Open loading door.
- b. Remove agitator by placing two agitator hooks, No. 254P4P, under bottom edge of agitator. Refer to *Figure 29*.

IMPORTANT: Hooks should be positioned **180 degrees from each other, and must be placed under agitator vane for greater stability. If hooks are placed between vane area, agitator damage may occur.**

- c. Using a rocking motion (back and forth) carefully lift agitator off drive bell.
- d. Remove two screws from bottom edge of front panel. Refer to *Figure 37*.
- e. Pull bottom of panel away from washer until hold down clips (located on top flange of panel) disengage from slots in cabinet top.
- f. **METERED MODELS:**
 - (1) Unlock and remove meter case service door.
 - (2) Remove timer bracket cap screw. Refer to *Figure 9*.



WARNING

To reduce the risk of electric shock, fire, explosion, serious injury or death:

- Disconnect electric power to the washer before servicing.
- Never start the washer with any guards/panels removed.
- Whenever ground wires are removed during servicing, these ground wires must be reconnected to ensure that the washer is properly grounded.

W003

- (3) Slide timer and bracket toward rear of meter case to disengage bracket from shoulder screw. Lift timer and bracket out of meter case through service door opening as far as wires will permit.
- (4) Remove shoulder screw from inside meter case.
- (5) Remove two cabinet top hold down screws.
- (6) Remove security bolt (if present) from left rear corner of cabinet top.

NOTE: When lowering cabinet top into position or reinstalling cabinet top, pivot outer tub forward far enough to prevent damaging (bending) loading door switch lever.

- g. If area or space permits, tape loading door closed and lift cabinet top to a vertical position by hinging it on the rear hinges.

NOTE: Cabinet top is self supporting, however, a small chain may be used for additional support. Refer to Figure 38.

- h. Loosen hose clamp, and disconnect filler hose from outer tub cover. Refer to Figure 46.

NOTE: When installing filler hose, white line on hose must point toward front of washer. Refer to Figure 46.

- i. Reach in through front of motor mounting bracket and move idler lever to left to release tension on belt.

IMPORTANT: Use care when releasing idler lever tension. If idler lever spring is overstretched, washer operation will be affected.

- j. While holding idler lever, reach in and around right side of motor and run belt off right side of pulley.
- k. Using No. 289P4 Spring Hook Tool, unhook six module springs from lower edge of outer tub. Refer to Figure 53.

IMPORTANT: When installing module springs, make sure spring hook is fully seated in hole in tub skirt.

- l. Loosen hose clamp and remove drain hose from pump outlet. Refer to Figure 53.
- m. Loosen hose clamp and remove pressure hose from pressure bulb.
- n. Remove motor wire harness from support leg, then disconnect wire harness from motor switch by pressing down on top of connection block and at the same time pull connection block away from motor switch. Disconnect wires from capacitor.
- o. Grasp outer tub and lift complete tub module assembly (with transmission and weldment assembly attached) straight up and out of washer cabinet.
- p. Turn complete tub module upside-down and set on protective padding.
- q. Remove screw, washer and helix holding drive pulley to input shaft and transmission assembly. Refer to Figure 55.
- r. Lift drive pulley up and off input shaft of transmission assembly.

NOTE: When reinstalling pulley, place a small amount of No. 03200P Lubricant on top side of the drive pulley that will be contacting large flat washers. Refer to Figure 55 for assembly sequence. Lubricate helix ramps and bore with a small amount of No. 03200P Lubricant. Refer to Figure 56.

IMPORTANT: DO NOT OVER LUBRICATE! Excess lubricant can be thrown into pivot dome area during normal washer operation. Any lubricant on pivot dome, base or friction ring will affect washer operation. This condition will persist until lubricant is removed.

- s. Remove screws holding three brake pads and brake assembly to weldment assembly. Refer to Figure 56. Then remove brake assembly and pads off bottom of weldment assembly.

IMPORTANT: When reinstalling brake assembly, we recommend replacing three brake pads. DO NOT replace worn pads only. Apply a small amount of No. 265494P Silicone Lubricant to both sides of each brake pad where it will contact brake assembly.



WARNING

To reduce the risk of electric shock, fire, explosion, serious injury or death:

- Disconnect electric power to the washer before servicing.
- Never start the washer with any guards/panels removed.
- Whenever ground wires are removed during servicing, these ground wires must be reconnected to ensure that the washer is properly grounded.

W003

IMPORTANT: DO NOT OVER LUBRICATE!

Excess lubricant can be thrown into pivot dome area during normal washer operation. Any lubricant on pivot dome, base or friction ring will affect washer operation. This condition will persist until lubricant is removed.

IMPORTANT: After installing complete tub module in washer and all hoses have been reconnected, add at least a quart of water to washtub to lubricate pump seals. Running a pump without water will ruin the seals.

NOTE: Refer to *Figure 56* for assembly sequence.

- t. After brake is installed, put washer through the following check to make sure brake is operating properly.
 - (1) Turn off electrical power to washer.
 - (2) Turn drive pulley one complete revolution in agitation direction, then push drive pulley up against brake.
 - (3) Check for a .030 (.76 mm) minimum gap between drive pulley and helix ramp surfaces.

IMPORTANT: If gap is less than .030 (.76 mm), brake may not stop washtub from spinning in required seven seconds because brake will not close properly.

- (4) Turn on electrical power to washer and start washer in the final spin.

NOTE: ALL MODELS WITHOUT THE LETTER “M” IN THE EIGHTH CHARACTER OF THE MODEL NUMBER – After washtub has been spinning for two minutes, normal spin speed should be 640 ± 20 RPM one speed models; 640 ± 20 RPM **FAST** speed, or 427 ± 20 RPM **SLOW** speed on two speed models. If not, the cause could be dragging brake pads. If problems occur with steps three or four, remove brake assembly and correct problem.

NOTE: ALL MODELS WITH THE LETTER “M” IN THE EIGHTH CHARACTER OF THE MODEL NUMBER – After washtub has been spinning for two minutes, normal spin speed should be 710 ± 20 RPM one speed models; 710 ± 20 RPM **FAST** speed, or 473 ± 20 RPM **SLOW** speed on two speed models. If not, the cause could be dragging brake pads. If problems occur with steps three or four, remove brake assembly and correct problem.

- u. Remove screws and lockwashers holding counterweight and each support leg to outer tub. Refer to *Figure 55*. Then lift weldment assembly and counterweight off tub.

NOTE: It may be necessary to tap lightly on the weldment assembly to loosen it from transmission tube.

NOTE: To prevent porcelain damage, leg plates must be installed on outside of outer tub flange when reinstalling support legs of weldment assembly. Do not overtighten screws as this could cause stripping or porcelain damage. Torque screws between 90 to 130 inch-pounds (10.30 to 14.87 N-m).

- v. Remove screws and washers holding counterweight to leg on weldment assembly.

41. TRANSMISSION ASSEMBLY

- a. Open loading door.
- b. Remove agitator by placing two agitator hooks, No. 254P4P, under bottom edge of agitator. Refer to *Figure 29*.

IMPORTANT: Hooks should be positioned 180 degrees from each other, and must be placed under agitator vane for greater stability. If hooks are placed between vane area, agitator damage may occur.

- c. Using a rocking motion (back and forth) carefully lift agitator off drive bell.
- d. Remove two screws from bottom edge of front panel. Refer to *Figure 37*.



WARNING

To reduce the risk of electric shock, fire, explosion, serious injury or death:

- **Disconnect electric power to the washer before servicing.**
- **Never start the washer with any guards/panels removed.**
- **Whenever ground wires are removed during servicing, these ground wires must be reconnected to ensure that the washer is properly grounded.**

W003

- e. Pull bottom of panel away from washer until hold down clips (located on top flange of panel) disengage from slots in cabinet top.

f. METERED MODELS:

- (1) Unlock and remove meter case service door.
- (2) Remove timer bracket cap screw. Refer to *Figure 9*.
- (3) Slide timer and bracket toward rear of meter case to disengage bracket from shoulder screw. Lift timer and bracket out of meter case through service door opening as far as wires will permit.
- (4) Remove shoulder screw from inside meter case.
- (5) Remove two cabinet top hold down screws.
- (6) Remove security bolt (if present) from left rear corner of cabinet top.

NOTE: When lowering cabinet top into position or reinstalling cabinet top, pivot outer tub forward far enough to prevent damaging (bending) loading door switch lever.

- g. If area or space permits, tape loading door closed and lift cabinet top to a vertical position by hinging it on the rear hinges.

NOTE: Cabinet top is self supporting, however, a small chain may be used for additional support. Refer to *Figure 38*.

- h. Loosen hose clamp, and disconnect filler hose from tub cover. Refer to *Figure 46*.

NOTE: When installing filler hose, white line on hose must point toward front of washer. Refer to *Figure 46*.

TUB COVER AND GASKET

- (1) There are eight tub cover hold-down tabs which snap over the outer tub flange. Place your fingers under the flaps of the hold-down tab of the tub cover and pull out on the flap and at the same time lift upward on cover to unsnap hold-down tabs from outer tub flange. One by one, disengage each of the eight hold-down tabs from outer tub flange and remove cover.

- (2) Remove cover from outer tub and remove old gasket from tub cover.

NOTE: When installing tub cover, always use a new cover gasket.

NOTE: Clean and remove any foreign material in gasket groove of tub cover and outer tub flange.

- (3) Starting at positioning pin located at the bleach funnel area, lay gasket into gasket groove of tub cover. Refer to *Figure 48*.
- (4) Using your fingers, press gasket down into gasket groove of tub cover. Avoid pressing gasket past ends of hold-down tabs.

IMPORTANT: Care must be taken not to twist or bunch gasket in any one area to avoid leaks after assembly.

- (5) Early models – Install gasket past ends of hold-down tabs to bottom of gasket groove using semi-curved end of tub cover gasket tool part No. 273P4.

NOTE: Gasket tool, Part No. 273P4, is designed to spread open hold-down tabs to prevent tearing of gasket during installation.

- i. Remove screws and washers holding washtub to hub. Refer to *Figure 49*.

IMPORTANT: Porcelain Washtub Models — Use care when tightening cap screws to avoid chipping porcelain on washtub.

- j. Lift washtub (with balance ring attached) out of outer tub

IMPORTANT: When removing washtub and balance ring, DO NOT lift up on balance ring as you could damage it. Grasp top flange of washtub and remove from outer tub.

- k. Remove agitator drive bell. Refer to *Paragraph 27*.
- l. Remove large hex nut using No. 306P4 Hex Wrench. Then remove spline insert from transmission tube.
- m. Remove hub from splines on transmission tube.



WARNING

To reduce the risk of electric shock, fire, explosion, serious injury or death:

- Disconnect electric power to the washer before servicing.
- Never start the washer with any guards/panels removed.
- Whenever ground wires are removed during servicing, these ground wires must be reconnected to ensure that the washer is properly grounded.

W003

NOTE: It may be necessary to use a gear puller to remove hub.

- n. Remove old water seal from outer tub.

IMPORTANT: Use care when removing old seal so as not to damage tub flange or porcelain.

NOTE: When reinstalling or replacing outer tub, always install a new No. 646P3 Hub and Seal Kit. Refer to *Paragraph 37*.

- o. Using No. 289P4 Spring Hook Tool, unhook six module springs from lower edge of outer tub. Refer to *Figure 54*.

IMPORTANT: When installing module springs, make sure spring hook is fully seated in hole in tub skirt. Mark the word “FRONT” on front side of outer tub so complete tub module can be reinstalled in same position.

- p. Loosen hose clamp and remove hose from bottom of outer tub.

IMPORTANT: Some water will always remain in outer tub. Therefore, before removing hose from pump, pinch off or drain hose to prevent water spillage.

- q. Loosen hose clamp and remove pressure hose from pressure bulb. Refer to *Figure 44*.
 r. Remove wire tie holding motor wire harness to support leg.
 s. Grasp outer tub and lift complete tub module assembly straight up and out of washer cabinet.

- t. Turn outer tub upside-down and set on protective padding.
 u. Remove screw, washer and helix holding drive pulley to input shaft of transmission assembly. Refer to *Figure 55*.
 v. Lift drive pulley up and out from between support legs.

NOTE: When reinstalling pulley, place a small amount of No. 03200P Lubricant to top side of drive pulley that will be contacting the large flat washer. Lubricate helix ramps with a small amount of No. 03200P Lubricant. Refer to *Figure 56*.

IMPORTANT: DO NOT OVER LUBRICATE! Excess lubricant can be thrown into pivot dome area during normal washer operation. Any lubricant on pivot dome, base or friction ring will affect washer operation. This condition will persist until lubricant is removed.

- w. Remove two screws holding counterweight to support leg.
 x. Remove screws and lockwashers holding each support leg to outer tub. Refer to *Figure 56*. Then lift weldment assembly off transmission tube.

NOTE: It may be necessary to tap lightly on weldment assembly to loosen it from transmission tube.

- y. Lift transmission assembly out of upper bearing.



WARNING

To reduce the risk of electric shock, fire, explosion, serious injury or death:

- Disconnect electric power to the washer before servicing.
- Never start the washer with any guards/panels removed.
- Whenever ground wires are removed during servicing, these ground wires must be reconnected to ensure that the washer is properly grounded.

W003

NOTE: When installing lower bearing, weldment assembly and brake assembly, apply No. 27604P Anti-Seeze Compound to area of transmission tube that will be contacting bearing, washtub hub and brake assembly. Refer to *Figure 57*.

To prevent porcelain damage, leg plates must be installed on outside of outer tub flange when reinstalling support legs of weldment assembly. Refer to *Figure 54*. Do not overtighten screws as this could cause stripping or porcelain damage. Torque screws between 90 to 130 inch-pounds (10.30 to 14.87 N-m).

IMPORTANT: When replacing or reinstalling transmission assembly, it is important that No. 27604P Anti-Seeze Compound be applied to area of the transmission tubes where they will be contacting upper and lower bearings. Refer to *Figure 57*.

Carefully lower transmission through upper bearing. **DO NOT DROP OR LOWER TRANSMISSION ASSEMBLY INTO POSITION TOO HARD.** This can cause bearing to move which will cause vibration, noise, wear or no spin.

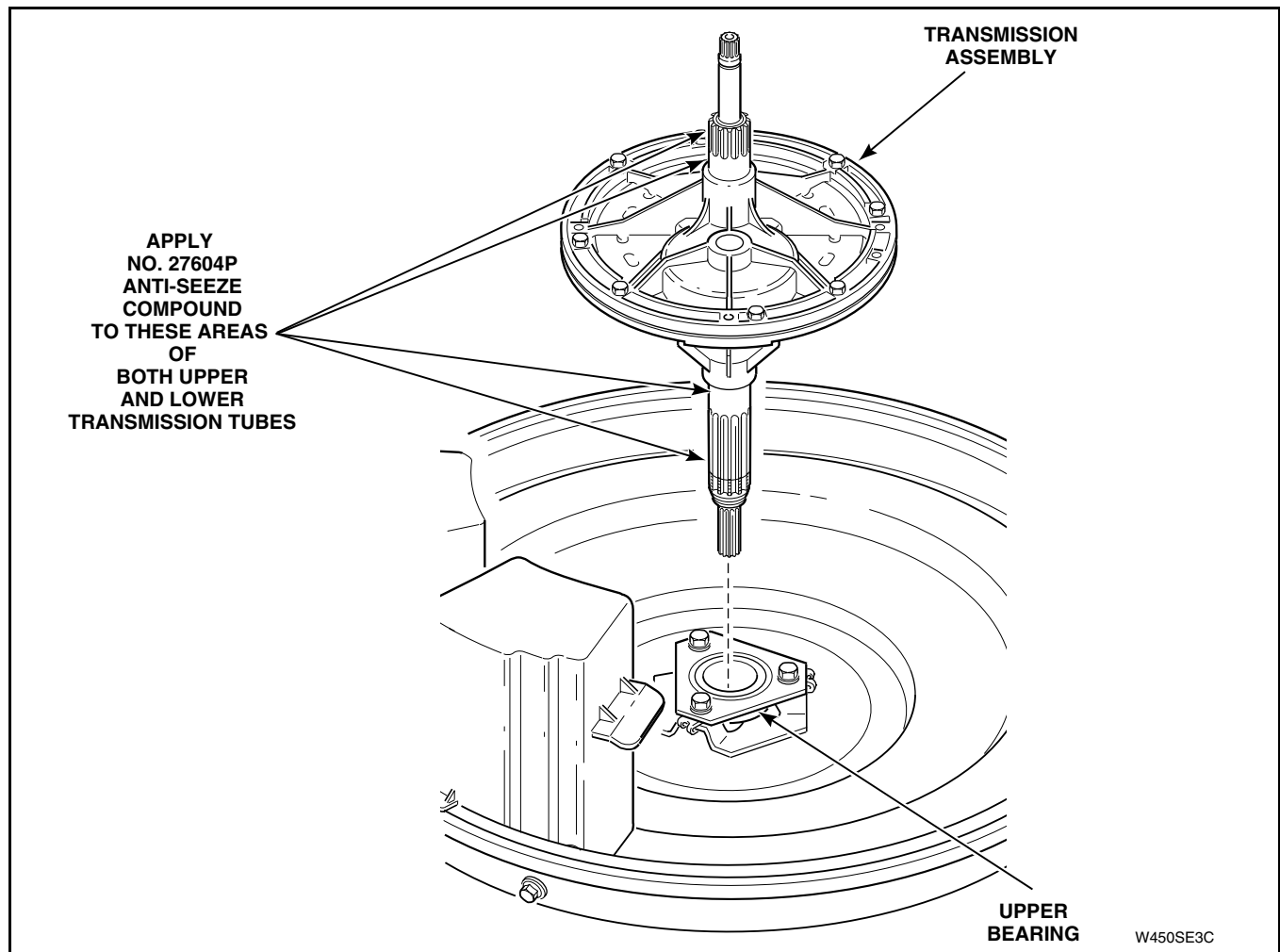

Figure 57



WARNING

To reduce the risk of electric shock, fire, explosion, serious injury or death:

- Disconnect electric power to the washer before servicing.
- Never start the washer with any guards/panels removed.
- Whenever ground wires are removed during servicing, these ground wires must be reconnected to ensure that the washer is properly grounded.

W003

TO DISASSEMBLE TRANSMISSION ASSEMBLY (Refer to *Figure 58* for Assembly Sequence)

- a. Place transmission in a vise with input shaft end up. Clamp only the case, not the shaft.

NOTE: Supporting transmission in this manner will allow oil to collect in the transmission case.

- b. Before disassembling transmission halves, mark outer edge of transmission case and cover so two can be reassembled in the same position.
- c. Place transmission in vise so three of the eight screws holding transmission case and cover together are in the twelve, four and seven o'clock positions.
- d. Loosen three screws, mentioned in step "c", approximately two turns. **DO NOT** remove these three screws at this time. Remove remaining five screws and lockwashers completely.
- e. Remove transmission assembly from vise.
- f. While holding transmission by cover end, gently tap each of the three remaining screws until two halves separate. Place assembly back into vise (cover end up) and remove three screws and lockwashers.
- g. Remove screw and washer holding reduction gear to transmission cover and remove gear.
- h. Remove special screw, lockwasher and flat washer holding drive pinion to input shaft.

NOTE: To prevent input shaft from turning during removal of special screw, place an old helix onto shaft and hold helix with a locking pliers.

- i. Remove drive pinion from input shaft using a hammer and punch to drive shaft out of pinion.
- j. Remove input shaft from transmission cover.

IMPORTANT: Carefully examine area inside cover tube (seals, bearing, roller clutch, etc.). If oil is present between seals and bearing, or roller clutch is bad, it will require replacing complete transmission cover assembly. These components are not available separately.

- k. Remove internal gear, slide and rack from transmission case.
 - l. Remove transmission case from vise and drain oil.
- m. Remove retainer ring from output shaft.
- n. Using a hammer and punch, carefully drive shaft out of agitator pinion.
- o. Carefully remove output shaft and washer from transmission case.

IMPORTANT: Carefully examine area inside transmission case tube (seals, bearings, etc.). If oil is present between seals and bearings, it will require replacing complete transmission case. Seals and bearings are not available separately.

IMPORTANT: Transmissions produced after 5/95 may be difficult to disassemble. Take extra care not to damage sealing surfaces of transmission case and cover.



WARNING

To reduce the risk of electric shock, fire, explosion, serious injury or death:

- Disconnect electric power to the washer before servicing.
- Never start the washer with any guards/panels removed.
- Whenever ground wires are removed during servicing, these ground wires must be reconnected to ensure that the washer is properly grounded.

W003

TO REASSEMBLE TRANSMISSION ASSEMBLY

IMPORTANT: Wash all components in a cleaning solution (mineral spirits). Wipe inside of transmission case and cover with a clean cloth, dampened with cleaning solution, to remove any impurities. **DO NOT** allow cleaning solution to come in contact with bearings and seals in transmission case and/or cover.

- a. Carefully insert output shaft and washer into transmission case.
- b. Place agitator pinion on splines of output shaft and press onto shaft.
- c. Install retainer ring on output shaft.
- d. Place transmission case into a vise. Clamp only the case, not the shaft.
- e. Place rack inside transmission case with rack resting on bar in case. Agitator pinion must engage the rack.

NOTE: Put a light film of transmission oil on bar where rack will slide back and forth.

- f. Position slide in slot in rack.

NOTE: Put a light film of transmission oil in slot on rack, and also the transmission case where internal gear will ride.

- g. Place internal gear into transmission case. Make sure guide pin on internal gear fits in hole in slide.

IMPORTANT: Never install a used internal gear in a new transmission case. If transmission case and internal gear are to be reused, be sure they are used as the original set.

- h. Refill transmission case with new No. 27243P Transmission Oil (one fill).
- i. To prevent seal damage, insert input shaft into cover starting at outer end of cover tube.

IMPORTANT: End of shaft with identification groove must be facing outward. Refer to *Figure 58*. This is the end that will mate with the helix.

- j. Install drive pinion, flat washer, lockwasher and special screw onto input shaft.

NOTE: Use a thread locking compound on threads of special screw to prevent screw from loosening on shaft.

IMPORTANT: Make sure mating surfaces of transmission cover and case are free of oil or any other foreign material.

- k. Place reduction gear on stub shaft of cover and install screw and washer.
- l. Apply a bead of No. 37577P Sealant on mating surface of transmission case.

IMPORTANT: Bead of sealant should be no more than one sixteenth inch in diameter. **DO NOT** allow any sealant to contact edges of internal gear (sealant may damage moving parts).

NOTE: A transmission pin tool, Part No. 305P4, must be used to align the cover and case when reassembling the transmission after repair. The transmission pin tool must be used in sets of two and placed in the same holes shown in *Figure 58*. Both transmission pin tools must be left in place until all eight screws and nuts have been installed and tightened firmly, then remove the two pins.

- m. Carefully place transmission cover over top of transmission case. Make sure holes in cover line up with holes in case, and marked edges of two halves are aligned.
- n. Carefully lower cover onto case.
- o. Secure two transmission halves together, using eight screws removed during disassembly. Tighten eight screws evenly.
- p. Remove complete transmission assembly from vise.
- q. Apply Anti-Seeze Compound, No. 27604P, to smooth area of both transmission tubes that will be contacting upper and lower bearings. Refer to *Figure 57*.

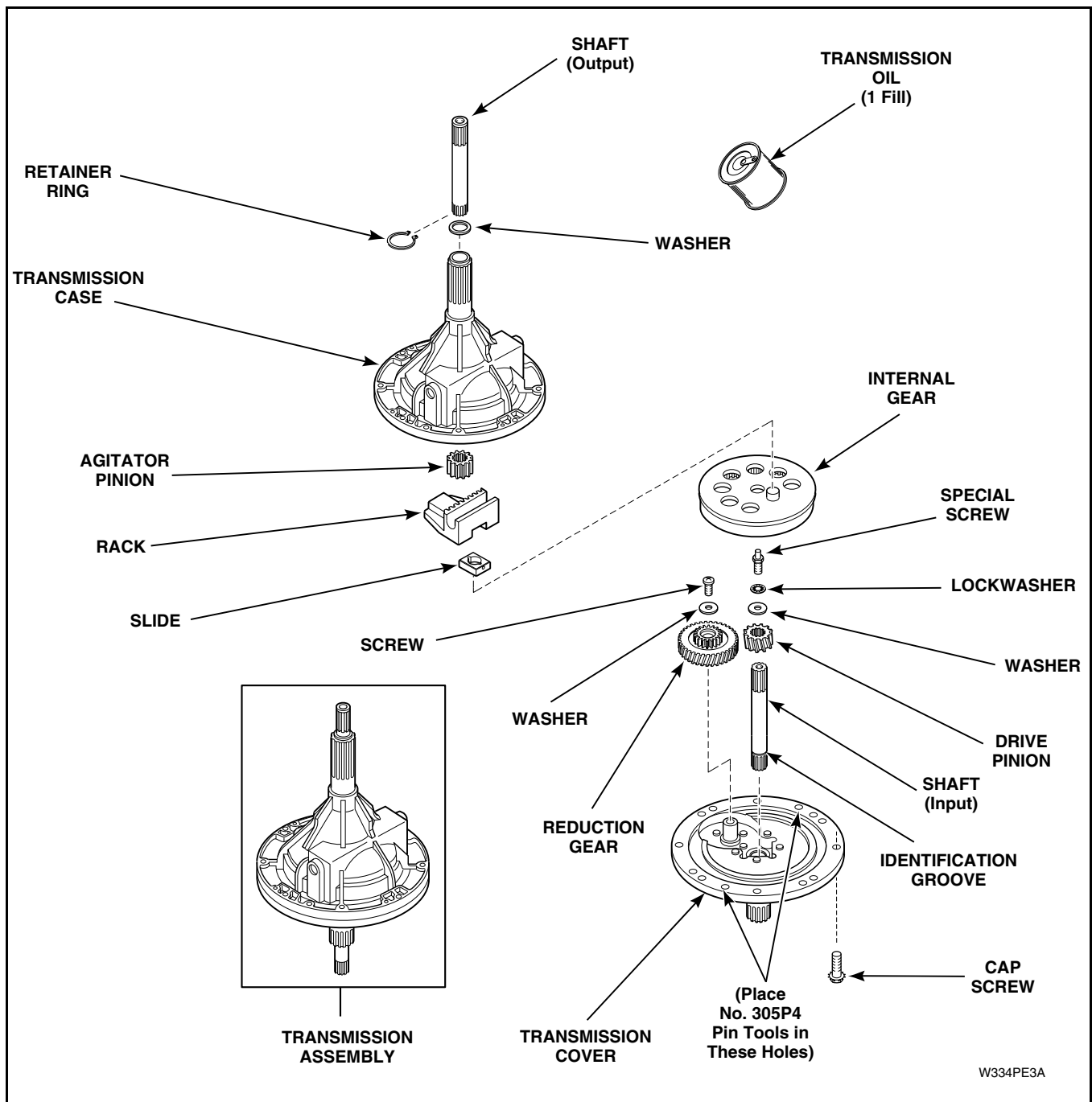

Figure 58



WARNING

To reduce the risk of electric shock, fire, explosion, serious injury or death:

- Disconnect electric power to the washer before servicing.
- Never start the washer with any guards/panels removed.
- Whenever ground wires are removed during servicing, these ground wires must be reconnected to ensure that the washer is properly grounded.

W003

42. UPPER BEARING ASSEMBLY

- Remove transmission assembly. Refer to *Paragraph 41*, steps “a” through “u”.
- Remove screws and lockwashers holding each support leg to outer tub. Refer to *Figure 54*.
- Lift complete weldment assembly (with drive pulley, brake assembly, lower bearing, and transmission assembly attached) off outer tub.

- Remove three screws holding upper bearing and housing to bottom of outer tub. Refer to *Figure 59*.

NOTE: Replace bearing and housing as an assembly. Refer to *Figure 59*.

NOTE: When upper bearing assembly is reinstalled, threads of cap screws must be secured with a retaining compound.

IMPORTANT: To prevent porcelain damage, leg plates must be installed on outer tub flange when reinstalling support legs. (Plate must be installed on outside of tub flange). Do not overtighten screws as this could cause stripping or porcelain damage.

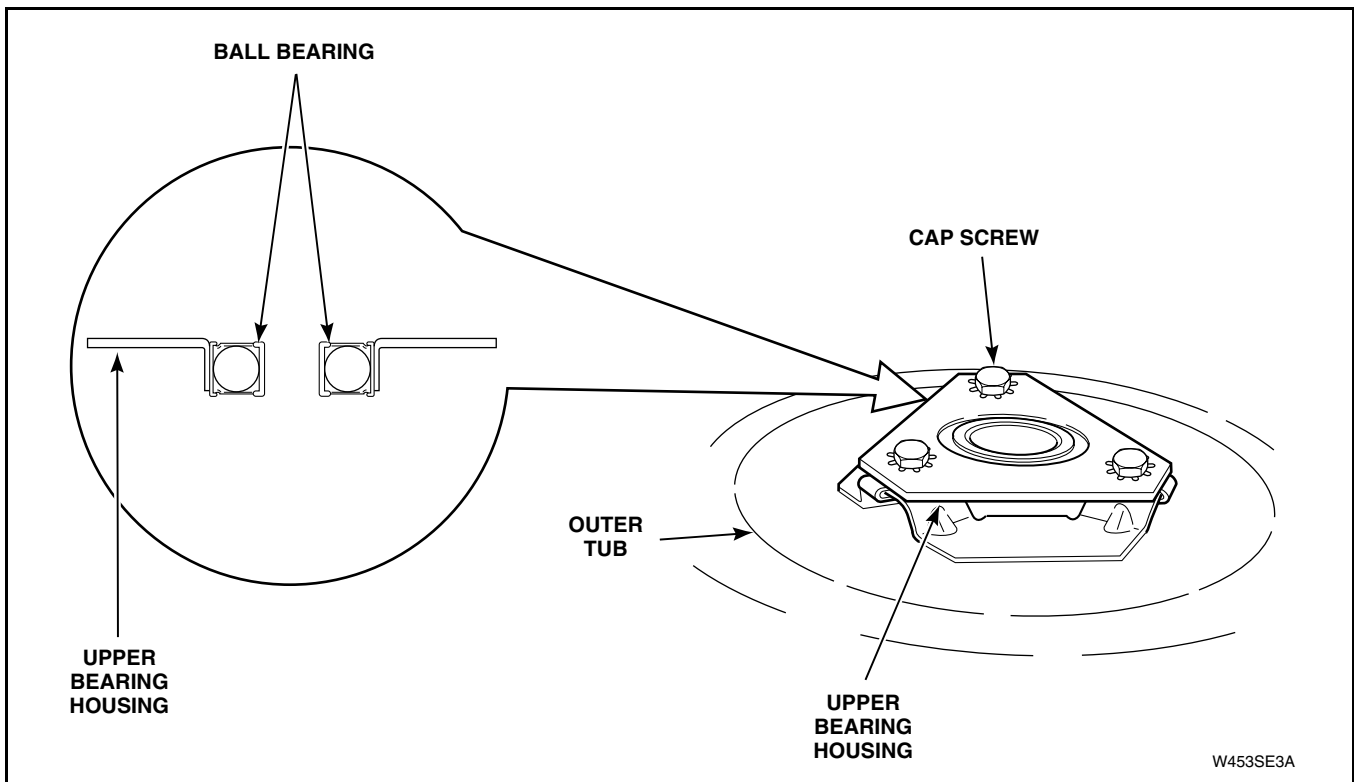

W453SE3A

Figure 59



WARNING

To reduce the risk of electric shock, fire, explosion, serious injury or death:

- Disconnect electric power to the washer before servicing.
- Never start the washer with any guards/panels removed.
- Whenever ground wires are removed during servicing, these ground wires must be reconnected to ensure that the washer is properly grounded.

W003

43. FRICTION RING

- a. Open loading door.
- b. Remove agitator by placing two agitator hooks, No. 254P4P, under bottom edge of agitator. Refer to *Figure 29*.

IMPORTANT: Hooks should be positioned 180 degrees from each other, and must be placed under agitator vane for greater stability. If hooks are placed between vane area, agitator damage may occur.

- c. Using a rocking motion (back and forth) carefully lift agitator off drive bell.
- d. Remove two screws from bottom edge of front panel. Refer to *Figure 37*.
- e. Pull bottom of panel away from washer until hold down clips (located on top flange of panel) disengage from slots in cabinet top.
- f. **METERED MODELS:**
 - (1) Unlock and remove meter case service door.
 - (2) Remove timer bracket cap screw. Refer to *Figure 9*.
 - (3) Slide timer and bracket toward rear of meter case to disengage bracket from shoulder screw. Lift timer and bracket out of meter case through service door opening as far as wires will permit.
 - (4) Remove shoulder screw from inside meter case.
 - (5) Remove two cabinet top hold down screws.
 - (6) Remove security bolt (if present) from left rear corner of cabinet top.

NOTE: When lowering cabinet top into position or reinstalling cabinet top, pivot outer tub forward far enough to prevent damaging (bending) loading door switch lever.

- g. If area or space permits, tape loading door closed and lift cabinet top to a vertical position by hinging it on the rear hinges.

NOTE: Cabinet top is self supporting, however, a small chain may be used for additional support. Refer to *Figure 38*.

- h. Loosen hose clamp, and disconnect filler hose from outer tub cover. Refer to *Figure 46*.

NOTE: When installing filler hose, white line on hose must point toward front of washer. Refer to *Figure 46*.

- i. Disconnect wire harness from motor switch by pressing down on locking tab on top of connection block and at the same time pull connection block away from motor switch. Disconnect wires from capacitor. Refer to *Figure 43*. Disconnect harness from leg by squeezing tabs on cable tie together and push it back through hole in leg.
- j. Loosen hose clamp and remove drain hose from pump outlet. Refer to *Figure 53*.
- k. Loosen hose clamp and remove pressure hose from pressure bulb. Refer to *Figure 44*.

IMPORTANT: To avoid an open circuit, DO NOT pull on terminal block wires when removing block from motor switch as this could damage wires or connection crimpings. Before attaching wire harness connection block to motor switch, make sure all male terminals on motor switch are straight and are capable of accepting terminals from wire harness connection block.

1. Using No. 289P4 Spring Hook Tool, unhook 6 module springs from lower edge of outer tub. Refer to *Figure 53*.

IMPORTANT: When installing module springs, make sure spring hook is fully seated in hole in tub skirt.

- m. Grasp outer tub and lift complete tub module assembly (with transmission and weldment assembly attached) straight up and out of washer cabinet and set out of the way.
- n. Remove old friction ring from washer base. Refer to *Figure 60*.
- o. Use a dry cloth or a cloth dampened with water and clean the surface of the base where new friction ring will be installed.



WARNING

To reduce the risk of electric shock, fire, explosion, serious injury or death:

- Disconnect electric power to the washer before servicing.
- Never start the washer with any guards/panels removed.
- Whenever ground wires are removed during servicing, these ground wires must be reconnected to ensure that the washer is properly grounded.

W003

- p. Carefully place complete tub module back into washer making sure the weldment assembly is positioned properly over the friction ring and the recess area of washer base.

IMPORTANT: When reinstalling complete tub module, carefully set the tub module pivot dome on top of friction ring. **DO NOT ALLOW TUB MODULE TO BE DROPPED OR LOWERED INTO POSITION TOO HARD!** This can damage or crack the friction ring.

NOTE: Be sure the motor and pump are facing toward front of washer.

- q. Use the No. 289P4 Spring Hook Tool and starting with the rear springs, hook 6 module springs into lower edge of outer tub. Refer to *Figure 53*.

IMPORTANT: When installing module springs, make sure spring hook is fully seated in hole in tub skirt. Refer to *Figure 53*.

- r. Connect hose to pump, then tighten hose clamp.
 s. Reconnect the connection block to motor switch. Refer to *Figure 43*. Reinstall cable tie in leg making sure it is secure.
 t. Reconnect pressure hose to pressure bulb. Refer to *Figure 61*. Then connect filler hose to tub cover. Refer to *Figure 61*.

NOTE: When reinstalling filler hose, white line on hose must point toward front of washer. Refer to *Figure 61*. Make sure hose is in its natural position (not kinked or twisted). If hose is not, loosen hose clamp and straighten hose.

- u. Reinstall cabinet top and washer front panel.
 v. Reconnect washer power cord and open water supply faucets.

NOTE: Washer must be run through a complete cycle to make sure it is operating properly.

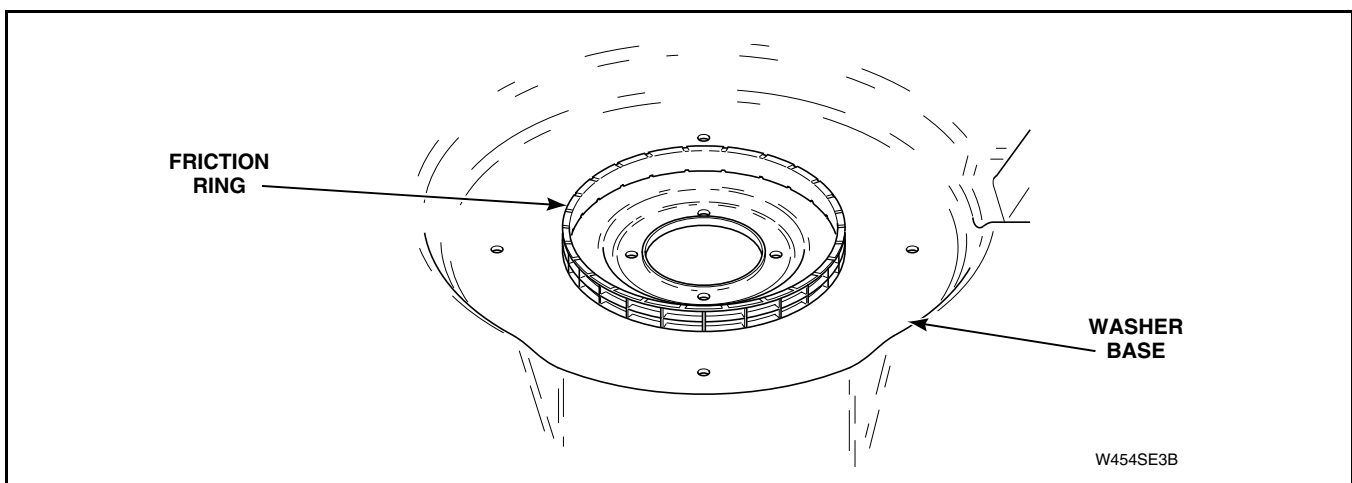

Figure 60

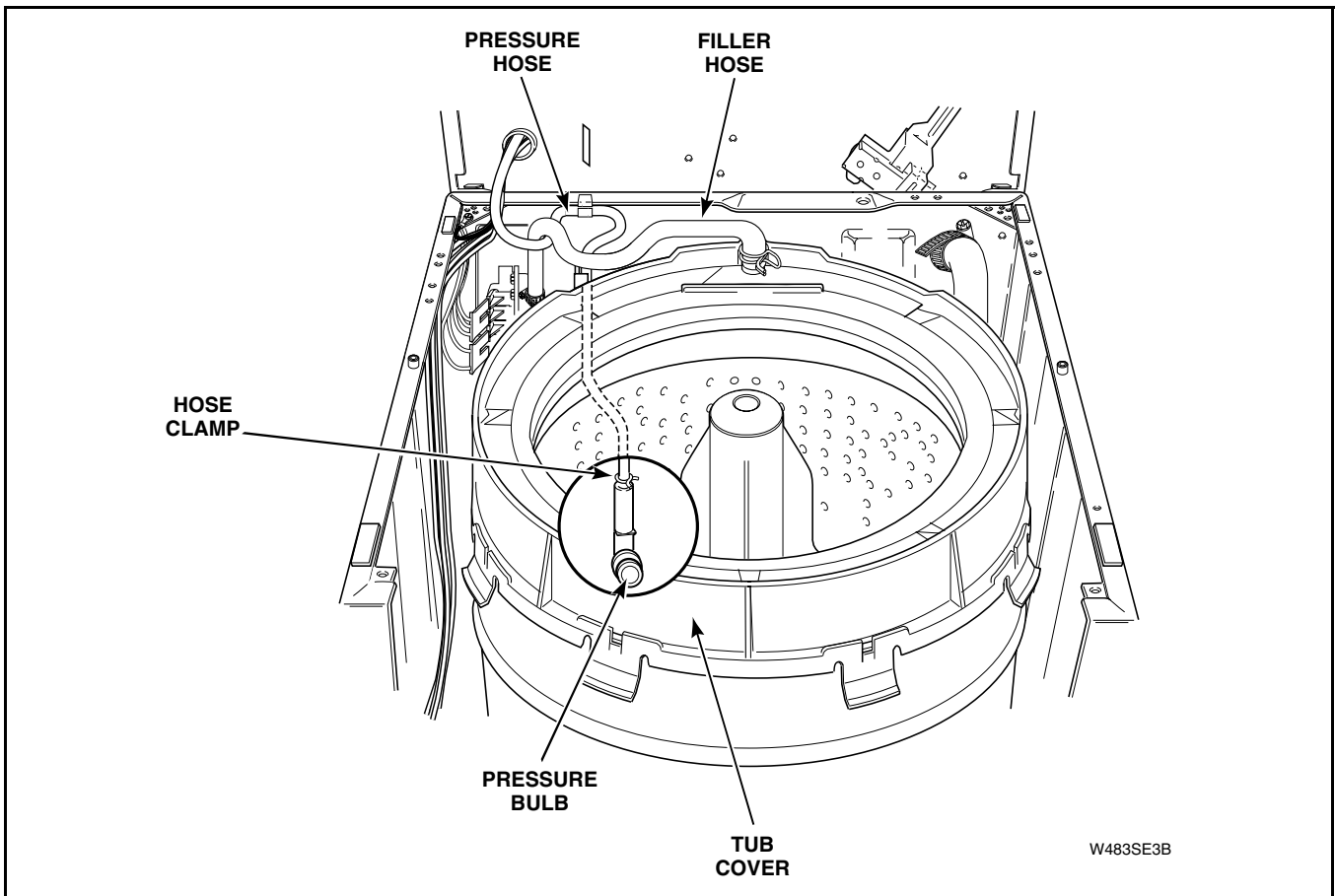

Figure 61

Section 6

Adjustments



WARNING

To reduce the risk of electric shock, fire, explosion, serious injury or death:

- Disconnect electric power to the washer before servicing.
- Never start the washer with any guards/panels removed.
- Whenever ground wires are removed during servicing, these ground wires must be reconnected to ensure that the washer is properly grounded.

W003

44. LEVELING LEGS

Refer to *Figure 62*

- Place rubber feet on all four leveling legs.
- Place washer in position on a clean, dry, and reasonably firm floor.
- Loosen locknuts and adjust two front leveling legs. Once adjusted, tilt washer forward on front legs and lower back down into position to set the rear self-leveling legs.
- Washer must not rock. After washer is at desired height, tighten locknuts securely against bottom of washer base. If these locknuts are not tight, washer will not remain stationary during operation.

NOTE: Install rear extension leg kit, No. 566P3, (optional equipment at extra cost) to raise height of washer.

NOTE: Improper installation, installation on carpet or flexing of a weak floor will cause excessive vibration.

IMPORTANT: Do not slide washer across floor once leveling legs have been extended, as legs and base could become damaged.

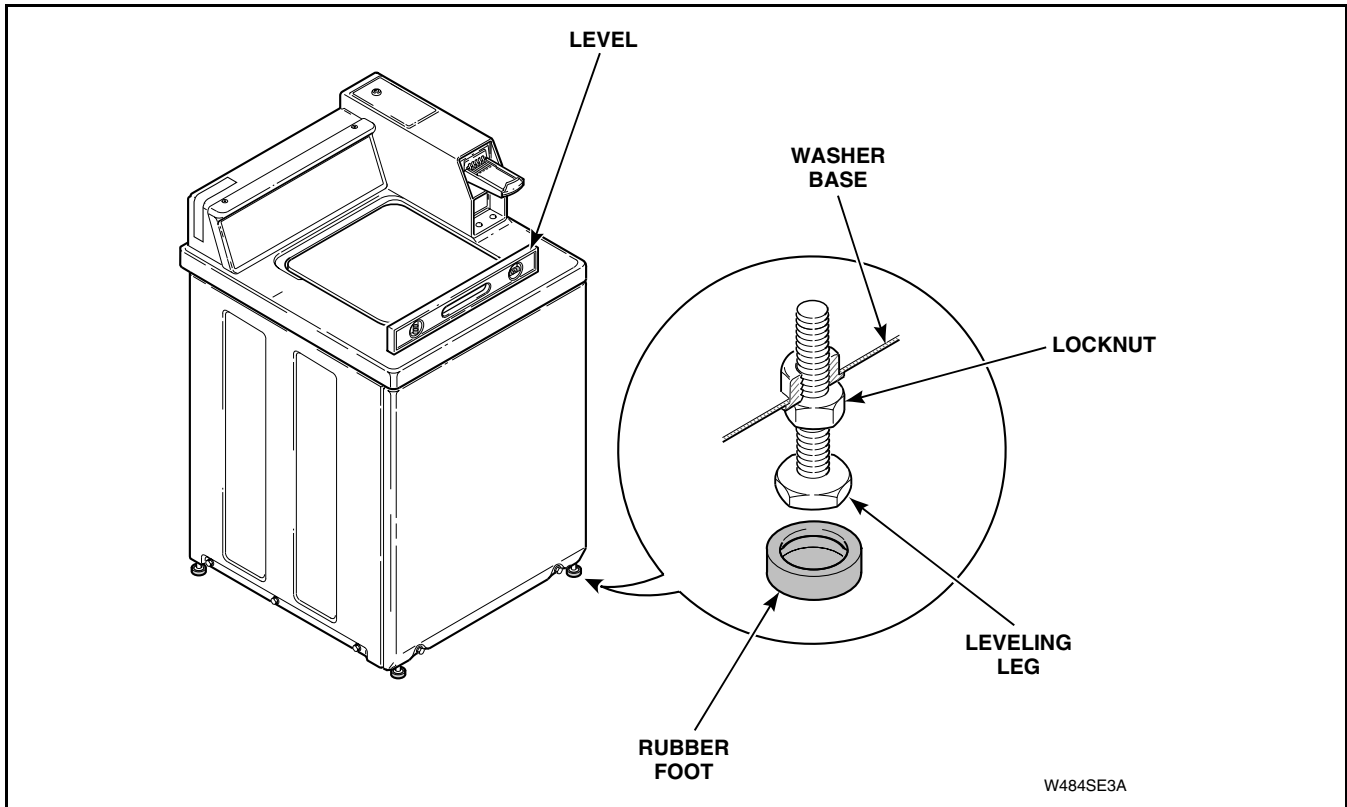



Figure 62

	WARNING
<p>To reduce the risk of electric shock, fire, explosion, serious injury or death:</p> <ul style="list-style-type: none"> • Disconnect electric power to the washer before servicing. • Never start the washer with any guards/panels removed. • Whenever ground wires are removed during servicing, these ground wires must be reconnected to ensure that the washer is properly grounded. 	
W003	

45. PRESSURE SWITCH

Refer to *Figure 63*

The washer is equipped with a variable water level pressure switch (located inside the control hood) which allows the owner to adjust the water fill level height in the washtub from 10, 11 or 13 inches.

IMPORTANT: Water fill heights less than 10 inches are not recommended. When average to large size clothes loads are expected, damage to the clothes and/or the washer may result.

When the washer leaves the factory, the pressure switch is set for approximately 11 inches of water.

To adjust the pressure switch, proceed as follows:

	WARNING
<p>To reduce the risk of electric shock, disconnect the electrical power to the washer before attempting to service.</p>	
W094	

- a. Remove the two control panel attaching screws and lift the assembly up and out of the slots in the cabinet top.
- b. Lay the control panel face down (on protective padding) on top of the washer.
- c. Rotate the cam on the pressure switch **clockwise to lower** the water fill height, or **counterclockwise to raise** the height. Refer to *Figure 63*.

IMPORTANT: The cam has three settings. The setting on the left raises the water level to 10 inches. Middle setting raises the water level to 11 inches. The setting on the right raises the water level to 13 inches.

- d. Carefully reinstall the control panel.
- e. Reconnect the electrical power to the washer.
- f. Run the washer through a cycle and observe the water fill level.

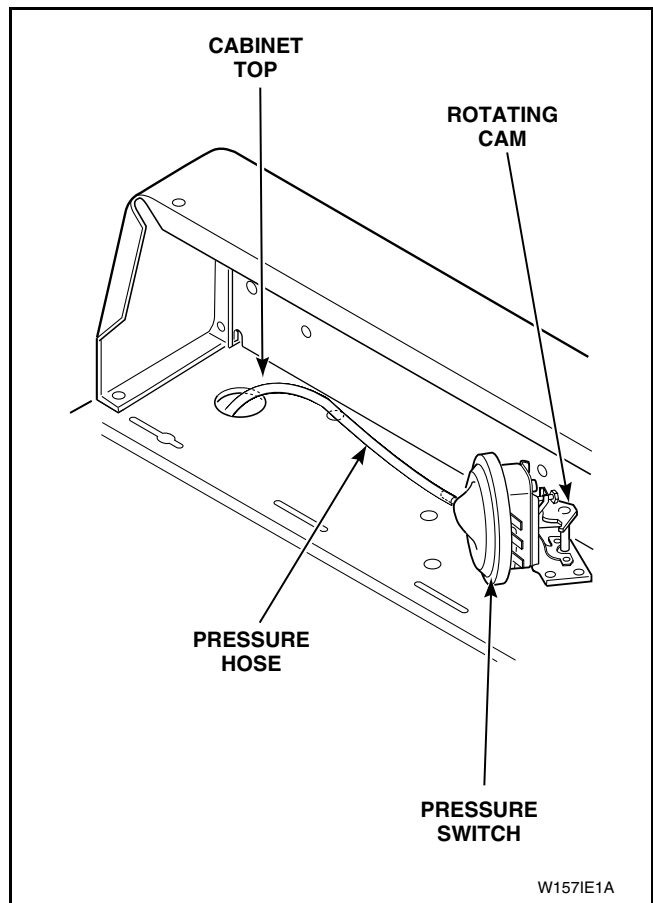



Figure 63

46. BELT (Agitate and Spin)

No belt adjustment is required.

Section 7

Motor Test Procedure

	WARNING
<p>To reduce the risk of electric shock, fire, explosion, serious injury or death:</p> <ul style="list-style-type: none"> • Disconnect electric power to the washer before servicing. • Never start the washer with any guards/panels removed. • Whenever ground wires are removed during servicing, these ground wires must be reconnected to ensure that the washer is properly grounded. 	
<small>W003</small>	

IMPORTANT: Disconnect base wire harness plug from motor.

	WARNING
Disconnect electric power to washer before performing the following steps:	
<small>W188</small>	

Motor test procedures using an Ohm meter.

NOTE: Resistance readings slightly out of given ranges may be due to meter conditions. These readings **DO NOT** necessarily indicate motor failure.

	Meter Connections	Reading Should Be	If Not
1.	Ground to Each Other Terminal	Open	Terminal shorted to ground.
2.	White to Yellow	Closed	Open thermal overload.
3.	Red to Brown	2-8 Ohms	Start winding open or resistance too high or too low.
4.	Blue to White	1-2 Ohms	High speed winding (4 pole) open or resistance too high or too low.
5.	Violet to White (2-speed motor)	2.5 Ohms (approximate)	Low winding open; High speed winding open; or resistance too high or too low.
6.	“R” to Red	Closed	Open start (auxiliary) switch.
7.	“P” to Blue (2-speed motor)	Closed	Open start switch 4 pole winding

NOTE: Steps 8, 9 and 10 are with motor centrifugal mechanism in the run position.

8.	“R” to Red	Open	Start auxiliary switch.
9.	“P” to Blue (2-speed motor)	3 Ohms (approximate)	Refer to Blue to White and Violet to White.
10.	“P” to Violet (2-speed motor)	Closed	Open low (6 pole) winding run switch.

Section 8

Cycle Sequence Charts

FUNCTION		IN USE LIGHT	RINSE LIGHT	SPIN LIGHT	WATER TEMP.	CYCLE & * MOTOR SPEED	TIME (Min. & Sec.)
WASH	WASH, FILL OR AGITATE	X			H, W, C	N = FAST PP = FAST D = SLOW	10:33
	PAUSE	X					:05
SPIN	SPIN	X		X		N = FAST PP = FAST D = SLOW	1:56
	SPIN AND SPRAY	X		X	COLD	N = FAST PP = FAST D = SLOW	:31
	SPIN	X		X		N = FAST PP = FAST D = SLOW	:36
	SPIN AND SPRAY	X		X	COLD	N = FAST PP = FAST D = SLOW	:07
	SPIN	X		X		N = FAST PP = FAST D = SLOW	1:07
PAUSE		X					:04
RINSE	RINSE FILL (Timer Motor Runs)	X	X		COLD		:36
	PAUSE OR FILL	X	X		COLD		:02
	RINSE, AGITATE OR FILL	X	X		COLD	N = FAST PP = FAST D = SLOW	3:03
PAUSE		X					:06
SPIN	SPIN	X		X		N = FAST PP = FAST D = SLOW	10:32
TIMER MOTOR RUNS OUT							:42
TOTAL							30:00

KEY:

H = HOT	PP = PERMANENT PRESS CYCLE
W = WARM	D = DELICATE CYCLE
C = COLD	X = INDICATOR LIGHT GLOWS
N = NORMAL CYCLE	

TIMER NO. 28716 CYCLE SEQUENCE

Section 8 Cycle Sequence Charts

FUNCTION		IN USE LIGHT	RINSE LIGHT	SPIN LIGHT	WATER TEMP.	CYCLE & * MOTOR SPEED	EATON TIME (Min. & Sec.)	MALLORY TIME (Min. & Sec.)
WASH	COIN SLIDE STARTING STROKE 17.82° (Mallory) 16.84° (Eaton)	X			H, W, C	N = FAST PP = FAST D = SLOW	:57	1:00
	AGITATE OR VARIABLE FILL	X			H, W, C	N = FAST PP = FAST D = SLOW	7:00	7:00
PAUSE		X					:21	:21
SPIN	SPIN	X				N = FAST PP = FAST D = SLOW	1:25	1:25
	SPIN AND SPRAY	X			COLD	N = FAST PP = FAST D = SLOW	:45	:45
	SPIN	X				N = FAST PP = FAST D = SLOW	1:15	1:15
PAUSE		X					:04	:04
RINSE	FILL (Timer Motor Runs)	X			COLD		:13	:19
	PAUSE OR FILL	X	X		COLD		:13	:13
	AGITATE OR VARIABLE FILL	X	X		COLD	N = FAST PP = FAST D = SLOW	1:01	:54
X				:09		:16		
PAUSE		X					:14	:16
		X		X			:06	:03
SPIN	SPIN	X		X		N = FAST PP = FAST D = SLOW	6:00	6:00
PAUSE		X		X			:04	:08
		X					:06	:03
OFF							:22	:19
TOTAL							20:17	20:21

KEY:

H = HOT
W = WARM
C = COLD
N = NORMAL CYCLE
PP = PERMANENT PRESS CYCLE
D = DELICATE CYCLE
X = INDICATOR LIGHT GLOWS

TIMER NO. 31111P CYCLE SEQUENCE

Section 8 Cycle Sequence Charts

FUNCTION		IN USE LIGHT	RINSE LIGHT	SPIN LIGHT	WATER TEMP.	CYCLE & * MOTOR SPEED	TIME (Min. & Sec.)
WASH	COIN SLIDE STARTING STROKE 16.84° (Eaton)	X			H, W, C	N = FAST PP = FAST D = SLOW	1:23
	AGITATE OR VARIABLE FILL	X			H, W, C	N = FAST PP = FAST D = SLOW	10:00
PAUSE		X					:34
SPIN	SPIN	X				N = FAST PP = FAST D = SLOW	1:32
	SPIN AND SPRAY	X			COLD	N = FAST PP = FAST D = SLOW	:30
	SPIN	X				N = FAST PP = FAST D = SLOW	1:29
PAUSE		X					:06
RINSE	FILL (Timer Motor Runs)	X			COLD		:06
	PAUSE OR FILL	X	X		COLD		:20
	AGITATE OR VARIABLE FILL			X		COLD	N = FAST PP = FAST D = SLOW
X					D = SLOW		:23
PAUSE		X					:24
		X		X			:10
SPIN	SPIN	X		X		N = FAST PP = FAST D = SLOW	8:30
PAUSE		X		X			:06
		X					:13
OFF							:32
TOTAL							29:39

KEY:

H = HOT **PP = PERMANENT PRESS CYCLE**
W = WARM **D = DELICATE CYCLE**
C = COLD **X = INDICATOR LIGHT GLOWS**
N = NORMAL CYCLE

TIMER NO. 34601P CYCLE SEQUENCE

Section 8 Cycle Sequence Charts

FUNCTION		IN USE LIGHT	RINSE LIGHT	SPIN LIGHT	WATER TEMP.	CYCLE & * MOTOR SPEED	EATON TIME (Min. & Sec.)	MALLORY TIME (Min. & Sec.)
WASH	COIN SLIDE STARTING STROKE 17.82° (Mallory) 16.84° (Eaton)	X			H, W, C	N = FAST PP = FAST D = SLOW	1:23	1:31
	AGITATE OR VARIABLE FILL	X			H, W, C	N = FAST PP = FAST D = SLOW	10:00	10:00
PAUSE		X					:34	:34
SPIN	SPIN	X				N = FAST PP = FAST D = SLOW	1:32	1:32
	SPIN AND SPRAY	X			COLD	N = FAST PP = FAST D = SLOW	:30	:30
	SPIN	X				N = FAST PP = FAST D = SLOW	1:29	1:30
PAUSE		X					:06	:06
RINSE	FILL (Timer Motor Runs)	X			COLD		:06	:34
	PAUSE OR FILL	X	X		COLD		:20	:20
	AGITATE OR VARIABLE FILL	X	X		COLD	N = FAST PP = FAST D = SLOW	3:19	3:20
		X				D = SLOW	:24	:23
PAUSE		X					:24	:25
		X		X			:10	:11
SPIN	SPIN	X		X		N = FAST PP = FAST D = SLOW	8:30	8:30
PAUSE		X		X			:06	:18
		X					:13	:05
OFF							:32	:28
TOTAL							29:39	30:17

KEY:

H = HOT **PP = PERMANENT PRESS CYCLE**
W = WARM **D = DELICATE CYCLE**
C = COLD **X = INDICATOR LIGHT GLOWS**
N = NORMAL CYCLE

TIMER NO. 34602 CYCLE SEQUENCE

Section 9

Internal Wiring of Washer Motor Switch



WARNING

To reduce the risk of electric shock, fire, explosion, serious injury or death:

- Disconnect electric power to the washer before servicing.
- Never start the washer with any guards/panels removed.
- Whenever ground wires are removed during servicing, these ground wires must be reconnected to ensure that the washer is properly grounded.

W003

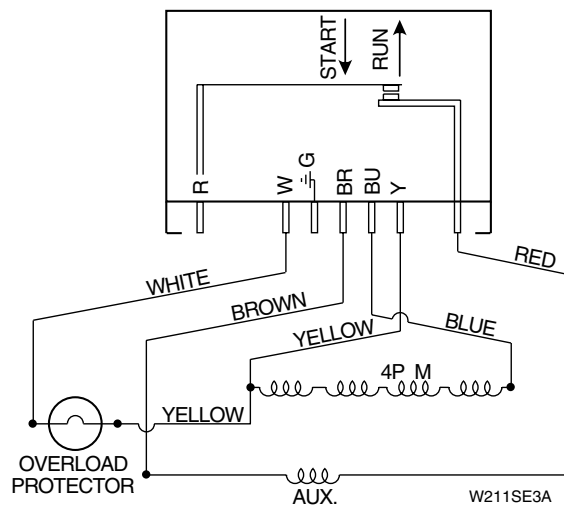
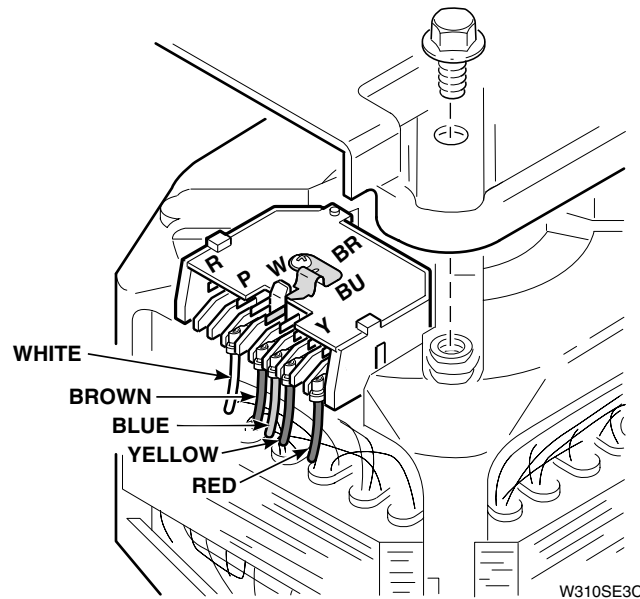

**MOTOR ASSEMBLY
(1 SPEED MOTORS)**



WARNING

To reduce the risk of electric shock, fire, explosion, serious injury or death:

- Disconnect electric power to the washer before servicing.
- Never start the washer with any guards/panels removed.
- Whenever ground wires are removed during servicing, these ground wires must be reconnected to ensure that the washer is properly grounded.

W003

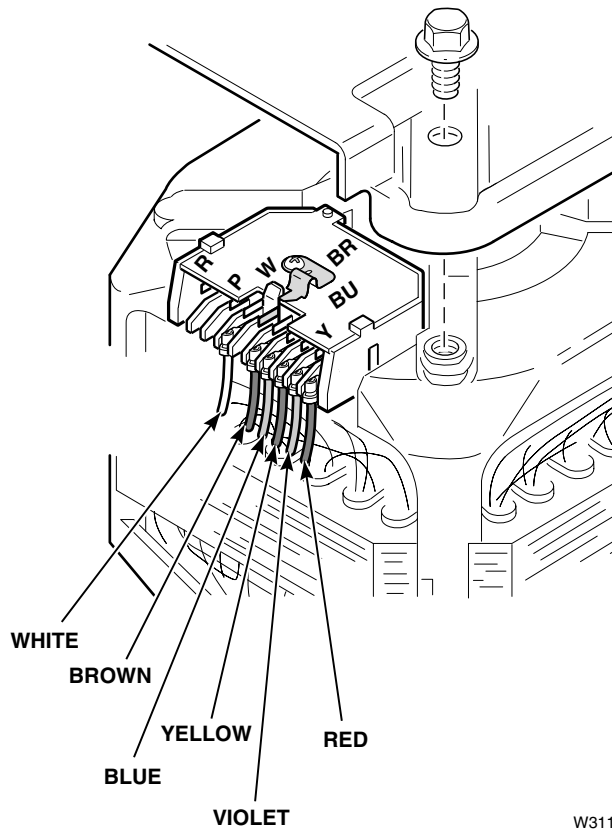

W311SE3D

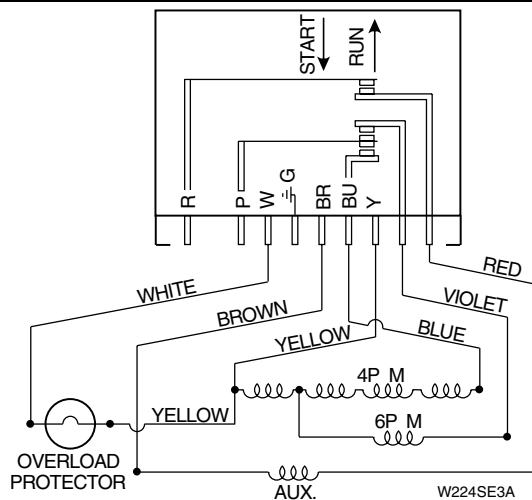

W224SE3A

MOTOR ASSEMBLY (2 SPEED MOTORS)

Section 10

Wiring Diagrams



WARNING

Failure to install, maintain, and/or operate this machine according to the manufacturer's instructions may result in conditions which can produce bodily injury and/or property damage.

W030

WIRING DIAGRAMS AND SCHEMATICS
FOUND ON THE FOLLOWING PAGES
ARE FOR MODELS COVERED IN THIS MANUAL.



WARNING

Failure to install, maintain, and/or operate this machine according to the manufacturer's instructions may result in conditions which can produce bodily injury and/or property damage.

W030

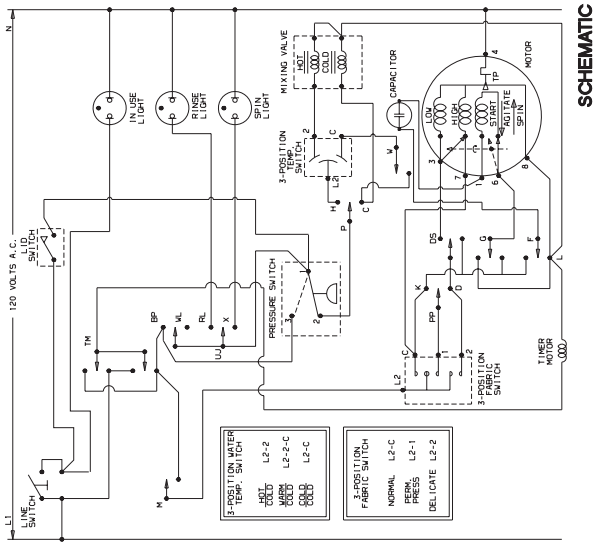

SCHEMATIC

WARNING
 Failure to install, maintain, and/or operate this machine according to the manufacturer's instructions may result in conditions which can produce bodily injury and/or property damage.

THIS MACHINE MANUFACTURED UNDER ONE OR MORE OF THE FOLLOWING PATENTS:
 UNITED STATES NO. 3,888,755;
 CANADIAN NO. 1,008,285;
 994,685
 OTHER PATENTS PENDING

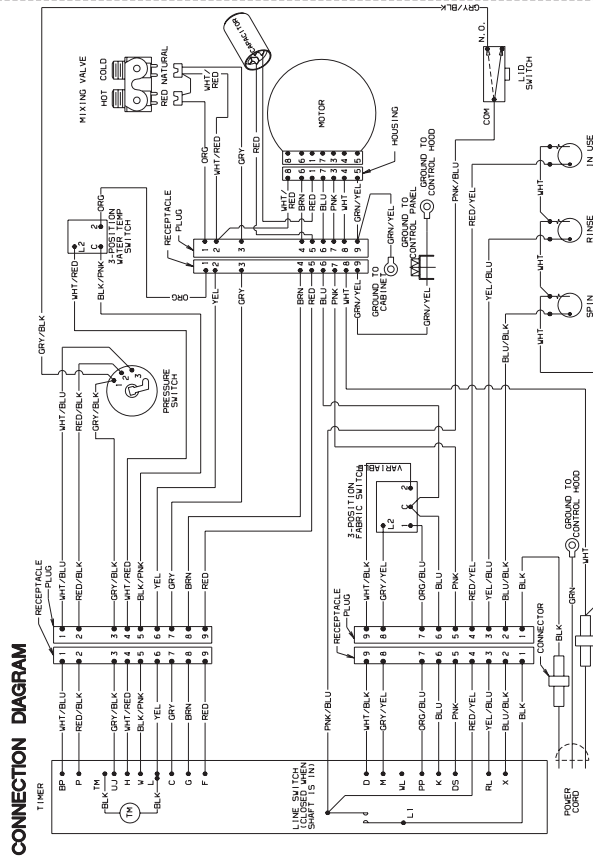

CONNECTION DIAGRAM

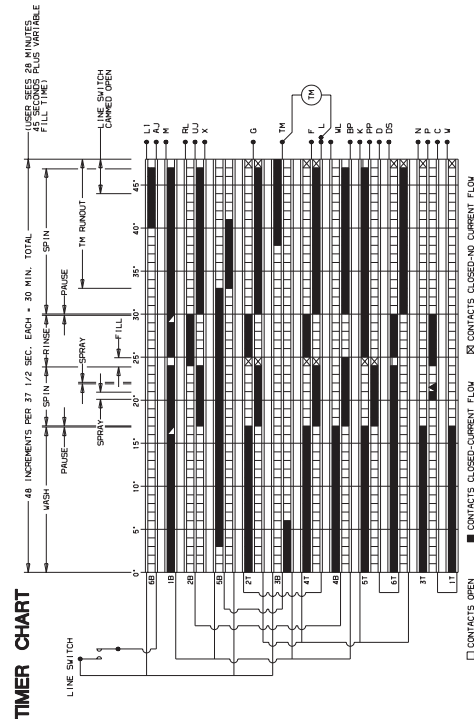

TIMER CHART

MODELS HWT020*A, HWT020*C, HWT020*M, SWT020*A, SWT020*M, SWT021*A, SWT021*M, UWT021*A AND UWT021*M



WARNING

Failure to install, maintain, and/or operate this machine according to the manufacturer's instructions may result in conditions which can produce bodily injury and/or property damage.

W030

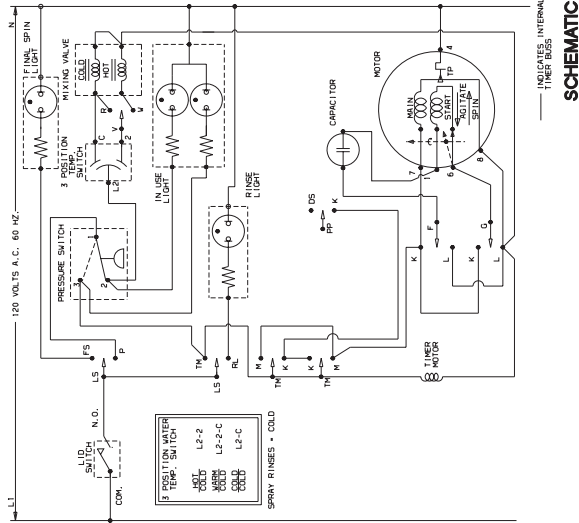

WARNING
 Failure to install, maintain, and/or operate this machine according to the manufacturer's instructions may result in conditions which can produce bodily injury and/or property damage.

THIS MACHINE MANUFACTURED BY ALLIANCE LAUNDRY SYSTEMS, INC. OF THE UNITED STATES INC. 3, 281, 874; 994, 585; 1, 008, 285; 994, 585; 1, 008, 285; OTHER PATENTS PENDING.

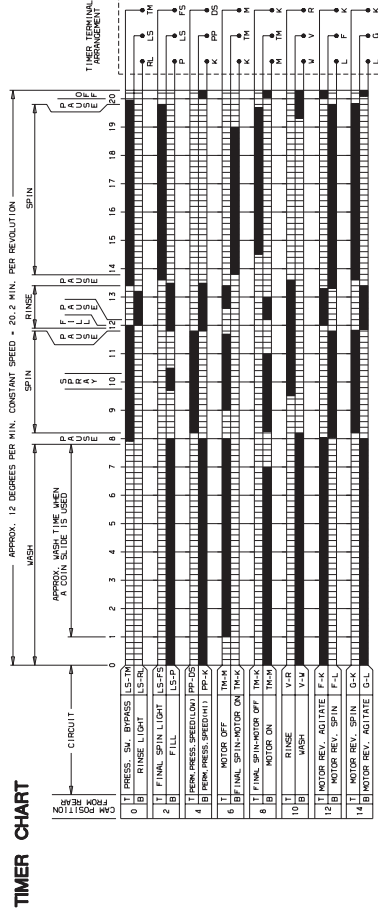
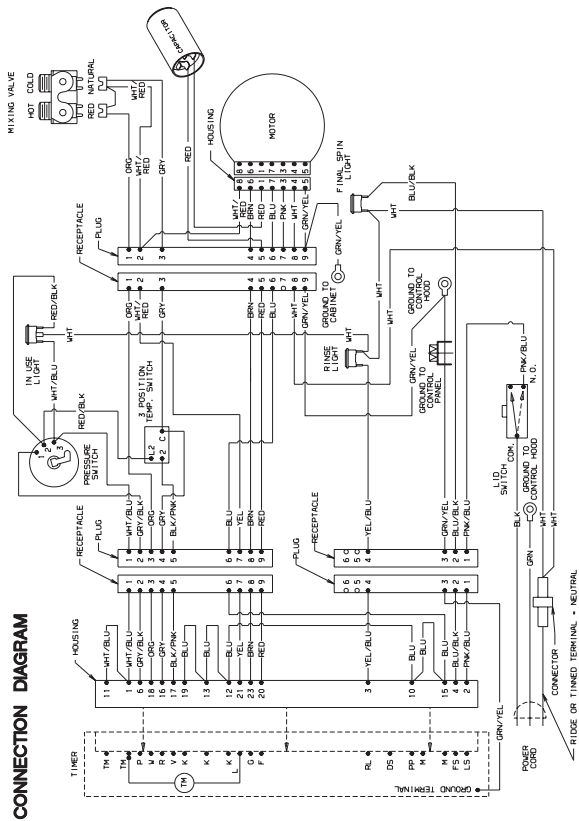

MODELS HWT110*A, HWT110*C, HWT110*M, SWT110*A, SWT110*M, SWT111*A AND SWT111*M



WARNING

Failure to install, maintain, and/or operate this machine according to the manufacturer's instructions may result in conditions which can produce bodily injury and/or property damage.

W030

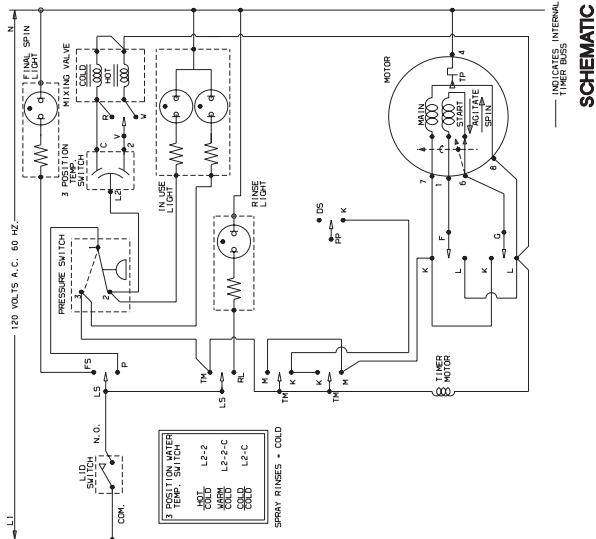

WARNING
Failure to install, maintain, and/or operate this machine according to manufacturer's instructions may result in conditions which can produce bodily injury and/or property damage.

THIS MACHINE MANUFACTURED BY ALLIANCE LAUNDRY SYSTEMS, INC. OF THE UNITED STATES NO. 3,253,574; 3,253,575; 3,253,576; 3,253,577; 3,253,578; 3,253,579; 3,253,580; 3,253,581; 3,253,582; 3,253,583; 3,253,584; 3,253,585; 3,253,586; 3,253,587; 3,253,588; 3,253,589; 3,253,590; 3,253,591; 3,253,592; 3,253,593; 3,253,594; 3,253,595; 3,253,596; 3,253,597; 3,253,598; 3,253,599; 3,253,600; 3,253,601; 3,253,602; 3,253,603; 3,253,604; 3,253,605; 3,253,606; 3,253,607; 3,253,608; 3,253,609; 3,253,610; 3,253,611; 3,253,612; 3,253,613; 3,253,614; 3,253,615; 3,253,616; 3,253,617; 3,253,618; 3,253,619; 3,253,620; 3,253,621; 3,253,622; 3,253,623; 3,253,624; 3,253,625; 3,253,626; 3,253,627; 3,253,628; 3,253,629; 3,253,630; 3,253,631; 3,253,632; 3,253,633; 3,253,634; 3,253,635; 3,253,636; 3,253,637; 3,253,638; 3,253,639; 3,253,640; 3,253,641; 3,253,642; 3,253,643; 3,253,644; 3,253,645; 3,253,646; 3,253,647; 3,253,648; 3,253,649; 3,253,650; 3,253,651; 3,253,652; 3,253,653; 3,253,654; 3,253,655; 3,253,656; 3,253,657; 3,253,658; 3,253,659; 3,253,660; 3,253,661; 3,253,662; 3,253,663; 3,253,664; 3,253,665; 3,253,666; 3,253,667; 3,253,668; 3,253,669; 3,253,670; 3,253,671; 3,253,672; 3,253,673; 3,253,674; 3,253,675; 3,253,676; 3,253,677; 3,253,678; 3,253,679; 3,253,680; 3,253,681; 3,253,682; 3,253,683; 3,253,684; 3,253,685; 3,253,686; 3,253,687; 3,253,688; 3,253,689; 3,253,690; 3,253,691; 3,253,692; 3,253,693; 3,253,694; 3,253,695; 3,253,696; 3,253,697; 3,253,698; 3,253,699; 3,253,700; 3,253,701; 3,253,702; 3,253,703; 3,253,704; 3,253,705; 3,253,706; 3,253,707; 3,253,708; 3,253,709; 3,253,710; 3,253,711; 3,253,712; 3,253,713; 3,253,714; 3,253,715; 3,253,716; 3,253,717; 3,253,718; 3,253,719; 3,253,720; 3,253,721; 3,253,722; 3,253,723; 3,253,724; 3,253,725; 3,253,726; 3,253,727; 3,253,728; 3,253,729; 3,253,730; 3,253,731; 3,253,732; 3,253,733; 3,253,734; 3,253,735; 3,253,736; 3,253,737; 3,253,738; 3,253,739; 3,253,740; 3,253,741; 3,253,742; 3,253,743; 3,253,744; 3,253,745; 3,253,746; 3,253,747; 3,253,748; 3,253,749; 3,253,750; 3,253,751; 3,253,752; 3,253,753; 3,253,754; 3,253,755; 3,253,756; 3,253,757; 3,253,758; 3,253,759; 3,253,760; 3,253,761; 3,253,762; 3,253,763; 3,253,764; 3,253,765; 3,253,766; 3,253,767; 3,253,768; 3,253,769; 3,253,770; 3,253,771; 3,253,772; 3,253,773; 3,253,774; 3,253,775; 3,253,776; 3,253,777; 3,253,778; 3,253,779; 3,253,780; 3,253,781; 3,253,782; 3,253,783; 3,253,784; 3,253,785; 3,253,786; 3,253,787; 3,253,788; 3,253,789; 3,253,790; 3,253,791; 3,253,792; 3,253,793; 3,253,794; 3,253,795; 3,253,796; 3,253,797; 3,253,798; 3,253,799; 3,253,800; 3,253,801; 3,253,802; 3,253,803; 3,253,804; 3,253,805; 3,253,806; 3,253,807; 3,253,808; 3,253,809; 3,253,810; 3,253,811; 3,253,812; 3,253,813; 3,253,814; 3,253,815; 3,253,816; 3,253,817; 3,253,818; 3,253,819; 3,253,820; 3,253,821; 3,253,822; 3,253,823; 3,253,824; 3,253,825; 3,253,826; 3,253,827; 3,253,828; 3,253,829; 3,253,830; 3,253,831; 3,253,832; 3,253,833; 3,253,834; 3,253,835; 3,253,836; 3,253,837; 3,253,838; 3,253,839; 3,253,840; 3,253,841; 3,253,842; 3,253,843; 3,253,844; 3,253,845; 3,253,846; 3,253,847; 3,253,848; 3,253,849; 3,253,850; 3,253,851; 3,253,852; 3,253,853; 3,253,854; 3,253,855; 3,253,856; 3,253,857; 3,253,858; 3,253,859; 3,253,860; 3,253,861; 3,253,862; 3,253,863; 3,253,864; 3,253,865; 3,253,866; 3,253,867; 3,253,868; 3,253,869; 3,253,870; 3,253,871; 3,253,872; 3,253,873; 3,253,874; 3,253,875; 3,253,876; 3,253,877; 3,253,878; 3,253,879; 3,253,880; 3,253,881; 3,253,882; 3,253,883; 3,253,884; 3,253,885; 3,253,886; 3,253,887; 3,253,888; 3,253,889; 3,253,890; 3,253,891; 3,253,892; 3,253,893; 3,253,894; 3,253,895; 3,253,896; 3,253,897; 3,253,898; 3,253,899; 3,253,900; 3,253,901; 3,253,902; 3,253,903; 3,253,904; 3,253,905; 3,253,906; 3,253,907; 3,253,908; 3,253,909; 3,253,910; 3,253,911; 3,253,912; 3,253,913; 3,253,914; 3,253,915; 3,253,916; 3,253,917; 3,253,918; 3,253,919; 3,253,920; 3,253,921; 3,253,922; 3,253,923; 3,253,924; 3,253,925; 3,253,926; 3,253,927; 3,253,928; 3,253,929; 3,253,930; 3,253,931; 3,253,932; 3,253,933; 3,253,934; 3,253,935; 3,253,936; 3,253,937; 3,253,938; 3,253,939; 3,253,940; 3,253,941; 3,253,942; 3,253,943; 3,253,944; 3,253,945; 3,253,946; 3,253,947; 3,253,948; 3,253,949; 3,253,950; 3,253,951; 3,253,952; 3,253,953; 3,253,954; 3,253,955; 3,253,956; 3,253,957; 3,253,958; 3,253,959; 3,253,960; 3,253,961; 3,253,962; 3,253,963; 3,253,964; 3,253,965; 3,253,966; 3,253,967; 3,253,968; 3,253,969; 3,253,970; 3,253,971; 3,253,972; 3,253,973; 3,253,974; 3,253,975; 3,253,976; 3,253,977; 3,253,978; 3,253,979; 3,253,980; 3,253,981; 3,253,982; 3,253,983; 3,253,984; 3,253,985; 3,253,986; 3,253,987; 3,253,988; 3,253,989; 3,253,990; 3,253,991; 3,253,992; 3,253,993; 3,253,994; 3,253,995; 3,253,996; 3,253,997; 3,253,998; 3,253,999; 3,253,1000.

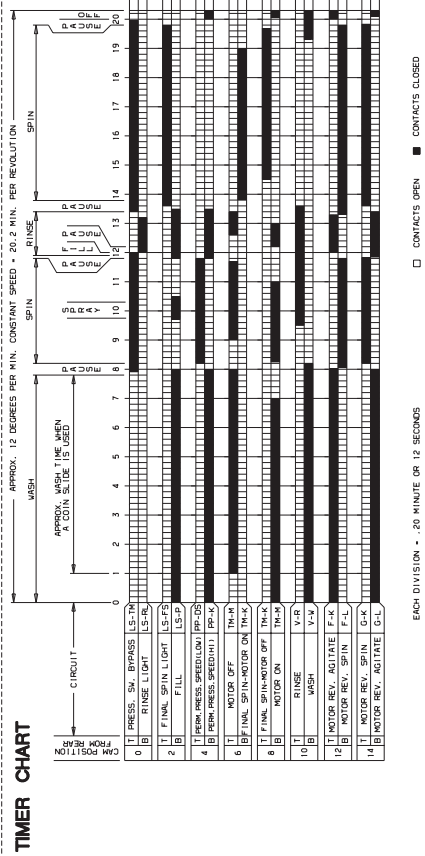
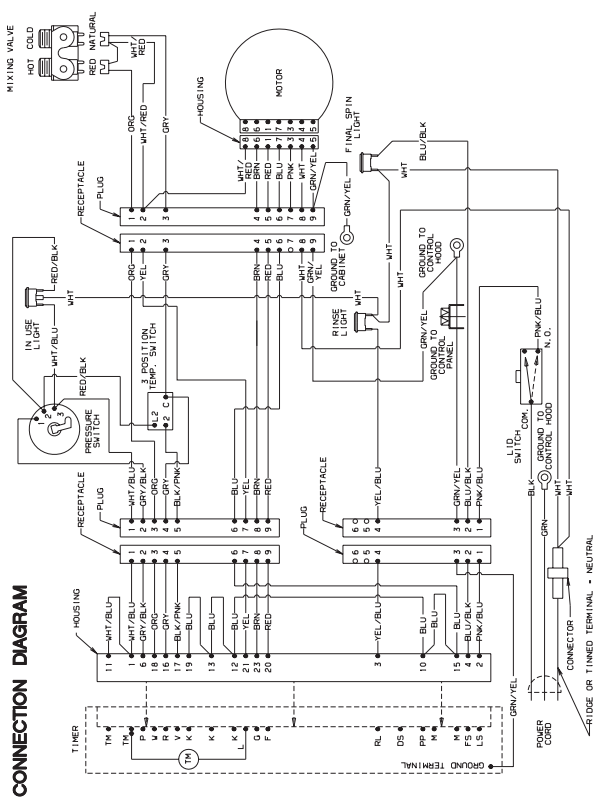

MODELS JWT110*A AND JWT110*M



WARNING

Failure to install, maintain, and/or operate this machine according to the manufacturer's instructions may result in conditions which can produce bodily injury and/or property damage.

W030

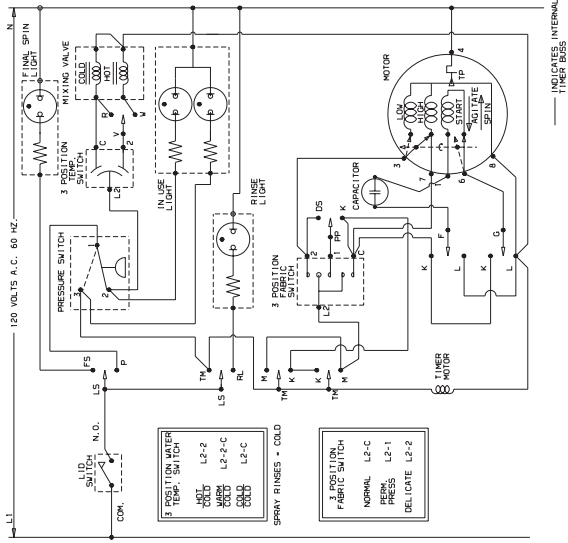

INDICATES INTERNAL WIRING SCHEMATIC

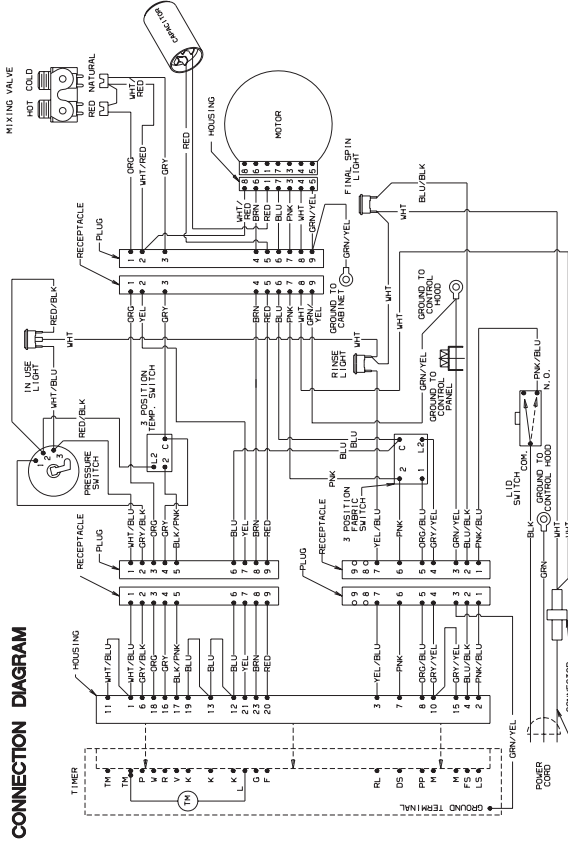

CONNECTION DIAGRAM

WARNING
Failure to install, maintain, and/or operate this machine according to the manufacturer's instructions may result in conditions which can produce bodily injury and/or property damage.

THIS MACHINE MANUFACTURED UNDER ONE OR MORE OF THE FOLLOWING PATENTS: 3,253,874; 3,838,755; 3,445,642 (U.S.); 1,098,855 (CANADIAN NO. 1,098,855); OTHER PATENTS PENDING.

MATING HOUSING WIRE POSITION

3	YEL	BLU	BLU	BLU
4	PNK	BLU	BLU	BLU
5	BLK	BLU	BLU	BLU
6	BLK	BLU	BLU	BLU
7	BLU	BLU	BLU	BLU
8	BLU	BLU	BLU	BLU
9	BLU	BLU	BLU	BLU
10	BLU	BLU	BLU	BLU
11	BLU	BLU	BLU	BLU
12	BLU	BLU	BLU	BLU
13	BLU	BLU	BLU	BLU
14	BLU	BLU	BLU	BLU
15	BLU	BLU	BLU	BLU
16	BLU	BLU	BLU	BLU
17	BLU	BLU	BLU	BLU
18	BLU	BLU	BLU	BLU
19	BLU	BLU	BLU	BLU
20	BLU	BLU	BLU	BLU
21	BLU	BLU	BLU	BLU
22	BLU	BLU	BLU	BLU
23	BLU	BLU	BLU	BLU
24	BLU	BLU	BLU	BLU
25	BLU	BLU	BLU	BLU
26	BLU	BLU	BLU	BLU
27	BLU	BLU	BLU	BLU
28	BLU	BLU	BLU	BLU
29	BLU	BLU	BLU	BLU
30	BLU	BLU	BLU	BLU
31	BLU	BLU	BLU	BLU
32	BLU	BLU	BLU	BLU
33	BLU	BLU	BLU	BLU
34	BLU	BLU	BLU	BLU
35	BLU	BLU	BLU	BLU
36	BLU	BLU	BLU	BLU
37	BLU	BLU	BLU	BLU
38	BLU	BLU	BLU	BLU
39	BLU	BLU	BLU	BLU
40	BLU	BLU	BLU	BLU
41	BLU	BLU	BLU	BLU
42	BLU	BLU	BLU	BLU
43	BLU	BLU	BLU	BLU
44	BLU	BLU	BLU	BLU
45	BLU	BLU	BLU	BLU
46	BLU	BLU	BLU	BLU
47	BLU	BLU	BLU	BLU
48	BLU	BLU	BLU	BLU
49	BLU	BLU	BLU	BLU
50	BLU	BLU	BLU	BLU
51	BLU	BLU	BLU	BLU
52	BLU	BLU	BLU	BLU
53	BLU	BLU	BLU	BLU
54	BLU	BLU	BLU	BLU
55	BLU	BLU	BLU	BLU
56	BLU	BLU	BLU	BLU
57	BLU	BLU	BLU	BLU
58	BLU	BLU	BLU	BLU
59	BLU	BLU	BLU	BLU
60	BLU	BLU	BLU	BLU

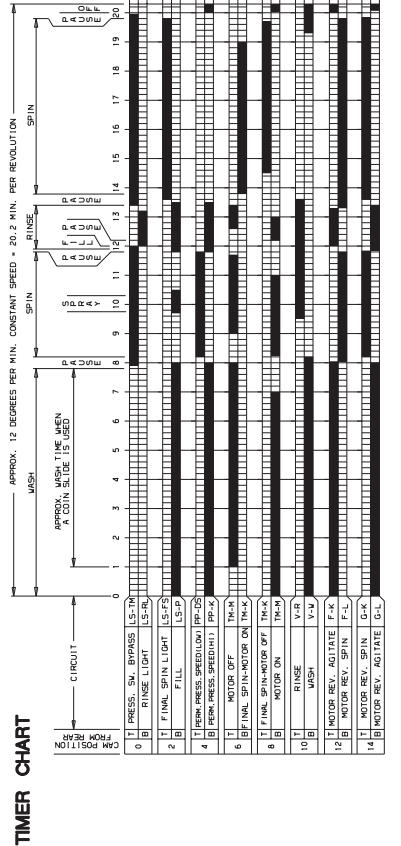

TIMER CHART

MODELS HWT120*A, HWT120*C, HWT120*M, SWT120*A, SWT120*M, SWT121*A AND SWT121*M



WARNING

Failure to install, maintain, and/or operate this machine according to the manufacturer's instructions may result in conditions which can produce bodily injury and/or property damage.

W030

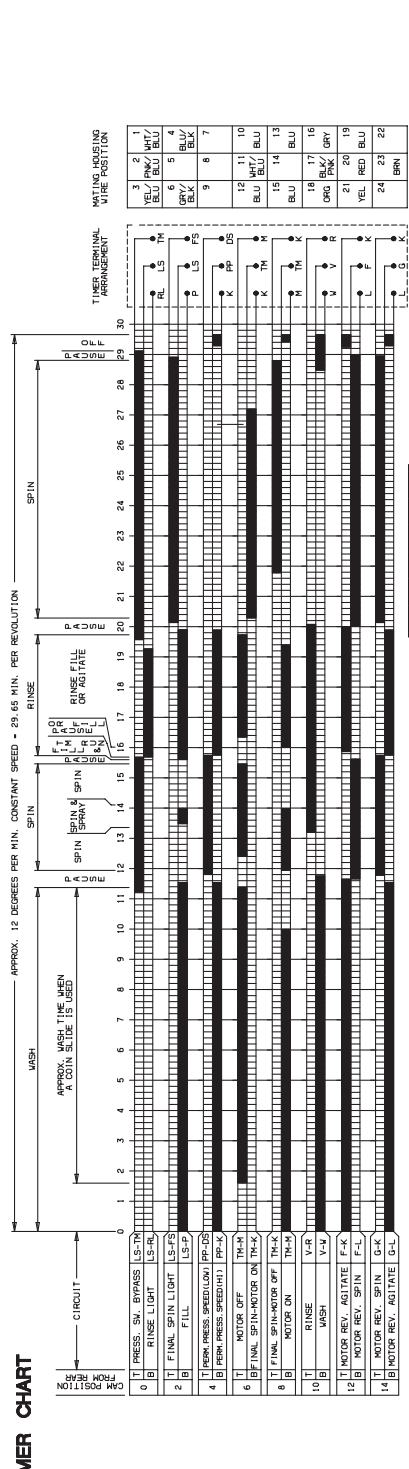
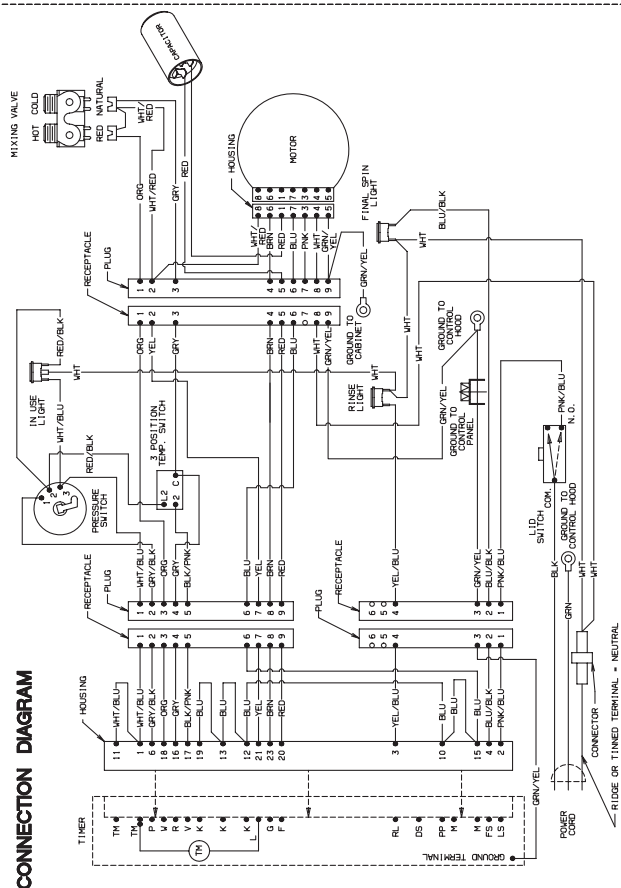
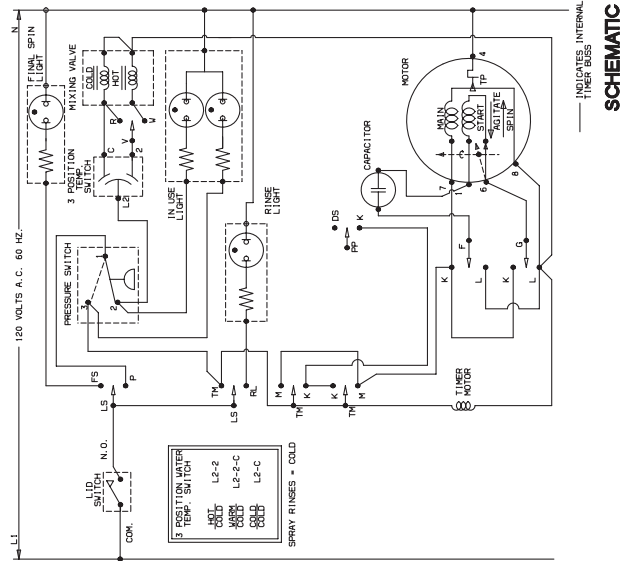

WARNING
THIS MACHINE MANUFACTURED UNDER THE PATENT OF THE UNITED STATES NO. 3,253,674; 3,889,795; 3,445,642 AND FOREIGN PATENTS. INSTRUCTIONS MAY RESULT IN BODILY INJURY AND/OR PROPERTY DAMAGE.
OTHER PATENTS PENDING

MODELS SWT210*A AND SWT210*M



WARNING

Failure to install, maintain, and/or operate this machine according to the manufacturer's instructions may result in conditions which can produce bodily injury and/or property damage.

W030

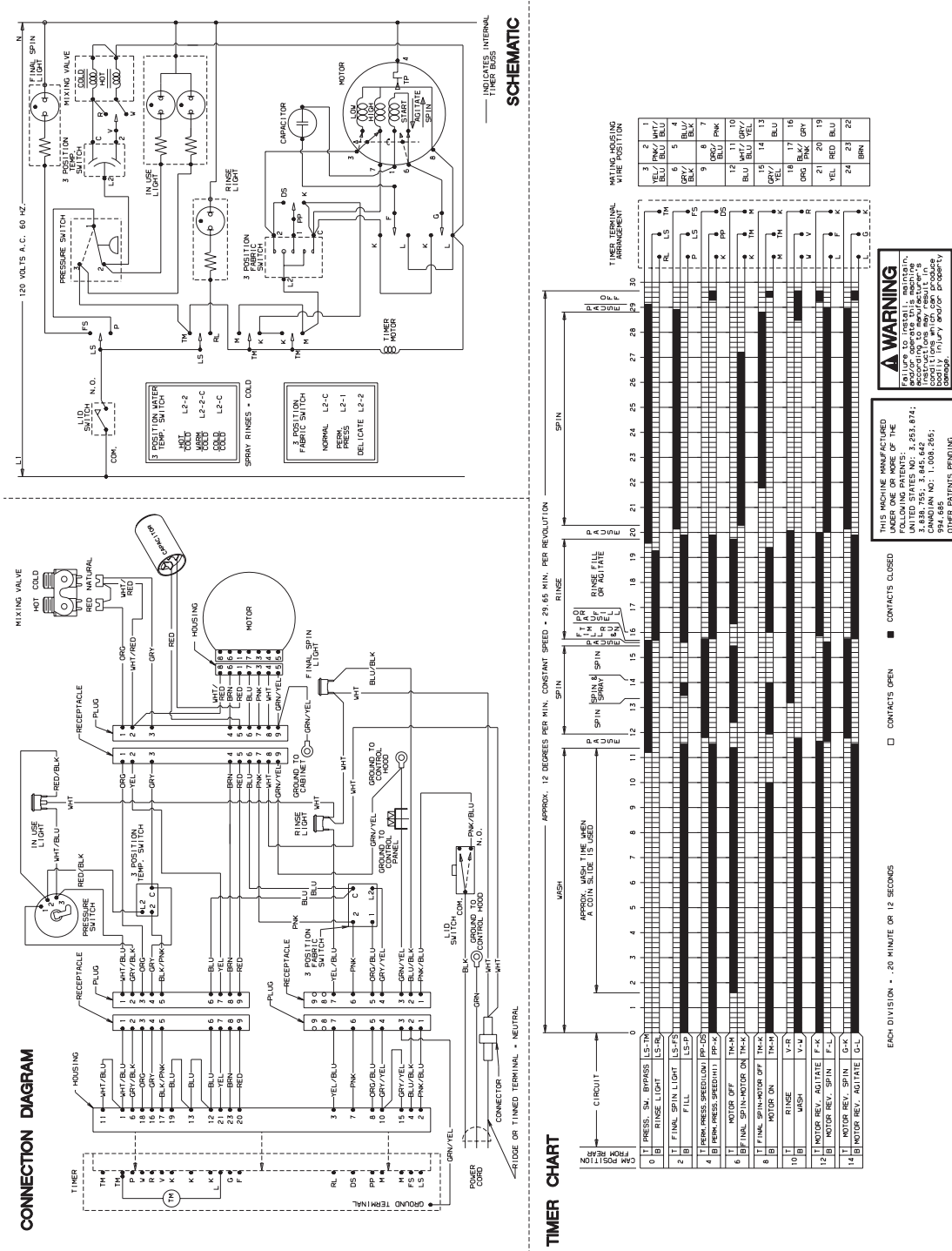

WARNING
 THIS MACHINE WAS DESIGNED AND MANUFACTURED IN ACCORDANCE WITH THE REQUIREMENTS OF THE NATIONAL ELECTRICAL CODE (NEC) AND THE CANADIAN ELECTRICAL CODE (CEC).
 UNITED STATES PATENT NO. 3,251,874;
 CANADIAN PATENT NO. 1,008,265;
 994,685
 OTHER PATENTS PENDING.

MODELS SWT220*A, SWT220*M, SWT221*A AND SWT221*M



WARNING

Failure to install, maintain, and/or operate this machine according to the manufacturer's instructions may result in conditions which can produce bodily injury and/or property damage.

W030

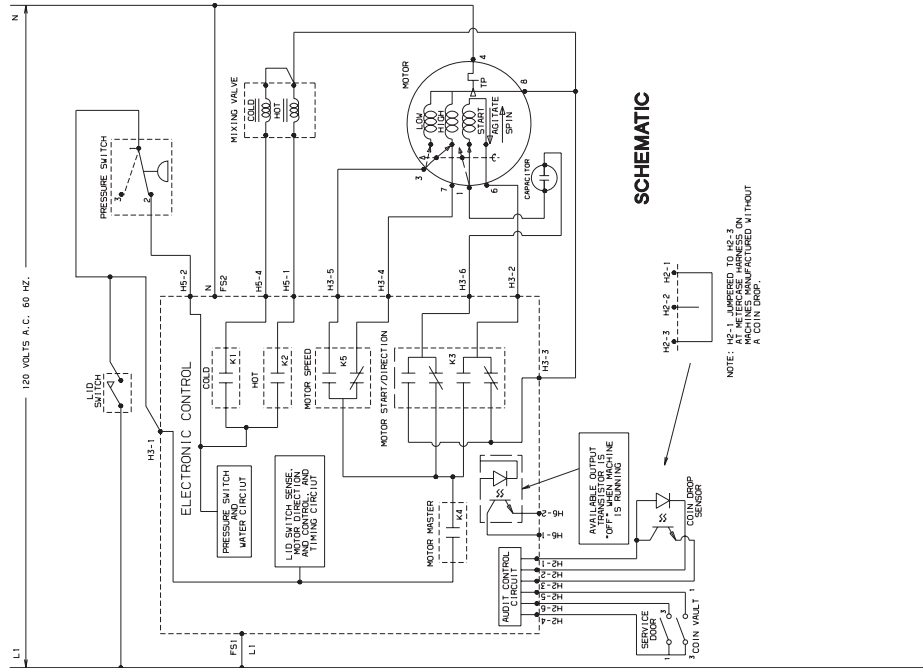

SCHEMATIC

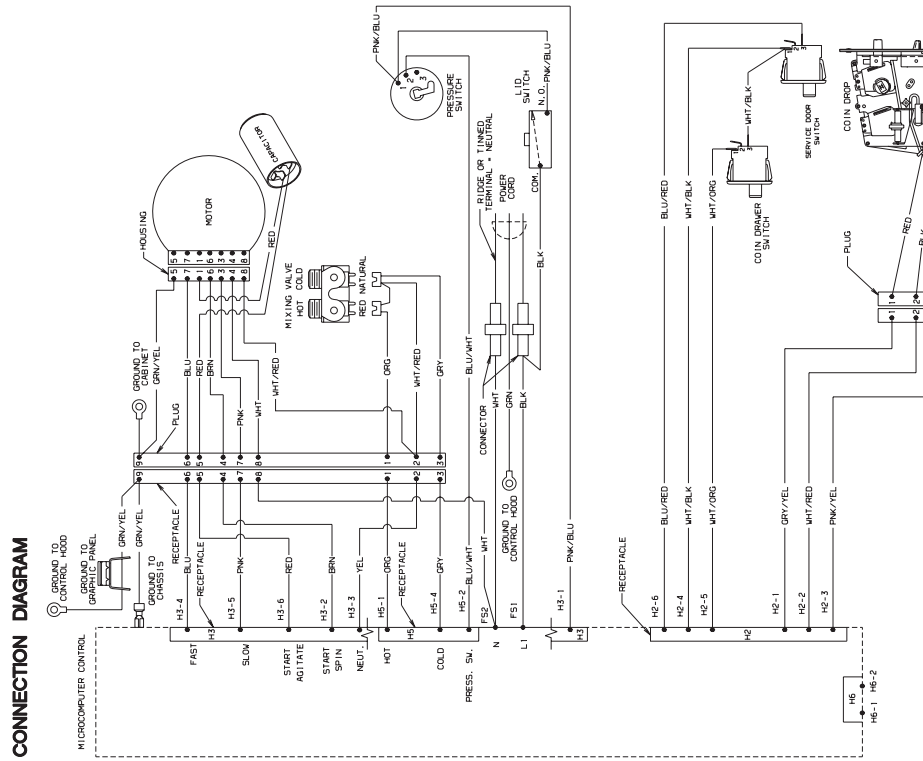

CONNECTION DIAGRAM

THIS MACHINE MANUFACTURED BY THE FOLLOWING PATENTS: UNITED STATES NO. 3,253,874; CANADA NO. 1,199,845; 994,685 OTHER PATENTS PENDING.

WARNING
FAILURE TO INSTALL, MAINTAIN AND/OR OPERATE THIS MACHINE ACCORDING TO THE MANUFACTURER'S INSTRUCTIONS MAY RESULT IN BODILY INJURY AND/OR PROPERTY DAMAGE.

NOTE
POWER SUPPLY WIRING MUST HAVE CORRECT POLARITY AND GROUNDING FOR THE UNIT TO OPERATE CORRECTLY.

MODELS SWT420*A, SWT420*D, SWT420*M, SWT421*A, SWT421*D, SWT421*M, SWT520*A, SWT520*M, SWT521*A, SWT521*M, SWT620*M, SWT621*M, SWT720*M AND SWT721*M



WARNING

Failure to install, maintain, and/or operate this machine according to the manufacturer's instructions may result in conditions which can produce bodily injury and/or property damage.

W030

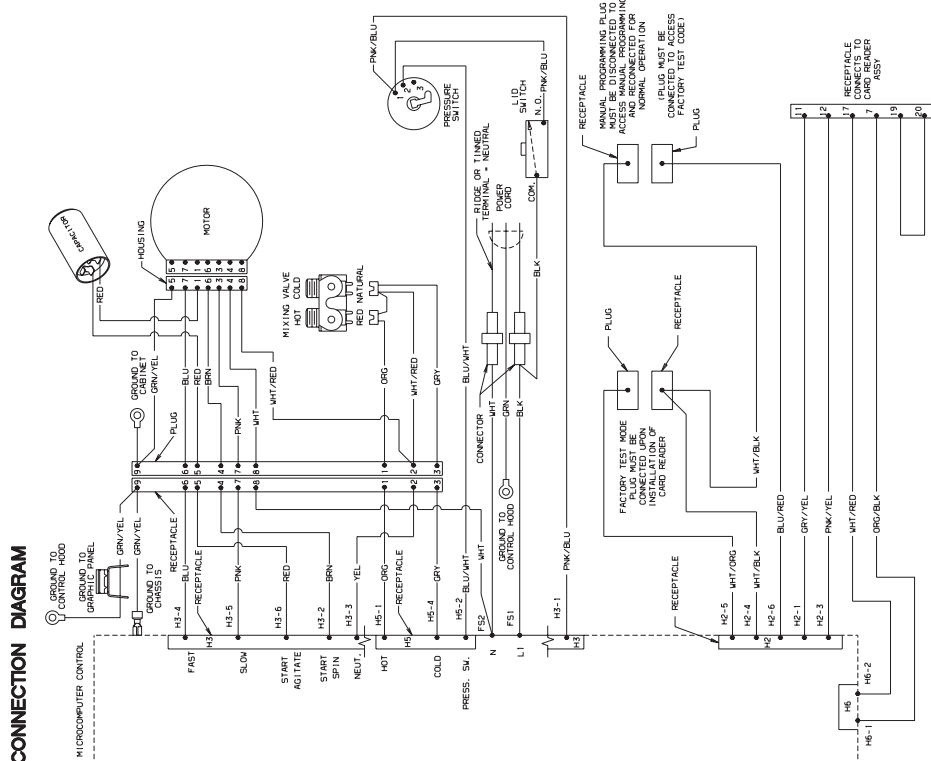
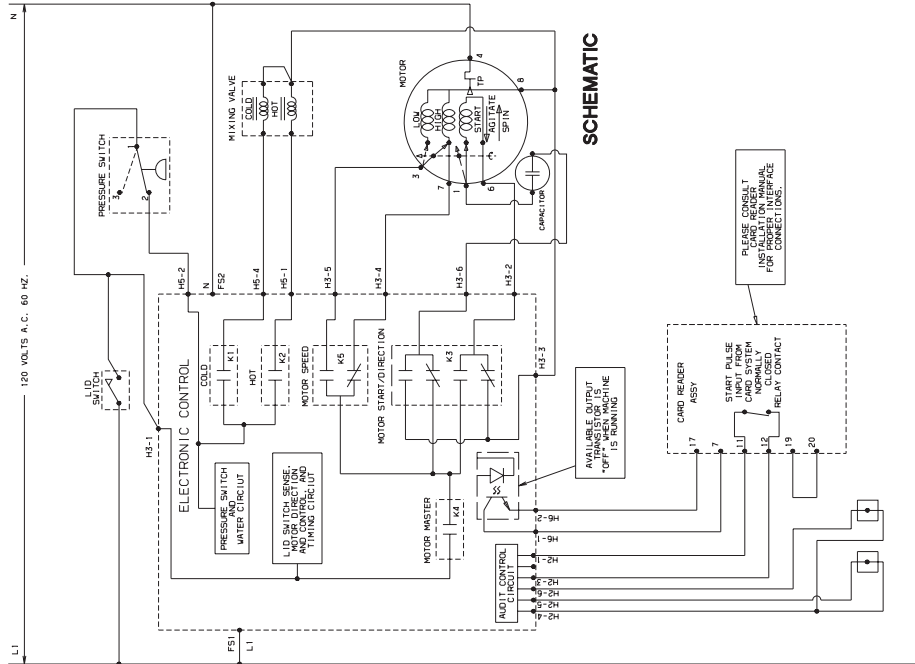

MODEL SWT620*A

THIS MACHINE MANUFACTURED BY ALLIANCE LAUNDRY SYSTEMS, INC. PATENTING PATENTS OF THE UNITED STATES NO. 3,253,874; 3,838,795; 3,845,642; 3,845,643; 3,845,644; 3,845,645; 3,845,646; 3,845,647; 3,845,648; 3,845,649; 3,845,650; 3,845,651; 3,845,652; 3,845,653; 3,845,654; 3,845,655; 3,845,656; 3,845,657; 3,845,658; 3,845,659; 3,845,660; 3,845,661; 3,845,662; 3,845,663; 3,845,664; 3,845,665; 3,845,666; 3,845,667; 3,845,668; 3,845,669; 3,845,670; 3,845,671; 3,845,672; 3,845,673; 3,845,674; 3,845,675; 3,845,676; 3,845,677; 3,845,678; 3,845,679; 3,845,680; 3,845,681; 3,845,682; 3,845,683; 3,845,684; 3,845,685; 3,845,686; 3,845,687; 3,845,688; 3,845,689; 3,845,690; 3,845,691; 3,845,692; 3,845,693; 3,845,694; 3,845,695; 3,845,696; 3,845,697; 3,845,698; 3,845,699; 3,845,700; 3,845,701; 3,845,702; 3,845,703; 3,845,704; 3,845,705; 3,845,706; 3,845,707; 3,845,708; 3,845,709; 3,845,710; 3,845,711; 3,845,712; 3,845,713; 3,845,714; 3,845,715; 3,845,716; 3,845,717; 3,845,718; 3,845,719; 3,845,720; 3,845,721; 3,845,722; 3,845,723; 3,845,724; 3,845,725; 3,845,726; 3,845,727; 3,845,728; 3,845,729; 3,845,730; 3,845,731; 3,845,732; 3,845,733; 3,845,734; 3,845,735; 3,845,736; 3,845,737; 3,845,738; 3,845,739; 3,845,740; 3,845,741; 3,845,742; 3,845,743; 3,845,744; 3,845,745; 3,845,746; 3,845,747; 3,845,748; 3,845,749; 3,845,750; 3,845,751; 3,845,752; 3,845,753; 3,845,754; 3,845,755; 3,845,756; 3,845,757; 3,845,758; 3,845,759; 3,845,760; 3,845,761; 3,845,762; 3,845,763; 3,845,764; 3,845,765; 3,845,766; 3,845,767; 3,845,768; 3,845,769; 3,845,770; 3,845,771; 3,845,772; 3,845,773; 3,845,774; 3,845,775; 3,845,776; 3,845,777; 3,845,778; 3,845,779; 3,845,780; 3,845,781; 3,845,782; 3,845,783; 3,845,784; 3,845,785; 3,845,786; 3,845,787; 3,845,788; 3,845,789; 3,845,790; 3,845,791; 3,845,792; 3,845,793; 3,845,794; 3,845,795; 3,845,796; 3,845,797; 3,845,798; 3,845,799; 3,845,800; 3,845,801; 3,845,802; 3,845,803; 3,845,804; 3,845,805; 3,845,806; 3,845,807; 3,845,808; 3,845,809; 3,845,810; 3,845,811; 3,845,812; 3,845,813; 3,845,814; 3,845,815; 3,845,816; 3,845,817; 3,845,818; 3,845,819; 3,845,820; 3,845,821; 3,845,822; 3,845,823; 3,845,824; 3,845,825; 3,845,826; 3,845,827; 3,845,828; 3,845,829; 3,845,830; 3,845,831; 3,845,832; 3,845,833; 3,845,834; 3,845,835; 3,845,836; 3,845,837; 3,845,838; 3,845,839; 3,845,840; 3,845,841; 3,845,842; 3,845,843; 3,845,844; 3,845,845; 3,845,846; 3,845,847; 3,845,848; 3,845,849; 3,845,850; 3,845,851; 3,845,852; 3,845,853; 3,845,854; 3,845,855; 3,845,856; 3,845,857; 3,845,858; 3,845,859; 3,845,860; 3,845,861; 3,845,862; 3,845,863; 3,845,864; 3,845,865; 3,845,866; 3,845,867; 3,845,868; 3,845,869; 3,845,870; 3,845,871; 3,845,872; 3,845,873; 3,845,874; 3,845,875; 3,845,876; 3,845,877; 3,845,878; 3,845,879; 3,845,880; 3,845,881; 3,845,882; 3,845,883; 3,845,884; 3,845,885; 3,845,886; 3,845,887; 3,845,888; 3,845,889; 3,845,890; 3,845,891; 3,845,892; 3,845,893; 3,845,894; 3,845,895; 3,845,896; 3,845,897; 3,845,898; 3,845,899; 3,845,900; 3,845,901; 3,845,902; 3,845,903; 3,845,904; 3,845,905; 3,845,906; 3,845,907; 3,845,908; 3,845,909; 3,845,910; 3,845,911; 3,845,912; 3,845,913; 3,845,914; 3,845,915; 3,845,916; 3,845,917; 3,845,918; 3,845,919; 3,845,920; 3,845,921; 3,845,922; 3,845,923; 3,845,924; 3,845,925; 3,845,926; 3,845,927; 3,845,928; 3,845,929; 3,845,930; 3,845,931; 3,845,932; 3,845,933; 3,845,934; 3,845,935; 3,845,936; 3,845,937; 3,845,938; 3,845,939; 3,845,940; 3,845,941; 3,845,942; 3,845,943; 3,845,944; 3,845,945; 3,845,946; 3,845,947; 3,845,948; 3,845,949; 3,845,950; 3,845,951; 3,845,952; 3,845,953; 3,845,954; 3,845,955; 3,845,956; 3,845,957; 3,845,958; 3,845,959; 3,845,960; 3,845,961; 3,845,962; 3,845,963; 3,845,964; 3,845,965; 3,845,966; 3,845,967; 3,845,968; 3,845,969; 3,845,970; 3,845,971; 3,845,972; 3,845,973; 3,845,974; 3,845,975; 3,845,976; 3,845,977; 3,845,978; 3,845,979; 3,845,980; 3,845,981; 3,845,982; 3,845,983; 3,845,984; 3,845,985; 3,845,986; 3,845,987; 3,845,988; 3,845,989; 3,845,990; 3,845,991; 3,845,992; 3,845,993; 3,845,994; 3,845,995; 3,845,996; 3,845,997; 3,845,998; 3,845,999; 3,846,000.

WARNING
 Do not operate this machine if you are not properly trained. Improper use may result in bodily injury and/or property damage.

NOTE
 POWER SUPPLY WIRING MUST HAVE CORRECT POLARITY AND GROUNDING FOR THE UNIT TO OPERATE CORRECTLY.



WARNING

Failure to install, maintain, and/or operate this machine according to the manufacturer's instructions may result in conditions which can produce bodily injury and/or property damage.

W030

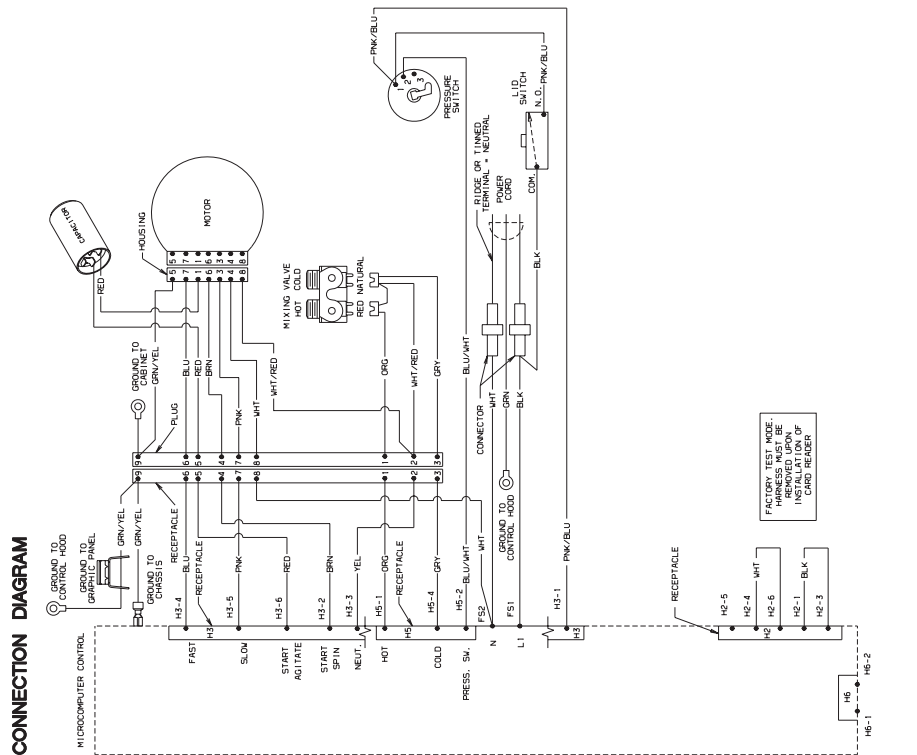
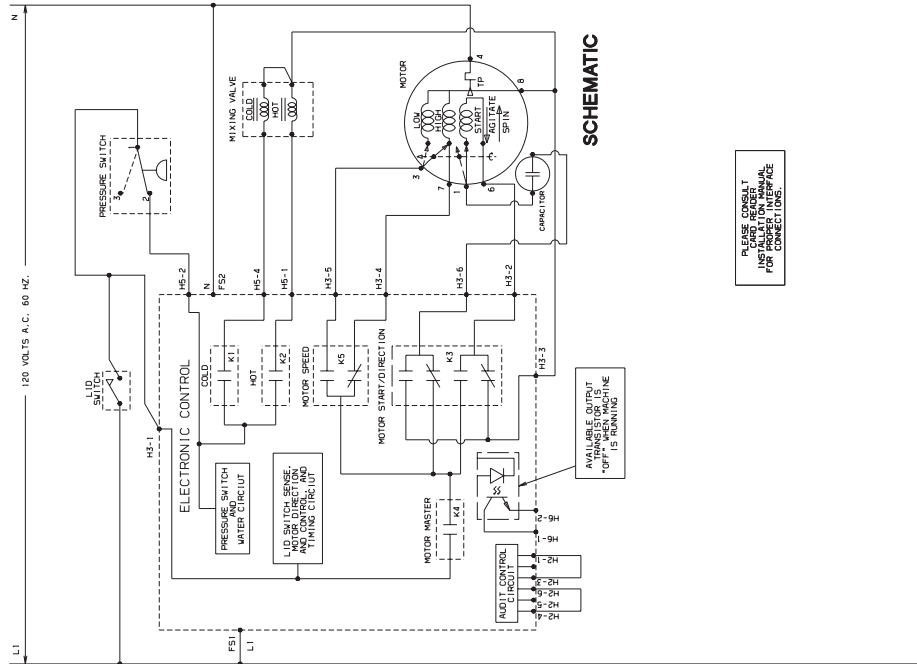

MODELS HWT620*C, SWT620*C, SWT621*C, SWT620*D AND SWT621*D

THIS MACHINE MANUFACTURED BY ALLIANCE LAUNDRY SYSTEMS, INC. OF THE FOLLOWING STATES NO. 3, 253, 874; CANADA PATENT NO. 2, 855, 642; PATENT NO. 2, 855, 642; CANADIAN NO. 1, 000, 865; OTHER PATENTS PENDING.

WARNING
FAILURE TO PROPERLY INSTALL, MAINTAIN, AND/OR OPERATE THIS MACHINE IN ACCORDANCE WITH THE INSTRUCTIONS MAY RESULT IN BODILY INJURY AND/OR PROPERTY DAMAGE.

NOTE
POWER SUPPLY WIRING MUST HAVE CORRECT POLARITY AND GROUNDING FOR THE UNIT TO OPERATE CORRECTLY.



WARNING

Failure to install, maintain, and/or operate this machine according to the manufacturer's instructions may result in conditions which can produce bodily injury and/or property damage.

W030

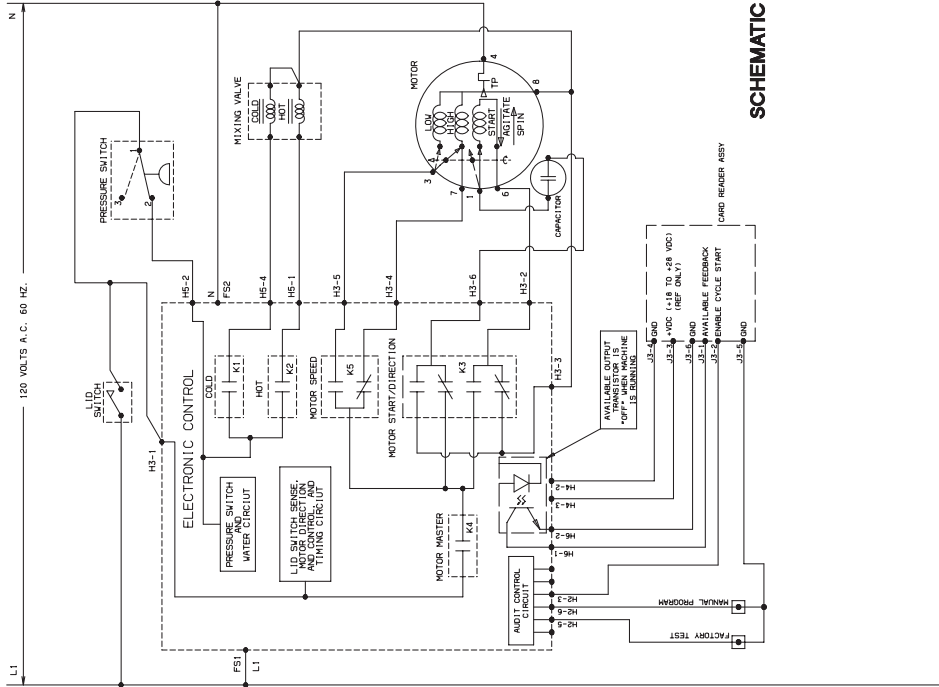

SCHEMATIC

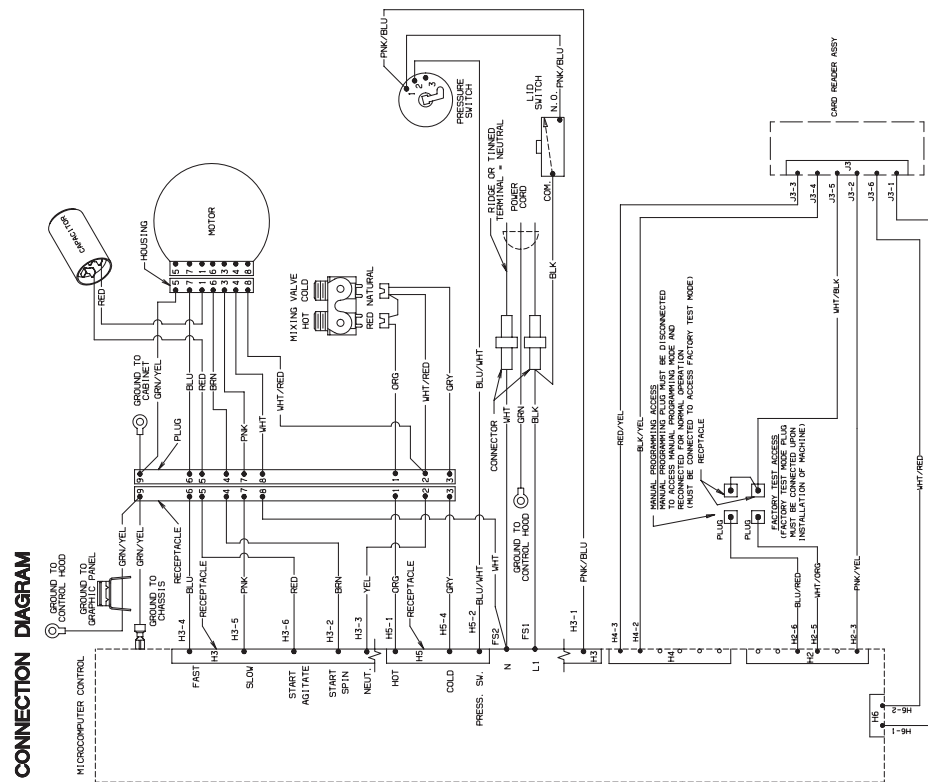

CONNECTION DIAGRAM

MODELS SWT720*A AND SWT721*A

THIS MACHINE MANUFACTURED UNDER ONE OR MORE OF THE FOLLOWING PATENTS: 3,253,874; 3,438,251; 3,845,442; 3,845,443; 3,845,444; 3,845,445; 3,845,446; 3,845,447; 3,845,448; 3,845,449; 3,845,450; 3,845,451; 3,845,452; 3,845,453; 3,845,454; 3,845,455; 3,845,456; 3,845,457; 3,845,458; 3,845,459; 3,845,460; 3,845,461; 3,845,462; 3,845,463; 3,845,464; 3,845,465; 3,845,466; 3,845,467; 3,845,468; 3,845,469; 3,845,470; 3,845,471; 3,845,472; 3,845,473; 3,845,474; 3,845,475; 3,845,476; 3,845,477; 3,845,478; 3,845,479; 3,845,480; 3,845,481; 3,845,482; 3,845,483; 3,845,484; 3,845,485; 3,845,486; 3,845,487; 3,845,488; 3,845,489; 3,845,490; 3,845,491; 3,845,492; 3,845,493; 3,845,494; 3,845,495; 3,845,496; 3,845,497; 3,845,498; 3,845,499; 3,845,500; 3,845,501; 3,845,502; 3,845,503; 3,845,504; 3,845,505; 3,845,506; 3,845,507; 3,845,508; 3,845,509; 3,845,510; 3,845,511; 3,845,512; 3,845,513; 3,845,514; 3,845,515; 3,845,516; 3,845,517; 3,845,518; 3,845,519; 3,845,520; 3,845,521; 3,845,522; 3,845,523; 3,845,524; 3,845,525; 3,845,526; 3,845,527; 3,845,528; 3,845,529; 3,845,530; 3,845,531; 3,845,532; 3,845,533; 3,845,534; 3,845,535; 3,845,536; 3,845,537; 3,845,538; 3,845,539; 3,845,540; 3,845,541; 3,845,542; 3,845,543; 3,845,544; 3,845,545; 3,845,546; 3,845,547; 3,845,548; 3,845,549; 3,845,550; 3,845,551; 3,845,552; 3,845,553; 3,845,554; 3,845,555; 3,845,556; 3,845,557; 3,845,558; 3,845,559; 3,845,560; 3,845,561; 3,845,562; 3,845,563; 3,845,564; 3,845,565; 3,845,566; 3,845,567; 3,845,568; 3,845,569; 3,845,570; 3,845,571; 3,845,572; 3,845,573; 3,845,574; 3,845,575; 3,845,576; 3,845,577; 3,845,578; 3,845,579; 3,845,580; 3,845,581; 3,845,582; 3,845,583; 3,845,584; 3,845,585; 3,845,586; 3,845,587; 3,845,588; 3,845,589; 3,845,590; 3,845,591; 3,845,592; 3,845,593; 3,845,594; 3,845,595; 3,845,596; 3,845,597; 3,845,598; 3,845,599; 3,845,600; 3,845,601; 3,845,602; 3,845,603; 3,845,604; 3,845,605; 3,845,606; 3,845,607; 3,845,608; 3,845,609; 3,845,610; 3,845,611; 3,845,612; 3,845,613; 3,845,614; 3,845,615; 3,845,616; 3,845,617; 3,845,618; 3,845,619; 3,845,620; 3,845,621; 3,845,622; 3,845,623; 3,845,624; 3,845,625; 3,845,626; 3,845,627; 3,845,628; 3,845,629; 3,845,630; 3,845,631; 3,845,632; 3,845,633; 3,845,634; 3,845,635; 3,845,636; 3,845,637; 3,845,638; 3,845,639; 3,845,640; 3,845,641; 3,845,642; 3,845,643; 3,845,644; 3,845,645; 3,845,646; 3,845,647; 3,845,648; 3,845,649; 3,845,650; 3,845,651; 3,845,652; 3,845,653; 3,845,654; 3,845,655; 3,845,656; 3,845,657; 3,845,658; 3,845,659; 3,845,660; 3,845,661; 3,845,662; 3,845,663; 3,845,664; 3,845,665; 3,845,666; 3,845,667; 3,845,668; 3,845,669; 3,845,670; 3,845,671; 3,845,672; 3,845,673; 3,845,674; 3,845,675; 3,845,676; 3,845,677; 3,845,678; 3,845,679; 3,845,680; 3,845,681; 3,845,682; 3,845,683; 3,845,684; 3,845,685; 3,845,686; 3,845,687; 3,845,688; 3,845,689; 3,845,690; 3,845,691; 3,845,692; 3,845,693; 3,845,694; 3,845,695; 3,845,696; 3,845,697; 3,845,698; 3,845,699; 3,845,700; 3,845,701; 3,845,702; 3,845,703; 3,845,704; 3,845,705; 3,845,706; 3,845,707; 3,845,708; 3,845,709; 3,845,710; 3,845,711; 3,845,712; 3,845,713; 3,845,714; 3,845,715; 3,845,716; 3,845,717; 3,845,718; 3,845,719; 3,845,720; 3,845,721; 3,845,722; 3,845,723; 3,845,724; 3,845,725; 3,845,726; 3,845,727; 3,845,728; 3,845,729; 3,845,730; 3,845,731; 3,845,732; 3,845,733; 3,845,734; 3,845,735; 3,845,736; 3,845,737; 3,845,738; 3,845,739; 3,845,740; 3,845,741; 3,845,742; 3,845,743; 3,845,744; 3,845,745; 3,845,746; 3,845,747; 3,845,748; 3,845,749; 3,845,750; 3,845,751; 3,845,752; 3,845,753; 3,845,754; 3,845,755; 3,845,756; 3,845,757; 3,845,758; 3,845,759; 3,845,760; 3,845,761; 3,845,762; 3,845,763; 3,845,764; 3,845,765; 3,845,766; 3,845,767; 3,845,768; 3,845,769; 3,845,770; 3,845,771; 3,845,772; 3,845,773; 3,845,774; 3,845,775; 3,845,776; 3,845,777; 3,845,778; 3,845,779; 3,845,780; 3,845,781; 3,845,782; 3,845,783; 3,845,784; 3,845,785; 3,845,786; 3,845,787; 3,845,788; 3,845,789; 3,845,790; 3,845,791; 3,845,792; 3,845,793; 3,845,794; 3,845,795; 3,845,796; 3,845,797; 3,845,798; 3,845,799; 3,845,800; 3,845,801; 3,845,802; 3,845,803; 3,845,804; 3,845,805; 3,845,806; 3,845,807; 3,845,808; 3,845,809; 3,845,810; 3,845,811; 3,845,812; 3,845,813; 3,845,814; 3,845,815; 3,845,816; 3,845,817; 3,845,818; 3,845,819; 3,845,820; 3,845,821; 3,845,822; 3,845,823; 3,845,824; 3,845,825; 3,845,826; 3,845,827; 3,845,828; 3,845,829; 3,845,830; 3,845,831; 3,845,832; 3,845,833; 3,845,834; 3,845,835; 3,845,836; 3,845,837; 3,845,838; 3,845,839; 3,845,840; 3,845,841; 3,845,842; 3,845,843; 3,845,844; 3,845,845; 3,845,846; 3,845,847; 3,845,848; 3,845,849; 3,845,850; 3,845,851; 3,845,852; 3,845,853; 3,845,854; 3,845,855; 3,845,856; 3,845,857; 3,845,858; 3,845,859; 3,845,860; 3,845,861; 3,845,862; 3,845,863; 3,845,864; 3,845,865; 3,845,866; 3,845,867; 3,845,868; 3,845,869; 3,845,870; 3,845,871; 3,845,872; 3,845,873; 3,845,874; 3,845,875; 3,845,876; 3,845,877; 3,845,878; 3,845,879; 3,845,880; 3,845,881; 3,845,882; 3,845,883; 3,845,884; 3,845,885; 3,845,886; 3,845,887; 3,845,888; 3,845,889; 3,845,890; 3,845,891; 3,845,892; 3,845,893; 3,845,894; 3,845,895; 3,845,896; 3,845,897; 3,845,898; 3,845,899; 3,845,900; 3,845,901; 3,845,902; 3,845,903; 3,845,904; 3,845,905; 3,845,906; 3,845,907; 3,845,908; 3,845,909; 3,845,910; 3,845,911; 3,845,912; 3,845,913; 3,845,914; 3,845,915; 3,845,916; 3,845,917; 3,845,918; 3,845,919; 3,845,920; 3,845,921; 3,845,922; 3,845,923; 3,845,924; 3,845,925; 3,845,926; 3,845,927; 3,845,928; 3,845,929; 3,845,930; 3,845,931; 3,845,932; 3,845,933; 3,845,934; 3,845,935; 3,845,936; 3,845,937; 3,845,938; 3,845,939; 3,845,940; 3,845,941; 3,845,942; 3,845,943; 3,845,944; 3,845,945; 3,845,946; 3,845,947; 3,845,948; 3,845,949; 3,845,950; 3,845,951; 3,845,952; 3,845,953; 3,845,954; 3,845,955; 3,845,956; 3,845,957; 3,845,958; 3,845,959; 3,845,960; 3,845,961; 3,845,962; 3,845,963; 3,845,964; 3,845,965; 3,845,966; 3,845,967; 3,845,968; 3,845,969; 3,845,970; 3,845,971; 3,845,972; 3,845,973; 3,845,974; 3,845,975; 3,845,976; 3,845,977; 3,845,978; 3,845,979; 3,845,980; 3,845,981; 3,845,982; 3,845,983; 3,845,984; 3,845,985; 3,845,986; 3,845,987; 3,845,988; 3,845,989; 3,845,990; 3,845,991; 3,845,992; 3,845,993; 3,845,994; 3,845,995; 3,845,996; 3,845,997; 3,845,998; 3,845,999; 3,846,000.

WARNING
Failure to install, maintain, and/or operate this machine according to the manufacturer's instructions may result in conditions which can produce bodily injury and/or property damage.

NOTE
POWER SUPPLY WIRING MUST HAVE CORRECT POLARITY AND GROUNDING FOR THE UNIT TO OPERATE CORRECTLY.



WARNING

Failure to install, maintain, and/or operate this machine according to the manufacturer's instructions may result in conditions which can produce bodily injury and/or property damage.

W030

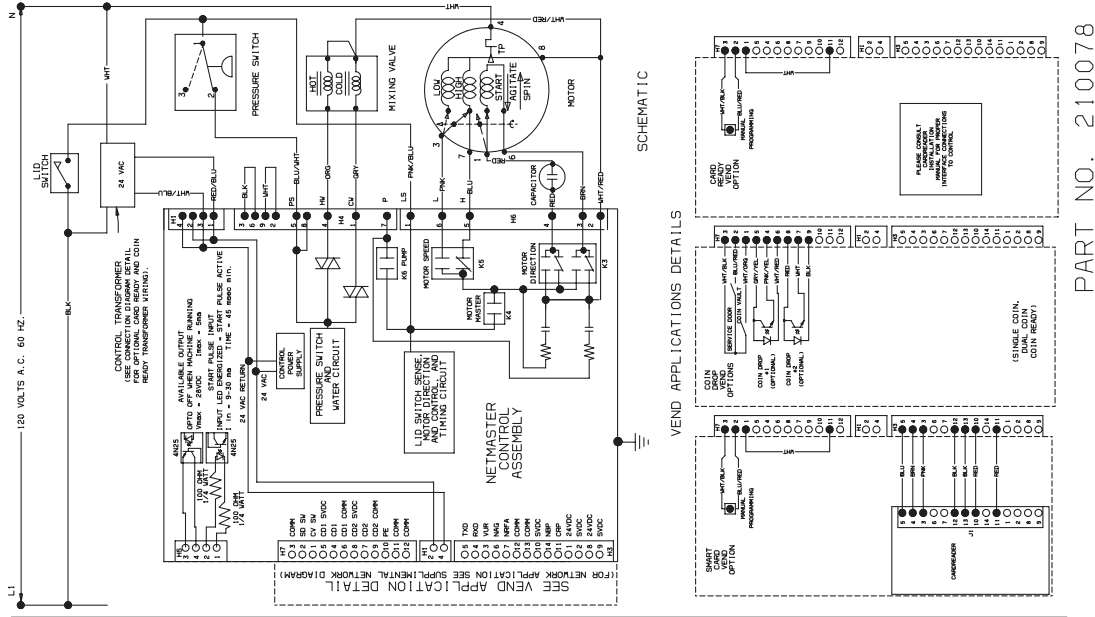

PART NO. 210078

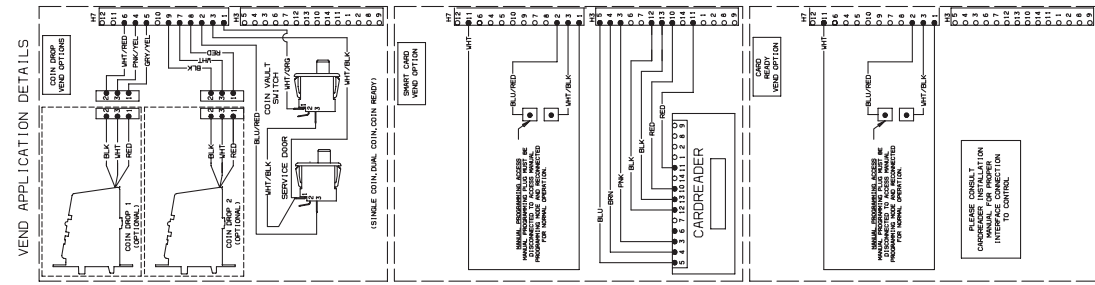
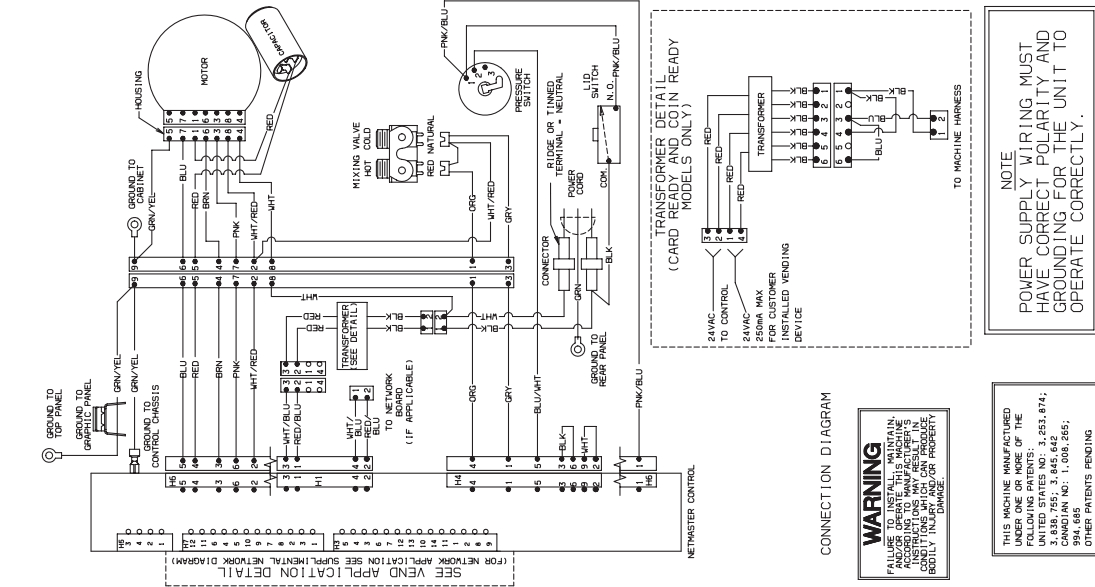

MODELS SWTA21*M, SWTB20*M, SWTB21*J, SWTB21*M, SWTC20*M, SWTC21*M, SWTF20*M, SWTF21*M, SWTH21*J, SWTH21*M AND SWTJ21*M