

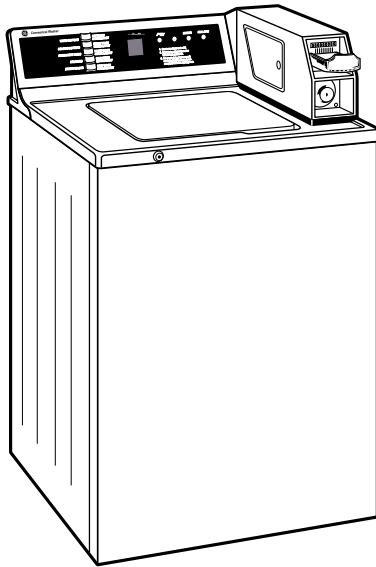

TECHNICAL SERVICE GUIDE

GE Coin-Operated Washers



MODEL SERIES

WCCB1030WYC WCCB1030YAC
WCCD1030YWC WCCD1030YAC
WLCD1030YWC WLCD1030YAC

WCCD2050YWC WCCD2050YAC
WLCD2050YWC WLCD2050YAC

Table of Contents

Rating Plate/Mini Manual	2
Countback Backsplash	3
Specifications/Features	4
Dimensions/Water Usage	5
Installation Instructions	6-9
Filter/Agitator	10
Control Panel Service	11
Timer	12
Cabinet/Front Panel/Cover-Lid	13
Economy Water Usage	14
Suspension	15
Spin Basket Removal	16
Tub/Motor Assembly Service	17
Remote Pump, Motor/Clutch	18
Clutch Removal/Belt Tension	19
Transmission Service	20-21
Schematic	22-23
Exploded Views/Parts	24-34

Rating Plate and Mini-Manual Location

The rating plate containing model and serial number is located on the rear of the control panel in the center. If you lean over the washer you can see the rating plate without moving the unit.

Rating Plate
at rear of
backsplash

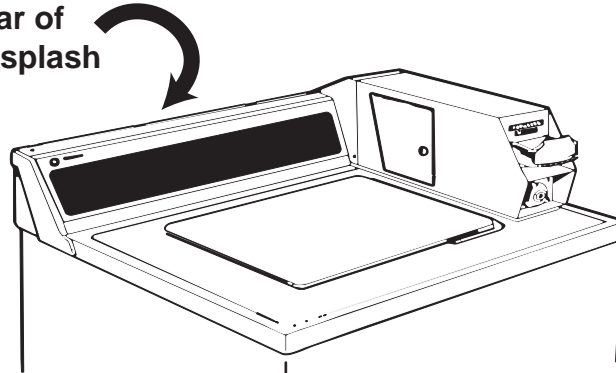

The full size electronic washer incorporates optimum washability, capacity, quiet operation, and ease of service. The washer is 100 percent front serviceable, with 40% fewer parts. It features an Auto Balance suspension system, that allows greater out of balance capacity.

Drive system has a rotating transmission with metal gears and a disc brake, and it comes as a single replaceable component. The brake is activated when the end of cycle occurs and also, when the lid is lifted.

All washers are manufactured and supplied with provisions for proper grounding. The installation instructions advise on proper grounding. Safety devices should never be removed unless for servicing, and must always be replaced prior to placing the washer back in active service.

The mini manual is located in the backsplash, and contains service information

Suggested Tool List:

- #2 Philips, small slot blade screwdriver
- 1/4", 3/8", 7/16", nutdrivers
- 3/8", 3/4" open-end wrench
- 1/2" socket and ratchet
- Pliers
- Special agitator puller WX5X1326
- Special hub nut tool WX5X1325
- Hammer
- T20H Torx head security screwdriver
- Locking pliers
- Wire tie to reattach overflow tube

Mini Manual Location

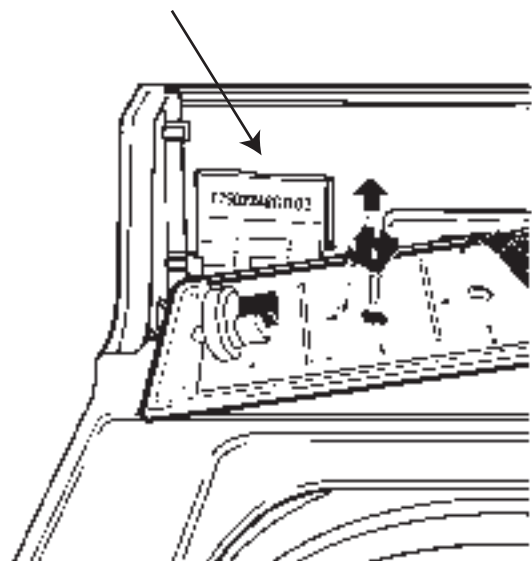

Countdown display models (not all shown), WCCD and WLCD models only.

The countdown display shows the remaining time in the cycle on the face of the control panel. The display board should be replaced if it fails, it is not repairable. Instructions for removing and replacing display board is located on page 12. The display board is configured properly at the factory for the correct cycle timer installed in the washer. If you wish to change the cycle timer, or add a debit card interface to the washer you will need to change the configuration setting of the Countdown PC Board as shown below. Note Switch Numbers on top row of chart, with function to the left, settings in middle.

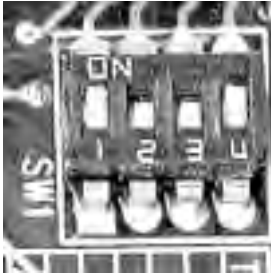

BOARD VIEW (INSIDE BACKSPLASH)



CORRECT SWITCH SETTINGS FROM FACTORY

	Switch Numbers			
	1	2	3	4
Short Wash:	1	0	1	0
Short Wash: with Debit Card:	1	0	1	0
Long Wash:	1	1	0	0
Long Wash: with Debit Card:	0	0	0	0

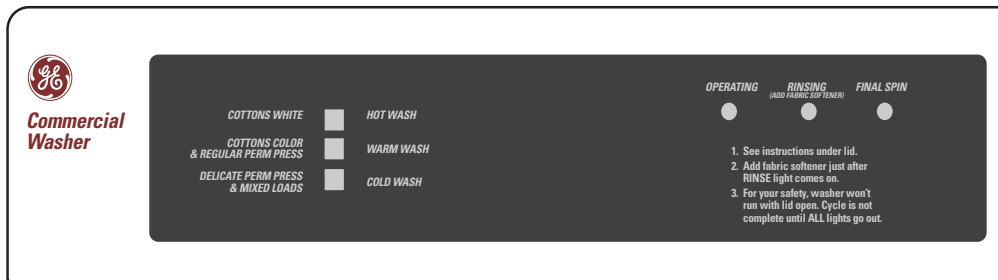

WCCB1030



WCCD1030



WCCD2050

Features - Specifications

Capacity	2.7 Cu. Ft.
Spin Speeds	630 RPM Fast 420 RPM Slow
Agitation <ul style="list-style-type: none"> • Stroke rate -fast/slow • Arc of stroke 	154/108 Strokes per minute 108 Degrees
Agitator	Dual Action
Water Levels	3 Adjustable water levels-Economy option available by adjusting water pressure switch.
Suspension Finish	Auto Balance Suspension System Armor Guard Protection
Cabinet	Galvanized Steel Cabinet and Base
Wash Cycle Service	18.5 Minute wash Cycle 100% Front Serviceable
Lid Switch	Tamper Resistant
Electronic Cycle Countback	Yes
Wash Cycles/Speeds	WCCD1030Y *WLCD1030Y & WLCD2050Y WCCD2050Y are long cycle models
Basket and Tub	Permatuf II Basket/Polypropylene tub
Motor	Form W - Two speed motor clutch as a single unit capacitor start. Form T - Single Speed, centrifugal switch.
Controls	Pushbutton
Voltage	115V 60 Hz. Protect with 15 to 20 amp Individual branch circuit
Warranty	3 Year Parts Warranty 5 Year Part Warranty on Outer Tub, Inner Basket, and Cabinet Rust-Through.

Low Water Consumption			
Water Temperature			
Cycle Selection	Hot	Cold	Total
Standard Hot Wash	15.5	16.5	32 gallons
Standard Warm Wash	6.1	25.9	32 gallons
Economy Hot Wash	14.4	14.6	29 gallons
Economy Warm Wash	5.6	23.4	29 gallons

Water usage values are determined using a standard AHAM 14 lb. load--water usage may be slightly higher or lower.

- **GE exclusive features:**
Armor Guard Protection
Tested rust resistant durable finish.
No rust or chips.
- **Perm-Tuf II Basket**
No Rust No chipping
- **Auto Balance Suspension System**
Virtually eliminates off-balanced loads.
Featuring the innovative floating suspension system and balance ring
- **3 Adjustable water levels**
- **18.5 Minute Wash Cycle**
18.5 minutes plus fill time. Reduction of 11 minutes versus prior model.
- **100% Front Servicable**
All operation parts can be serviced without moving the unit.
- **Tamper Resistant Lid switch**
Minimizes vandalized lid switches
- **Plus Debit Card Capability**
Accessory kit designed exclusively for GE

Dimensions/Water Consumption

Low Water Consumption			
Water Temperature			
Cycle Selection	Hot	Cold	Total
Standard Hot Wash	15.5	16.5	32 gallons
Standard Warm Wash	6.1	25.9	32 gallons
Economy Hot Wash	14.4	14.6	29 gallons
Economy Warm Wash	5.6	23.4	29 gallons

Water usage values are determined using a standard AHAM 14 lb. load--water usage may be slightly higher or lower.

Energy Saving

All wash cycles include energy-saving cold water rinse. Connector in backslash can be joined for warm rinse. Total cycle time --- 29 minutes plus fill time. Actual wash time is 11 minutes with final spin speed of approximately 630 RPM. The washer will automatically turn itself off upon completion of the cycle.

Electrical Requirement: 115 Volts, 60 Hertz, an individual properly grounded 15- or 20 amp branch circuit is required.

Note: Coin slide or coin drop, coin vault, and locks for cover and meter case access door are not provided with washer.

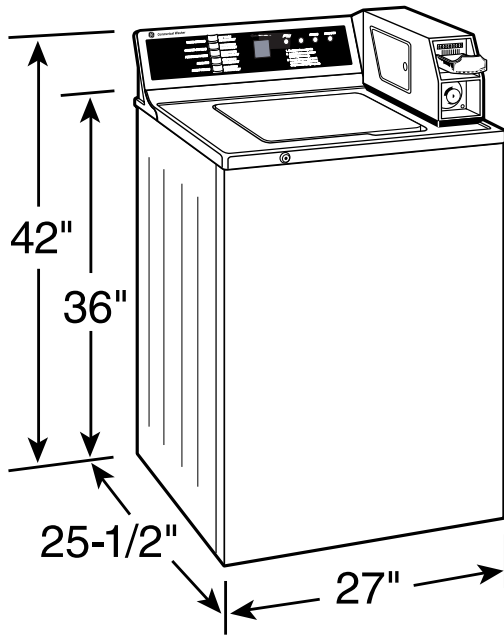

NOTE:

Coin slide or coin drop, coin vault, and locks for cover and meter case access door are not provided with washer.

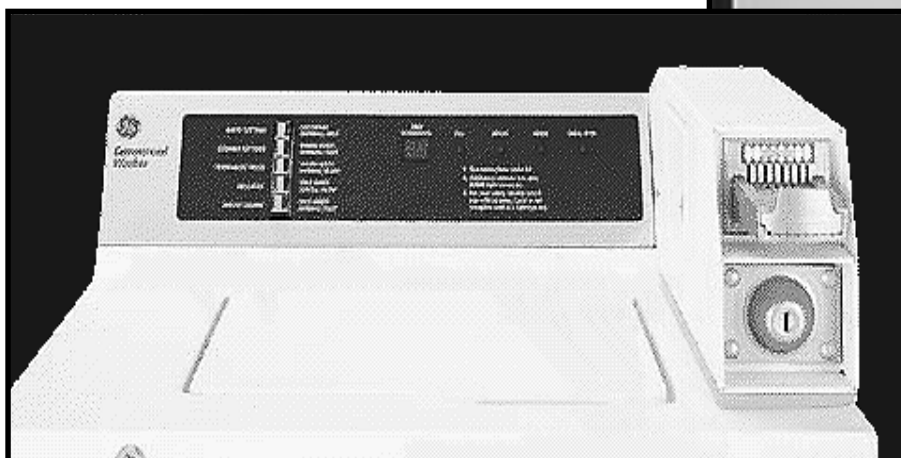

Installation Instructions

Installation instructions for your new commercial clothes washer

28

Before you begin – Read these instructions completely and carefully
IMPORTANT – OBSERVE ALL GOVERNING CODES AND ORDINANCES.
 Note – This appliance must be properly grounded.

INSTALLATION REQUIREMENTS

LOCATION

Washer must be installed on firm flooring to minimize vibration during spin cycles. Concrete flooring is best but wood base is sufficient providing floor support meets FEA standards. Washer should not be installed on rug or exposed to the weather.

PLUMBING

• **WATER PRESSURE** – Must be 10 psi minimum to 150 psi maximum dynamic pressure (measured at faucet).

• **WATER TEMPERATURE** - Household water heater should be set to deliver water at 120° to 130°F (50° to 60°C) IN THE WASHER when HOT wash is selected.

• **SHUT-OFF VALVES** – Both hot and cold shut-off valves (faucets) should be supplied.

• **DRAIN** – Water can be drained into a standpipe or vent tub. The discharge height **MUST NOT BE LESS THAN 30 INCHES** nor more than 8 feet above the base of the washer. The standpipe must be 1-1/2 inches minimum inside diameter and must be open to the atmosphere.

ELECTRICAL

This appliance must be supplied with 115V, 60 Hz, and connected to an individual, properly grounded branch circuit, protected by a 15 or 20 amp circuit breaker or time-delay fuse.

TOOLS YOU WILL NEED

Socket set
 Slip joint pliers

TYPICAL HOSE INSTALLATIONS

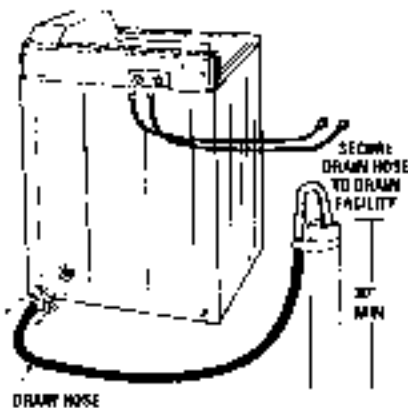

DRAIN HOSE

RECESSED PLUMBING

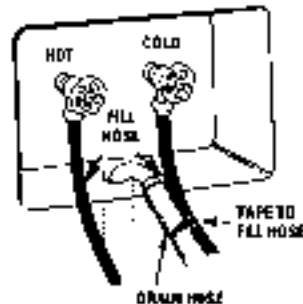

DRAIN HOSE

• Drain hoses must be securely attached to washer and drain facility with plastic tie strap or tape.

• Fill hose connections must be tight.

COUNTDOWN DISPLAY (WCCD MODELS ONLY)

The countdown display shows the remaining time in the cycle. The display board is configured properly at the factory for the correct cycle times installed in the washer. If you wish to change the cycle timer, or add a delay card interface to the washer, you need to change the configuration setting of the countdown display board as follows:

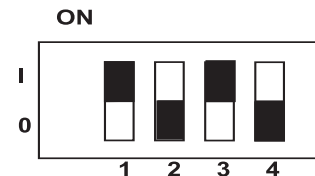

	Switch Numbers			
	1	2	3	4
Short Wash:	1	0	1	0
Short Wash: with Debit Card:	1	0	1	0
Long Wash:	1	1	0	0
Long Wash: with Debit Card:	0	0	0	0

Specifications subject to change without notice.

STEP 1

PREPARE WASHER FOR INSTALLATION

1. Remove cardboard inner pack and installation accessories from under fill. Drain hose with washer basket.
2. Grasp retainer end on lower right side (has a tag on strap), and pull rest straight out and downward.



3. Move washer to installation location for remaining hose and electrical preparation.

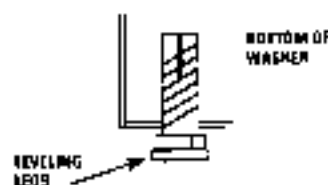

STEP 2

DRAIN HOSE ATTACHMENT

1. Remove all installation items from the washer basket.
2. **IMPORTANT:** Remove red plug from drain hose port.
(NOTE: Some water may be present, this is normal.)
3. Locate short white plastic drain hose adapter. Place hose clamp over black drain hose end. Insert drain hose adapter into bent end of drain hose, and position clamp to secure hose adapter to drain hose. Push plastic drain hose clamp over hose adapter into grooved slot.

(NOTE: Requires some force to install, and has a positive click when forced into slot.)

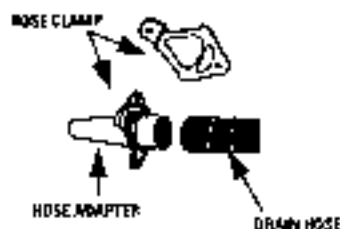

4. Push white plastic conical end of drain hose adapter into washer drain hose port. Insert two black screws (found in installation pack), and drive to insert drain hose to washer.

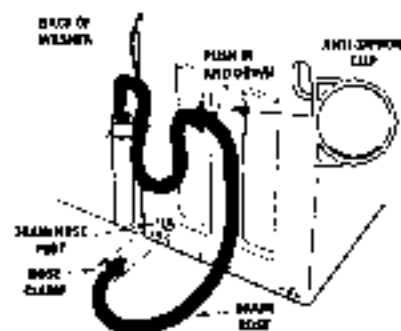

NOTE: If drain hose facility doesn't meet the 30" minimum star pipe height requirement, thread drain hose through supplied anti siphon clip and mount to cabinet back as shown.

STEP 3

FILL HOSE ATTACHMENT

Insert rubber washers into both ends of each fill hose. Attach fill hose marked HOT to right washer inlet valve. Attach fill hose marked COLD to left washer inlet valve. Couplings should be hand-tightened plus 1/2 turn with pliers.

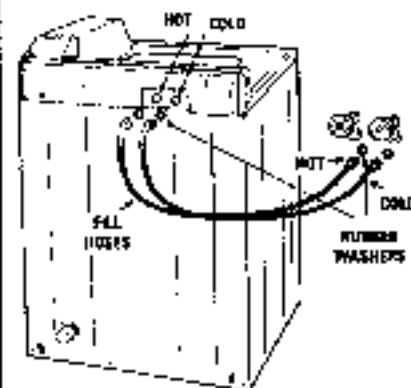

STEP 4

WASHER ELECTRICAL PREPARATION

If required, an external ground wire (not provided) which meets local codes may be added. Attach to washer (cabinet) with sheet metal screw that provided to rear of washer as illustrated. The screw required is a #8 sheet metal screw, 18 threads per inch, 1/2 inch long. It can be obtained locally at any hardware store.

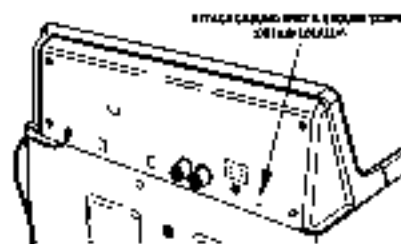

STEP 5

PREPARE TO INSTALL WASHER

1. Be sure water supply lines have been thoroughly flushed.
2. Move washer to final location.
DO NOT let feet or drain hoses drag and get under washer.
3. Adjust front leveling legs as necessary to level washer. Front leveling legs are adjustable; if adjustment is necessary, relevel. The washer must rest firmly on all four legs. To "set" rear self-leveling system, tip washer forward so that rear base is about 1" off the floor, then drop.
4. Install drain hose in drain facility and secure with plastic tie strap provided or tape as illustrated.

NOTE: Drain hose nozzle may be shortened if original length prevents full insertion into drain facility.

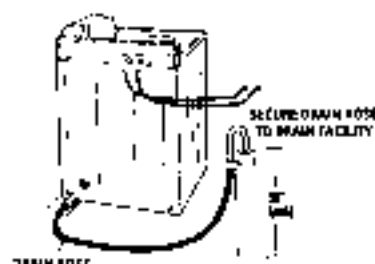

NEEDED PLUMBING

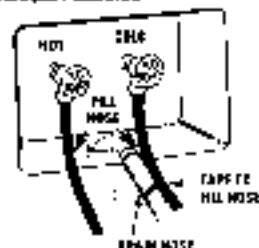

CAUTION: BE SURE DRAIN HOSE IS FIRMLY SECURED TO DRAIN FACILITY.

5. Determine which is HOT water line before attaching fill hoses to faucets. Traditionally, HOT faucet is on the left. Be sure rubber washers are in end of both washer fill hoses and runner hose from right inlet valve on washer (marked HOT); in HOT faucet and left hose to COLD faucet. Couplings should be hand-tightened plus 1/2 turn with pliers.

STEP 6

INSTALL DRAIN NOZZLE

1. Insert one end of aluminum drain nozzle into standpipe.
2. Slip on cut wire wrap back approx. 2" below top of standpipe.
3. Cut drain hose just below standpipe. Place silver hose clamp over black drain hose end.

STEP 6 (cont'd)

4. Insert drain nozzle into end of drain hose, and position clamp to secure drain nozzle to drain hose.

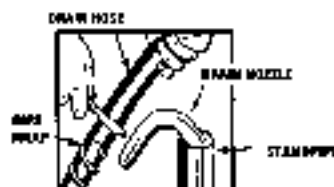

CAUTION: BE SURE DRAIN HOSE IS TAPED OR SECURED TO STANDPIPE OR OTHER DRAIN FACILITY.

NOTE: Water may be drained into a standpipe. The discharge height must not be less than 30 inches, nor more than 8 feet above base of washer. Standpipe must be 1-1/2" minimum inside diameter and must be open to atmosphere.

STEP 7

ECONOMY WATER USAGE

The pressure switch is set in the factory for the high water level and usage.

To change setting from high water level to medium or low:

1. Make sure washer is unplugged from electrical outlet.
2. Remove 4 lock screws from back of control panel and lay control panel front on cover.

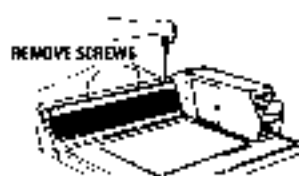

3. From the front, move white plastic cam on pressure switch to the clockwise position with your finger until it clicks over into the medium or low water position. (See illustration below.)



STEP 8

ELECTRICAL CONNECTION

CAUTION: BEFORE PLUGGING IN APPLIANCE, READ ELECTRICAL AND PLUMBING REQUIREMENTS AND CHECK LIST.

No other electrical devices should be operated on the same circuit while washer is operating.

Plug electrical power cord into a properly grounded wall outlet.

SPECIAL INSTRUCTIONS

COVER SECURITY LOCK INSTALLATION

Washer cover is designed to accept standard type lock as shown below.

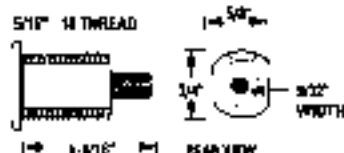

CAM LOCK AVAILABLE FROM GREENWALD - CATALOG #9-1222



To install lock:

1. Remove plastic insert in front of cover.
2. Install the lock washer on the lock shaft and locate so that the lock can be engaged in a counterclockwise direction.
3. Insert lock mechanism into cover opening and tighten until snug. (Overtightening may damage painted surfaces.)
4. Install cam and tighten until snug.

ACCESS DOOR LOCK INSTALLATION

To remove the access door retaining before installing a lock, place the door over a wood block with a 1/2" hole drilled in it and tap end of screw lightly with a hammer.

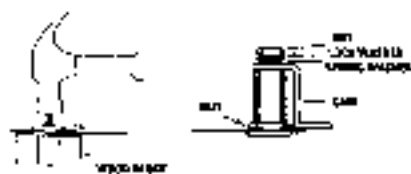

WARM RINSE OPTION

This washer is wired at the factory to provide COLD rinse only. To provide WARM rinse:

1. **WARNING:** Disconnect electrical supply.
2. Open the backslash by removing the 4 lock screws across the top.
3. Roll the front of the escutcheon towards you to open backslash.
4. Find the two single in-line plastic connector blocks in the lower right of the backslash.
5. Connect the two blocks together.



6. Close the backslash. (Be sure wires are not pinched.)
7. Reconnect power.

ELECTRICAL AND PLUMBING REQUIREMENTS

CAUTION: FOR PERSONAL SAFETY DO NOT USE AN EXTENSION CORD OR ADAPTER PLUG WITH THIS APPLIANCE.

DO NOT, UNDER ANY CIRCUMSTANCES, CUT OR REMOVE THE THIRD GROUNDING PRONG FROM THE POWER CORD.

FOLLOW NATIONAL ELECTRIC CODE (ANSI/NFPA 70) OR LOCAL CODES AND ORDINANCES.

ELECTRICAL AND PLUMBING REQUIREMENTS (cont'd)

• No other electrical device should be operated on the same circuit while washer is operating.

• This appliance must be supplied with 115V, 60 Hz and connected to an individual properly grounded branch circuit protected by a 15 or 20 amp circuit breaker or time-delay fuse.

• If the electric supply provided does not meet the above specifications, call a licensed electrician.

• Water pressure – 10 psi min., 150 psi max. (dynamic pressure measured at faucet).

• Water temperature from water heater: 120° to 130°F (50° to 66°C).



NOTE TO INSTALLER – AFTER INSTALLATION CHECK THE FOLLOWING:

• **DRAIN HOSE** – must be pulled tight and secured to drain facility to prevent lifting out of drain facility during discharge. Straddle clamp must be securely tightened to prevent leaks. MAKE SURE DRAIN HOSE IS NOT RUBBING AGAINST CONCRETE OR BLOCK WALL. RUBBING MAY WEAR HOLES IN HOSE.

• **HOSE WASHERS** – Rubber washers in both ends of fill hoses.

• **HOSE CONNECTIONS** – Hot side (right valve) connected to hot water supply, cold side (left valve) to cold water supply. All connections should be hand tightened plus 1/2 turn with pliers.

• **GROUNDING** – Must be properly grounded to conform to local codes and ordinances.

• **LEVELING** – Adjust front leveling legs as necessary (pivoted from the bottom at 1"). Check side to side and front to back. Lift forward approximately 4" lower to adjust rear self-leveling legs.

• **OPERATION** – Turn on faucets and run washer through complete cycle by hand. Check for leaks, noise, vibration, correct water temperatures and proper operation in wash and spin. While washer is in spin, raise lid and check lid switch and brake operation.

Specifications
subject to change
without notice.

Lint Removal System

1. The lint filtering system consist of the turbo pump, agitator, air bell, and self cleaning filter at bottom of spin basket. During agitate water moves throught the sides and up from the bottom throught the self cleaning filters.

During pump down, prior to spin, the turbo pump is energized, and water is drawn out the sides and down through the self cleaning filter to clean and removal lint from the bottom side of the filter area, and flush lint down the drain.

Energy Saving

All wash cycles include energy-saving cold water rinse. Connector in backsplash can be connected for warm rinse.

Total Cycle Time

18.5 minute wash cycle, plus fill time. Wash time is 11 minutes with a final spin speed of approximately 630 RPM. Washer will automatically shut off at end of cycle.

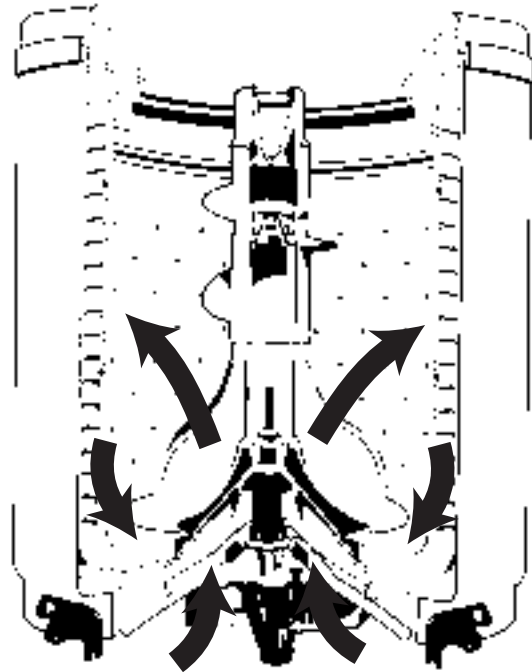

WASH

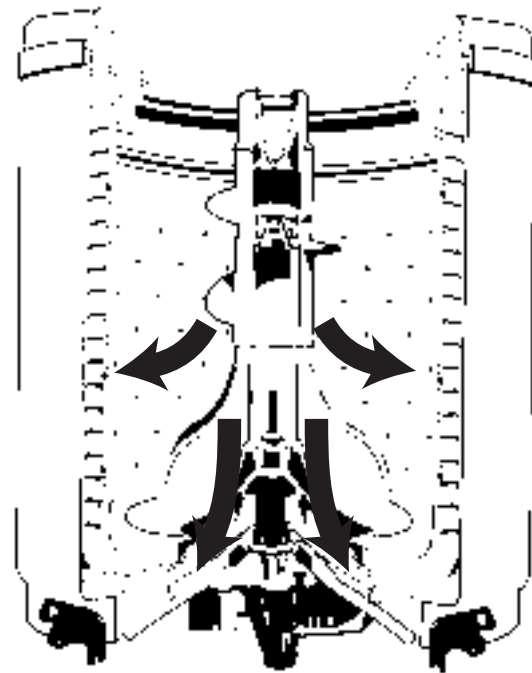

DRAIN

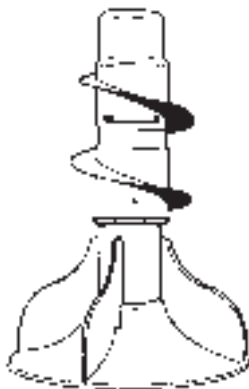

Dual Action Agitator

Control Panel

The control panel is designed with ease of service being the major consideration. The switches are tab interlock, and harness connectors are designed to only fit the correct mating connector. Control panel is galvanized, with three tabs designed to allow the switchtrim to be supported during service. Mini-Manual is located in the control panel.

1. Remove four (4) T20H Torx screws from the top of control panel as shown. (Mini-Manual can be accessed from this position as illustrated).
2. Water valve is serviceable by removing the (4) T20H Torx screws from the top of the control panel, and rotating the switchtrim forward. Two 1/4" hex screws mount the water valve to the console. The water valve can be changed from the front by first "pinching off" the inlet hoses and pulling through back of control panel to remove.

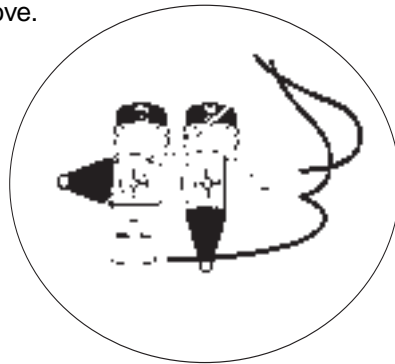
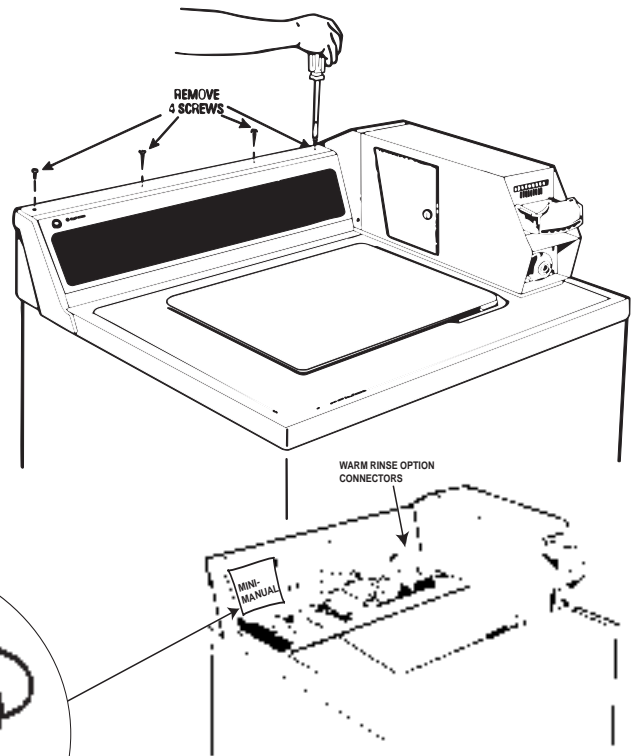

WATER VALVE CAN BE SERVICED THROUGH CONTROL PANEL

To replace Countback Display PC Board:

! WARNING! THE STEP DOWN CAPACITOR ON PC BOARD IS 120 VOLTS, AND POWER MUST BE REMOVED PRIOR TO SERVICING. THE TRACES ON THE BOARD RUNNING TO THE CAPACITOR ARE HOT!

1. Remove the four screws in the top of the control panel as shown in instruction #1 above.
2. Disconnect harness connector to pc board.
3. Pull 6 tabs as shown in illustration, one at a time, starting at connector end, while applying slight upward pressure, until all tabs are released. Remove pcboard.
4. With pcboard cover exposed, lift up on either end of cover and release the four tabs, one at a time until the cover is release and remove.
5. To reinstall, align the pc board cover, and press carefully. The tabs are beveled to make installation easy.
6. Align pc board, by inserting the counter end under the tab in plastic pcboard cover at the counter opening, and moving towards the connector end, carefully press into place, so that each tab snaps into place. Reconnect harness connector, and reinstall control panel and four screws.

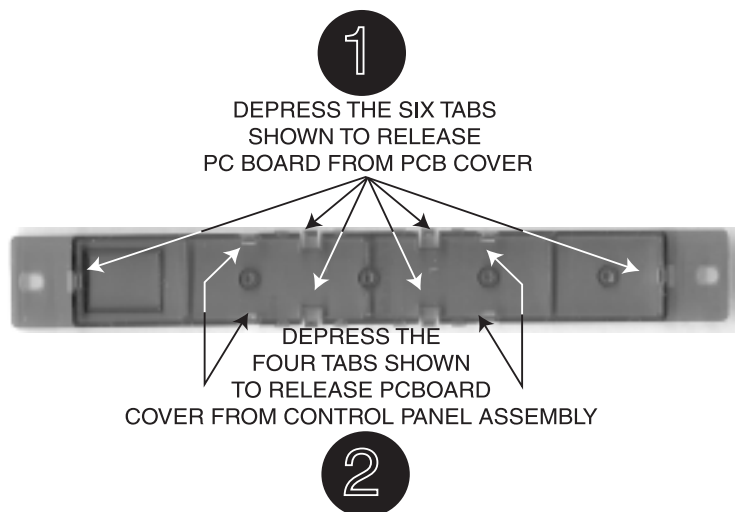

Note: Use care not to overflex the pcboard, to prevent breakage.

Timer

The timer is an Eaton double switch bank, with polarized harness connectors. This insures that the correct harness connector will only fit the mating switch bank.

Timer motor and timer are NOT interchangeable with the "S" models and earlier timers. It is stocked as one component, and repair parts are not available. The mounting bracket is stocked as a separate part and can be reused to install the replacement timer. Timer cam charts and schematics are shown in this manual.

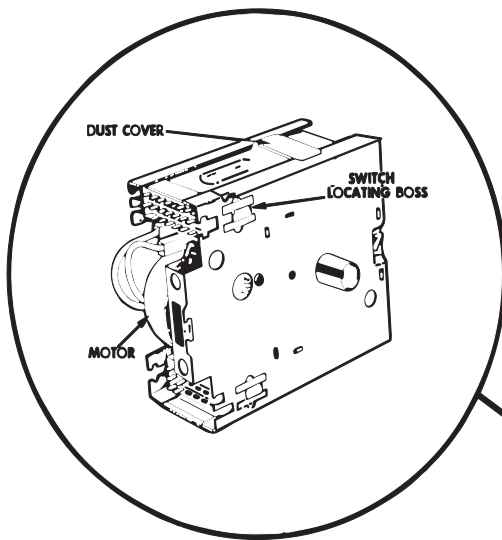

° Accessory kit with debit card capability is available and designed exclusively for GE

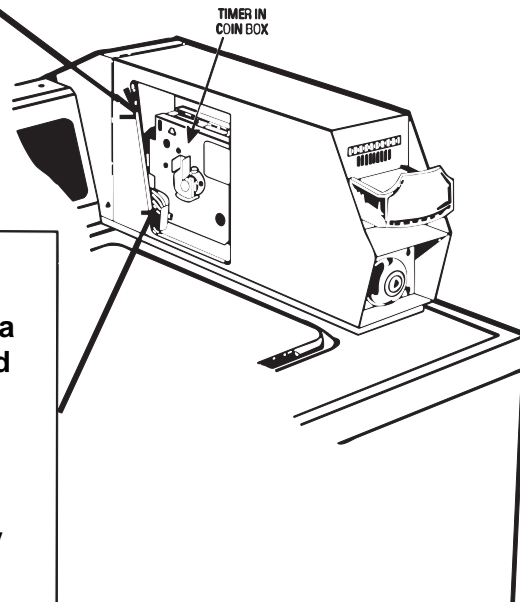

NOTE: Lid switch can be accessed by removing door and latch assembly on meter case as shown in illustration. Use a plastic pen to prevent shock hazard. Hold down lid switch activator and this will allow you to run the machine with lid up for service.

Warning! Take necessary personal safety precautions to avoid personal injury due to spin basket running with lid up.

Cabinet

Cabinet is galvanized sheet metal, with powdered paint coating and is rust resistant. It has a fully enclosed bottom, and is 3 sided with a front panel. The lid has a patented colored lid instruction that is unique to each model. Proper lid should be used to replace a lid, so that the correct instructions stay with the washer. The levelling legs are installed from the factory, and are Polypropylene with Santoprene non-skid base. Base of levelling legs have a 1" hex nut design to allow easy adjustment if necessary. Rear is self levelling, and is accomplished by lifting the rear legs 4" off the floor and lowering the washer.

LOCATE SPRING CLIPS
ON EITHER
SIDE AND RELEASE
WITH PUTTY KNIFE

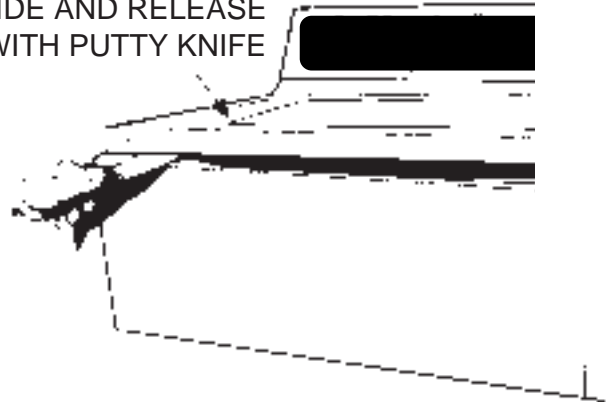

To Service Front Panel:

1. Locate the two spring clips between cover and front panel and cover.
2. Insert putty knife and push to release clips.
3. Rotate front panel forward and lift off cabinet base locating tabs.
4. To reassemble, place front panel on washer base locating tabs, rotate up into place and press top of panel at clips, until panel snaps into place.

LOCATE AND RELEASE
TWO SPRING CLIPS

To Service Cover/Lid Assembly:

1. Remove front panel.
2. Remove two 1/4" hex screws front left and right side of cabinet top support.
3. Pull cover/lid assembly towards you and up about 2".
4. Release lid switch wire connector, wires are orange/ orange white. Connector is located in right rear corner of cover, you may need to press down on wiring to allow clearance to remove connectors.
5. Remove cover/lid assembly, taking care not to allow lid to swing out and be damaged.
6. Reverse steps to reassemble.

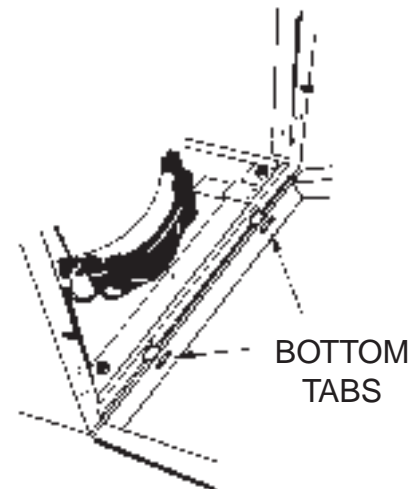

ROTATE FRONT PANEL
OUT AND LIFT OFF TABS
TO REMOVE

Water Pressure Switch

The water pressure switch is a new design and is accurate. Rotating the dial sets a cam that controls the diaphragm, the water pressure is sensed through pressure from the take off at the lower portion of the tub. Terminal connectors are marked (NC) and (NO) normally open, and common terminal on the switch.

(TECH TIP: Before disconnecting hose from water level Switch, be sure water level in machine is below bottom of wash basket. After re-connecting hose, put machine in spin for at least one minute before checking operation of switch)

1. If water level is below basket, remove control panel, and pressure switch hose.
2. Disconnect terminal connectors note (NC) Violet, (NO) Brown, (CO) Yellow- Black.
3. Check terminals for continuity.
4. If defective replace by inserting a small screwdriver under locking tab, rotating the switch counterclockwise, and lifting switch out of switch bracket to remove.
5. Reverse steps to reassemble, put machine in spin for at least one minute before checking operation of switch.

ECONOMY WATER SAVER SETTING

The pressure switch is set in the factory for the normal water level and usage.

To Change setting from normal water level to economy:

1. Make sure washer is unplugged from electrical outlet.
2. Remove 4 screws from top of control panel, and lay control panel front on cover.
- 3- Locate pressure switch in backsplash, and per illustration move white plastic cam on pressure switch to the clockwise position with your finger, until it clicks into position. This will indicate that you are in the Economy Water Usage Setting. Pressure switch does not have to be removed to change the setting.

WATER LEVELS	
L	-- 29 Gallons
M	-- 32 Gallons
H	-- 35 Gallons
Washers are shipped from the factory pre-set to 35 gallons, the highest setting.	

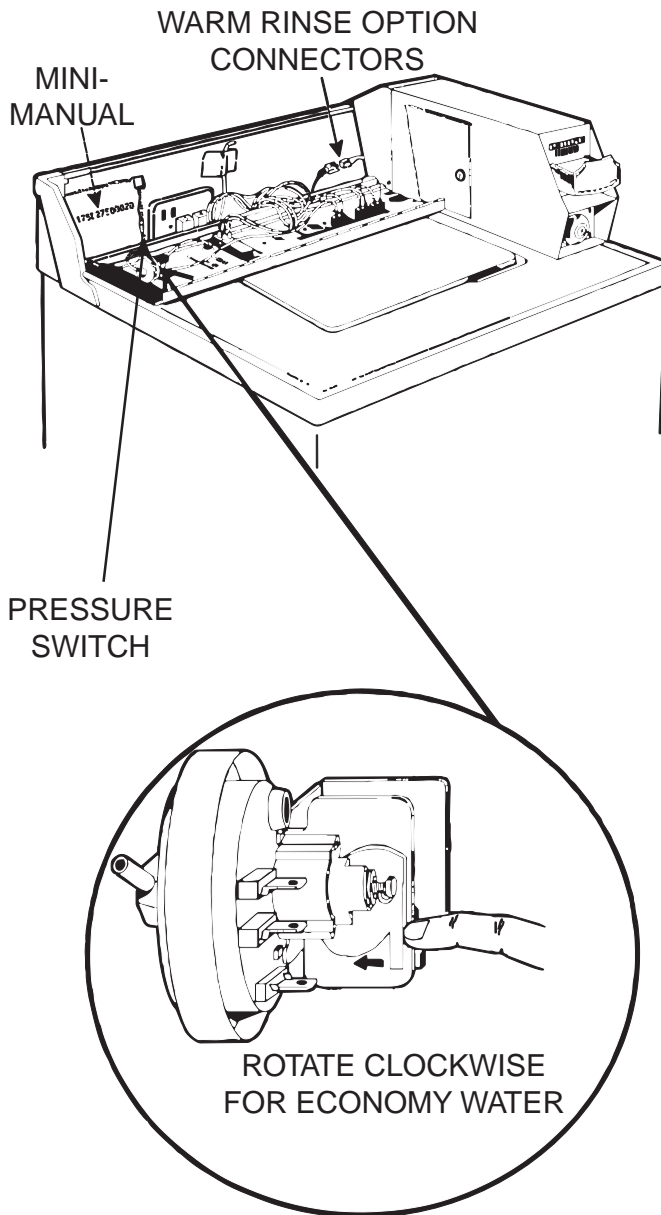

Low Water Consumption Water Temperature			
Cycle Selection	Hot	Cold	Total
Standard Hot Wash	15.5	16.5	32 gallons
Standard Warm Wash	6.1	25.9	32 gallons
Economy Hot Wash	14.4	14.6	29 gallons
Economy Warm Wash	5.6	23.4	29 gallons
Water usage values are determined using a standard AHAM 14 lb. load--water usage may be slightly higher or lower.			

Suspension

The suspension system is unique in that the spin basket, tub, and leg and platform assembly are suspended for the rod support. The rod support sets atop the cabinet and provides, through 4 socket liners durable ball joints. The rod support gives the suspension a pivot point for the rod and spring assembly. A dampening system consisting of 4 dampening straps mounted to the tub cover, dampens rotation movement during start up and braking.

The 4 spring and rod assemblies should be replaced in with the correct part, since the spring compression is different for the front and the back. This is to compensate for the added weight of the motor. The plastic cover over the spring assemblies provides a housing that acts as an air shock, to give proper compression during the movement of the wash action. The spring and rod assembly have been tested to support a weight of 700 lbs. each, to insure a durable suspension system.

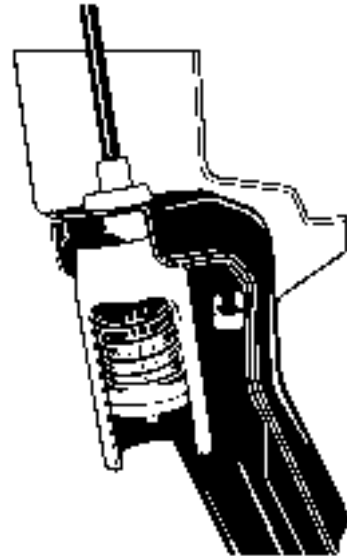

ROD AND SPRING FUNCTIONS AS AN AIR SHOCK (CUT AWAY VIEW)

To Service Suspension

1. Remove front panel. Remove cover and lid.
2. Remove 4 dampening screws front dampeners at tub cover.
3. Remove front rod and spring assemblies. (One at a time), by lifting tub/platform up with one hand to take weight off of suspension bellows.

(NOTE: to remove rod and spring assembly, hold down on ball joint and pull rod forward gently to release.)

4. Using thumb and forefinger to release, pull the bellows out of the platform, and allow to hang freely. Repeat for other side of front.
5. The tub/platform assembly will now lean forward; after both rod and spring assemblies are released. Access the rear spring through the top of the cabinet, and unhook the two rear spring and rod assemblies.

(TECH TIP: Allow the front and back rod and spring assemblies to hang freely, they won't be in your way, and it will keep the proper rod and spring correctly located.)

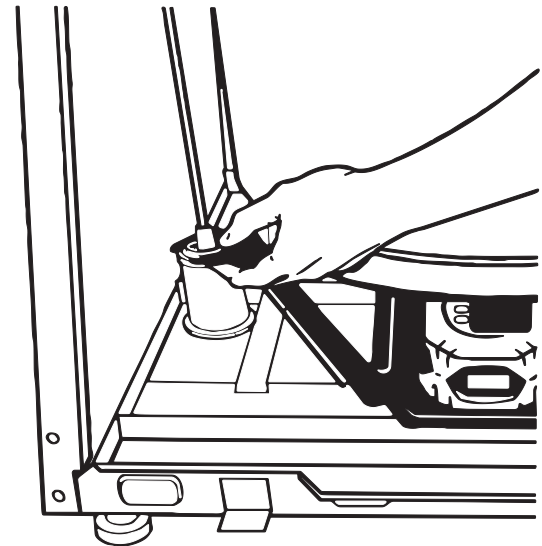

REMOVE ROD AND SPRING ASSEMBLIES IN FRONT

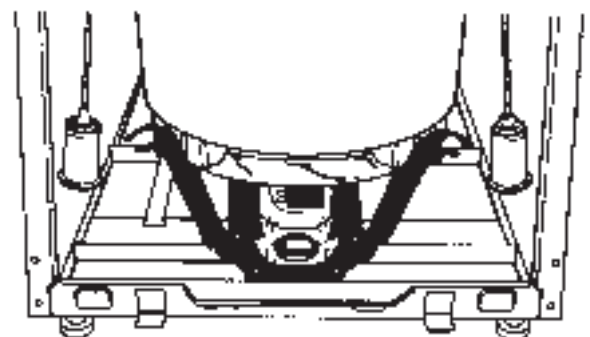

ALLOW ROD AND SPRING ASSEMBLIES TO HANG FREELY

SPIN BASKET

To Service Spin Basket

1. Remove front panel and cover/lid.
2. Disconnect (4) dampening straps from tub, attached by 5/16" hex head screws.
3. Remove tub cover by lifting out 8 tabs on tub cover, and pulling cover off.
4. Remove agitator by grasping bottom and sharply pulling up, or use agitator removal strap as shown.
5. Remove 7/16" hex bolt attaching air bell coupling to transmission spline shaft.

(Tech Tip: The 7/16" bolt has an "O" ring and should be replaced every time it is removed to maintain air bell seal.)

6. Remove left-handed 1- 11/16" transmission hub nut. This nut is aluminum, take care not to round the edges when removing or replacing. **(Note that the word "LOOSEN" with an arrow showing turn to the LEFT appears on the nut.**
7. Lift tub / basket / platform forward to allow clearance to remove basket.
8. Lift basket out and set it aside.

(NOTE: You may hear water in balance ring. This is sealed and is normal.)

9. Replace the basket by reversing procedure.

(TECH TIP: When replacing hub nut, tighten snug, then tighten 1/4 turn with hammer and tool.)

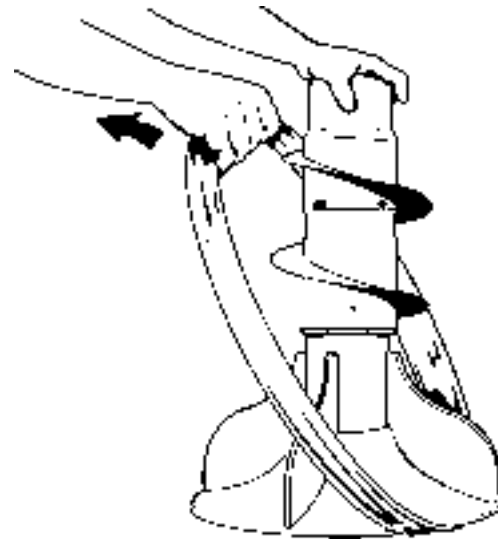
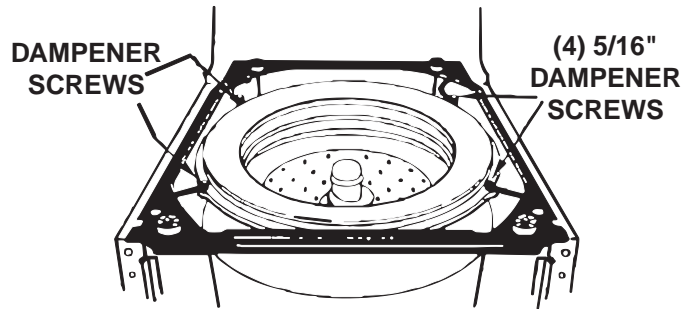

REMOVE AGITATOR

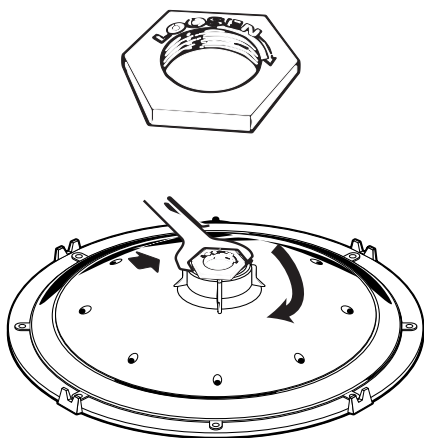

REMOVE HUB NUT

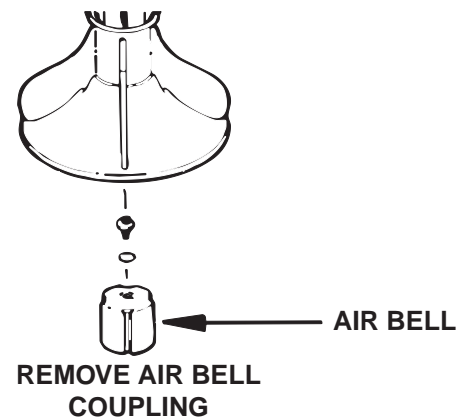

TUB/MOTOR ASSEMBLY

To Service Tub/Motor Assembly

1. Remove front panel, cover/lid, remove agitator by using belt tool, insert under agitator and pull up sharply.
2. Remove split ring and washer from transmission.
3. Remove front rod and spring asm. (one at a time) by lifting motor tub assembly up to take weight off suspension bellows at lower portion of the rod. Pull the bellows out of the leg and platform asm., and allow them to hang freely. The front and the rear rod and spring assembly have different springs that are color coded and shouldn't be switched.
4. The motor and tub assembly will now lean forward after both front suspension rods are removed.
5. Disconnect motor harness connector, and grounding wire to frame, pressure switch hose at takeoff. Save plastic ties to redress hoses as shown.
6. Disconnect hose from bottom of tub to pump.
7. Lift and push bottom of tub/motor assembly towards the rear, and roll top of tub out under top lip of cabinet.

NOTE: An alternate method is to lift complete assembly by the platform at the bottom and set it out first, pulling the assembly out the front. The tub is flexible and can be rolled out under the cabinet frame.

8. Roll tub out per illustration.
9. Pull tub out of apron by tilting it over on its top as shown in illustration
10. Reverse steps to reassemble.

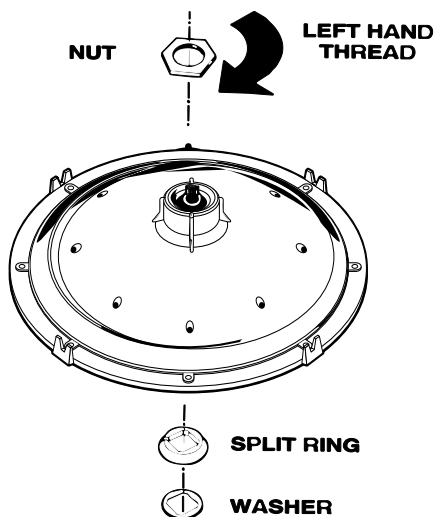

PULL TOP OUT FRONT

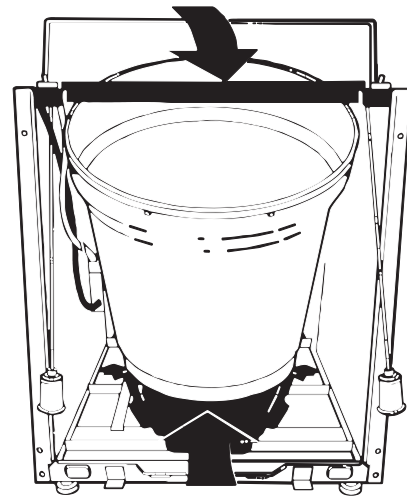

PUSH BOTTOM IN

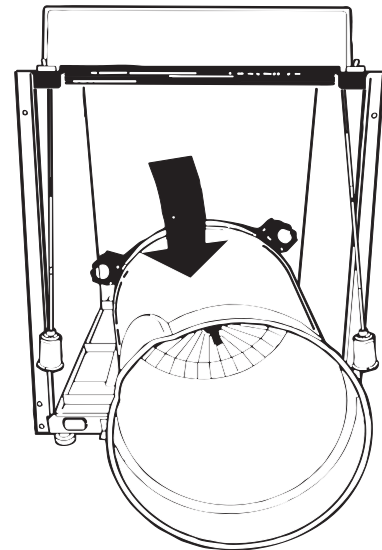

TILT TUB OUT FRONT

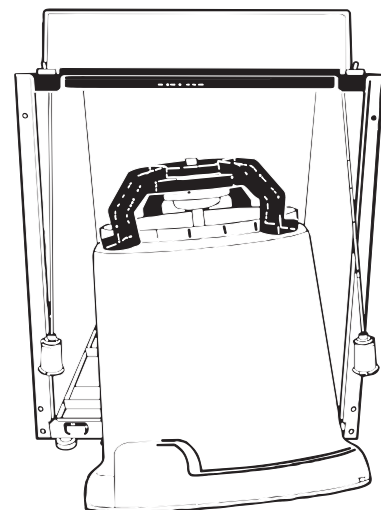

SET TUB UP AS SHOWN
(ALTERNATIVE METHOD IS
REVIEWED IN TEXT AT LEFT)

PUMP

To Service Tub Seal

1. Remove basket as previously shown.
2. Using channel locks, grasp 1 of the four tabs molded into the top of the seal, and pull the seal out.
3. Position new seal and seat, tap or push the seal into place, making sure seal is fully seated.
4. Reverse steps to replace basket.

To Service Remote Pump

1. Remove front panel.
2. Pump is located in lower right front corner of cabinet. Disconnect harness connectors, pinch off black sump hose to prevent water leakage, remove external drain hose clamp and hose, and black sump to pump drain hose clamp and hose.
3. Remove 2- 1/4" hex screws in the front of pump and lift out pump.
4. Reverse steps to replace pump.

(TECH TIP: When a foreign object is removed from the pump, the front fan blade will rotate easily.)

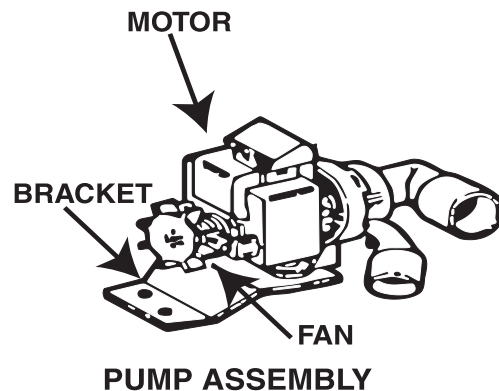
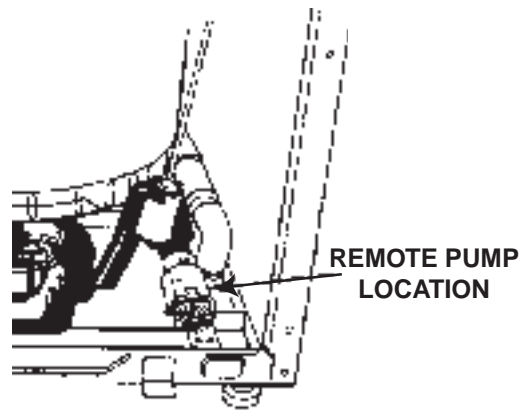

MOTOR/CLUTCH

To Service Motor/Clutch

1. Remove front panel, access motor and clutch from front
2. Loosen (4) 3/8" nuts on leg and platform asm.
3. Move motor towards the center of the platform to release belt tension, and remove belt.
4. After removing 4 motor mount bolts, rotate transmission to a position that allows you enough clearance to pull the motor out by moving the bottom forward to allow the assembly to clear the platform.
5. The clutch is mounted on top of the motor with a one shot removable clutch spring clip that engages flats in the motor shaft. To remove the clutch, remove the clip and lift the clutch up.
6. Reverse and repeat previous steps to reassemble.

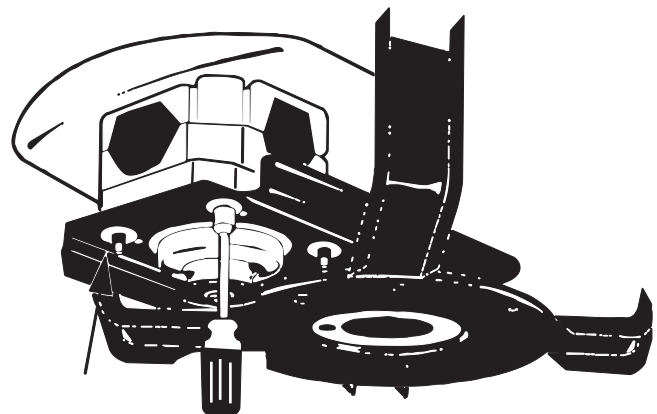

REMOVE (4) 3/8" NUTS ON MOTOR TO LEG AND PLATFORM

Clutch

To Remove Clutch:

Clutch can be ordered as a repair part, and is not shipped with the motor. A common clutch is used for both single and two speed motors.

1. Remove non reusable spring clip by grasping clip with pliers, as shown in illustration, and rotate to remove.
2. To reinstall, place clutch over motor shaft until it is seated. Align clip so that the clip bottom aligns with flats in motor shaft.
3. Rotate and squeeze to install

(TECH TIP: To reassemble use method shown in illustration, place and align a new spring clip in the position shown, and roll the clip into place.)

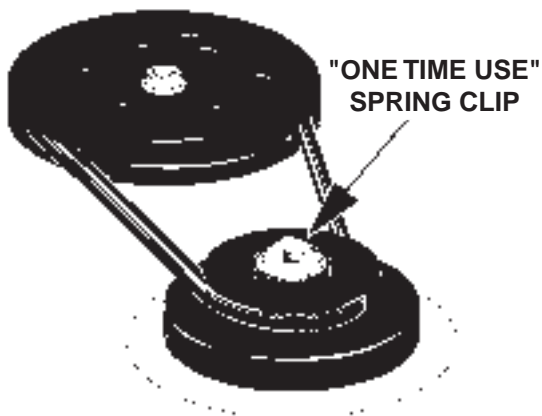

NOTE: Belt tension is about 1/2" deflection when installed. This can be check by flexing the belt between the thumb and forefinger and pushing the two sides of the belt towards the center for a total movement of approximately 1/2"

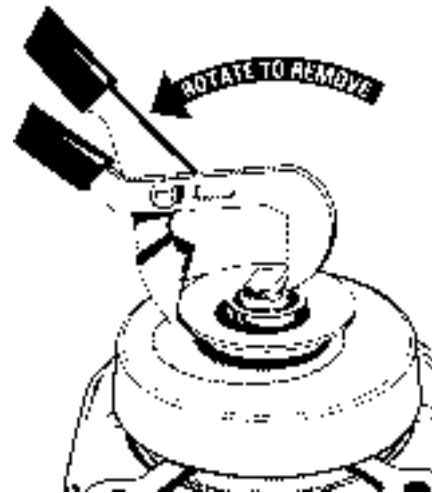

INSTALL SPRING CLIP

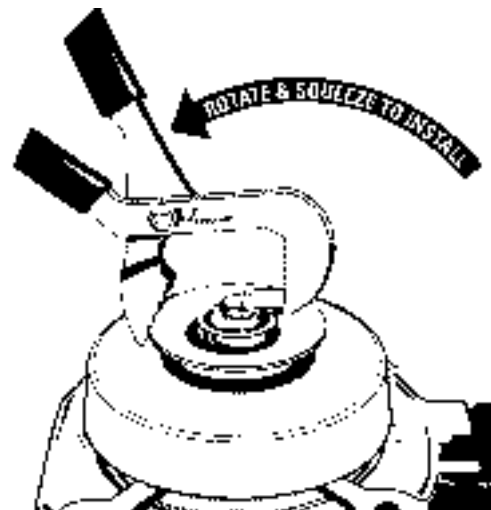

INSTALL SPRING CLIP

Transmission

To Service Transmission:

1. with motor/tub/transmission assembly upside down, loosen motor mounts to release belt tension.
2. Remove transmission drive pulley by holding belt together as shown. Remove pulley nut. (1 3/4")
3. After pulley is removed, remove (4) 3/8" bolts mounting the transmission mounting plate to leg and platform assembly.
4. Remove (4) 1/2" hex bolts mounting platform and leg assembly to tub. Remove wire tie fastening overflow tube.
5. Remove leg and platform support.
6. Lift transmission up and out. Transmission/brake assembly is one component, and is replaced as a single component. Transmission assembly is not technician serviceable.
7. Reverse and repeat steps 1-6 to replace transmission/brake assembly.

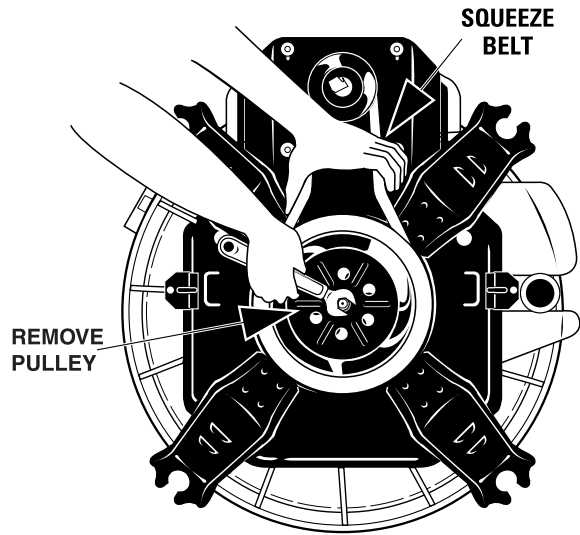

LOOSEN 3/4" NUT FROM PULLEY

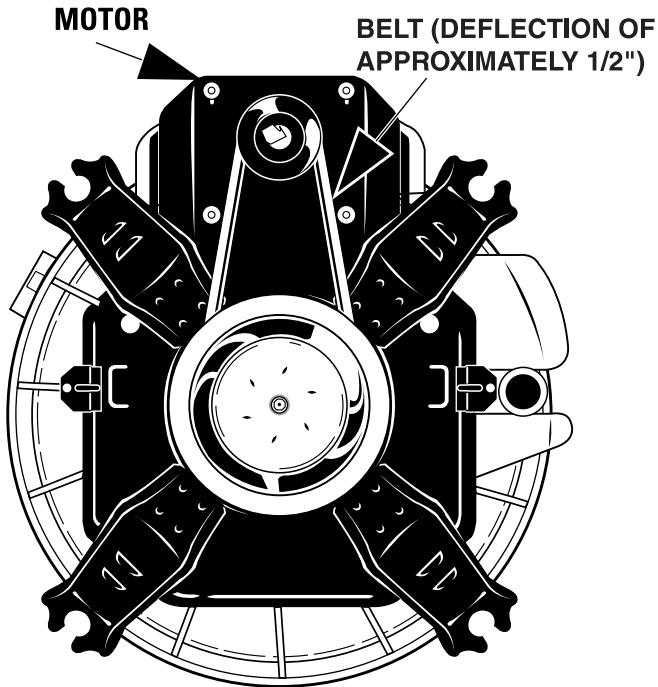

PULLEY DETAIL

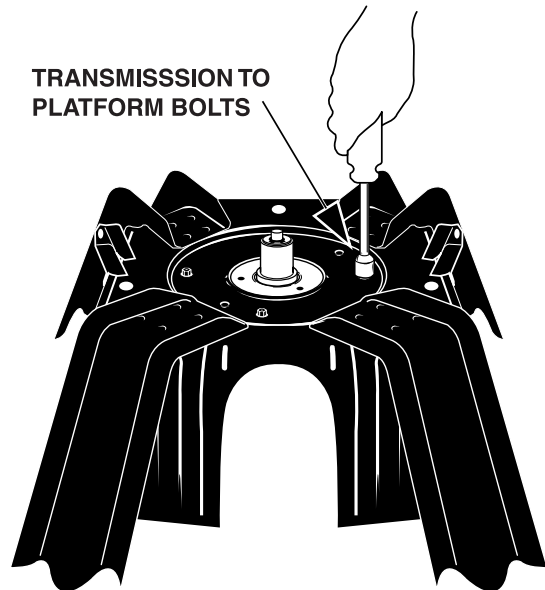

REMOVE 4 3/8" BOLTS MOUNTING TRANSMISSION TO PLATFORM



Transmission (con't.)

NOTE: Transmission cutaway view below is shown to provide you with a glimpse of the internal workings of this rotating transmission. It features all metal gears, metal counterweight, and 5.5 oz. of oil. The transmission and quiet brake are one component, and is replaced and not rebuilt.

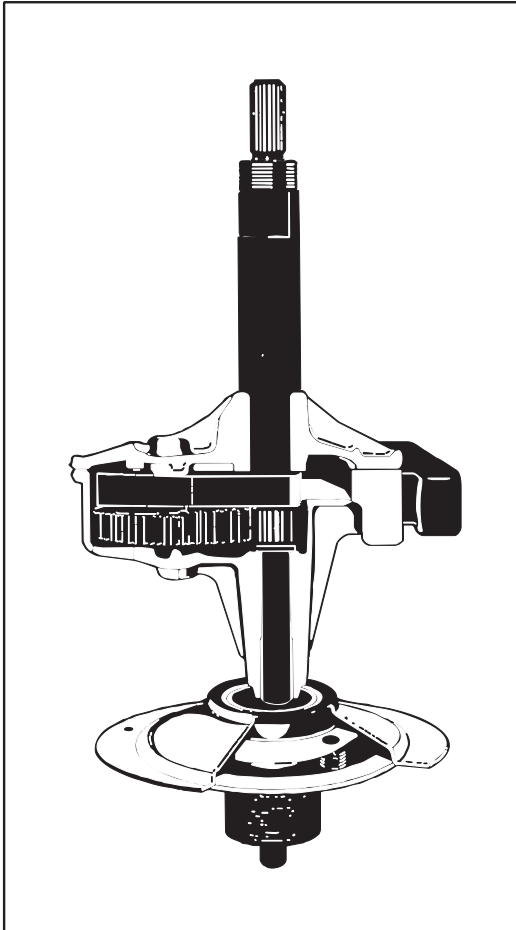

CUTAWAY VIEW OF ROTATING TRANSMISSION

New Transmission provides durability with its all-metal gears. There are no plastic gears to wear or break. All-metal gears provide more durability than plastic gears of the same size. These metal gears allow for a smaller and more balanced transmission. Agitation is accomplished by turning the transmission in a clockwise motion. Spin speeds occur when the transmission is spun or rotated in a counterclockwise motion. A triple lip seal with garter spring provides tub seal system. Care must be taken to make sure garter spring is in place when replacing transmission. The tub bushing is an oil impregnated type, and is not replaceable. It is molded in place at the factory.

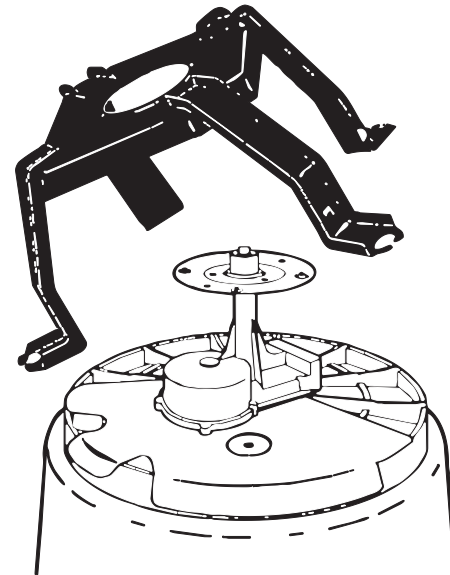

REMOVE PLATFORM

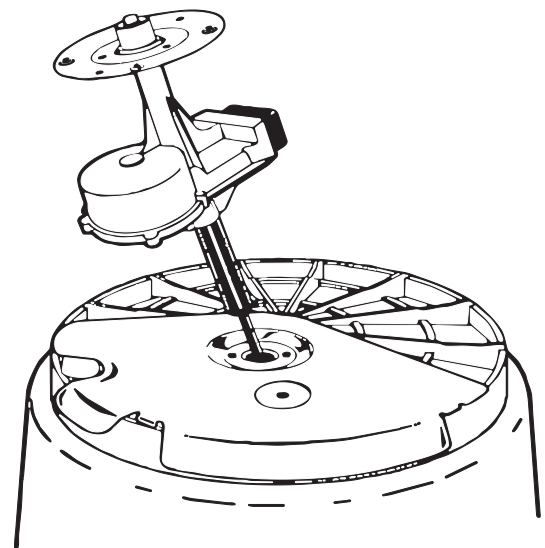

REMOVE TRANSMISSION

SCHEMATIC

CAUTION: TO SERVICE MACHINE, POWER MUST BE DISCONNECTED

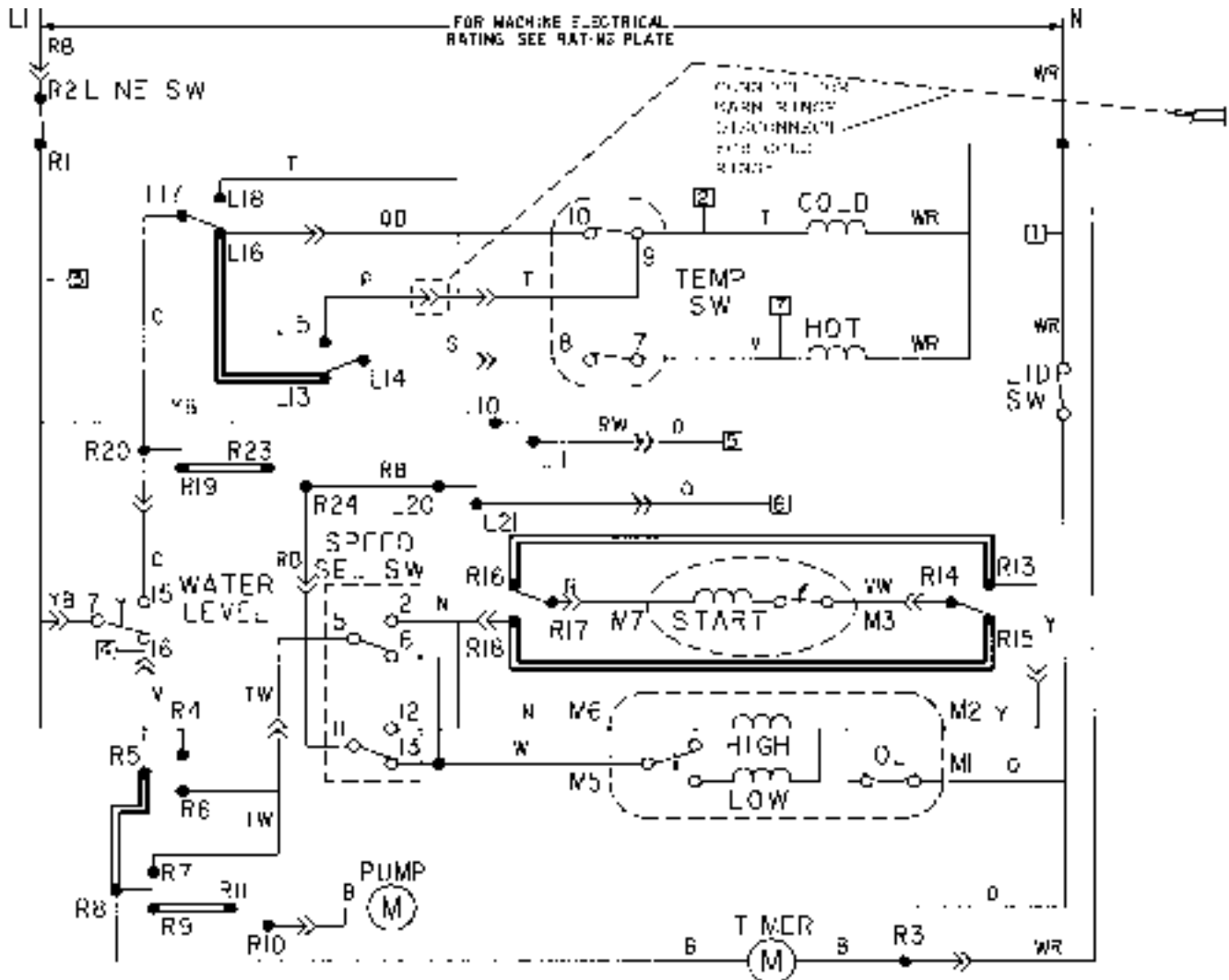

NOTE: CONTROL SWITCHES IN SCHEMATIC ARE SHOWN SET FOR NORMAL WASH. START OF AGITATION BY THE CAM CHART. MANUAL SWITCHES IN SCHEMATIC ARE SHOWN SET FOR PERV PRESS TEMP AND LOW SPEED SELECT. ON NUMBERS AND LETTERS INDICATE CORRESPONDING COMPONENT TERMINAL DESIGNATIONS. DOUBLE LINES \Rightarrow INDICATE BUSSING INSIDE TIMER AND SELECTOR SWITCH.

- SWITCH CONTACT
- TIMER SW. ARM
- BUSS TERM
- » PARALLEL CONNECTOR
- PC BOARD TERMINAL

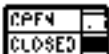

TEMP SEL SW		TERMINALS			
		2-5-6-5	8-7-10-9	11-2-13	
HOT/COLD	F/F				
WARM/COLD	F/F				
WARM/COLD	F/S				
COLD/COLD	S/S				
COLD/COLD	F/F				

COLOR	SYW
BLACK	B
BROWN	C
RED	R
ORANGE	O
YELLOW	Y
GREEN	G
DK. BLUE	M
LT. BLUE	A
VIOLET	V
GRAY	S
WHITE	W
TAN	T
PINK	P
BARE	X

NOTE: This schematic is a full featured model, and the schematic/cam charts do not cover all models. For your particular models. See the instructions on page 3 on accessing the Mini- Manual, located in every washer backsplash, with up to date information on servicing that washer.

SCHEMATIC

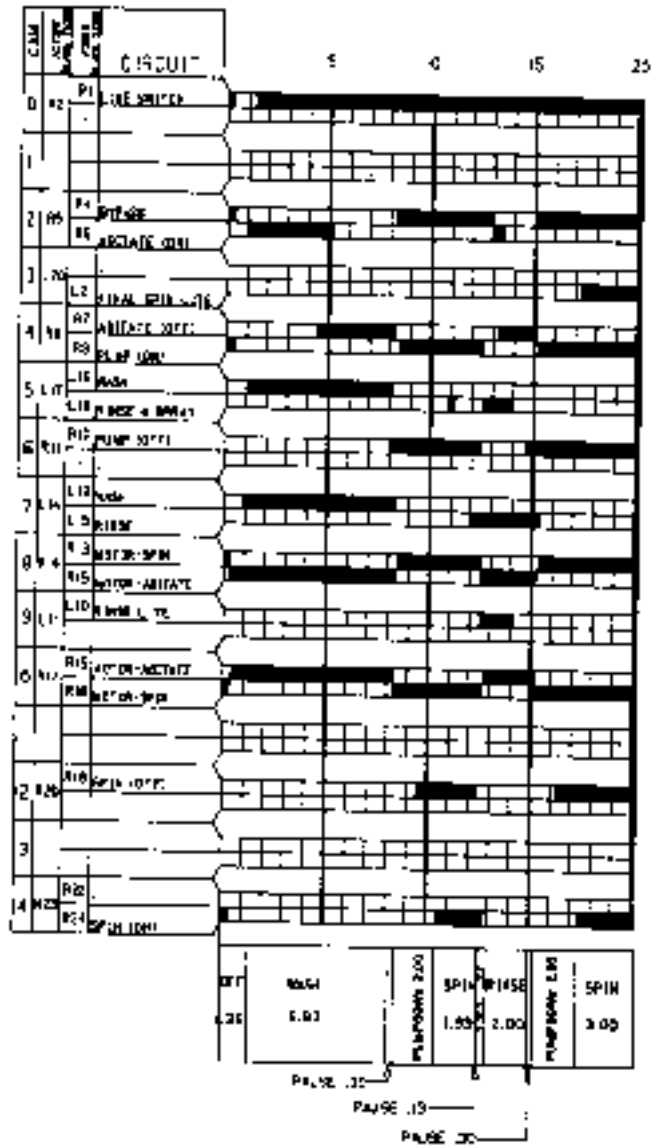

PUB# 31-153778

CAUTION: THIS MACHINE MUST BE ELECTRICALLY GROUNDED.

IT CAN BE GROUNDED THRU THE GROUNDING LEAD IN THE 3 PRONG POWER CORD IF PLUGGED INTO A PROPERLY GROUNDED APPLIANCE OUTLET OR THRU A SEPARATE #8 OR LARGER WIRE FROM THE CABINET TO AN ESTABLISHED GROUND. IN ALL CASES THE GROUNDING METHOD MUST COMPLY WITH ANY LOCAL ELECTRICAL CODE REQUIREMENTS.

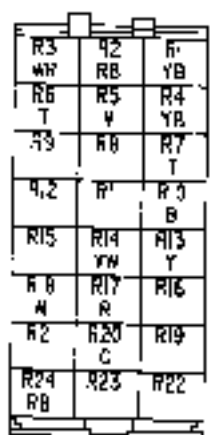
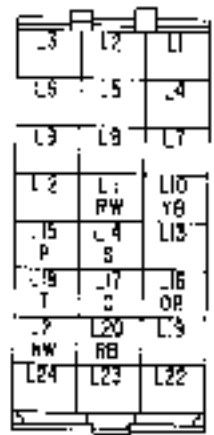

MODELS:

WCCD1030YOAC

WCCD1030YOWC

WLCD1030YOAC

WLCD1030YOWC

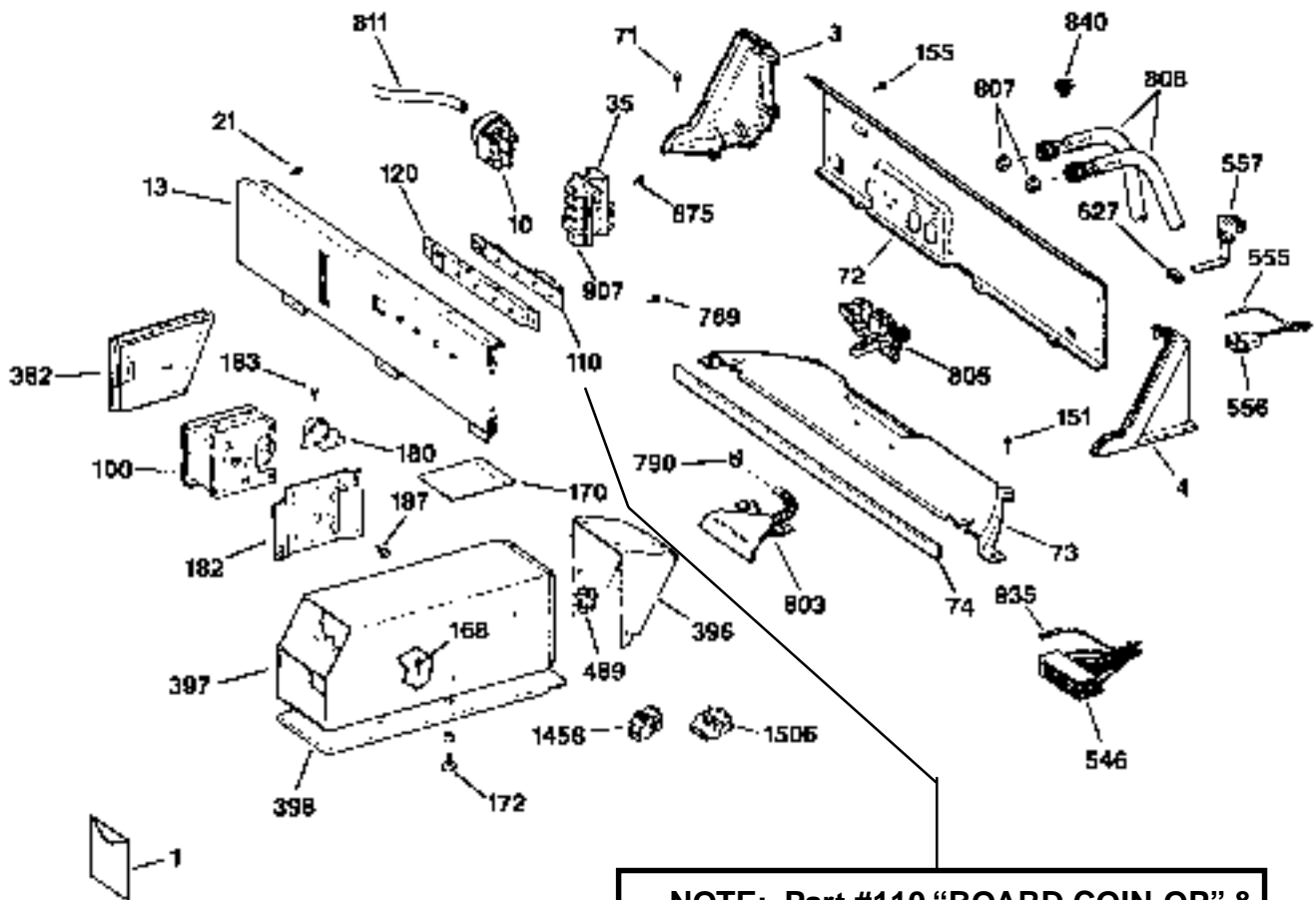

(ART NO. WH625E) C

NOTE: Part #110 "BOARD COIN-OP" & Part #120 "PcB Cover COIN-OP" are shipped as one (1) part.

NOTE: ALL CATALOG NUMBERS WITH APREFIX OF * ARE CATALOG NUMBERS OF GREENWALD INDUSTRIES INC. FOR INFORMATION RELATIVE TO THE GREENWALD PARTS, CONTACT YOUR COIN LAUNDRY DEALER OR GREENWALD IND. INC. 1330 METROPOLITAN AVE. BROOKLYN, NY. 11237 TELEPHONE 1-800-221-0982

MODELS:

**WCCD2050YOAC
WCCD2050YOWC
WLCD2050YOAC
WLCD2050YOWC**

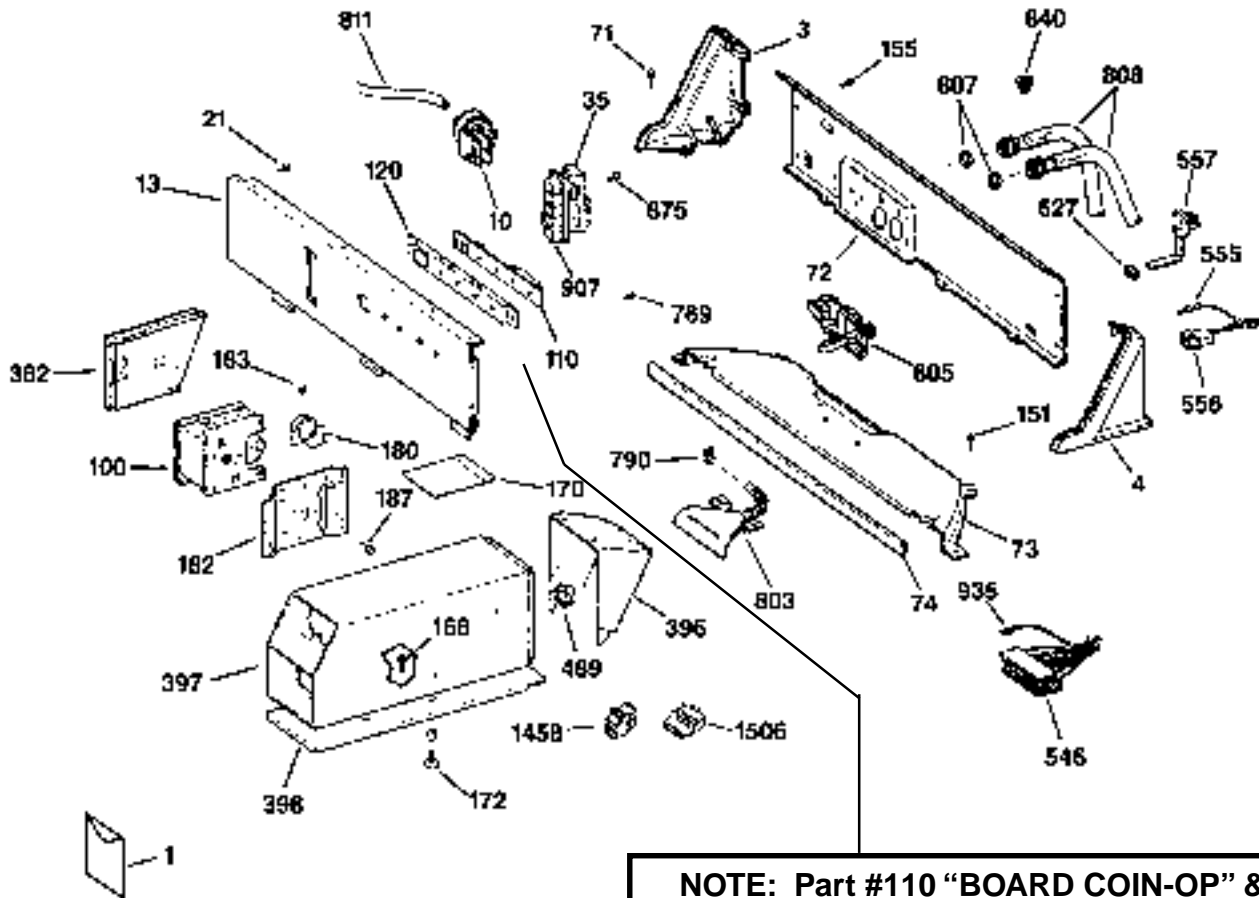

(ART NO. VM6266) C

NOTE: Part #110 "BOARD COIN-OP" & Part #120 "PcB Cover COIN-OP" are shipped as one (1) part.

NOTE: ALL CATALOG NUMBERS WITH APREFIX OF * ARE CATALOG NUMBERS OF GREENWALD INDUSTRIES INC. FOR INFORMATION RELATIVE TO THE GREENWALD PARTS, CONTACT YOUR COIN LAUNDRY DEALER OR GREENWALD IND. INC. 1330 METROPOLITAN AVE. BROOKLYN, NY. 11237 TELEPHONE 1-800-221-0982

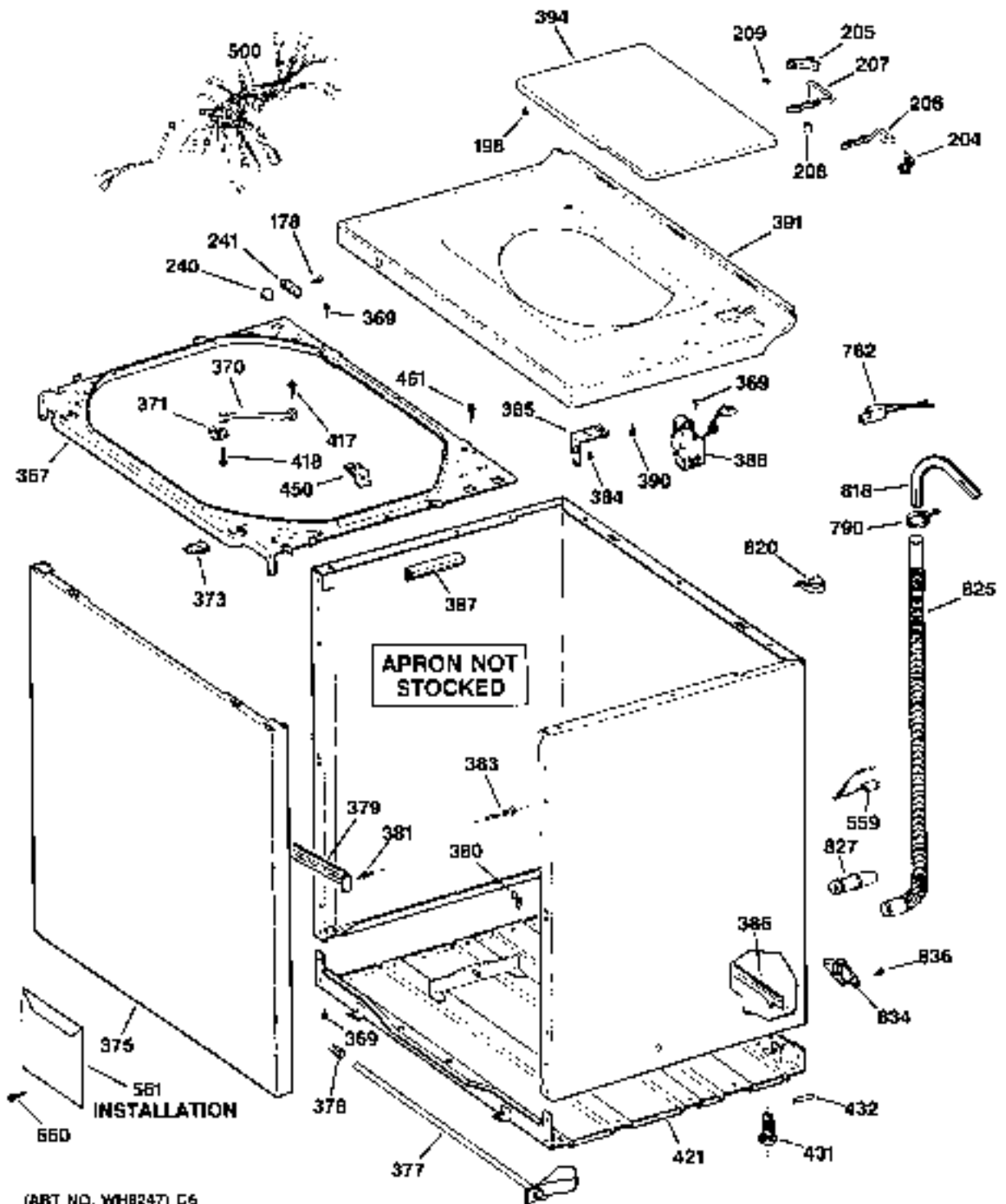

(ART NO. WHB247) C6

WH49X0301 DRAIN HOSE EXT. KIT

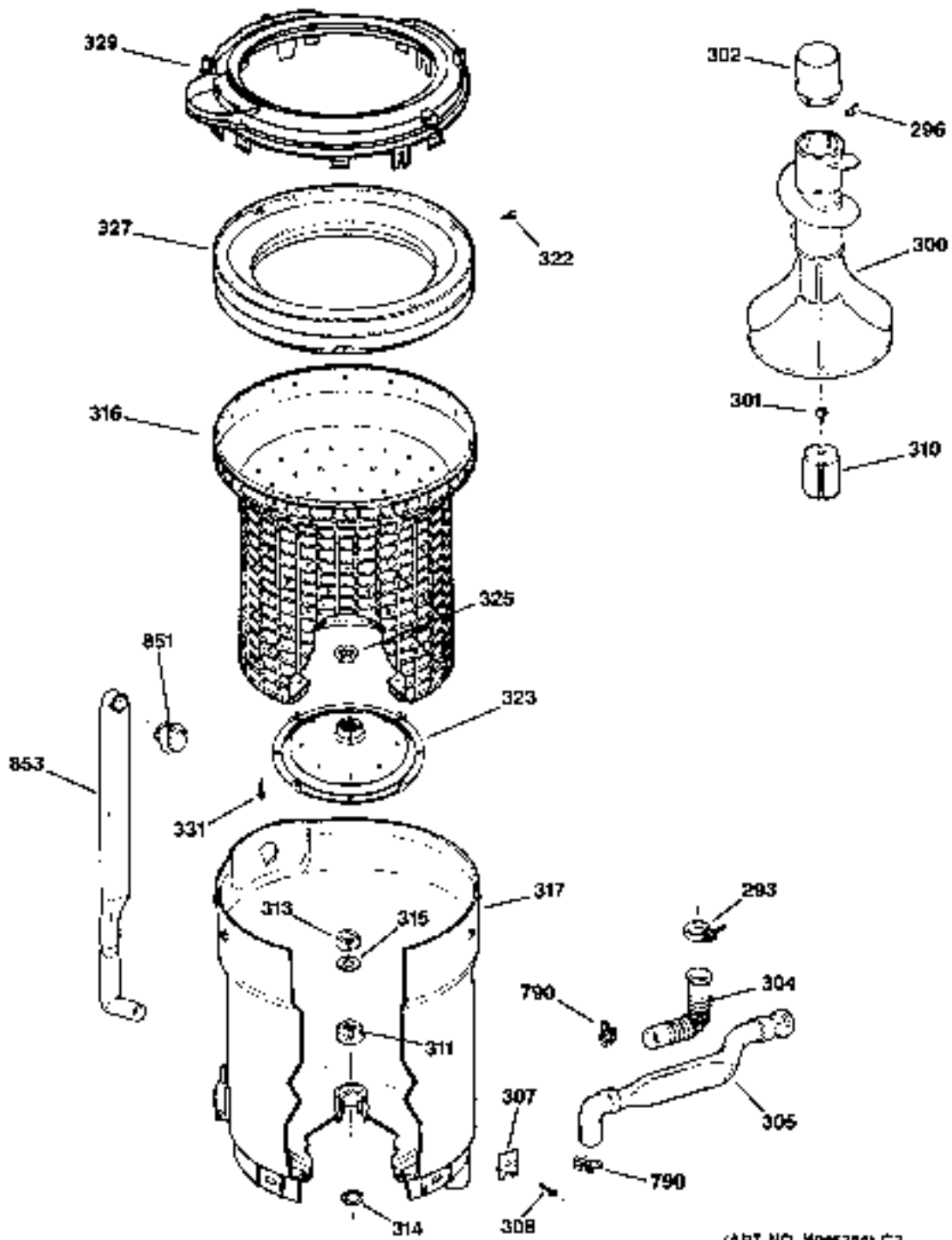

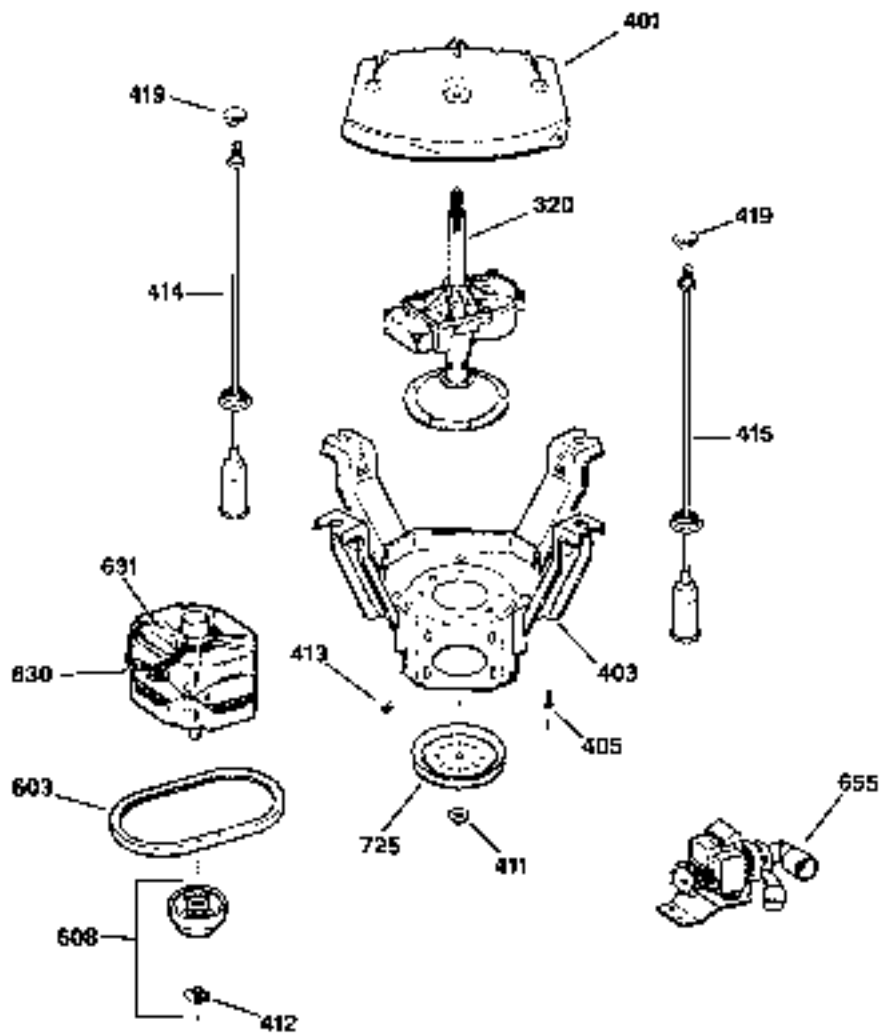

NOTE; REF. 412 (WH1X2733) SHOULD BE REPLACED EACH TIME CLIP IS REMOVED.

(ART NO. WM6266) C

GE Illustrated Parts Catalog
 GE - WCCD2050V0WC

Ref No	Part Number	Description	Qty
1	31-15404	PM INSTRUCTION INSTALL	1
1	49 9956	PM MANUAL USE & CARE	1
1	31-15378	PM SHEET MINT MANUAL	1
3	WH42X2397	END CAP LH WHI	1
4	WH42X2398	END CAP RH WHI	1
10	WH12X10870	SWITCH PRESSURE	1
13	WH42X10190	CONTROL PANEL ASM	1
21	WH02X1185	SCR 8-18 B THW 5/16 S	2
35	WH12X1058	SWITCH PUSHBUTTON ASM	1
71	WH02X1305	SCR 8-18 B 1/2 HEX F	4
72	WH46X10335	PANEL BACK	1
73	WH46X10240	COVER BOTTOM	1
74	WH03X0379	GASKET BACKSPLASH	1
100	WH12X10921	TIMER COIN-OP	1
110	WH12X10580	BOARD COIN-OP	1
120	WH01X10972	PCB COVER COIN-OP	1
151	WH02X1210	SCR 6-18 R THW 1/2 R N	2
155	WH02X1233	SCR 8 18 AB TRT 5/8 S	13
166	WH02X03468	SCR 10 32 M HS 1/8 S	2
170	WH43X0264	ENVELOPE ASM LOCKDOWN	1
172	WH02X1234	SCR 1/4-20MAC FMT .95	1
178	WH02X0939	SCR 6-19 PT EX 1/4 S	1
180	* 72 33 4	CLUTCH ASM	1
182	* 74-05	BRACKET TIMER	1
183	5-32X5/16	SCREW-CAP	1
187	WH02X0948	SCR 10 32 M HW 1/4 S	3
198	WH01X2722	BUMPER LID	2
204	WH01X2741	BUSHING HINGE (SINGLE)	1
205	WH01X10025	BUSHING HINGE (DOUBLE)	1

GE Illustrated Parts Catalog
 GE - WCCD2050Y0WC

Ref No	Part Number	Description	Qty
236	WH01X2733	WIREFORM HINGE	1
237	WH01X15033	WIREFORM HINGE	1
238	WH01X2742	BUMPER HINGE	1
239	WH02X1211	SCREW	4
240	WH01X2266	BUTTON PLUG	1
241	WH01X2266	RETAINER BUTTON	1
293	WH01X2753	CLAMP TUB OUTLET	1
296	WH01X2784	CLIP AGITATOR CAP	3
350	WH43X0142	AGITATOR ASM MULTI	1
331	WH02X10037	SCR 1/4-20 MCH 5/8 S	1
332	WH43X10014	CAP AGITATOR SHORT	1
334	WH41X0371	HOSE DRAIN INLET (TUB TO	1
335	WH41X0374	HOSE DRAIN ASM	1
337	WH01X2730	CLAMP TUB	4
338	WH03X1209	SCR 5/16-18 TPI 1HW 3 N	4
310	WH43X10009	COUPLING AGITATOR	1
311	WH03X1196	SEAL TUB	1
313	WH02X1195	RING SPLIT	1
314	WH02X1197	WASHER TUB BEARING	1
315	WH02X1199	WASHER HUB	1
316	WH45X10016	BASKET LARGE	1
317	WH45X10023	TUB ASM LARGE	1
320	WH38X10032	TRANSMISSION & BRAKE ASM	1
322	WH02X1194	SCREW	7
323	WH45X10027	HUB	1
325	WH02X1193	NUT HUB	7
327	WH45X0152	BALANCE RING ASM	1
329	WH45X10032	COVER TUB	1
331	WH02X10001	SCR 14-10 A TRT 7/8 S	8

GE Illustrated Parts Catalog
 GE - WCCD2050Y0WC

Ref No	Part Number	Description	Qty
367	WH46X0354	WELD ASM RCD SUPPORT	1
369	WH02X1217	SCR 6-18 AB ISW 7/16 SN	31
370	WH01X10346	STRAP DAMPING	4
371	WH01X2726	RETAINER STRAP	4
373	WH02X10050	CLIP LOCKING	2
375	WH46X0345	PANEL FRONT WE	1
375	WH46X10042	PANEL FRONT ASM WE	1
377	WH46X0344	BAR SHIPPING	1
378	WH01X2745	BUTTON PLUG	1
379	WH16X0519	BRACE	1
380	WH02X1207	CLIP GROUND	1
381	WH02X1190	STUD GROUNDING	1
382	WH42X2507	DOOR METER CASE WR	1
383	WH02X1189	PIN ALIGNMENT	4
384	WH02X1212	SCR 6-20 B TRT 3/8 S	2
385	WH01X2723	COVER CLIP	2
386	WH46X0352	BAR SELF LEVELING	1
387	WH41X10036	CONDUIT PRESS SW HOSE	1
388	WH12X1051	LID SWITCH ASM	1
390	WH01X2724	ISOLATOR	6
391	WH44X1218	COVER ASM FINISHED WH	1
394	WH41X10019	LID ASM FINISHED	1
396	WH42X2506	ADAPTER METER CASE WH	1
397	WH42X2508	METER CASE WH	1
398	WH08X10006	GASKET COIN BOX WASHBR	1
401	WH45X10025	SHIELD TUR	1
403	WH17X10000	LEG & PLATFORM WELD ASM	1
405	WH02X1201	SCR 1/4-20 R HWX 3/4 SWS	4
411	WH02X1203	NUT PULLEY	1

GE Illustrated Parts Catalog
 GE - WCCD2050Y0WC

Ref No	Part Number	Description	Qty
412	WH01X2735	CLIP CLUTCH SPRING	1
413	WH02X1204	NUT MOTOR HEX	4
414	WH16X2544	ROD & SPRING ASM	2
415	WH16X2543	ROD & SPRING ASM	2
417	WH02X0694	SCR 10-12 A HEX 1/2 S	4
418	WH02X10803	SCR 8-16 B HEX 1 S	8
419	WH01X10591	SOCKET ROD SUPPORT	4
421	WH46X10024	BASE ASM	1
431	WH02X1187	LEF LEVELING	4
432	WH02X1188	PIN ROLL	2
450	WH16X0928	NUT BRACKET ASM	1
461	WE05X0158	SCREW 8-32X3/8 GRD SCR	1
485	WH01X2572	SLEEVE SPLIT	1
494	W001X1459	INSULATOR HSNM TERM	1
530	WH19X10812	HARNES WASHER COTN OP	1
546	WH12X0870	HOUSING TERMINAL BK	1
550	WH12X0497	HOUSING TERMINAL	1
557	WH19X0307	CORD POWER ASM	1
558	WH12X0548	HOUSING TERMINAL	1
551	WH03X10016	PK PACK ASM INSTALLATION	1
603	WH01X2026	BELT	1
608	WH05X0253	CLUTCH ASM	1
627	WE12X19025	STRAIN RELIEF	1
630	WH25X13039	MOTOR ASM 2 SPD KH-E	1
642	WE12X1959	HOUSING SPECIAL	1
655	WE23X13033	PUMP AND BRACKET ASM	1
725	WH07X0126	PULLEY TRANSMISSION	1
769	WB01X0500	SCR 8-18 B HEX 1/4 S	4
782	WH17X5060	TERMINAL BLK ASM (2 PIN)	1

GE Illustrated Parts Catalog
 GE - WCCD2050Y0WC

Ref No	Part Number	Description	Qty
790	WE01X2006	CLAMP HOSE	1
790	WE01X2006	CLAMP HOSE	1
790	WE01X2006	CLAMP HOSE	1
803	WE41X10037	HOSE & WATER INLET	1
807	WE16X10004	WATER VALVE ASM	1
807	WE02X0042	HOSE WASHER	2
808	WE41X10015	HOSE INTAKE ASM	2
811	WE41X0367	HOSE PRESSURE SWITCH	1
818	WE41X0095	NOZZLE DRAIN	1
823	WE01X2725	CLIP ANTI-SIPHON	1
925	WE41X0365	HOSE SPRING ASM.	1
927	WE41X10020	ADAPTER DRAIN HOSE	1
874	WE16X0513	RETAINER HOSE	1
876	WR02X13002	SCR 6-18 AB INWP 7/8 S	2
851	WH01X2733	GASKET FLOOD HEAD	1
853	WH41X0360	HOSE FLOOD	1
875	WH02X0830	SCREW 8-18 AD HEX 3/8	2
907	WD05X0205	PUSHDUCTOR	5
935	WD31X1424	TERMINAL SPECIAL	29
1458	WD17X5073	TERM BLK ASM-1 PIN(1458)	1
1505	WD17X5059	HOUSING SOCKET PKG 3 PIN	1