

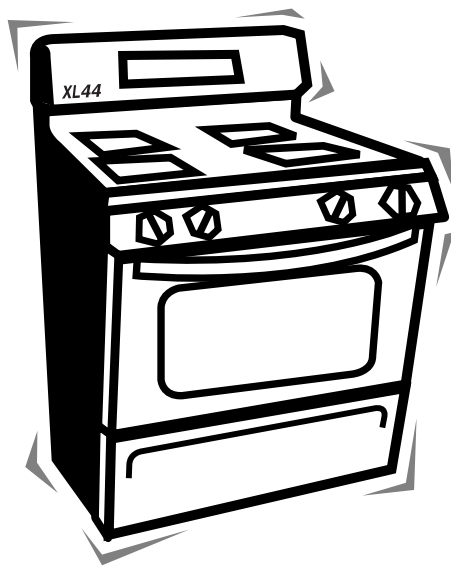

TECHNICAL SERVICE GUIDE

**NEW 30" XL44™ SERIES RANGES
FEATURING TRUETEMP™ COOKING**



MODEL SERIES:

JGBP90 __ A
JGBP86 __ A
JGBP85 __ A
JGBP79 __ A
JGBP35 __ A
JGBP30 __ A
JGBP26 __ A



IMPORTANT SAFETY NOTICE

The information in this service guide is intended for use by individuals possessing adequate backgrounds of electrical, electronic and mechanical experience. Any attempt to repair a major appliance may result in personal injury and property damage. The manufacturer or seller cannot be responsible for the interpretation of this information, nor can it assume any liability in connection with its use.

CAUTION

To avoid personal injury while servicing this unit, disconnect power before servicing. If grounding wires, screws, straps, clips, nuts, or washers used to complete a path to ground are removed for service, they must be returned to their original position and properly fastened.

Table of Contents

About This Service Guide	2
Outstanding New Features	3-6
New Features / Design	7
Features and Specifications	8-9
Cook Top / Surface Burners	10
Conversion & Orifice information	11-12
Control Panel Access	13
ERC III Special Features	14-15
True Temp™ Design	16
ERC On-Board Diagnostics	17-18
Lock Motor Circuit & Diagnostics	19
Schematics / Strip Circuits / Diagnostics	20-24
Illustrated Parts Information	25-30
Flow Chart - Bake / Broil Circuit	31

TECHNICAL SERVICE GUIDE

NEW 30" XL44™ SERIES RANGES
FEATURING TRUE TEMP™ COOKING



ABOUT THIS TECHNICAL SERVICE GUIDE - FEATURED MODEL

The new XL44™ series of gas ranges encompass over 40 different models. We have selected one model which covers most of the new features and designs reflected in the XL44™, 30" gas series of ranges. For model specific information, refer to the charts included in this Guide, on pages 8 & 9.

This service guide will focus primarily on the NEW changes introduced in the XL44™ series of ranges. What this guide will not cover are features, technology and serviceability that we have previously covered in prior training manuals. If you would like additional information on the XL44™ series of ranges which will not be covered in this manual, refer to the following previously issued training publications

Publication Number	Technical Training Manual Title
31-0303	30" free standing ranges, 1990-91 "N" & "P" models; including XL44™ series and capacity plus models
31-1466	"V" line, XL44™ series
31-1465	Carbon monoxide measurements

XL44™: SELF-CLEANING WITH SEALED BURNERS



**GE Profile™
JGBP85BEA**

- Black on black
- Scratch-resistant glass backguard
- QuickSet V oven controls with digipad entry; auto oven shut-off with override; start pad; delay clean option; and self-clean cool down time display
- Fluorescent cooktop night light
- Frameless glass oven door with Big View window
- Sure Grip handle
- Designer-style control knobs
- One-piece upswept porcelain-enameled cooktop
- Square deluxe cast grates with rubber feet
- One-piece drip pans

JGBP85EA (not shown)

- Almond on almond

JGBP85WEA (not shown)

- White on white

A FULL RANGE OF POWER



When it comes to BTUs, the GE gas range delivers the highs, the lows and everything in between.

YOU DON'T COOK SPAGHETTI THE SAME WAY YOU SAUTÉ MUSHROOMS. You don't want a sauce to boil when it's supposed to simmer. For best results, different foods should be cooked over differing levels of heat. That's why, on GE gas ranges, each burner has its own BTU rating. The high-output burner provides quick heat-up and boiling—faster than the “high-power” burners found on most gas ranges. This burner supplies the intense heat needed for the lobster pot, pasta pan, or wok. At the other end of the spectrum is the ultra-low simmer burner. The simmer burner provides precise temperature control and the consistently gentle heating required for delicate foods or sauces. Between these extremes are two all-purpose burners with a mid-range of power, for cooking over medium heat. It all adds up to a full range of power, to help you control cooking with a greater degree of precision. And GE makes it so easy. Simply choose the burner and heat level best suited to the cooking—Maximum output, Precise simmer, or virtually any point in between.

WHEN IT COMES TO ACCURACY, GE TRUETEMP™ IS RIGHT ON THE MARK

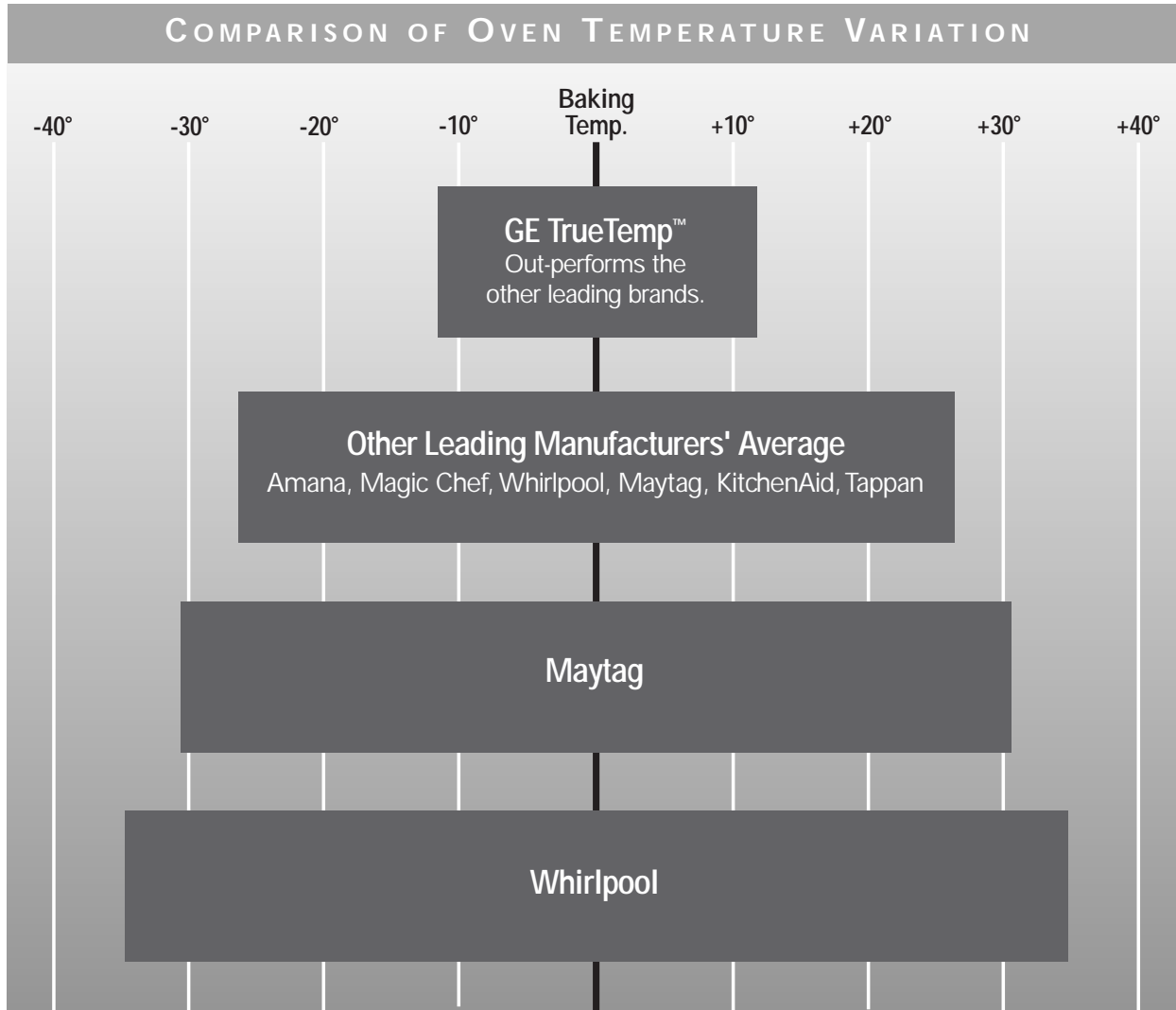

The unique TrueTemp™ System provides a more accurate and consistent heating performance.

GE TRUETEMP™, THE MOST ACCURATE OVEN IN AMERICA!

The guesswork is gone. The temperamental oven is a thing of the past. GE's exclusive TrueTemp™ system manages and maintains the oven temperature you select. It's more accurate than any other leading brand. The SmartLogic™ electronic control, with a platinum sensor, constantly monitors the oven's performance to ensure more precise temperature management. (Even if you open the door when the oven is on, SmartLogic™ senses variations in temperature and responds to regain the selected setting.) The TrueTemp™ system also includes a new enhanced broil system, which distributes heat broadly and evenly for improved cooking performance. QuickSet electronic controls make it easy for you to set the oven temperature and the time for baking or broiling. And the extra-large oven, broiler pan and grid provide the capacity you need when cooking for a crowd.

**Among leading manufacturers: Amana, Magic Chef, Whirlpool, Maytag, KitchenAid, Tappan.*

ONLY GE GAS RANGES HAVE AN APPETITE THIS BIG



A sixth embossed rack position increases cooking flexibility.

THE LARGEST USABLE OVEN CAPACITY IN 30" FREE-STANDING MODELS*

There's more oven space inside the GE 30" free-standing gas range—room for an entree and four casseroles, with space to spare. For baking, you have the flexibility of using as many as six racks, or as few as you wish. QuickSet touchpad controls make it easy to set the oven temperature and baking or broiling time. The oven is self-cleaning, and the range top needs only a wipe with a sponge to keep it shiny and bright. Burners are sealed to the cooktop, to keep spills from running below, and topped with stylish, square cast grates. Naturally, the burners have varying degrees of power, allowing you to choose the one most suitable for sautéing, simmering, heating or boiling. Whether you're hungry for capacity, flexibility or cleanability, no one understands how to satisfy your hunger like the range with the biggest appetite for customer satisfaction.

**Among leading manufacturers' brands.*

WE'VE PUT A NEW SPIN ON A GRATE TOP



GE's professional grate lets you slide hot pans on and off burners without lifting, balancing or spilling.

THE FIRST THING YOU NOTICE IS THE STRIKING DESIGN. A bold, geometric pattern tops off this GE gas range, but there's more to the cooktop than its beauty. The big story here is convenience. The cast-iron platform, made up of two interlocking grates, provides a flat surface for cooking and meal preparation. To switch cookware from one burner to another, you don't have to lift the pans, perform a balancing act, and risk spilling the contents. Just slide the pans from burner to burner. The cooktop design allows you to easily rotate pots and pans as needed—and it's especially helpful when you're handling a larger pot of bubbling soup or stew. The space in the center can be used for preparing foods or for transferring cooked foods to serving dishes. We've even simplified clean-up for you, by making the grates easy to uncouple and remove for washing. Since Americans do most of their cooking on top of the range, it just makes sense to build convenience into the cooktop design. That's the way we see it. And that's the way we've done it, "plain" and simple.

NEW FEATURES / DESIGN

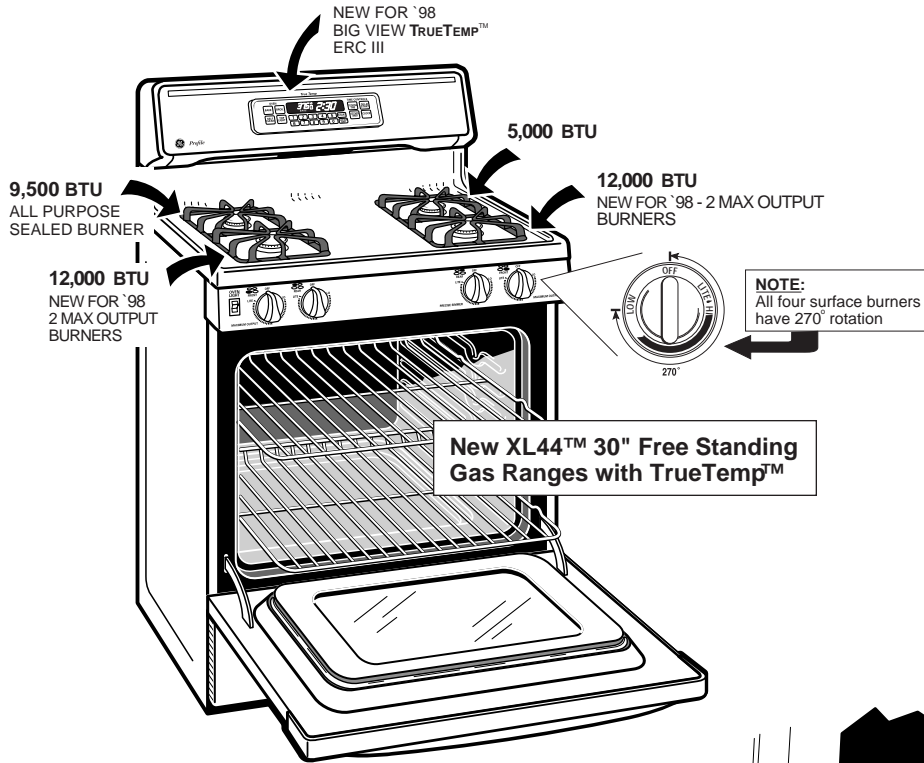

So What's New?

- * Burner configurations
- * Orifice holder design
- * Cooktop Removal
- * TrueTemp™ ERC III
- * Ignitor switch assembly (all four switches in one)

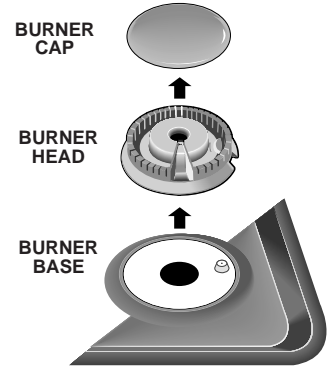

THREE BURNER STYLES

Simmer Burner

- Designed for precise simmering; the simmer burner has an output of 5,000 BTU and a simmer of 600 BTU.

All-purpose Burner

- This burner provides an output of 9,500 BTU with a simmer rate of 850 BTU.

Maximum Output Burner

- The maximum output burner produces up to 12,000 BTU (GE) and 13,000 BTU (KENMORE), with a 1,000 BTU simmer rate for both.

* Burner configurations (BTU ratings)

Burner configurations vary by model and brand. See charts on pages 8 and 9 for specific model features and specifications

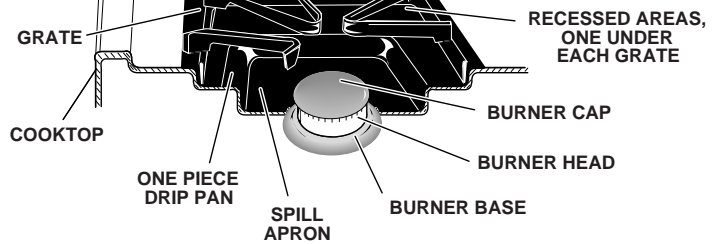

GAS SUPPLY REQUIREMENTS

Gas	Incoming Pressure to Regulator	Pressure Regulator Output supplies
Natural	6.0" to 9.0" W.C.P.	4.0" W.C.P.
L.P.	11" to 14" W.C.P.	10" W.C.P.

GE Profile™

GE



Precise Simmer Burner with 600 BTUs allows for low, even heat distribution for delicate foods and sauces



Two Maximum Output Burners, with 12,000 BTUs, provide high output for fast heat-up and boiling



Largest Useable Oven Capacity,* room for cooking an entire meal

*Among manufacturers' brands



Digipad entry provides digital precision with easy-to-set controls



Enhanced Broil System provides improved broil performance

30" XL44™ SELF-CLEANING GAS RANGES

	GE Profile™				GE								
	Sealed Burner Models				Sealed Burner Models						Standard Burner Models		
	JGBP90MEA	JGBP86WEA JGBP86AEA JGBP86BEA	JGBP85WEA JGBP85AEA JGBP85BEA	JGBP79WEA JGBP79AEA JGBP79BEA	JGBP35WEA JGBP35AEA JGBP35BEA	JGBP30WEA JGBP30AEA	JGBP30BEA	JGBP28BEA	JGBP27BEA	JGBP26WEA JGBP26AEA	JGBP26BEA	JGBP24BEA	
Capacity													
Extra-large oven	•	•	•	•	•	•	•	•	•	•	•	•	
Features													
Oven cleaning	Self-Cleaning	Self-Cleaning	Self-Cleaning	Self-Cleaning	Self-Cleaning	Self-Cleaning	Self-Cleaning	Self-Cleaning	Self-Cleaning	Self-Cleaning	Self-Cleaning	Self-Cleaning	
Cooktop burners	Sealed	Sealed	Sealed	Sealed	Sealed	Sealed	Sealed	Sealed	Sealed	Sealed	Std./Twin	Std./Twin	
Maximum Output burner (Nat.)	(2) 12,000/ 1,000 BTU	(2) 12,000/ 1,000 BTU	(2) 12,000/ 1,000 BTU	(2) 12,000/ 1,000 BTU	(1) 12,000/ 1,000 BTU	(1) 12,000/ 1,000 BTU	(1) 12,000/ 1,000 BTU						
Precise Simmer burner (Nat.)	(1) 5,000/ 600 BTU	(1) 5,000/ 600 BTU	(1) 5,000/ 600 BTU	(1) 5,000/ 600 BTU	(1) 5,000/ 600 BTU	(1) 5,000/ 600 BTU	(1) 5,000/ 600 BTU						
All-purpose burners (Nat.)	(1) 9,500/ 850 BTU	(1) 9,500/ 850 BTU	(1) 9,500/ 850 BTU	(1) 9,500/ 850 BTU	(2) 9,500/ 850 BTU	(2) 9,500/ 850 BTU	(2) 9,500/ 850 BTU	(4) 9,500/ 850 BTU	(4) 9,500/ 850 BTU				
Valves (degree of turn)	270	270	270	270	270	270	270	140	140		270	270	
TrueTemp™ System	•	•	•	•	•	•	•	•	•	•	•	•	
SmartLogic™ controls	•	•	•	•	•	•	•	•	•	•	•	•	
QuickSet oven controls	QuickSet V	QuickSet V	QuickSet V	QuickSet IV	QuickSet IV	QuickSet III	QuickSet III	QuickSet II	QuickSet II	QuickSet III	QuickSet III	QuickSet II	
Auto Self-Clean	•	•	•	•	•	•	•	•	•	•	•	•	
Electronic oven control	•	•	•	•	•	•	•	•	•	•	•	•	
Hi/Low broil	•	•	•	•	•	•	•	•	•	•	•	•	
Electronic clock and timer	•	•	•	•	•	•	•	•	•	•	•	•	
Automatic oven timer	•	•	•	•	•	•	•	•	•	•	•	•	
Audible preheat signal	•	•	•	•	•	•	•	•	•	•	•	•	
Auto oven shut-off	•	•	•	•	•	•	•	•	•	•	•	•	
One-piece upswept cooktop	BC	Porc.-Enam.	Porc.-Enam.	Porc.-Enam.	Porc.-Enam.	Porc.-Enam.	Porc.-Enam.	Porc.-Enam.	Porc.-Enam.	Porc.-Enam.	Porc.-Enam.	Porc.-Enam.	
Lift-up cooktop													
Easy-clean porcelain-enameled subtop													
Porcelain-enameled one-piece drip pans	Black	Grey Taupe Black	Grey Taupe Black	Grey Taupe Black	Grey Taupe Black	Grey Taupe Black	Taupe	Black	Opt. Access.	Opt. Access.	Chrome Grey Std. Porc. Steel Taupe Std. Porc. Steel	Black Std. Porc. Steel	Opt. Access. Black Std. Porc. Steel
Removable square grates	Profes. Grates	Profes. Grates Grey Taupe Black	Grey Dxe. Cast Taupe Deluxe Cast Black Dxe. Cast	Grey Dxe. Cast Taupe Deluxe Cast Black Dxe. Cast	Grey Std. Cast Taupe Std. Cast Black Std. Cast	Grey Dxe. Porc. Steel Taupe Deluxe Porc. Steel	Black Deluxe Porc. Steel	Black Std. Porc. Steel	Black Std. Porc. Steel	Black Std. Porc. Steel	Black Std. Porc. Steel	Black Std. Porc. Steel	
Ignition system	Electronic	Electronic	Electronic	Electronic	Electronic	Electronic	Electronic	Electronic	Electronic	Electronic	Electronic	Electronic	
Oven racks	3	3	3	3	2	2	2	2	2	2	2	2	
Six embossed rack positions	•	•	•	•	•	•	•	•	•	•	•	•	
Extra-large broiler pan/grid	•	•	•	•	•	•	•	•	•	•	•	•	
Scratch-resistant backguard	Mirrored Glass	Glass	Glass	Porc.-Enam.	Porc.-Enam.	Porc.-Enam.	Porc.-Enam.	Porc.-Enam.	Porc.-Enam.	Porc.-Enam.	Porc.-Enam.	Porc.-Enam.	
Fluorescent backguard light	•	•	•	•	•	•	•	•	•	•	•	•	
Interior oven light	•	•	•	•	•	•	•	•	•	•	•	•	
Storage drawer	Easy Glide	Easy Glide	Easy Glide	Easy Glide	•	•	•	•	•	•	•	•	
In-oven broiling	•	•	•	•	•	•	•	•	•	•	•	•	
Appearance													
Color appearance*	BC	WW AA BB	WW AA BB	WW AA BB	WW AA BB	WW AA BB	WH/AD	WH/AD	WH/AD	WW AA	WH/AD	WH/AD	
Frameless removable oven door	Mirrored Glass	White Glass Almond Glass Black Glass	White Glass Almond Glass Black Glass	White Glass Almond Glass Black Glass	White Glass Almond Glass Black Glass	White Glass Almond Glass	Black Glass	Black Glass	Solid Black Glass	White Glass Almond Glass	Black Glass	Solid Black Glass	
Oven door with window	Big View	Big View	Big View	Big View	Big View	Big View	Big View	•	•	•	•	•	
Designer-style handle	Professional-Style	Sure Grip	Sure Grip	Sure Grip	•	•	•	•	•	•	•	•	
Designer-style control knobs	Professional-Style	•	•	•	•	•	•	•	•	•	•	•	
Four leveling legs	•	•	•	•	•	•	•	•	•	•	•	•	
Weights & Dimensions													
Overall oven interior dimensions (WxHxD in inches)	← 24 x 17 x 19 →												
Approx. shipping weight (lbs.)	230	220	220	210	210	210	210	210	210	200	200	200	
Power/Ratings													
Top burners (000's BTU's) Nat/LP	← (2) 12.0/11.0 (1) 5.0/5.0 (1) 9.5/9.5 →				← (1) 12.0/11.0 (1) 5.0/5.0 (2) 9.5/9.5 →			← (4) 9.5/9.5 →		← (4) 9.0/8.0 →			
Oven/broiler burners (000's BTU's) Nat/LP	← 16.0/16.0 Oven 13.5/12.0 Broil →												
Gas range electrical rating	← 120V, 60Hz, 5A →												
LP conversion kit (included)	•	•	•	•	•	•	•	•	•	•	•	•	

*BB = Black on black, WW = White on white, AA = Almond on almond, WH = White, AD = Almond, BC = Brushed-Chrome, CM = Color-matched indicates color of oven door matches cooktop (either White or Almond). Factory set for Natural Gas. A set of LP orifices is included with each XL44™ range for LP conversion.

Optional Gas Range Accessory Drip Pans For Sealed and Standard Burner Models (Available at additional cost)
To order these accessory drip pans, call toll-free 800-848-7722.

Optional Gas Range Wok Accessory (Available at additional cost)
JXWK = Wok holder accessory sits on top of maximum burner grate to hold a round-bottom wok.

Installation Information: Before installing, consult installation instructions packed with product for current dimensional data.



All GE ranges are equipped with an Anti-Tip device. The installation of this device is an important, required step in the installation of the range.

Model	A	B	C*	D	E
JGBP90MEA	30	47-3/4	26-1/4	46-3/8	36 ± 1/4
JGBP86BEA/WEA/AEA	30	47-3/4	26-1/4	46-3/8	36 ± 1/4
JGBP85BEA/WEA/AEA	30	47-3/4	26-1/4	46-3/8	36 ± 1/4
JGBP79BEA/WEA/AEA	30	46-1/2	26-1/4	46-3/8	36 ± 1/4
JGBP35BEA/WEA/AEA	30	46-1/2	26-1/4	46-3/8	36 ± 1/4
JGBP30BEA/WEA/AEA	30	46-1/2	26-1/4	46-3/8	36 ± 1/4
JGBP28BEA	30	46-1/2	26-1/4	46-3/8	36 ± 1/4
JGBP27BEA	30	46-1/2	26-1/4	46-3/8	36 ± 1/4
JGBP26WEA/AEA	30	46-1/2	26-1/4	46-3/8	36 ± 1/4
JGBP26BEA	30	46-1/2	26-1/4	46-3/8	36 ± 1/4
JGBP24BEA	30	46-1/2	26-1/4	46-3/8	36 ± 1/4

*Dimension from wall to front of closed door handle is 29" on models JGBP86/85/79 and 28-1/4" on models JGBP90/35/30/28/27/26/24. 25-1/4"—Depth to front edge of cooktop.

30" XL44™ CONTINUOUS AND STANDARD CLEAN GAS RANGES

	GE											
	Sealed Burner Models			Standard Burner Models								
	JGBS23WEA JGBS23AEA JGBS23BEA	JGBS22BEA	JGBS21PEA	JGBC20BEA JGBS20BEA	JGBC20WEA JGBS20WEA	JGBC17PEA JGBS17PEA	JGBS15PEA	JGBS07PEA	JGBS04BEA JGBS04BPA	JGBS04PEA JGBS04PPA	JGBS03PPA	
Capacity												
Extra-large oven	•	•	•	•	•	•	•	•	•	•	•	•
Features												
Oven cleaning	Standard Clean	Standard Clean	Standard Clean	Cont. Clean Standard Clean	Cont. Clean Standard Clean	Cont. Clean Standard Clean	Standard Clean	Standard Clean	Standard Clean	Standard Clean	Standard Clean	Standard Clean
Cooktop burners	Sealed	Sealed	Sealed	Std./Twin	Std./Twin	Std./Twin	Std./Twin	Std./Twin	Std./Twin	Std./Twin	Std./Twin	Std./Twin
Maximum Output burner (Nat.)	(1) 12,000/ 1,000 BTU											
Precise Simmer burner (Nat.)	(1) 5,000/ 600 BTU											
All-purpose burners (Nat.)	(2) 9,500/ 850 BTU	(4) 9,500/ 850 BTU	(4) 9,500/ 850 BTU									
Valves (degree of turn)	270	140	140	140	140	140	140	140	140	140	140	140
Electronic clock and timer	•	•	•	•	•	•	•	•	•	•	•	•
Porcelain-enameled cooktop	One-Piece Upswept	One-Piece Upswept	One-Piece Upswept	One-Piece Upswept	One-Piece Upswept	One-Piece Upswept	One-Piece Upswept	One-Piece Upswept	•	•	•	•
Lift-up cooktop				•	•	•	•	•	•	•	•	•
Easy-clean porcelain-enameled subtop				•	•	•	•	•	•	•	•	•
One-piece drip pans	Grey Taupe Black	Opt. Access.	Opt. Access.	Opt. Access.	Opt. Access.	Opt. Access.	Opt. Access.	Opt. Access.	Opt. Access.	Opt. Access.	Opt. Access.	Opt. Access.
Removable square grates	Deluxe Porcelain Steel	Black Standard Porcelain Steel	Black Standard Porcelain Steel	Black Standard Porcelain Steel	Grey Standard Porcelain Steel	Black Standard Porcelain Steel	Black Standard Porcelain Steel	Grey Standard Porcelain Steel	Black Standard Porcelain Steel	Black Standard Porcelain Steel	Black Standard Porcelain Steel	1-Piece Wire
Ignition system	Electronic	Electronic	Electronic	Electronic	Electronic	Electronic	Electronic	Electronic	Electronic Pilot †	Electronic Pilot †	Electronic Pilot †	Pilot †
Oven racks	2	2	1	2	2	2	2	2	2	2	2	2
Six embossed rack positions	•	•	•	•	•	•	•	•	•	•	•	•
Extra-large broiler pan/grid	•	•	•	•	•	•	•	•	•	•	•	•
Porcelain-enameled backguard	•	•	•	•	•	•	•	•	•	•	•	•
Interior oven light	•	•	•	•	•	•	•	•	•	•	•	•
Slide-out broiler drawer	•	•	•	•	•	•	•	Drop-Down	•	•	•	Drop-Down
Appearance												
Color appearance*	WW AA WH/AD	WH/AD	WH/AD	WH/AD	WW	WH/AD	WH/AD	WW	WH/AD	WH/AD	WH/AD	WH/AD
Frameless removable oven door*	White Glass Almond Glass Black Glass	Black Glass	CM* Porcelain- Enameled	Black Glass	White Glass	CM Porcelain- Enameled	CM Porcelain- Enameled	White Porcelain- Enameled	Solid Black Glass	CM* Porcelain- Enameled	CM* Porcelain- Enameled	CM* Porcelain- Enameled
Oven door with window	Big View	•	•	•	•	•	•	•	•	•	•	•
Designer-style handle	•	•	Chrome Visor	•	•	•	Chrome Visor	•	•	Chrome Visor	Chrome Visor	Chrome Visor
Four leveling legs	•	•	•	•	•	•	•	•	•	•	•	•
Weights & Dimensions												
Overall oven interior dimensions (WxHxD in inches)	← 24 x 17 x 19 →											
Approx. shipping weight (lbs.)	180	170	170	175	175	175	175	165	165	165	165	160
Power/Ratings												
Top burners (000's BTU's) Nat/LP	(1) 12.0/11.0 (1) 5.0/5.0 (2) 9.5/9.5	← (4) 9.5/9.5 →		← (4) 9.0/8.0 →								
Oven/broiler burners (000's BTU's) Nat/LP	← 18.0/16.5 →											
Gas range electrical rating**	← 120V, 60Hz., 5A →											
LP conversion kit (included)	•	•	•	•	•	•	•	•	•	•	•	•

*WW= White on white, AA = Almond on almond, WH = White, AD = Almond, CM = Color-Matched indicates color of oven door matches cooktop (either White or Almond).

**Electrical rating not applicable to standing pilot models.

†JGBS04BPA, JGBS04PPA and JGBS03PPA have standing pilot ignition.

Factory set for Natural Gas. A set of LP orifices is included with each XL44™ range for LP conversion.

Note: Model JGBS03PPA does not have a flamer spreader in broiler compartment.

Model	A	B	C*	D	E
JGBS23BEA/WEA/AEA	30	46-1/2	26-1/4	46-3/8	36 ± 1/4
JGBS22BEA	30	46-1/2	26-1/4	46-3/8	36 ± 1/4
JGBS21PEA	30	46-1/2	26-1/4	46-3/8	36 ± 1/4
JGBC20BEA	30	46-1/2	26-1/4	46-3/8	36 ± 1/4
JGBS20BEA	30	46-1/2	26-1/4	46-3/8	36 ± 1/4
JGBC20WEA	30	46-1/2	26-1/4	46-3/8	36 ± 1/4
JGBS20WEA	30	46-1/2	26-1/4	46-3/8	36 ± 1/4
JGBC17PEA	30	46-1/2	26-1/4	46-1/4	36 ± 1/4
JGBS17PEA	30	46-1/2	26-1/4	46-1/4	36 ± 1/4
JGBS15PEA	30	46-1/2	26-1/4	46-1/4	36 ± 1/4
JGBS07PEA	30	45-1/2	26-1/4	46-1/4	36 ± 1/4
JGBS04BEA/BPA	30	45-1/2	26-1/4	46-3/8	36 ± 1/4
JGBS04PEA/PPA	30	45-1/2	25-5/16	46-1/4	36 ± 1/4
JGBS03PPA	30	40	25-5/16	46-1/4	36 ± 1/4

*Dimension from wall to front of closed door handle is 29". On models JGBS04 and JGBS03 the dimension is 27-7/16".

25-1/4"—Depth to front top edge of cooktop

Installation Information (Dimensions in inches)

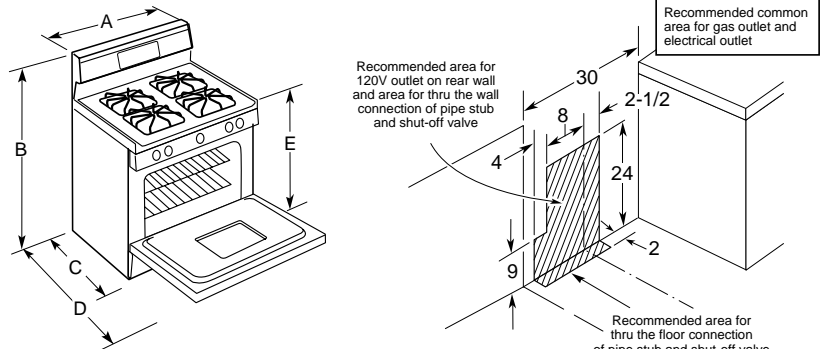

Warranty Information

Full one-year warranty (parts and labor at no additional charge) applies to the entire range. See written warranty for details.

TO RAISE OR REMOVE COOK TOP

- Remove 4 burner caps and 4 burner heads
- Remove 4 electrodes (pull up on the electrode while gently rotating at the same time) & disconnect electrode leads.
- Remove (12) T-15 torx screws which mount the orifice holders to the cook top
- Disengage the 2 front clips using a flat screw driver and gently raise the top high enough for the prop rods to hold it upright.

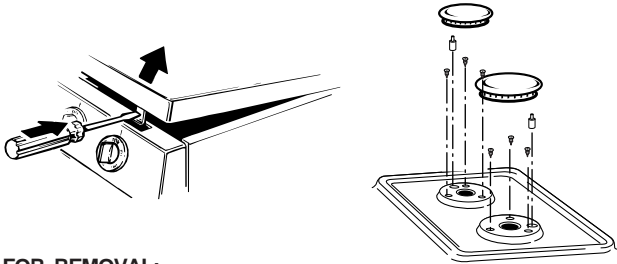

FOR REMOVAL:

- Disengage the prop rods from the range slide panels
- While raising the front of the cooktop, lower the rear of the cook top and shift the top left or right in order to disengage the hinge pins at the rear.

IMPORTANT COOK TOP REINSTALLATION NOTES:

Before lowering the top onto the front clips, feed the electrode leads through each opening in the cook top. Next be sure that the electrode clips are inserted into each of the orifice brackets (see illustration below). Line up the orifice brackets with the holes in the cook-top and start the screws, which secure the cook-top to the orifice holders. Before tightening the screws be sure to check the electrode leads to ensure that they do not get pinched between the cook top and the orifice holder. Reconnect the electrode wires and gently push each of the electrodes into position.

When reinstalling the top, position the top to be the equivalent of 1/2 way lowered, before attempting to insert the top hinge pins into the corresponding slots on the back-guard.

COOK TOP / SURFACE BURNERS

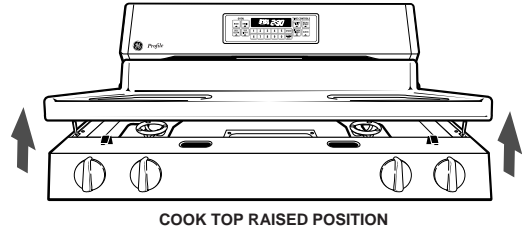

COOK TOP RAISED POSITION

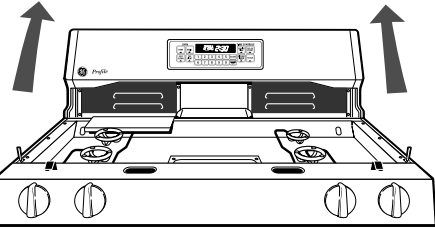
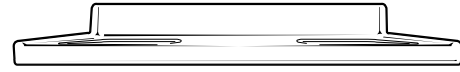

COOK TOP REMOVAL

BURNER HEAD

The burner head has a flame stability chamber which protects a small pocket of flame. This small pocket of flame provides quick reignition, in the event of a minor burner flame outage during simmer. It also provides an additional measure of safety.

The burner head also provides a positive target area for the ignitor.



BURNER HEAD

IGNITOR

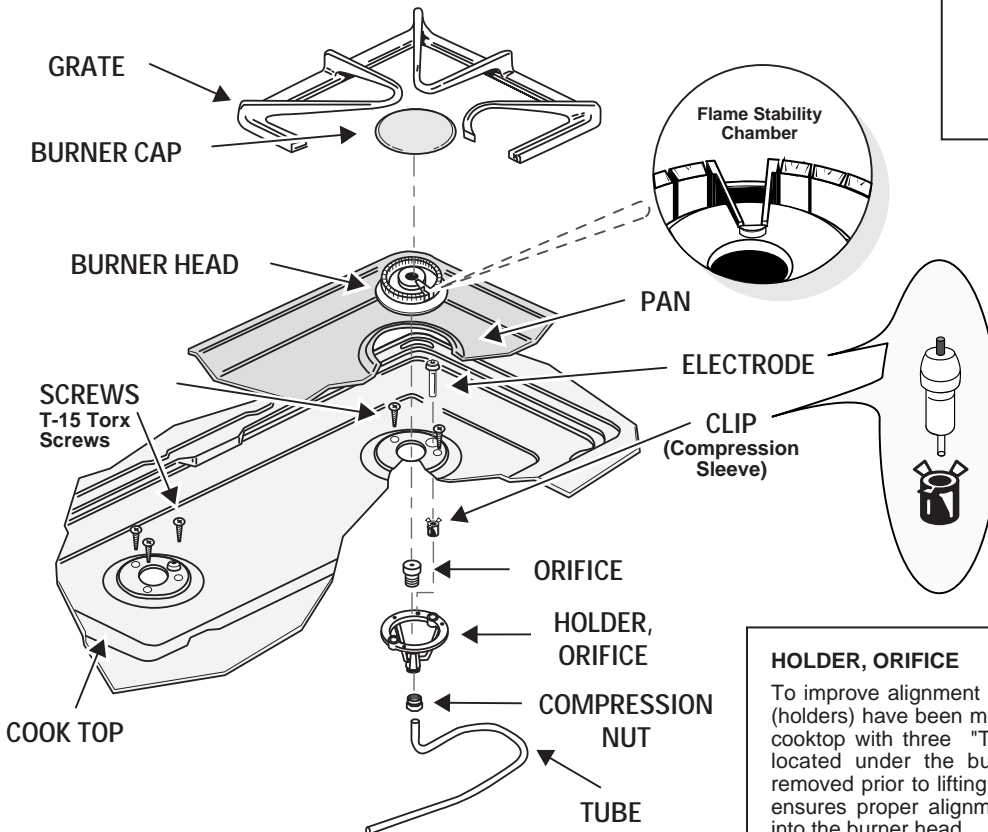

ELECTRODE MOUNTING

Each electrode pushes into a clip (compression sleeve), which mounts to each of the four orifice holders. This allows the electrode to be removed without lifting the top. To remove the electrode, grasp it with your finger and thumb and pull upward. A slight twisting action may help in removing the electrode. All four electrodes **MUST** be removed prior to lifting the top.

HOLDER, ORIFICE

To improve alignment and stability the 4 burner orifice brackets (holders) have been modified. The brackets are mounted to the cooktop with three "T-15" torx screws. The screw heads are located under the burner head. These screws **MUST** be removed prior to lifting the cooktop. The rigid mounting system ensures proper alignment of the orifice for gas to be injected into the burner head.

CONVERSION TO LP (PROPANE) GAS

- 1 Convert Regulator** - Regulator is located in the lower, left hand rear corner of the range as viewed from the front.

Depending on the model, remove the storage drawer, broiler drawer or false panel to access the regulator. Some models with a broiler drawer will have a metal cover over the regulator that must be removed for conversion and reinstalled when conversion is complete.

- 2 To Convert** - remove the large hex-nut which is located in the center of the regulator. Remove the plastic pin from the bottom side of the cap, turn the pin 180 degrees and snap the pin back into the cap. There are raised letters on the flat side of the plastic pin, "NAT" and "L.P.". In the "LP" position the end of the pin marked "NAT" should be snapped into the bottom of the hex-nut.

- 3** Remove surfaced burners and replace all 4 top burner orifices spuds with the L.P. orifice spuds supplied with the range (refer to the Technical Data Sheet supplied with the product for proper L.P. spud location and orifice color identification).

- 4** Using a 1/2" wrench, tighten the orifice hood(s) supplying gas to the oven burner(s) clockwise until snug.

Open the air shutter on the oven burner(s) to the full open position and adjust as needed.

- 5** Adjust the low flame (simmer) setting on the surface burners.

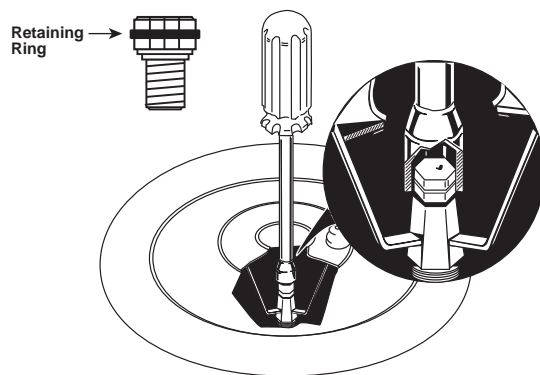
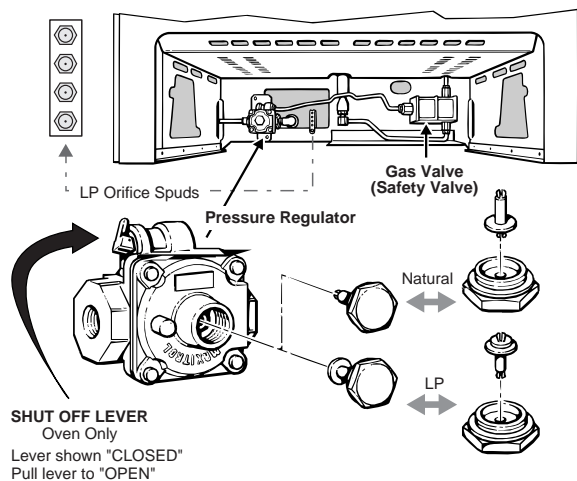

LOW FLAME (SIMMER) ADJUSTMENTS

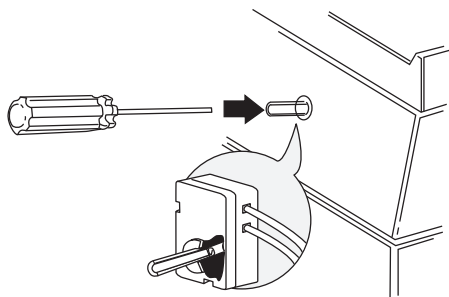

The top burner valves have low flame/simmer adjustment screws in the center of the control shafts. A flashlight may be required to locate the screw. A small thin blade screwdriver (approx. 3/32" blade width) is needed to access the screw.

TO ADJUST THE LOW FLAME SETTING - at least two other burners must be lit. Lite the burner being adjusted and turn the knob to "LOW". Remove the knob and insert the screwdriver into the shaft of the control valve. Turn the adjustment screw to reach the desired flame size.

TEST FLAME STABILITY - by quickly turning the knob from "HI" to "LOW". If the flame goes out, increase the flame size and test again. Also test flame stability by quickly opening and closing the oven door. If the flame is extinguished by the air current created by the door movement, increase the flame size.

The top burner orifices can be removed by removing the burner cap and burner heads. Using a 7 millimeter (mm) or a 9/32" nut-driver carefully slide the driver down over the orifice and rotate counterclockwise to remove.

IMPORTANT NOTE: the orifices have a spring loaded retaining ring around the hex head to hold the orifice in the nut driver during installation and removal. A slight amount of force is required to push the nut driver down over the ring.

TOP BURNER FLAME ADJUSTMENTS

The top burners do not have air shutters adjustments and use non-adjustable orifices. If the flame lifts off of the burner, or if you experience "Yellow Tip" flames and/or soot in the flames, be sure to check the following:

- Gas pressure: 4" W.C.P. (natural) and 10" W.C.P. (L.P.)
- Inspect orifice to be sure it is drilled in the center and free of debris or burrs.
- Be sure the correct size orifice is in the proper location
- Make sure the range was properly converted if on L.P.
- If the cause of sooting can not be found in the above checks, replace the orifice with one having a smaller diameter opening

IMPROPER FLAME

Yellow Tips, Soot and/or Flame Lifting off Burner

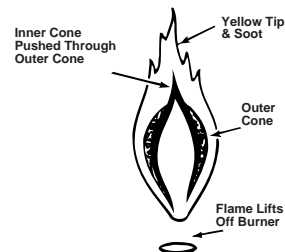

CONVERSION & ORIFICES INFORMATION

BAKE BURNER ADJUSTMENTS

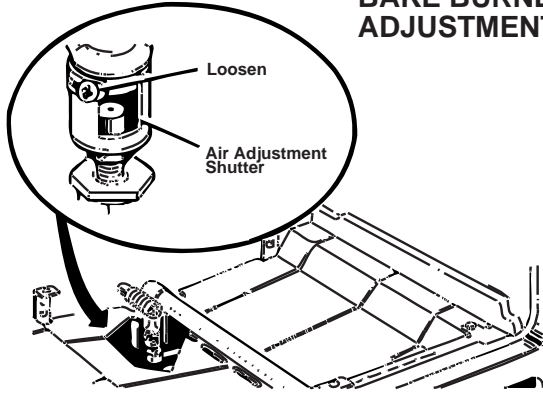

BROIL BURNER ADJUSTMENTS

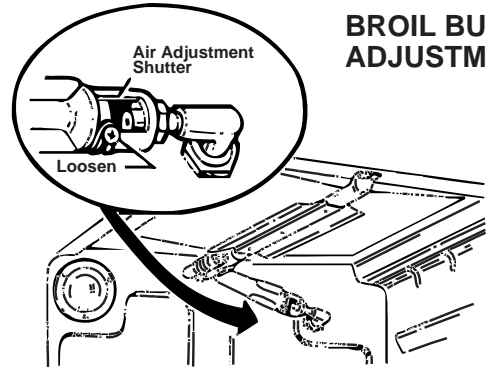

6 Open the bake and broil air shutter adjustments as far as possible and adjust later if necessary.

Beneath the bake and broil burner orifice hoods are LP orifice needles. To convert to L.P. tighten the orifice hoods against the orifice needle until the hoods are snug (2-2½ turns). **DO NOT OVER TIGHTEN.** Check the burners for proper flame adjustment. The burner flame should have approximately 1" blue cones. With most LP gas, small yellow tips at the end of outer cones are normal. flames should not lift off burner ports. If lifting is observed, gradually reduce the air shutter opening until flames are stabilized.

ORIFICE INFORMATION

JGBP85BEA Orifice Charts

BURNER OUTPUT RATINGS; BTU/HR		
NATURAL GAS with 4" W.C.P.		
Burner	BTU Rate	Orifice Size
LF, RF	12,000	1.68 mm (III)
LR	9,500	1.50 mm (II)
RR	5,000	1.07 mm (I)
BAKE	16,000	#47 (.0785")
BROIL	13,500	.069"

Natural gas surface orifices are marked on top as shown

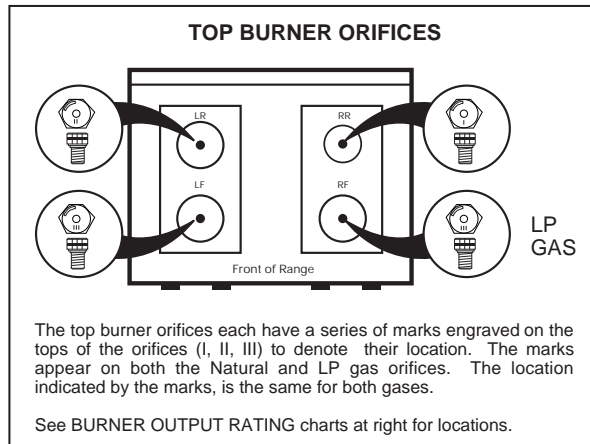

BURNER OUTPUT RATINGS; BTU/HR		
LP (PROPANE) GAS with 10" W.C.P.		
Burner	BTU Rate	Orifice Size
LF, RF	11,000	.94L mm (III)
LR	9,500	.89L mm (II)
RR	5,000	.63L MM (I)
BAKE	16,000	#56 (.0465")
BROIL	12,000	#59 (.041")

LP gas surface orifices are marked on top as shown

SMALLER ORIFICES FOR HIGHER ELEVATIONS				
Burner	Size	Part Number	L.P.	Natural
LF & RF	1.65 mm	WB02X9841		✓
LF & RF	.84 mm	WB02K0022	✓	
LR	1.44 mm	WB06K0094		✓
LR	.73 mm	WB19K5000	✓	

LP ORIFICE COLOR ID		
Burner	BTU Rate	Color
LF & RF	11,000 BTU	Blue / Magenta
LR	9,500 BTU	Blue / Brown
RR	5,000 BTU	Blue / Blue

Paint color codes have been added to the sides of the LP orifices to aid in identifying the proper orifice location during conversion.

IMPORTANT NOTE: Always consult the Technical Service literature (mini-manual) enclosed with the appliance for model specific conversion information

CONTROL PANEL ACCESS

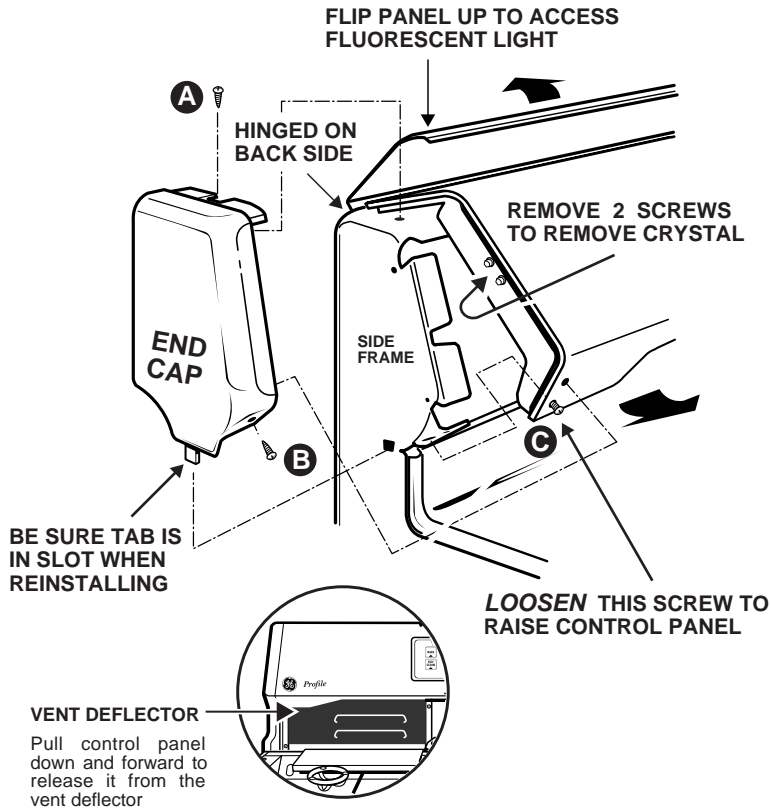

TO REMOVE CONTROL PANEL

1. Grasp the light panel cover at the rear, where it is hinged to the control panel. Lift upward at the rear, just far enough to insert a small, thin bladed screw driver between the end cap and the fluorescent light cover. Slide the blade forward toward the front while lifting upward on the cover. Be sure to wrap the blade of the screw driver with tape so as not to scar the plastic shield.
2. Remove screws **A** & **B** which secure the endcaps to the control console. Be careful when removing the endcap not to break the locating tab at the bottom of the endcap.
3. LOOSEN screw **C**. DO NOT REMOVE. This screw is just long enough that it will protrude into a slot in the side frame, causing the panel to bind as you slide it down and forward. Loosening the screw a couple of turns will back it off enough that it will no longer protrude into the side frame slot.
4. Grasp the face panel at the bottom front with one hand, while gently pushing down on the top of the control panel with your other. Pull panel downward to release it from the vent deflector while at the same time pull the

REINSTALLING CONTROL PANEL

When reinstalling the control panel, push up on the vent lip with your fingers. At the same time pull forward on the control panel, making sure that the vent lip is **TUCKED UNDER** the control panel while lowering the panel into place.

SPARK MODULE

The spark module is located behind the control panel, on the right side. You must remove the control panel to access the spark slot.

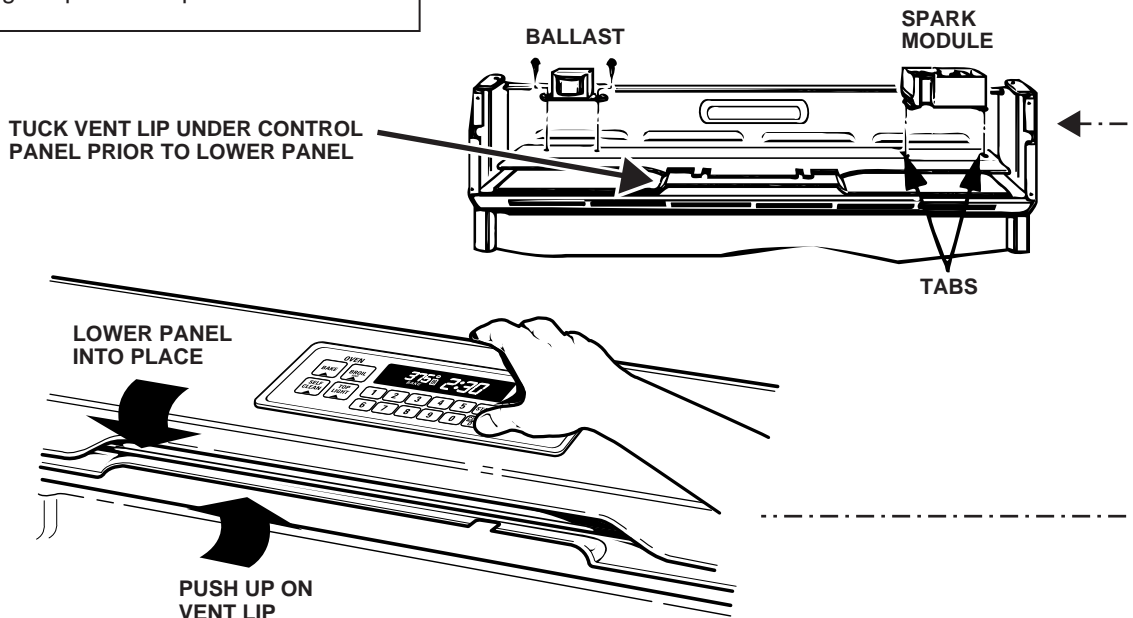

ERC III SPECIAL FEATURES

The "SPECIAL FEATURE" modes can only be activated while the display is showing the time of day clock. These special features remain in the ERC's memory until you or the consumer change them. When the display shows your choice press the START pad. The special feature you selected will remain in memory even after a power failure.

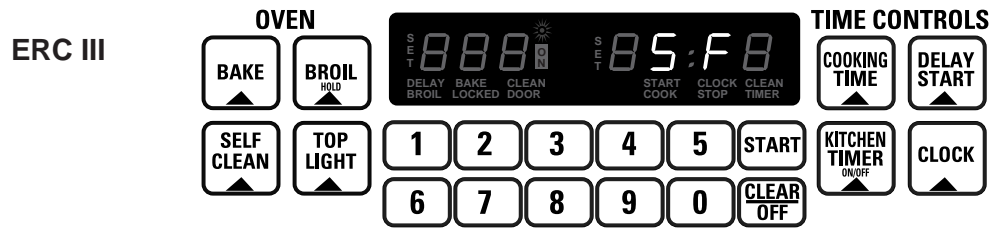

TO ADJUST THE THERMOSTAT (MODELS WITH NUMBER PADS)

- Press the BAKE and BROIL HI/LO pads at the same time for 2 seconds until the display shows "SF".
- Press the BAKE pad. A two digit number shows in the display. Press the BAKE pad once to increase (+) the oven temp. or twice to decrease (-).
- The oven temp. can be adjusted up to (+) 35°F. hotter or (-) 35°F. cooler. Press the number pads the same way you read them. For example, to change the over temperature 15°F., press 1 and 5.
- When you have made the adjustment, press the START pad to go back to the time of day display.

NOTE: Adjustments will not affect the broiling or self-cleaning temperatures. It will be retained in memory after a power failure.

12 HOUR SHUT-OFF

With this feature, should you forget and leave the oven on, the control will automatically turn off the oven after 12 hours, during baking functions, or after 3 hours during a broil function. If you wish to turn off this feature, follow the steps below:

- Press the BAKE and BROIL HI/LO pads at the same time for 2 seconds until the display shows "SF".
- Press the DELAY START or START TIME pad. The display will show "12 Shdn" (12 hour shut-off). Press the DELAY START or START TIME pad again and the display will show "no Shdn" (no shut-off).
- Press the START pad to activate the no shut-off and leave the control set in this special features mode.

CONTROL LOCKOUT (CHILD LOCKOUT)

The ERC control will allow you to lock down the touch pads so they cannot be activated when pressed.

- Press the BAKE and BROIL HI/LO pads at the same time for 2 seconds until the display shows "SF".
- Press the SELF CLEAN pad. The display will show "Loc OFF." If this is your choice, press START.
- Press the SELF CLEAN pad again. The display will show "Loc On." If this is your choice, press START.

When this feature is on and the touch pads are pressed the control will beep and the display will show "LOC."

NOTE: The control lockout mode will not affect the clock, timer and oven light touch pads

12 HOUR, 24 HOUR OR CLOCK BLACK-OUT

The ERC control is set to use a 12 hour clock. If the customer prefers to have a 24 hour military time clock or black-out the clock display, follow the steps below.

- Press the BAKE and BROIL HI/LO pads at the same time for 2 seconds until the display shows "SF".
- Press the CLOCK pad once. The display will show "12 hr."
- Press the CLOCK pad again to change to the 24 hour military time clock. The display will show "24 hr." If this is your choice, press START.
- Press the CLOCK pad again to black-out the clock display. The display will show "OFF." If this is your choice, press START.

If the clock is in the black-out mode and you want to restore it to the display, repeat steps 1 and 2.

NOTE: If the clock is in the black-out mode you will not be able to use the DELAY START function.

COOK AND HOLD

The cook and hold feature keeps cooked foods warm for up to 3 hours after the cooking function is finished. To activate this feature, follow the steps below:



Press the BAKE and BROIL HI/LO pads at the same time for 2 seconds until the display shows "SF".



Press the COOKING TIME pad. The display will show "HLd OFF." Press the COOKING TIME pad again to activate the feature. The display will show "HLd On."



Press the START pad to activate the cook and hold feature and leave the control set in this special features mode.

CHANGING THE SPEED OF THE (+) OR (-) PADS (ON SOME MODELS)

As you use the + or - pads when setting a time or temperature, you may notice the display changes slowly. This special feature allows you to change the speed by performing the following steps:



Press the BAKE and BROIL HI/LO pads at the same time for 2 seconds until the display shows "SF".



Press the (+) pad. The display will show you a set speed between 1 and 5.



Press the (+) pad to increase the speed up to the number 5.

Press the (-) pad to decrease the speed down to the number 1.



Press START to activate the setting and leave the control set in this special features mode.

TONES AT THE END OF A TIMED CYCLE

At the end of a timed cycle, 3 short beeps will sound followed by one beep every 6 seconds, until the CLEAR/OFF pad is pressed. This continuous 6 second beep may be canceled.

To cancel the 6 second beep:



Press the BAKE and BROIL HI/LO pads at the same time for 2 seconds until the display shows "SF".



Press the KITCHEN TIMER ON/OFF pad. The display shows "Con bEEP" (continuous beep). Press the KITCHEN TIMER ON/OFF pad again. The display shows "bEEP." This cancels the one beep every 6 seconds.



Press the START pad.

FAHRENHEIT OR CENTIGRADE TEMPERATURE

The ERC control is set to use the Fahrenheit temperature selections, but you may change this to use the Centigrade selections.



Press the BAKE and BROIL HI/LO pads at the same time for 2 seconds until the display shows "SF".



Press the BROIL HI/LO pad. The display will show "F" (Fahrenheit). If this is your choice, press START.



Press the BROIL HI/LO pad again. The display will show "C" (Centigrade). If this is your choice, press START.

HELPFUL USE AND CARE INFORMATION

CLOCK - The clock must be set before the control for the oven will work. the time of day clock cannot be changed during DELAY START. It can be changed during a regular bake or broil operation.

KITCHEN TIMER - Does not control oven operation. You may program the timer for activities up to 9 hours and 59 minutes. When the timer reaches " :00," the control will beep 3 times followed by one beep every 6 seconds until the KITCHEN TIMER ON/OFF pad is pressed. To cancel the timer, press and hold the KITCHEN TIMER ON/OFF until the word "TIMER" disappears from the display.

POWER FAILURE - If a flashing time is in the display, you have experienced a power failure. Reset the clock.

PREHEAT NOTIFICATION TONE - When you set an oven temperature the oven automatically starts to heat. When the temperature inside the oven reaches your set temperature a tone will sound to let you know to place the food in the oven.

LIGHTING SURFACE BURNERS - When one burner is turned to the LITE position, all the burners will spark. The igniter switches now come as one assembly, each one wired in parallel to the other.

BROILING - The oven door must be closed during broiling operation.

SELF CLEANING - We recommend venting with an open window or using a ventilation fan or hood during the first self-clean cycle.

Do not use commercial oven cleaners or oven protectors in or near the self-cleaning oven. A combination of any of these products plus the high clean cycle temperatures may damage the porcelain finish of the oven.

The oven front frame and the oven door outside the gasket do not get cleaned by the self-clean cycle. On these areas use detergent and hot water or a soap-filled steel wool pad. Rinse well with a vinegar and water solution. This will help prevent a brown residue from forming when the oven is heated. Buff these areas with a dry cloth. Do not clean the gasket.

E
xceptional cooking

performance does not come about by chance. It requires advanced technology and innovative design. GE proudly introduces the TrueTemp™ System, which delivers consistently even oven temperature for exceptional cooking results -- making it the industry leader.

The Most Accurate Oven In America!*

SmartLogic™ Electronic Control with Platinum Oven Sensor Monitors and maintains oven temperature. Senses sudden, significant heat loss and responds with extra power.

* Among leading brands

TrueTemp™

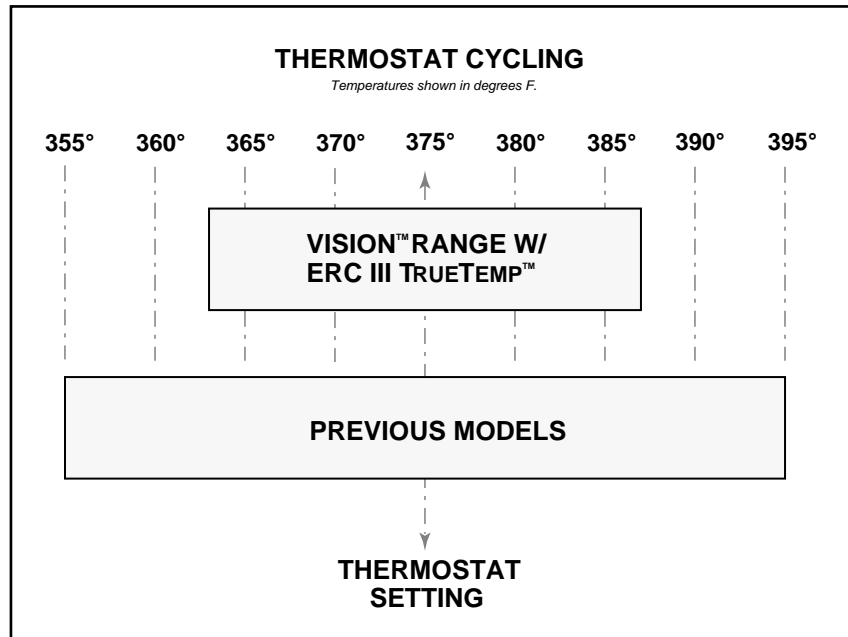

GE TRUETEMP™, THE MOST ACCURATE OVEN IN AMERICA!

The guesswork is gone. The temperamental oven is a thing of the past. GE's exclusive TrueTemp™ system manages and maintains the oven temperature you select. It's more accurate than any other leading brand. The SmartLogic™ electronic control, with a platinum sensor, constantly monitors the oven's performance to ensure more precise temperature management. Even if you open the door when the oven is on, SmartLogic™ senses variations in temperature and responds to regain the selected setting.

* Among leading manufactures' brands

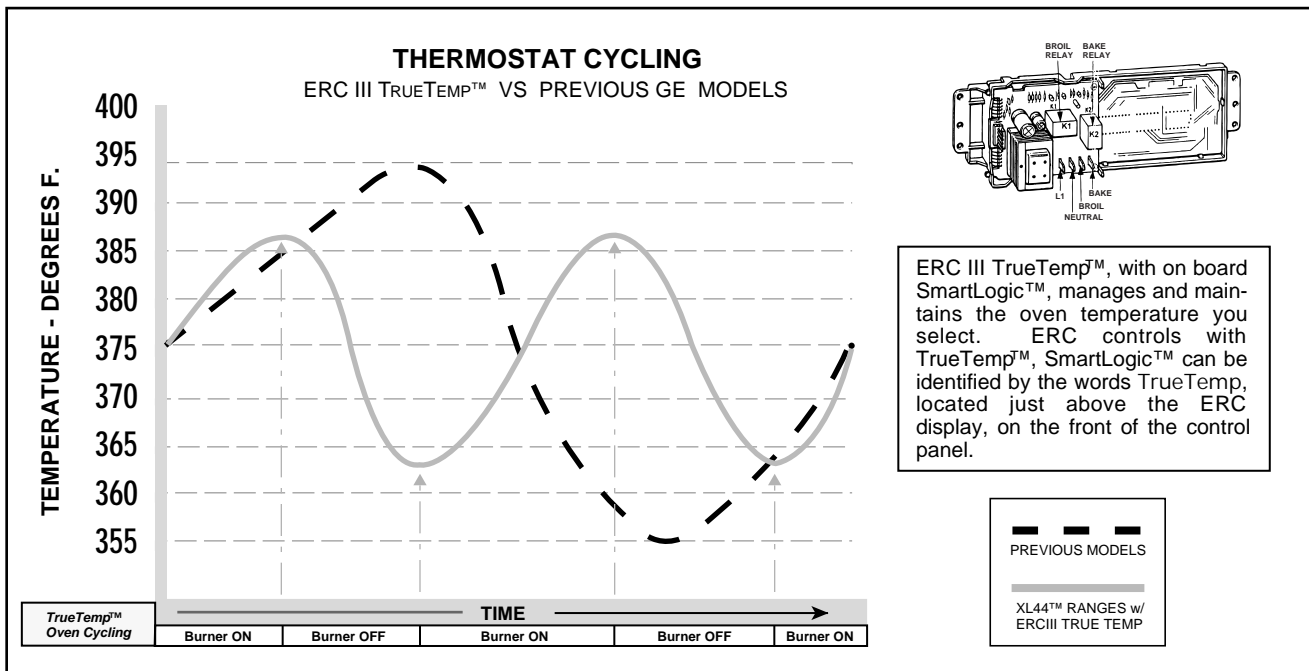

ERC FAULT CODE MEMORY DISPLAY

Have you ever run a service call and been told by the consumer that their range displayed an "F" fault code and when you arrive the fault is gone (cleared by the consumer) and the consumer can not remember what the code was?

Well there is now a way to "recall" the last four fault codes from the ERC memory. Care must be taken in interpreting these codes because once you determine the cause of the fault code, there is no way to clear the code(s) from the ERC memory. In other words, the history that you are looking at in the display could be a weeks worth of history, or 5 years - there is no way to tell. With this in mind, the last fault code stored in memory is the one that you should focus on, because the others may have occurred a long time prior to the last one.

HOW TO DISPLAY THE FAULT CODES IN MEMORY

To read the fault code memory, follow the steps below:

1. Simultaneously press the COOKING TIME, DELAY START and number 9 pads. A history of the last four fault codes will appear in the display. NOTE: If no keypad entry is made within 5 minutes, the ERC test mode will "time out".
2. To terminate the memory fault mode press the CLEAR / OFF key pad

HOW FAULT CODES ARE STORED IN MEMORY - EXAMPLE

A If we displayed the fault code memory for a new range, one that has never experienced a fault code, we would see four zero's in the display, meaning that no fault codes are stored in memory.

B The first time a fault code occurs, the ERC display will **store** the fault code in it's memory. When you read the fault code which is stored in memory, the code will display in the far right hand digit of the clock display.

C If a second fault code occurs, it too is stored in the ERC memory. The first fault code stored in memory scrolls to the left, and the new fault code now displays in the far right hand digit of the clock display.

D If the same fault code repeats itself (sequentially), without being separated by a different fault code, then the repeated fault code will **"stack"** in memory. In other words, the repeated fault code will **only** display once, unless separated by a different fault code. In this example, F3 repeats itself twice, the resulting fault code memory display only shows one 3. The same would also be true if F3 repeated itself four times, the result showing in the fault code memory display would be one "3", NOT four "3"s.

E If a fourth fault code occurs, the ERC will scroll the previous fault codes stored in memory to the left, one digit, and store the new fault code in the far right hand digit of the clock display.

F If a fifth fault code occurs, the ERC will continue to scroll the previous fault codes to the left, and store the new fault code in the far right hand digit of the clock display.

G If a sixth fault code occurs, the ERC will once again scroll the previous fault codes to the left. Notice in this example the first fault code (F1), previously stored in memory is now lost. The ERC will continue to scroll the previous fault codes to the left and store the new fault code in the far right hand digit of the clock display.

ERC FAULT CODE MEMORY TEST

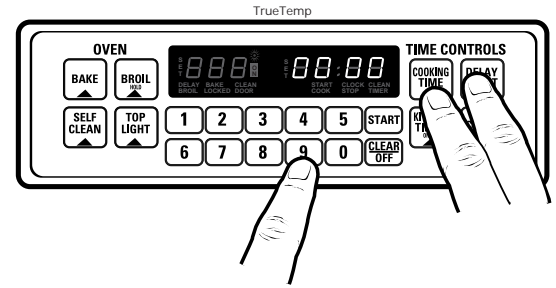

No Fault codes new range



First fault code - F1



Second fault code - F3 (scrolls left)



Third fault code - F3 (stacks)



Fourth fault code - F1 (scrolls left)



Fifth fault code - F4 (scrolls left)



Sixth fault code - FF (scrolls left)

ERC DIAGNOSTIC TESTS

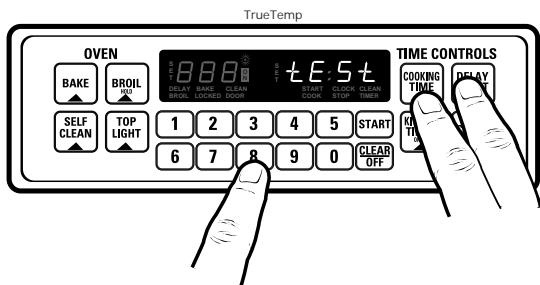

ERC ON BOARD DIAGNOSTIC TESTS

This test allows the Technician to energize the bake and broil relays (listen for A click), use the ovens onboard temperature sensing and control system to measure oven temperature (sensor, connector and ERC diagnosis) and lastly it allows you to test keypad input responses.

HOW TO ENTER AND EXIT THE DIAGNOSTIC MODE

To perform the ERC diagnostic tests, follow the steps below:

1. To initiate the ERC test mode, first remove power to the appliance for approx. 8 seconds and then reapply power.
2. Simultaneously press the COOKING TIME, DELAY START and number 8 pads. The word "tEst" will appear in the ERC display. NOTE: If no keypad entry is made within 5 minutes, the ERC test mode will "time out".
3. To terminate the ERC test mode, press the CLEAR / OFF key pad.

HOW TO PERFORM THE TESTS

The following tests allow you to quickly verify various ERC and keypad functions. Listed below are four common diagnostic tests that can be made directly from the ERC.

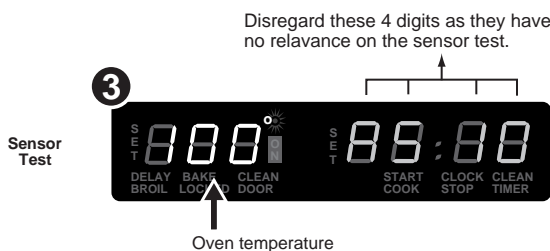

1 ENERGIZE BAKE CIRCUIT - To perform this test, press BAKE then START and listen for the bake relay to energize. CAUTION: If you hold the start pad in, you are energizing the BAKE circuit. As soon as you release the START pad the relay will deenergize. If the relay does not energize, check the following: reconfirm that you have entered the test mode correctly, check power and wiring connections to the ERC, and lastly suspect a faulty ERC. NOTE: when performing this test, the glowbar will be energized as long as you hold in the start pad.

2 ENERGIZE BROIL RELAY - To perform this test, press BROIL then START and listen for the broil relay to energize. CAUTION: If you hold the start pad in, you are energizing the BROIL circuit. As soon as you release the START pad the relay will deenergize. If the broil relay does not energize, check the following: reconfirm that you have entered the test mode correctly, check power and wiring connections to the ERC, and lastly suspect a faulty ERC. NOTE: when performing this test, the glowbar will be energized as long as you hold in the start pad.

3 SENSOR TEST - To perform this test, press and hold the COOKING TIME pad or DELAY START pad (vaies by model). The oven temperature will show in the display. NOTE: oven temperatures below 100°F. will show as 100°F. If the temperature showing in the display is not correct then suspect the following: calibration, sensor, sensor connection, or ERC.

4 NUMERIC KEY PADS TEST - To perform proper numeric key panel input responses, press any numbered key pad and hold it in for approximately 5 seconds; the number you are pressing will show in the ERC display. If it does not, reconfirm that you have entered the test mode correctly, check wiring connections to the ERC and keypad, and lastly confirm shorted or open key pad by performing the Key Panel test on page 10.

LOCK MOTOR CIRCUIT

5 LOCK MOTOR CYCLE TEST - The lock motor cycle test allows you to run the latch assembly through one complete cycle of operation, testing motor operation and front & rear latch switch contacts. To perform this test, push and hold the SELF CLEAN key pad - make sure that the oven door is closed (light switch depressed). While depressing the SELF CLEAN pad the lock motor will run through a complete cycle. Watch the ERC display closely as it will change, based on the location of the motor and the position (open or closed) of the latch switches.

Illustrations A, B, C, and D show the sequence of events that will occur during the complete lock motor cycle, as well as what will be seen in the ERC display. Notice that the numbers shown in the left side of the display represent the position of the lock motor as well as the contact positions (open or closed) of the latch switches.

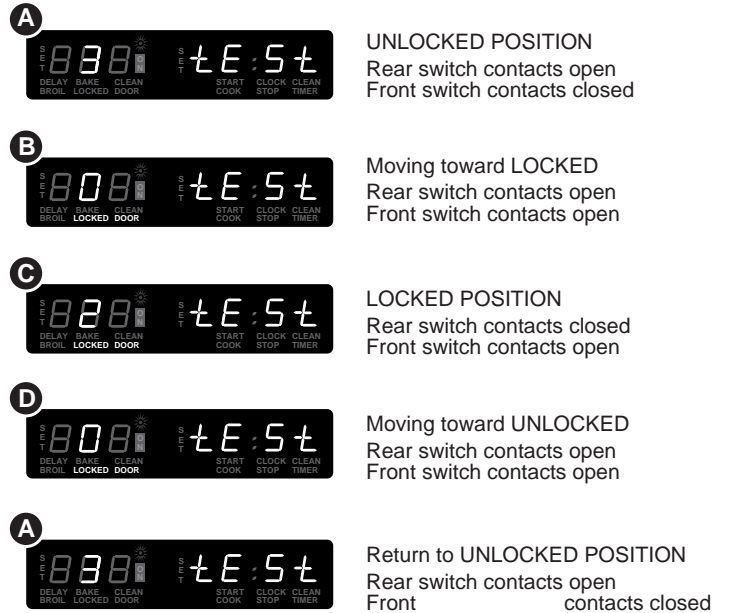

DOOR LATCH MECHANISM

The latch mechanism is thermally Controlled. When the SELF CLEAN cycle is selected and the oven sensor senses a temperature between 560°F and 650°F, the ERC supplies power to the lock motor, driving the motor towards the LOCKED position. When the lock motor reaches the LOCKED position, the micro-switches on the lock mechanism signal the control board to stop the motor, leaving it in the LOCKED position.

When the oven sensor senses a temperature of approximately 300°F, the control board once again supplies power to the lock motor, driving it towards the UNLOCKED position. When the UNLOCKED position is reached, the micro-switches on the lock mechanism signal the control board to stop the motor, leaving it in the UNLOCKED position.

LOCK MOTOR ACCESS

Remove the cooktop following the steps outlined on page 5 of this service guide - TO RAISE OR REMOVE COOKTOP.

Next remove the lock motor cover to gain access to the lock motor assembly.

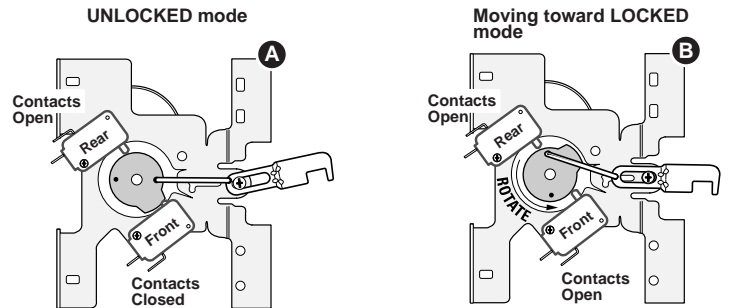
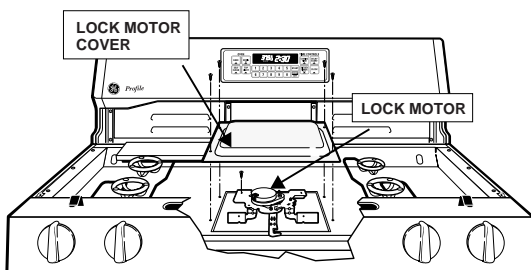

LOCK MOTOR CYCLE

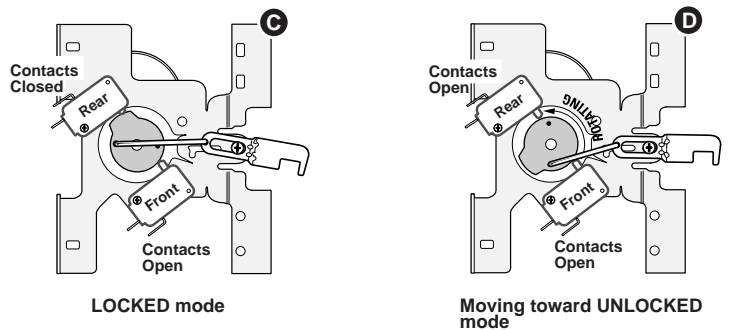

Latch circuit shown in UNLOCKED mode

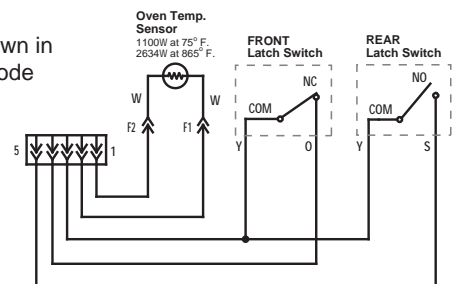

JGBP85BEA SCHEMATIC

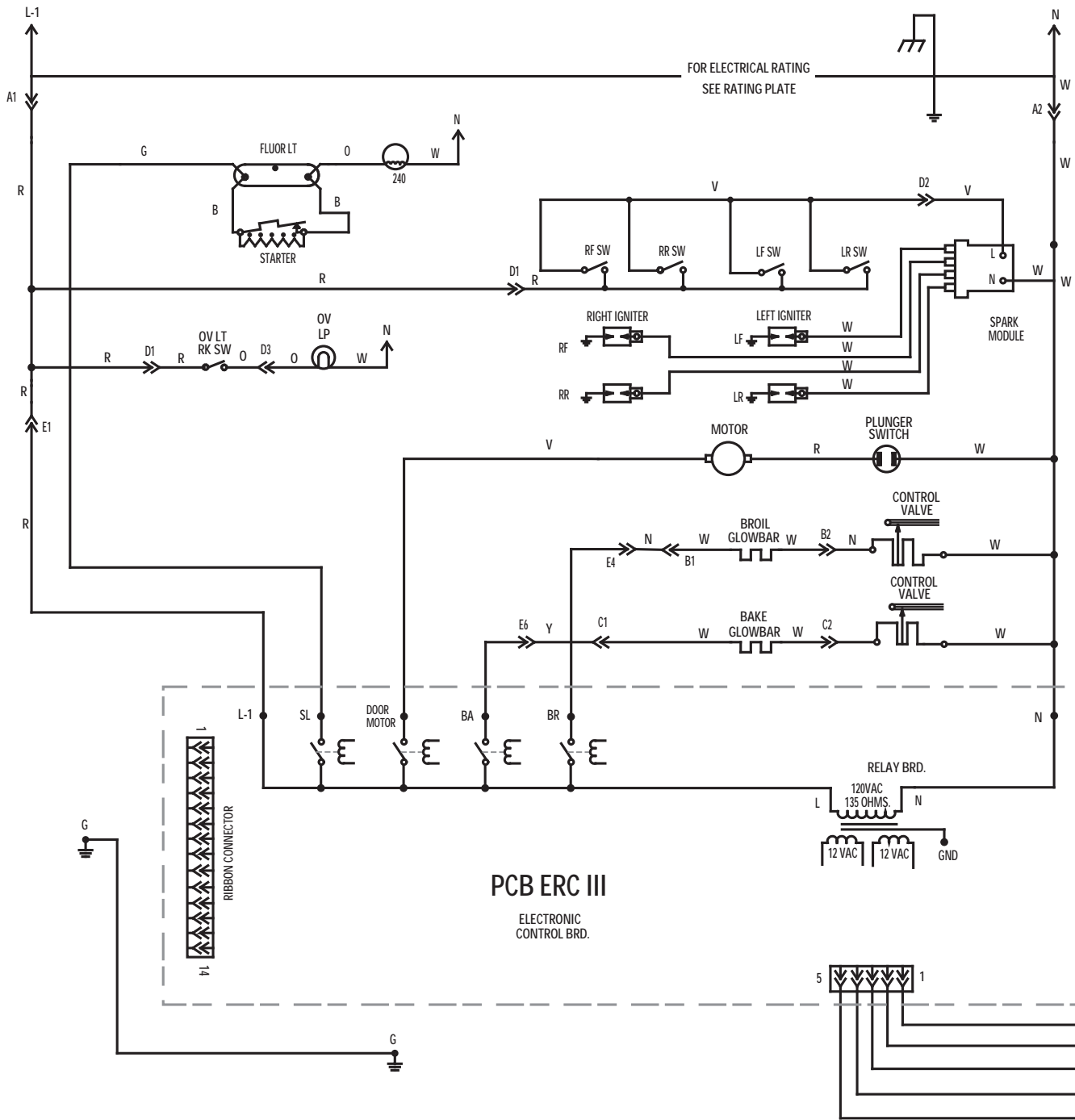

COLOR	SYMBOL
RED	R
WHITE	W
ORANGE	O
GREEN	G
YELLOW	Y
VIOLET	V
BLUE	N
GRAY	S

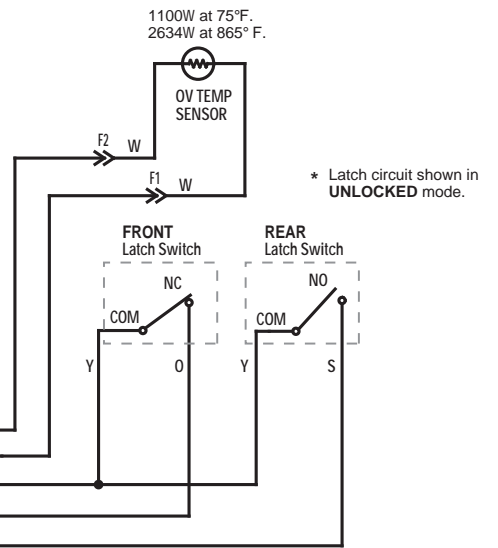
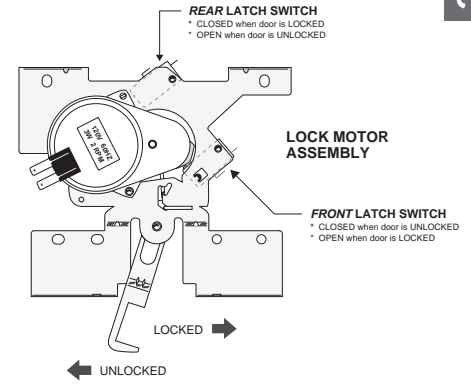

JGBP85BEA STRIP CIRCUITS

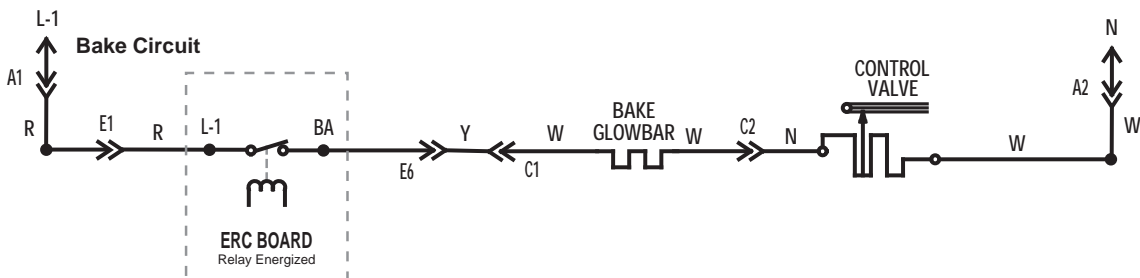
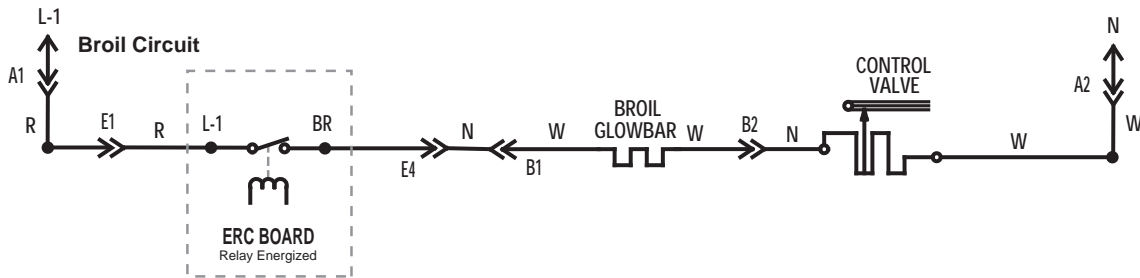
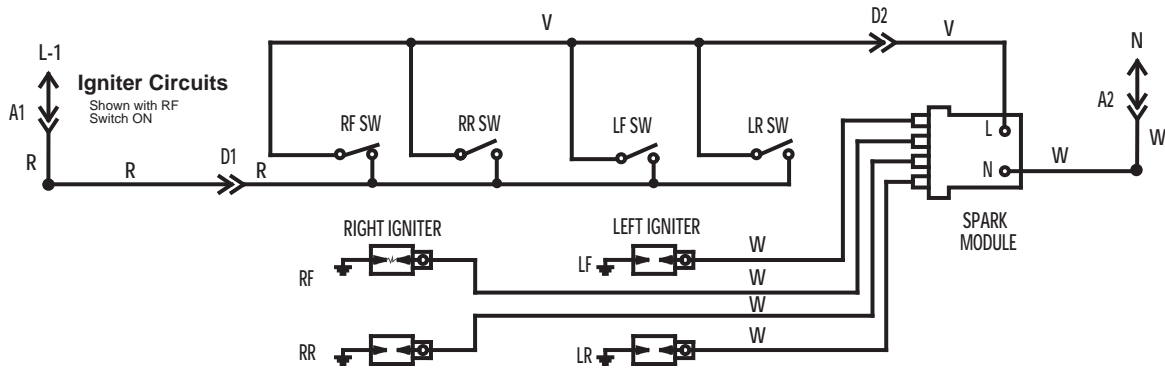
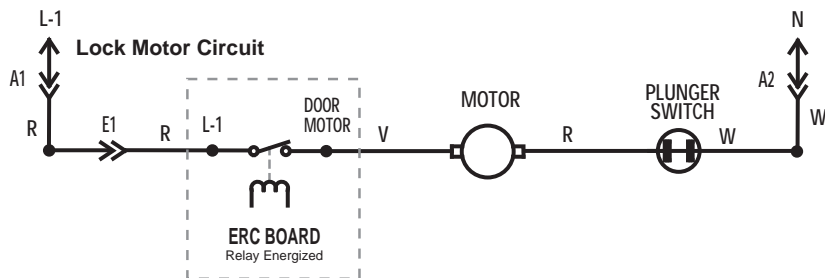
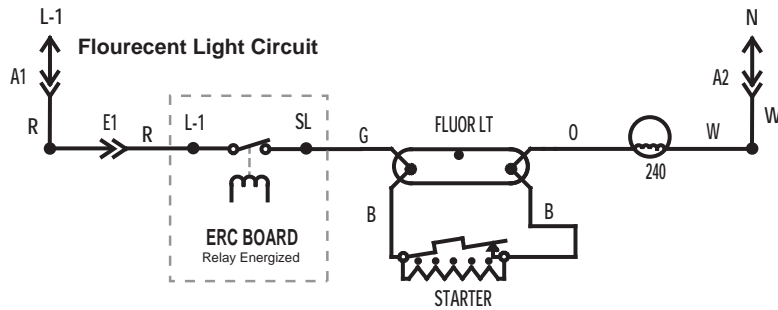
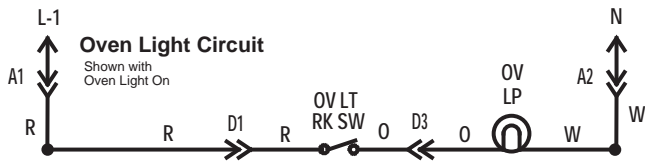

RELAY CONTACT OPERATION TEST			
Relay	Terminals	Voltage in Mode	Voltage in Off
Bake	BA to N	120 VAC in Bake	0 VAC in Off
Broil	BR to N	120 VAC in Broil	0 VAC in Off
Latch	Door Motor to N	120 VAC	0 VAC in Off
Surface Light	SL to N	120 VAC	0 VAC

COLOR	SYMBOL
RED	R
WHITE	W
ORANGE	O
GREEN	G
YELLOW	Y
VIOLET	V
BLUE	N
GRAY	S

JGBP85BEA DIAGNOSTIC INFO

IMPORTANT NOTE: While the information listed on this page is specific to one model, it reflects the type of information available on most mini-manuals enclosed with each product. **Always consult the mini-manual for model specific information.**



ERC III WITH TRUE TEMP™ AND SMARTLOGIC™

ERC RELAY CONTACT OPERATION TEST

Relay / Mode	Terminals	Voltage in Mode	Voltage in Off
Bake	BA to N	120 VAC in Bake	0 VAC in Off
Broil	BR to N	120 VAC in Broil	0 VAC in Off
Door Motor	Door Motor to N	120 VAC	0 VAC in Off
Surface Light	SL to N	120 VAC	0 VAC

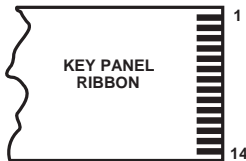

NOTE: Resistance values may vary from 20 to 90 ohms. An "OPEN" circuit would indicate a defect in the touch pad.

KEY PANEL TESTS

FUNCTION	TEST POINTS
Bake	11 to 13
Broil	10 to 13
Self Clean	8 to 13
Top Light	8 to 12
1	9 to 14
2	8 to 14
3	5 to 13
6	6 to 12
7	7 to 14
8	7 to 12
Cooking Time	10 to 12
Delay Start	11 to 12
Kitchen Timer	9 to 13
Clock	9 to 12
4	5 to 12
5	6 to 13
Start	1 to 2
Clear	3 to 4
9	7 to 13
10	10 to 14

FAILURE CODES - "F" CODES

Failure Code	Meaning	Suspect / Check
FFF	Control error, failed EEPROM	ERC
F0	Shorted CLEAR/OFF key	Membrane switch ERC
F7	Any shorted membrane key other than CLEAR/OFF	Membrane switch ERC
F2 During BAKE	Control senses oven temp. above 615 deg. F.	High resistance connection in sensor circuit ERC (welded bake relay contacts)
F2 During CLEAN	Control senses oven temp. above 915 deg. F.	High resistance connection in sensor circuit ERC (welded clean relay contacts) Both Lock switch 1 & 2 closed at the same time
F3	Open sensor; sensor resistance exceeds 2900 ohms during bake broil or clean	Sensor / sensor circuit connections
F4	Shorted sensor; sensor resistance is less than 2900 ohms during bake broil or clean	Sensor / sensor circuit connections
FF	Door motor safety circuit	ERC

ERC III SPECIAL FUNCTIONS (SF) MODE

Enter Special Functions mode by holding BAKE and BROIL pads for 2 seconds, until "SF" shows in display

KEY PAD	CONTROLS:	ERC DISPLAY WILL SHOW:
KITCHEN TIMER	End Of Cycle beep selection of continuous or non-continuous tones	bBEEP <-> Con bBEEP
BROIL	Degree switching from Centigrade to Fahrenheit	°F <-> °C
CLOCK	Time display mode 12 / 24 / Blank	12 hr -> 24 hr -> OFF -> 12 hr
COOKING TIME	Cook & Hold feature to maintain food at 170°F when timed cooking function ends. Enable / disable function	HLd On <-> HLd Off
SELF CLEAN	Child Lockout disables heating mode keys and displays "LOC" when key depressed	Loc On <-> Loc OFF
DELAY START	12 hr Shut Down Override enables / disables 12 hour safety shutdown feature	12 Shdn <-> no Shdn
BAKE	User Temperature Offset for oven temperature calibration	
CLOCK and KITCHEN TIMER	Sales Mode	Display will scroll the following: Display off BAKE icon on Temp digits 350 On icon and BAKE icon on Pause 2 seconds Display off BROIL icon on Temp digits on LO ON icon & broil element icon on Pause 2 seconds Temp digit on HI and broil element icon Pause 2 seconds

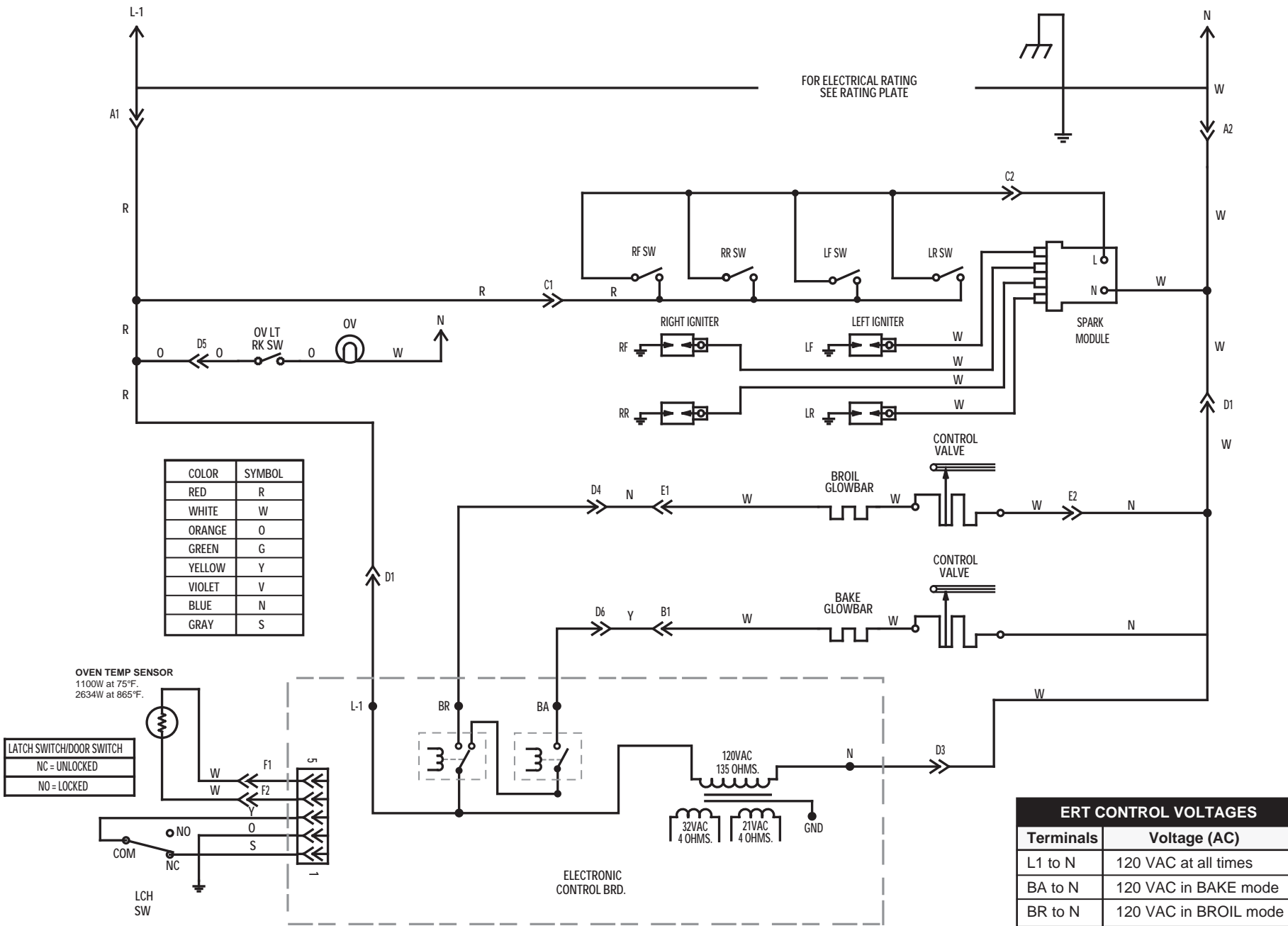

JGBP30BEA STRIP CIRCUITS

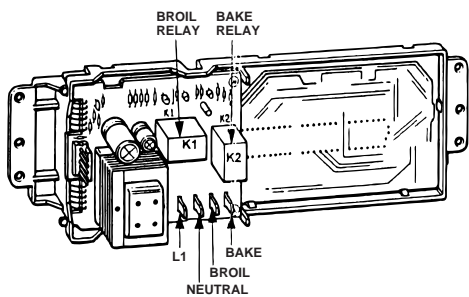

COLOR	SYMBOL
RED	R
WHITE	W
ORANGE	O
GREEN	G
YELLOW	Y
VIOLET	V
BLUE	N
GRAY	S

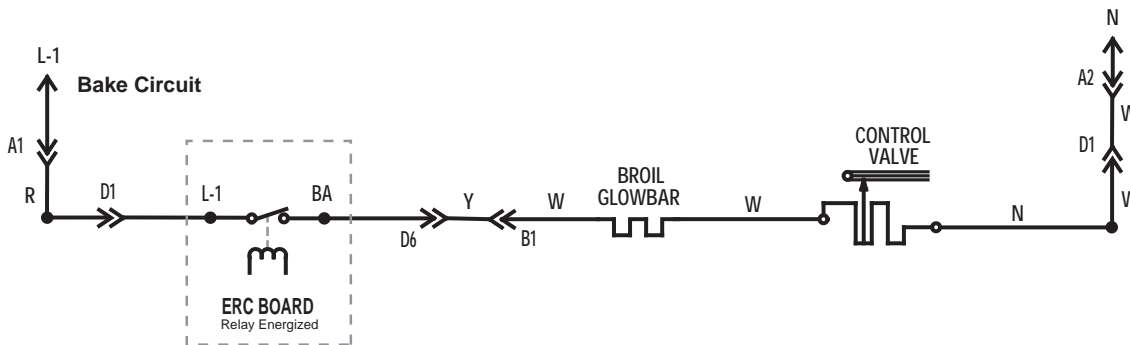
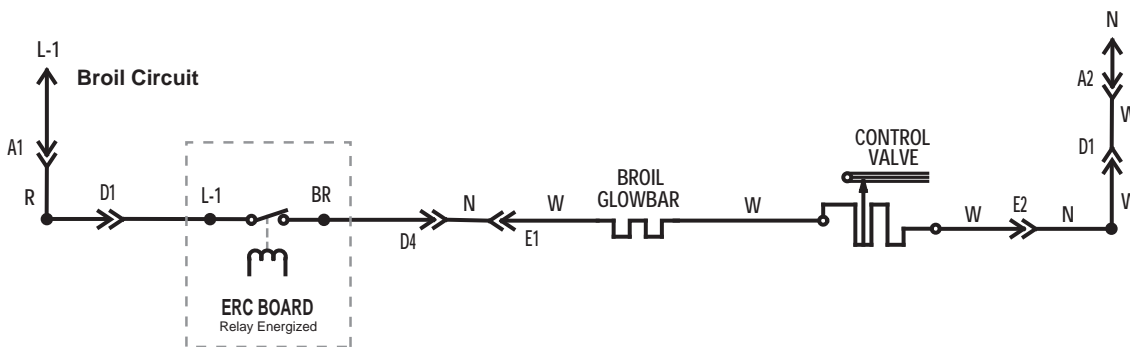
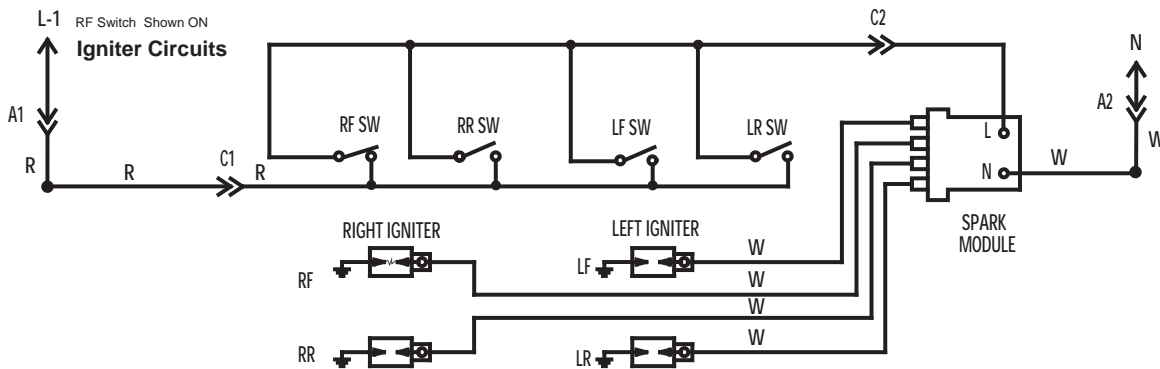
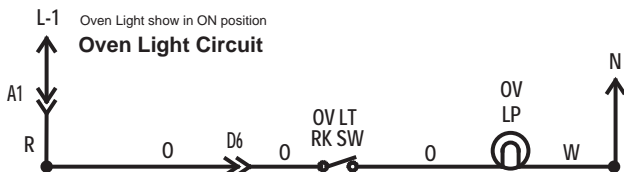

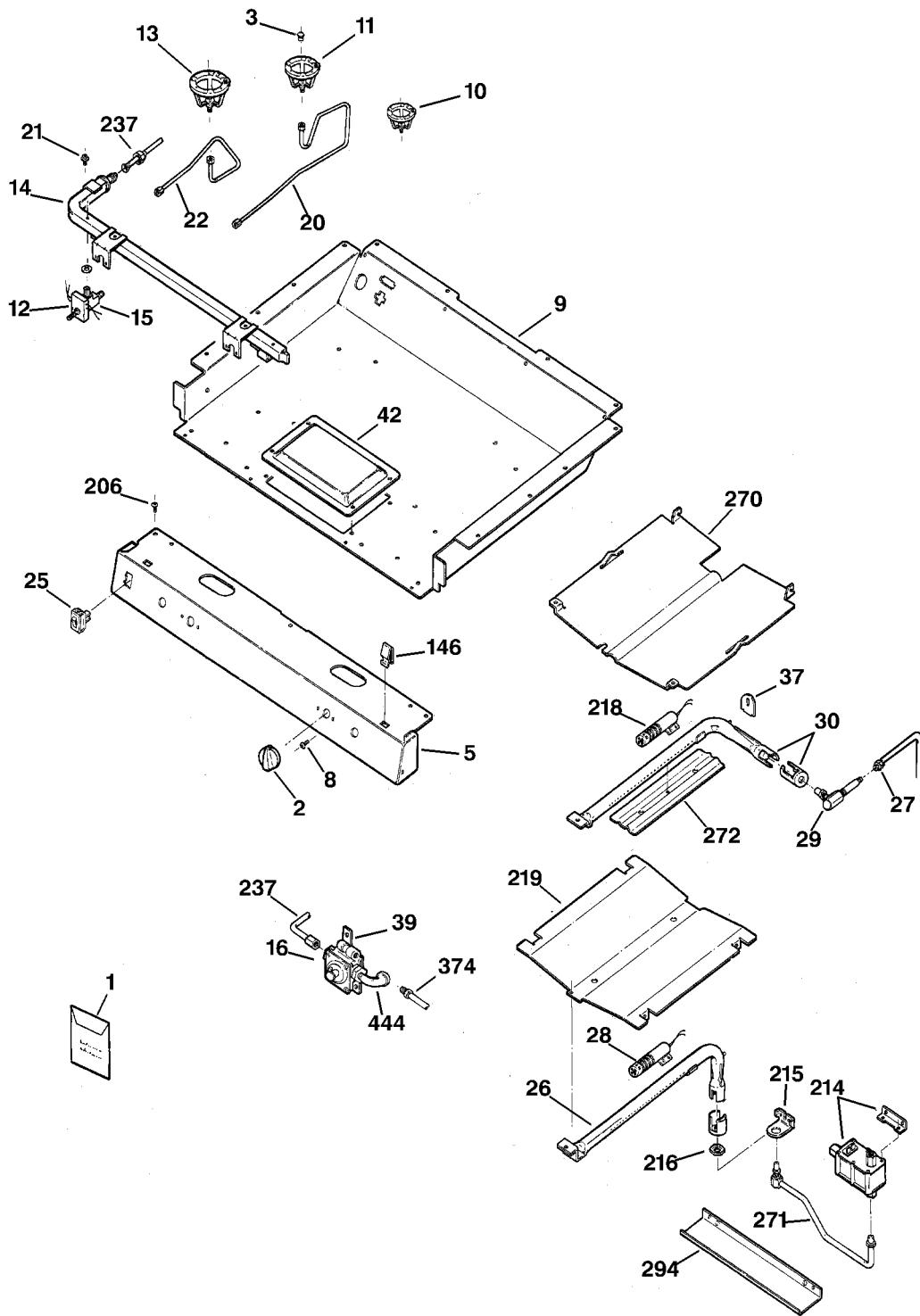

**Illustrated Parts Breakdown
JGBP85BEA**

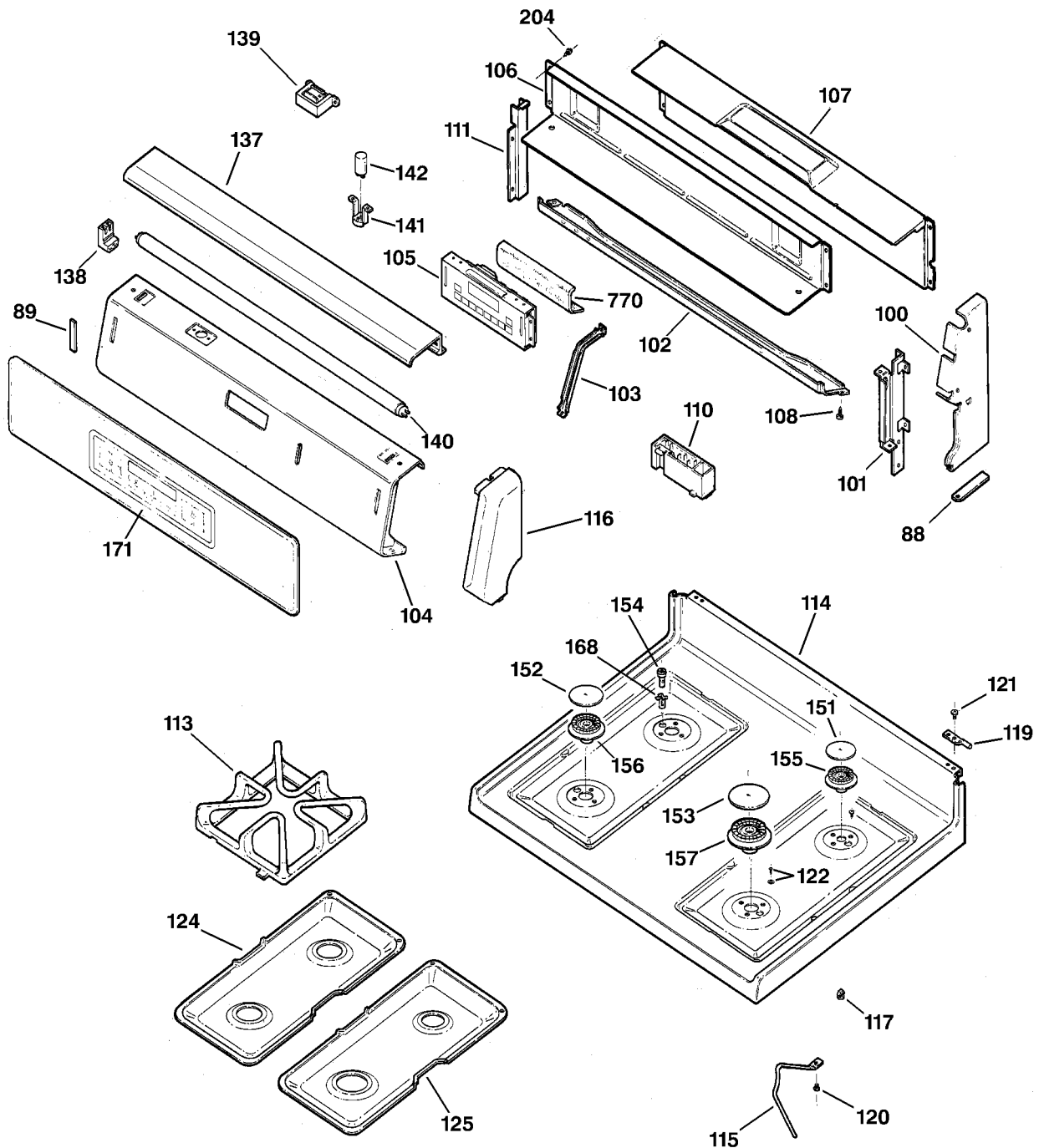

**Illustrated Parts Breakdown
JGBP85BEA**

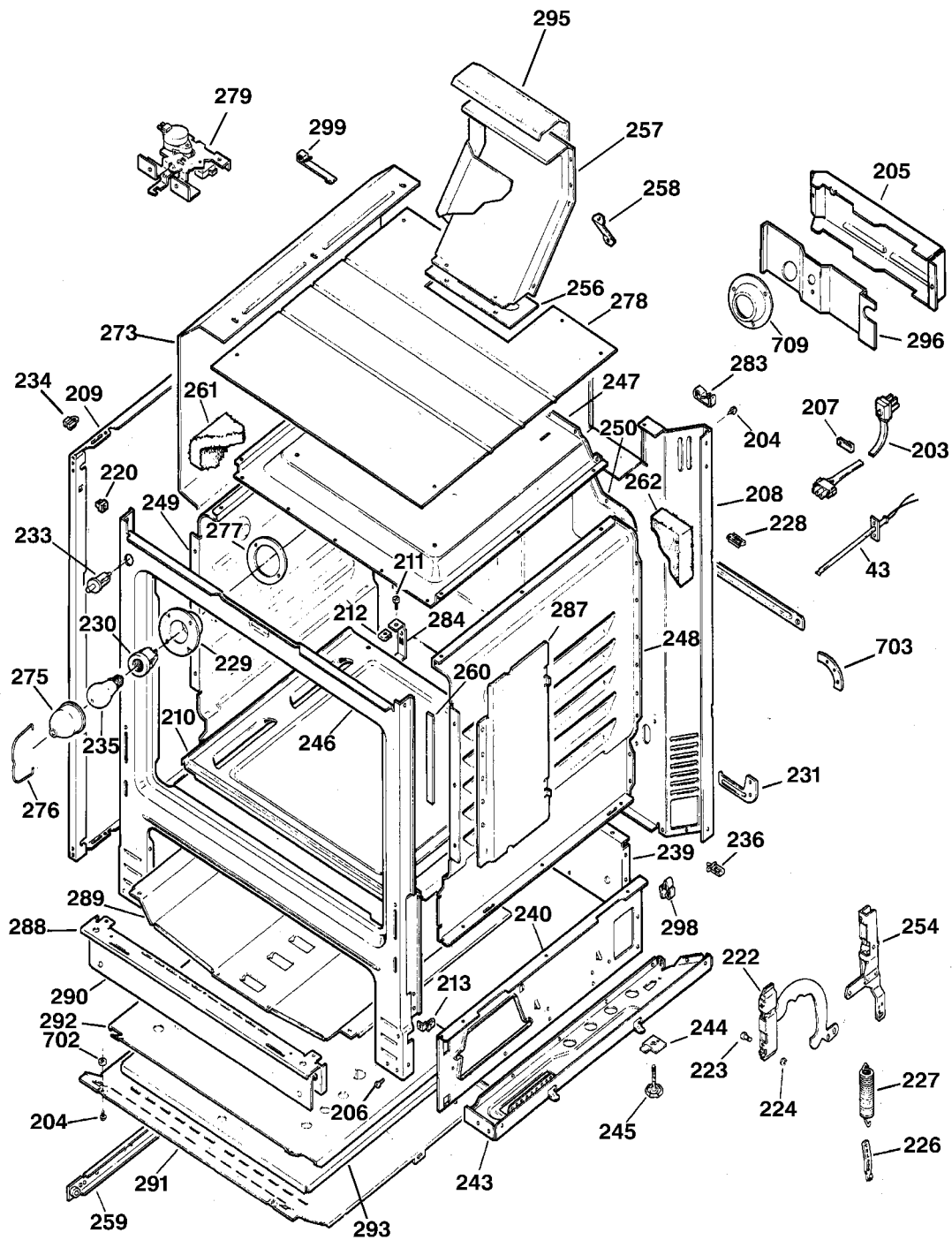

**Illustrated Parts Breakdown
JGBP85BEA**

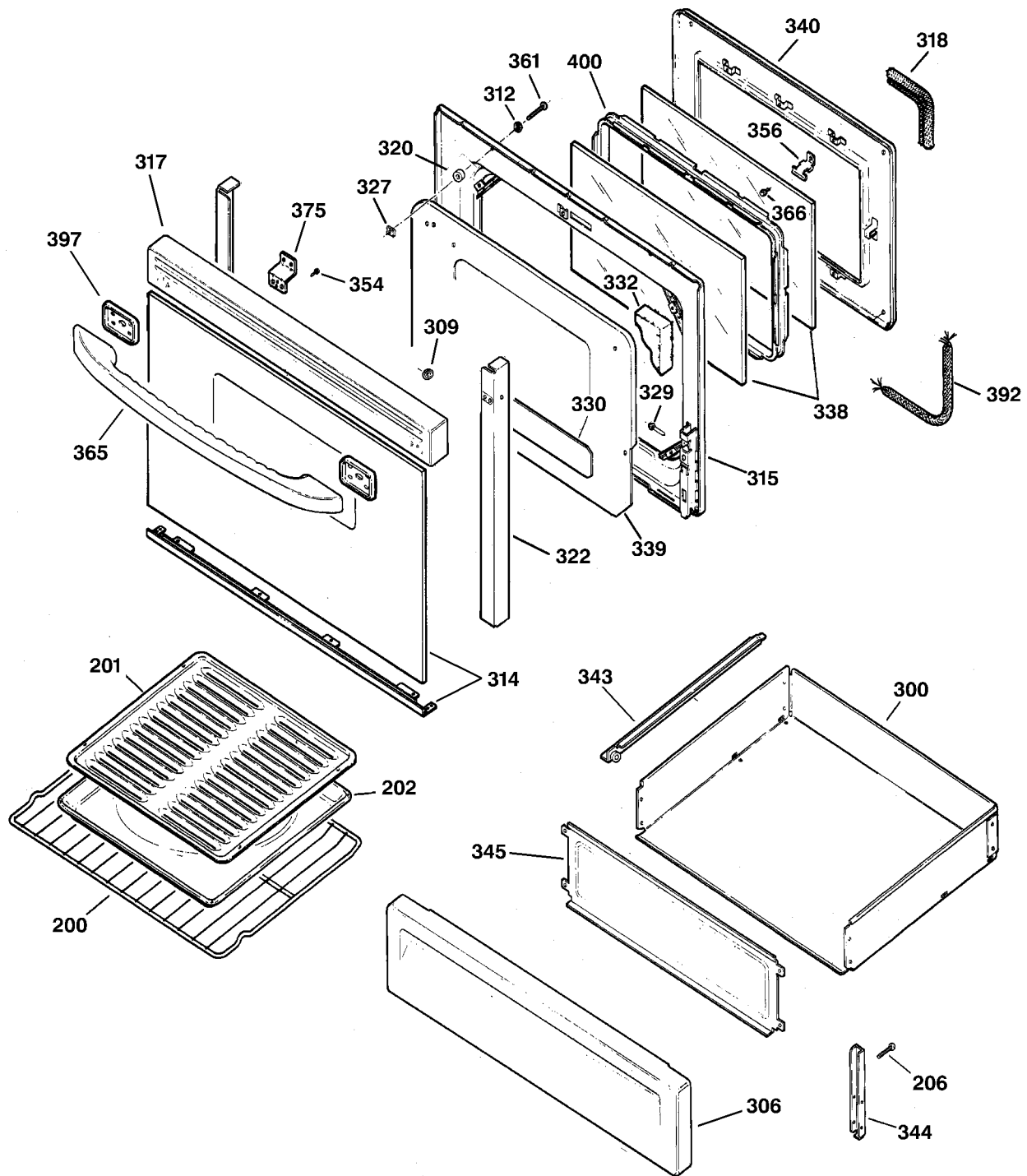

**Illustrated Parts Breakdown
JGBP85BEA**

ILLUSTRATED PARTS CATALOG

MODEL JGBP85BEA1BB

#	PART NUM.	DESCRIPTION	QTY
1	49-8856	MANUAL-USE & CARE	1
1	31-20639	MANUAL-MINI/ELEC. DIAG.	1
1	WB02K0020	BRACKET ASM ANTI-TIP	1
2	WB03K10043	KNOB-TOP BURNERS (BLK)	1
3	WB28K10031	ORIFICE-LP RIGHT REAR	1
3	WB28K10022	ORIFICE-NG LEFT REAR	1
3	WB28K10023	ORIFICE-LP LEFT REAR	1
3	WB28K10030	ORIFICE-NG FRONT RT & LT	2
3	WB28K10032	ORIFICE-LP FRONT RT & LT	2
3	WB28K10029	ORIFICE-NG RIGHT REAR	1
5	WB36X10071	PANEL-MANIFOLD (BLK)	1
8	WB01K10002	SCREW 8-32	4
9	WB63K0023	BOX BURNER	1
10	WB02K10007	BRACKET-BURNER SMALL	1
11	WB02K10006	BRACKET-BURNER	2
12	WB24K10003	SWITCH-BURNER VALVE	4
13	WB02K10008	BRACKET-BURNER LARGE	1
14	WB28K10028	MANIFOLD PIPE	1
15	WB21K0040	VALVE BURNER RT FRONT	1
15	WB21K0041	VALVE BURNER LEFT	2
15	WB21K0042	VALVE BURNER RT RR	1
16	WB19K10001	REGULATOR PRESSURE	1
20	WB28K10026	TUBE-BURNER RIGHT REAR	1
20	WB28K10027	TUBE-BURNER LEFT REAR	1
21	WB01K0083	SCREW MTG VALVE BURNER	4
22	WB28K10024	TUBE-BURNER RIGHT FRONT	1
22	WB28K10025	TUBE-BURNER LEFT FRONT	1
25	WB24K0003	SWITCH ROCKER (BLK)	1
26	WB16K0022	BURNER BAKE	1
27	WB28K0055	TUBE BURNER SUPPLY	1
28	WB13K0004	IGNITOR BURNER BAKE	1
28	WB01K0050	SCREW MTG IGNITOR	4
29	WB28K10018	ELBOW HI-BROIL	1
29	WB28K10019	ORIFICE	1
30	WB16K10008	BURNER BROIL	1
37	WB34K0014	COVER IGNITOR	1
39	WB02K0088	BRACKET REGULATOR	1
42	WB63K0022	COVER BURNER BOX	1
43	WB20K0004	SENSOR	1
88	WB02K0064	PAD FELT (BLK)	2
89	WB02K0062	PAD FELT (2")	2
100	WB07K10052	COVER END RT (BLK)	1
100	WB07K10051	COVER END LT (BLK)	1
101	WB37K0017	PLATE END RIGHT	1
101	WB37K0018	PLATE END LEFT	1
102	WB07K10056	LOWER FRONT TRIM (BLK)	1
103	WB02K10005	BRACKET-TIMER	2
104	WB36K10048	TRIM CONTROL (BLK)	1
105	WB11K10015	CONTROL ERC III	1
106	WB34K10003	COVER BACK UPPER	1
107	WB34K10001	COVER LOWER BACK	1
108	WB01X5364	SCREW (CR)	8
108	WB01X5716	SCREW 8-18 (BLK)	2
110	WB18K10005	HARNES-IGNITION HV	1
110	WB13K0025	SPARK MOD. TOP BURNERS	1
111	WB34K0005	COVER WIRE	1
113	WB31K10037	GRATE (BLACK)	2
114	WB62K10012	COOKTOP (BLK)	1
115	WB02K0091	SUPPORT RANGE TOP	2
116	WB07K10054	END-CAP RT (BLK)	1
116	WB07K10053	END-CAP LT (BLK)	1
117	WB02K0017	PIN LOCATOR	4
119	WB14K0005	PIN HINGE	2
120	WB01K0045	SCREW WASHER ASM	2
121	WB01K0001	SCREW	4
122	WB01K10008	SCREW CKTP	12
124	WB32K10009	PAN UNIT LFT (BLACK)	1

#	PART NUM.	DESCRIPTION	QTY
125	WB32K10001	PAN UNIT RT (BLACK)	1
137	WB34K10005	HOOD LAMP (BLK)	1
138	WB08K0006	SOCKET FLUORESCENT LAM	2
139	WB08K0003	BALLAST	1
140	WB08K0008	LAMP FLUORESCENT T-8	1
141	WB08K0010	BASE STARTER	1
142	WB06K0007	STARTER	1
146	WB02K0052	CLIP RANGE TOP	2
151	WB29K10009	CAP-BURNER SMALL (BLK)	1
152	WB29K10001	CAP-BURNER MED (BLK)	2
153	WB29K10006	CAP-BURNER LARGE (BLK)	1
154	WB13K10003	ELECTRODE-TOP BURNERS	4
155	WB16K10006	BURNER-SMALL	1
156	WB16K10005	BURNER	2
157	WB16K10007	BURNER-LARGE	1
168	WB01K10007	CLIP-ELECTRODE	4
171	WB57K10027	CRYSTAL & OVERLAY ASM	1
200	WB48K0004	RACK OVEN	1
201	WB48K0002	RACK BROILER PAN	1
202	WB49K0002	PAN BROILER	1
203	WB18K0007	LINE CORD	1
204	WZ04X0345	SCREW 8-18X5/8 HWX	13
204	WB01K0042	SCREW (BLK)	15
206	WB01K0021	SCREW	34
207	WB02K0036	CLAMP CABLE	1
208	WB63K0021	RANGE BACK	1
209	WB63K0052	PANEL SIDE (BLK)	2
210	WB53K0035	BOTTOM OVEN	1
211	WB01K0005	BOTTOM OVEN SCREW	2
212	WB01K0002	SPEED NUT	2
213	WB01K0003	NUT SPEED	2
214	WB19K0014	VALVE CONTROL	1
215	WB02K0065	BRACKET SAFETY VALVE	1
216	WB01K0006	NUT LOCK	2
218	WB13K0003	IGNITER BURNER BROIL	2
219	WB49K0044	FLAME SPREADER	1
220	WB02K0008	GROMMET	2
222	WB10K0012	HINGE ASM GUIDE	2
223	WB02X6195	PIN HINGE DOOR	2
224	WB02X1082	RING RETAINING	2
226	WB02K0011	HOOK DOOR SPRING	2
227	WB09K0005	SPRING DOOR	2
228	WB02X7066	CLIP WIRE	1
229	WB08K0001	HOUSING RECEPTACLE	1
230	WB08K0002	RECEPTACLE PUSH IN	1
231	WB02K0012	ARM ANTI-TIP	1
233	WB24K10004	SWITCH PLUNGER	1
234	WB02K0066	GUIDE SUPPORT RGTP	2
235	STD372401	OVEN LAMP	1
236	WB02K0022	CLIP WIRE	1
237	WB28K10021	TUBE MANIFOLD SUPPLY	1
239	WB63K0025	PANEL REAR BROIL	1
240	WB63K0002	PANEL SIDE BROIL RT	1
240	WB63K0003	PANEL SIDE BROIL LFT	1
243	WB63K0006	BASE SUPPORT RIGHT	1
243	WB63K0007	BASE SUPPORT LEFT	1
244	WB02K0001	BRACKET GLIDER	4
245	WB02X7701	LEVELING LEG	4
246	WB63K10002	FRAME WELD ASM	1
247	WB53K10004	OVEN TOP	1
248	WB53K0002	OVEN SIDE RIGHT	1
249	WB53K0003	OVEN SIDE LEFT	1
250	WB53K0019	OVEN BACK	1
254	WB10K0013	SUPPORT RIVET RT	1
254	WB10K0014	SUPPORT RIVET LFT	1
254	WB01K0053	SCREW MTG HINGE (TORX)	2
256	WB32K0001	GASKET VENT	1

ILLUSTRATED PARTS CATALOG

MODEL JGBP85BEA1BB

#	PART NUM.	DESCRIPTION	QTY
257	WB38K10001	VENT ASM	1
258	WB38K0002	BRACE VENT	1
259	WB39K10003	RAIL CHASSIS RIGHT	1
259	WB39K10004	RAIL CHASSIS LEFT	1
260	WB32K0002	GASKET OVEN SEAL LG	1
261	WB35K0007	INSULATION OVEN WRAP	1
262	WB35K0008	INSULATION OVEN BACK	1
270	WB49K10003	DEFLECTOR	1
271	WB28K0060	TUBE BURNER SUPPLY	1
271	WB28K0202	ORIFICE SPUD BURNER BAKE	1
272	WB34K0010	SHIELD BROIL	1
273	WB53K0011	GUARD INSUL. OVEN RIGHT	1
273	WB53K0012	GUARD INSULATION LEFT	1
274	WB01K0044	SCREW LATCH	2
275	WB08K0005	GLASS OVEN LAMP	1
276	WB02K0027	BAIL	1
277	WB32K0005	GASKET OVEN LIGHT	1
278		GUARD-TOP INSULATION	1
279	WB02K10010	LATCH AUTOMATIC	1
283	WB02K0031	CLIP CABLE	1
284	WB02K0032	BRACKET SUPPORT	2
287	WB34K0030	GUARD RADIATION RT	1
287	WB34K0031	GUARD RADIATION LFT	1
288	WB63K0015	BRACE	1
289	WB34K0011	SHIELD HEAT LOWER	1
290	WB34K0012	SHIELD RADIATION	1
291	WB63K0016	GUARD BOTTOM	1
292	WB63K0017	GUARD BOTTOM INNER	1
293	WB63K0018	GUARD BOTTOM MIDDLE	1
294	WB63K0019	VALVE GUARD BOTTOM	1
295	WB35K10003	VENT INSULATION	1
296	WB34K0013	SHIELD HEAT INNER	1
298	WB02K0037	CLIP SPACER	2
299	WB02K0038	CLIP WIRE	3
300	WB58K0001	DRAWER BODY ASM	1
306	WB55K10001	PANEL DRAWER (BLK)	1
309	WB01X0560	WASHER	2
312	WB01X0119	WASHER CONTOURED	2
314	WB57K10028	GLASS DOOR (BLK)	1
315	WB55K0025	LINER ASM WELD DOOR	1
317	WB07K10055	TRIM-VENT DOOR (BLK)	1
318	WB04K0001	GASKET DOOR	1
320	WB02K0014	SPACER	2
322	WB07K10016	TRIM DOOR (AL)	1
322	WB07K10019	TRIM DOOR (BLK)	1
327	WB01X5736	SPEED NUT	2
329	WB01X0558	SCREW NAIL POINT	2
330	WB35K0033	REFLECTOR	1
330	WB35K0022	REFLECTOR 9.5"	2
332	WB35K0024	INSULATION SIDE DOOR	2
332	WB35K0025	INSULATION BOTTOM DOOR	2
338	WB56K0020	WINDOW PACK KIT LG	2
339	WB56K0012	GUARD INSULATION	1
340	WB55K0013	PANEL ASM WELD INNER	1
343	WB39K0041	RAIL DRAWER LEFT	1
343	WB39K0042	RAIL DRAWER RIGHT	1
344	WB39K0020	BRACKET MOUNTING DRAWR	2
345	WB35K10007	DEFLECTOR DRAWER	1
354	WB01K10009	SCR 10-32 MTG HANDLE	2
356	WB02K0069	CLIP WINDOW	4
361	WB01K0031	SCREW	2
365	WB15X5227	HANDLE DOOR BLACK	1
366	WB01X0593	SCREW - DOOR ASM (4 PER)	4
374	WB28K0150	TUBE VALVE SUPPLY	1
375	WB02K10009	BRACKET DOOR	2
392	WB04K0003	SEAL-ROPE	1
397	WB07K10057	TRIM HANDLE (BLACK)	2

#	PART NUM.	DESCRIPTION	QTY
400	WB34K5196	WINDOW SPACER - LG	1
444	WB28K0061	ELBOW 90 DEGREES	1
700	WB02K0034	CLIP VENT	3
702	WB01K0024	WASHER (FELT)	2
703	WB02K0041	BRACKET OVEN	2
709	WB08K0004	RETAINER INSULATION LAMP	1
770	WB35K10004	INSULATION-CONTROL	1

Glow Bar Glows But No Ignition

Shut gas supply off to the range.
Turn oven into **BAKE** cycle. Check amperage of ignitor circuit with a clamp on amp meter

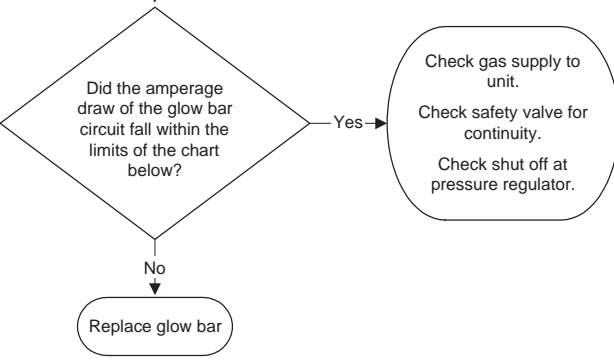
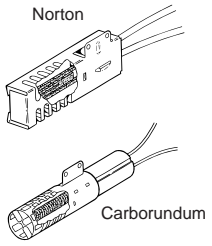

GLOW BAR NORMAL OPERATING LIMITS CHART	
Norton glow bar	= 3.2 to 3.7 amps
Carborundum	= 2.5 to 3.0 amps

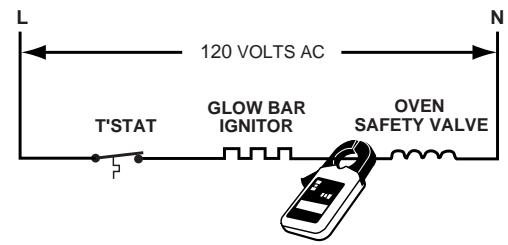

Glow Bar Not Glowing - No Bake

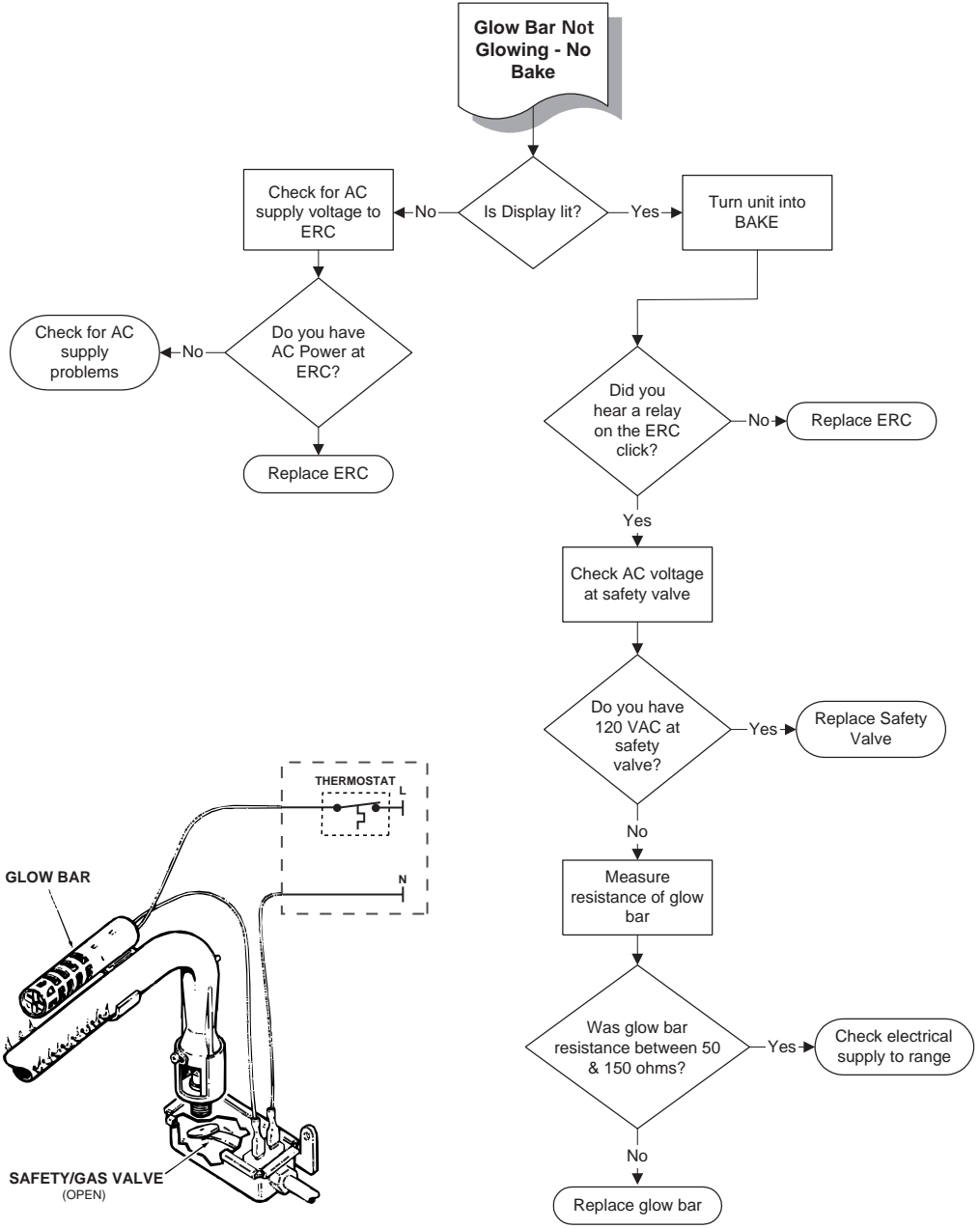

XL44™: Gas Ranges

A Full Range of New Features:

See pages 8 & 9 of this service guide for model specific features

GE Profile™ GE

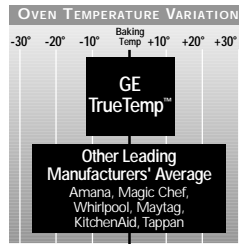

TrueTemp™ System
"The Most Accurate Oven In America"

Enhanced Broil System provides improved broil performance

Professional cooktop grate provides preparation and cooking convenience



Precise Simmer Burner with 600 BTUs allows for low, even heat distribution for delicate foods and sauces



Two Maximum Output Burners, with 12,000 BTUs, provide high output for fast heat-up and boiling



Largest Useable Oven Capacity,* room for cooking an entire meal
*Among manufacturers' brands



Digipad entry provides digital precision with easy-to-set controls



Digital temperature display for accurate temperature readout



Sealed Burner Design helps contain spills from dripping beneath cooktop for easy cleanup



Sixth Embossed Rack Position increases cooking flexibility



Digital temperature display for accurate temperature readout



Extra-Large Broiler Pan with Grid allows for a large-capacity broiling area



Cooktop lifts up for access to easy-clean seamless, porcelain-enameled subtop

GE—Continuing the Tradition of Innovation



Thomas Edison

When you make GE products part of your home, you join millions of people throughout the world, people who know through experience that at GE—*We bring good things to life.*

In 1876, Thomas Edison took a revolutionary idea and created the light bulb—a device that would change the world forever.

And while the small company he founded over a hundred years ago has grown into an international business, GE still maintains a dedication to principles upon which it was founded—innovation, quality and products that set new standards. Its remarkable history encompasses vision, determination and a well-earned reputation for quality.

For over 100 years, GE has been the source of premier products, many of them "firsts" in the industry. Some notable technological developments and range introductions include:

- 1907 GE marketed a full line of cooking devices to the consumer
- 1928 One of the most important range developments—the first Calrod® heating elements
- 1934 The electric range had gained household acceptance
- 1950 Electric ranges featured doubled ovens
- 1956 GE promoted a new era of all-automatic cooking—electronics
- 1963 GE introduced the most important invention in the major appliance industry—the "Self-Cleaning Oven"
- 1976 New free-standing microwave cooking center combined upper microwave oven with lower self-cleaning conventional oven
- 1980 Introduced "TimeMaker" range with combination conventional/ microwave oven
- 1990 XL44™—Revolutionized industry by introducing largest capacity oven, upswept cooktop and Big View window
- 1997 Introduced TrueTemp™ System: The Most Accurate Oven In America

Today, that tradition of innovation continues and we intend to carry it forward to continue earning our leading reputation.