

Service

This manual is to be used by qualified appliance technicians only. Maytag does not assume any responsibility for property damage or personal injury for improper service procedures done by an unqualified person.

1100 W - 2005 International Countertop Commercial Microwave Ovens

This Base Manual covers general information.

Refer to individual Technical Sheet for information on specific models.

This manual includes, but is not limited to the following:

DECS11MA	P1330217M
DES11EA	P1330218M
DFS11EA	P1330220M
RCS511A	P1330214M
RS511MB	P1330211M
RS511P	P1330212M
RFS511SW2A	P1330223M
UCS11MA	P1330228M
UFS11EA	P1330230M
URCS511A	P1330226M
URS511MB	P1330224M
URS511P	P1330225M
US11EA	P1330229M

Important Information

Important Notices for Servicers and Consumers

Maytag will not be responsible for personal injury or property damage from improper service procedures. Pride and workmanship go into every product to provide our customers with quality products. It is possible, however, that during its lifetime a product may require service. Products should be serviced only by a qualified service technician who is familiar with the safety procedures required in the repair and who is equipped with the proper tools, parts, testing instruments and the appropriate service information. **IT IS THE TECHNICIANS RESPONSIBILITY TO REVIEW ALL APPROPRIATE SERVICE INFORMATION BEFORE BEGINNING REPAIRS.**



WARNING

To avoid risk of severe personal injury or death, disconnect power before working/servicing on appliance to avoid electrical shock.

To locate an authorized servicer, please consult your telephone book or the dealer from whom you purchased this product. For further assistance, please contact:

Service Support Center

Contact your local product distributor or visit the Web site at www.amanacommercial.com.

Recognize Safety Symbols, Words, and Labels



DANGER

DANGER—Immediate hazards which **WILL** result in severe personal injury or death.



WARNING

WARNING—Hazards or unsafe practices which **COULD** result in severe personal injury or death.



CAUTION

CAUTION—Hazards or unsafe practices which **COULD** result in minor personal injury, product or property damage.

Table of Contents

Important Information	2	Disassembly Procedures	
Important Safety Information	4-8	Disconnecting Wire Terminals	25
Wiring	8	Outer Case	25
Earthing Instructions	8	Door Assembly	26
Servicing of Earthing Products	8	Door Disassembly	26
General Information		Control Panel	27
Placement of the Oven	9	Interlock Switches	27
Radio Interference	9	High Voltage Capacitor	28
Earthing Instructions	9	Diode/Circuit Protector	28
Microwave Oven Description	10	Transformer	29
Troubleshooting Procedures	11-16	Fuse / Fuse Block / Filter Assembly	29
Service information		Magnetron	29
Proper Handling of Magnetron Tubes	17	Blower Motor or Wheel	30
Magnetron Failure Modes	17	Splatter Shield	30
Microwave Leakage Testing		Antenna	30
Equipment	18	Stirrer Motor	30
Procedure For Measuring Radiation Leakage	18	Magnetron Thermal Cut-Out (TCO)	31
Measurement With the Outer Panel Removed	18	Cavity Thermal Fuse	31
Measurement With a Fully Assembled Oven	18	Tray Replacement	31
Record Keeping and Notification After Measurement	18	Oven Light Removal	31
Troubleshooting		Appendix A	
Operating Instructions for the Holaday		Quick Reference Guides	A-2 – A-5
HI1501, HI1510, HI1710, and HI1801	19		
Testing Procedures	20-24		

Important Safety Information

PRECAUTIONS TO AVOID POSSIBLE EXPOSURE TO EXCESSIVE MICROWAVE ENERGY

- (a) **DO NOT** attempt to operate this oven with the door open since open-door operation can result in harmful exposure to microwave energy. It is important not to defeat or tamper with the safety interlocks.
- (b) **DO NOT** place any object between the oven front face and the door or allow soil or cleaner residue to accumulate on sealing surfaces.
- (c) **DO NOT** operate the oven if it is damaged. It is particularly important that the oven door close properly and that there is no damage to the: (a) Door (bent), (b) hinges and latches (broken or loosened), (c) door seals and sealing surfaces.
- (d) The oven should **NOT** be adjusted or repaired by anyone except properly qualified service personnel.

PRECAUTIONS A PRENDRE POUR EVITER LES RISQUES D'EXPOSITION A DES QUANTITES EXCESSIVES D'ENERGIE MICRO-ONDE

- (a) **NE PAS** essayer de faire marcher le four avec la porte ouverte car cela risque d'exposer l'utilisateur à une quantité nocive d'énergie micro-onde. Ne jamais supprimer ou altérer les verrouillages de sécurité.
- (b) **NE RIEN METTRE** entre la face avant du four et la porte et ne pas laisser de saletés ou de produits de nettoyage s'accumuler sur les surfaces d'étanchéité.
- (c) **NE JAMAIS** faire fonctionner le four s'il est endommagé. Il est tout particulièrement important que la porte du four se ferme correctement et que les éléments suivants fonctionnent sans problème : a) la porte (faussée), b) les charnières et les verrouillages (cassés ou desserrés), c) les joints et les surfaces d'étanchéité de la porte.
- (d) Le four **NE DOIT ETRE** réparé que par des réparateurs qualifiés.

PRECAUCIONES PARA EVITAR LA POSIBLE EXPOSICION EXCESIVA A LA ENERGIA DE MICROONDAS

- (a) **NO** intente hacer funcionar este horno con la puerta abierta ya que podría resultar en una exposición dañina a la energía de microondas. Es muy importante no pasar por alto o averiar los interruptores de seguridad.
- (b) **NO** coloque ningún objeto entre el frente del horno y la puerta. Tampoco permita que suciedad o residuos de limpiador se acumulen en las superficies de sellado del aparato.
- (c) **NO** haga funcionar el horno si éste estuviera averiado. Es de particular importancia que la puerta del horno se cierre correctamente y que no existan daños en: (a) la puerta (dobladuras), (b) las bisagras y el pestillo (rotos o flojos), (c) los sellos de las puertas y otras superficies de sellado.
- (d) El horno **NO** deberá ser ajustado o reparado por ninguna persona excepto personal de servicio propiamente calificado.

VORSICHTSMASSNAHMEN ZUM SCHUTZ GEGEN MIKROWELLENSTRAHLUNG

- (a) **NICHT** versuchen, den Herd mit offener Tür zu betreiben, da Sie dadurch schädlicher Mikrowellenstrahlung ausgesetzt werden können. Auf keinen Fall die Sicherheitsverriegelung unwirksam machen oder ändern.
- (b) **KENE** Gegenstände zwischen Herd und Tür einklemmen oder Schmutz und Rückstände von Reinigungsmitteln auf den Dichtflächen sich ansammeln lassen.
- (c) **KEINEN** beschädigten Herd benutzen. Es ist besonders wichtig, daß die Herdtür richtig schließt und die folgenden Teile nicht beschädigt sind: (a) Tür (z.B. verbogen), (b) Scharniere und Klinken (z.B. gebrochen oder lose), (c) Türdichtungen und Dichtflächen.
- (d) Das Gerät **NUR** von qualifiziertem Kundendienstpersonal reparieren lassen.

Important Safety Information

VAROITUS MIKROAALTOSÄTEILYÄ

Käyttäjä ei saa joutua alttiiksi mikroaaltoenergialle, jota voi säteillä magnetronista tai muusta mikroaaltoja kehittävästä laitteesta, jos sitä käytetään väärin tai jos se kytketään väärin. Kaikkien mikroaaltoliitäntöjen sekä syöttöettä ulostulopuolella, aaltoputkien laippojen ja tiivisteiden tulee

olla varmistettuja. Mikroaaltouunia ei saa koskaan käyttää ilman kuormaa, jossa mikroaaltoenergiaa kuluu. Avoimeen aaltoputkeen tai antenniin ei saa koskaan katsoa virran ollessa kytkettynä.

VARNING FÖR MIKROVÅGSSTRÅLNING

Mikrovågsenergi kan stråla från magnetronen eller från annan mikrovågsgenererande anordning om den används eller ansluts felaktigt. Alla anslutningar för mikrovåg, såsom flänsar och tätningar måste vara betryggande ur säkerhets-

synpunkt. Starta aldrig anordningen utan mikrovågsabsorberande belastning. Mikrovågsstrålning från en öppen vågledare eller antenn har sådan strålningstäthet att uppenbar skaderisk föreligger.

ADVARSEL FOR MIKROBØLGESTRALING

Mikrobølgeenergi kan stråle fra magnetronen eller annen mikrobølgeproduserende anordning ved feilkopling eller feil bruk. Alle mikrobølgeinntak og -uttaksforbindelser, flenser og pakninger, må være sikkerhetsmessig betryggende

utført. Anordningen må aldri startes uten mikrobølgeabsorberende belastning. Se aldri inn mot en åpen bølgeleder eller antenne mens apparatet er i drift.

FORSIGTIG MIKROBØLGESTRÅLING

Undgå at blive udsat for stråling fra mikrobølgegeneratoren eller andre dele som fører mikrobølgeenergi.

Important Safety Information

PRECAUZIONI PER EVITARE L'EVENTUALE ECCESSIVA ESPOSIZIONE ALLE MICROONDE

- (a) **NON** cercare di far funzionare questo forno con lo sportello aperto: ciò può causare l'esposizione nociva alle microonde. È importante non danneggiare o manomettere i dispositivi di sicurezza.
- (b) **NON** porre alcun oggetto fra il lato anteriore del forno e lo sportello o permettere il depositarsi di sporcizia o residui sulle superfici di tenuta.
- (c) **NON** usare un forno danneggiato. È molto importante che lo sportello del forno si chiuda bene e che non vi siano danni a: (a) sportello (piegato); (b) cardini e dispositivi di chiusura (rotti o allentati); (c) guarnizioni dello sportello e delle superfici di tenuta.
- (d) Il forno va regolato o riparato **ESCLUSIVAMENTE** da personale d'assistenza debitamente qualificato.

VOORZORGSMATREGELEN TER VOORKOMING VAN MOGELIJKE BLOOTSTELLING AAN OVERMATIGE MICROGOLFENERGIE

- (a) Probeer **NIET** om deze magnetron met de deur open te gebruiken. daar gebruik met open deur schadelijke blootstelling aan microgolffenergie ten gevolge kan hebben. Het is belangrijk dat u de veiligheidssluitingen nooit onklaar maakt of ermee knoeit.
- (b) Plaats **GEEN** voorwerpen tussen de voorkant van de oven en de deur. Zorg dat geen vuil of schoonmaakmiddel op de sluitvlakken achterblijft.
- (c) Gebruik de magnetron **NIET** indien hij beschadigd is. Het is vooral belangrijk dat de deur goed sluit en dat er geen beschadigingen zijn aan: (a) de deur (verbogen), (b) de scharnieren en sloten (gebroken of los), (c) de deurdichtingen en sluitvlakken.
- (d) De magnetron mag **UITSLUITEND** door daartoe bevoegd servicepersoneel bijgesteld en gerepareerd worden.

Important Safety Information



CAUTION

Read the following information to avoid possible exposure to microwave radiation:

The basic design of the Amana and Menumaster microwave ovens make it an inherently safe device to both user and servicer. However, there are some precautions which should be followed when servicing the microwave oven to maintain this safety. These are as follows:

1. Always operate the unit from an adequately earthed outlet. Do not operate on a two-wire extension cord.
2. Before servicing the unit (if unit is operable), perform the microwave leakage test.
3. The oven should never be operated if the door does not fit properly against the seal, the hinges or hinge bearings are damaged or broken; the choke is damaged, (pieces missing, etc.); or any other visible damage can be noted. Check the choke area to ensure that this area is clean and free of all foreign matter.
4. If the oven operates with the door open and produces microwave energy, take the following steps.
 - A. Tell the user not to operate the oven.
 - B. Contact Maytag immediately.
5. Always have the oven disconnected when the outer case is removed except when making the "live" tests called for in this Service Manual. Do not reach into the equipment area while the unit is energized. Make all connections for the test and check them for tightness before plugging the cord into the outlet.
6. Always earth the capacitors on the magnetron filter box and H. V. Capacitor with an insulated-handle screwdriver before working in the high voltage area of the equipment compartment. Some types of failures will leave a charge in these capacitors and the discharge could cause a reflex action which could make you injure yourself.
7. In the area of the transformer, capacitor, diode, and magnetron there is HIGH VOLTAGE. When the unit is operating, keep this area clean and free of anything which could possibly cause an arc or earthing, etc.
8. Do not for any reason defeat the interlock switches. There is no valid reason for this action at any time; nor will it be condoned by Maytag.
9. IMPORTANT: Before returning a microwave to a customer, check for proper switch interlock action. The primary and secondary switches MUST open when the door is actuated. The monitor switch MUST close at a $\frac{1}{64}$ -inch (0.5 mm) when the door is opened.
10. Before returning a microwave to a customer, verify the door spacing is reasonably uniform along the top, bottom, and sides, and that it measures $\frac{1}{64}$ -inch (0.5 mm) or less.
11. The Amana or Menumaster microwave oven should never be operated with:
 - Any components removed and/or bypassed.
 - Any of the safety interlocks found to be defective.
 - Any of the seal surfaces defective, missing, or damaged.
12. To ensure that the unit does not emit excessive microwave leakage and to meet the Department of Health Human Service guidelines, check the oven for microwave leakage using leakage monitor as outlined in the instructions. The maximum leakage level allowed is $4\text{mW}/\text{cm}^2$.
13. If servicer encounters an emission reading over $4\text{mw}/\text{cm}^2$ the servicer is to cease repair and contact the Maytag Service Department immediately for further direction. Maytag will contact the proper Government Agency upon verification of the test results.

Important Safety Information



WARNING

Precautions to be observed before and during servicing to avoid possible exposure to excessive microwave energy, or electrical shock disconnect power to oven.

- (A) Do not operate or allow oven to be operated with door open.
- (B) Make the following safety checks on all ovens to be serviced before activating the magnetron or other microwave source, and make repairs as necessary:
 - Interlock operation
 - Proper door closing
 - Seal and sealing surfaces (arcing, wear, and other damage)
 - Damage to or loosening of hinges and latches
 - Evidence of dropping or abuse
- (C) Before turning on microwave power for any service test or inspection within the microwave generating compartments, check the magnetron, waveguide or transmission line, and cavity for proper alignment, integrity, and connections.
- (D) Any defective or misadjusted components in the interlock, monitor, door seal, and microwave generation and transmission systems shall be repaired, replaced or adjusted by procedures described in this manual before oven is released to the consumer.
- (E) Check microwave leakage to verify compliance with the federal performance standard should be performed on each oven prior to release to the consumer.

Wiring

Good service practice is to never route wiring over terminals and/or sharp edges. This applies to any wiring without regard to the circuit voltage. Wire insulation material and thickness is designed and regulated for electrical spacing purpose only, but cannot always be relied upon because of possible cuts and/or abrasions, which can occur during servicing.



WARNING

To avoid risk of electrical shock, personal injury or death, make sure these earthing instructions are followed.

Earthing Instructions



WARNING

Do not remove earthing prong when installing earthed appliance in a home or business that does not have three wire earthing receptacle, under no condition is earthing prong to be cut off or removed. It is the personal responsibility of the consumer to contact a qualified electrician and have properly earthed three prong wall receptacle installed in accordance with appropriate electrical codes

Should a two prong adapter plug be required temporarily, it is the personal responsibility of the consumer to have it replaced with properly earthed three prong receptacle or the two prong adapter properly earthed by a qualified electrician in accordance with appropriate electrical codes.

Servicing of Earthed Products

The standard accepted color coding for earthing wires is GREEN or GREEN WITH YELLOW STRIPE. These earth leads are NOT to be used as current carrying conductors. It is extremely important that the technician replace any and all earths prior to completion of the service call. Under no condition should earth wire be left off causing a potential hazard to technicians and consumer.

General Information

Placement of the Oven

Do not install microwave next to or above source of heat, such as a deep fat fryer. This could cause the microwave to operate improperly and could shorten the life of electrical components.

Install microwave on a level countertop surface.

Do not block or obstruct oven filter. Allow access for cleaning.

All air vents must be kept clear during cooking. If air vents are covered during operation the oven may overheat. In this case, a sensitive thermal safety device automatically turns the oven off. The oven will be inoperable until the oven has cooled sufficiently.

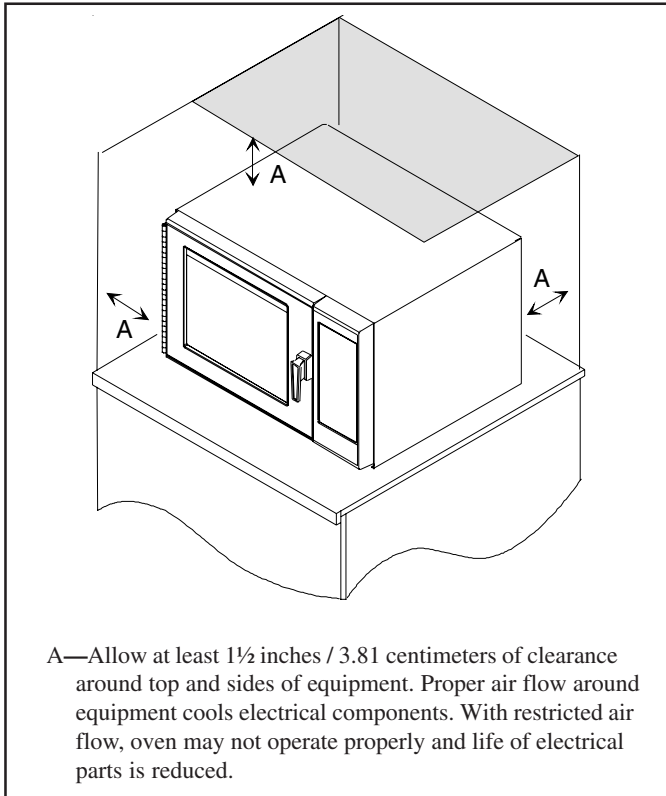

Radio Interference

Microwave oven operation may cause interference to radio, television, or similar equipment. Reduce or eliminate interference by doing the following:

- Clean the door and sealing surfaces of microwave oven according to instructions in “Care and Cleaning” section.
- Place radio, television, etc. as far as possible from the microwave oven.
- Use a properly installed antenna on radio, television, etc. to obtain stronger signal reception.

Earthing Instructions

This appliance **MUST** be earthed. If an electrical short circuit occurs, earthing reduces the risk of electric shock by providing an escape wire for the electric current. The cord for this appliance has a earthing wire with a earthing plug. Place the plug into an outlet that is properly installed and earthed. Do not use a two-prong adapter.

WARNING

To avoid risk of electric shock, personal injury or death, do not alter the plug and use earthing plug properly.

Consult a qualified electrician if you do not understand the earthing instructions or if you wonder whether the appliance is properly earthed.

Keep the electrical power cord dry and do not pinch or crush it in anyway.

The wires in the power cord are colored in accordance with the following code:

- | | |
|------------------------|----------------|
| • Green/Yellow: | Earth |
| • Blue: | Neutral |
| • Brown: | Live |

General Information

Receptacle

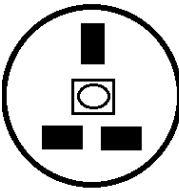

Plug

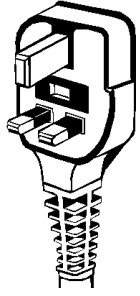

230 V / 13 AMP

Equipment requires a
230 VAC, 50 Hz, 13 amp power supply

Receptacle

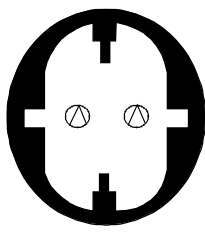

Plug

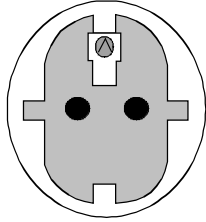

230 V / 16 AMP

Equipment requires a
230 VAC, 50 Hz, 16 amp power supply

Do not use an extension cord. If the product power cord is too short, have a qualified electrician install a three-prong receptacle. This unit should be plugged into a separate dedicated 230 VAC / 50 Hz power supply. If other equipment is on the same circuit, an increase in cooking times may be required and fuse can be blown.

Microwave Oven Description

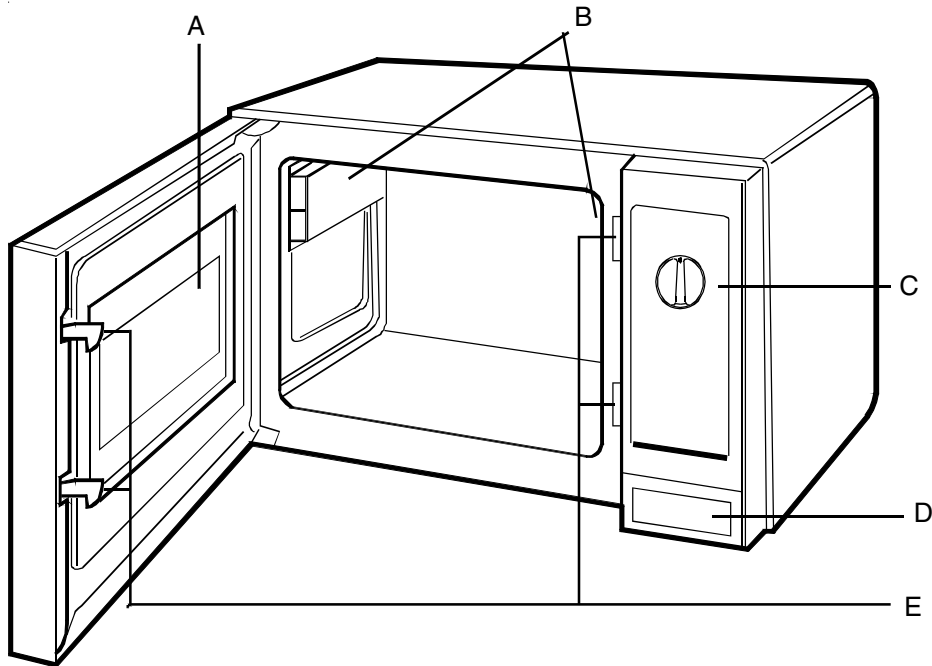

A—Window door screen
B—Spatter shields
C—Control panel (Electronic or Dial)
D—Door open button
E—Safety door lock system

Troubleshooting Procedures

When you get a complaint from customers, evaluate the complaint carefully. If the following symptoms apply, instruct the customer in the proper use of the microwave oven. This can eliminate an unnecessary service call.



CAUTION

- Verify proper earthing before checking for trouble.
- Be careful of the high voltage circuit.
- Discharge the high voltage capacitor.
- When checking the continuity of the switches or the high voltage transformer, disconnect one lead wire from these parts and then check continuity with the AC plug removed. To do otherwise may result in a false reading or damage to your meter.
- Do not touch any part of the circuit on the controller, since static electric discharge may damage the control panel. Always touch yourself to earth while working on this panel to discharge any static charge built up in your body.

Condition	Cause	Remedy
Microwave oven does not work.	<ul style="list-style-type: none"> • Inserting multiple plugs into one outlet and using them at the same time (blown fuse or breaker). • Microwave oven plug is not inserted tightly. 	<ul style="list-style-type: none"> • Avoid using other electrical appliances when you use the microwave oven. • Insert microwave oven plug securely.
Output power is too low.	<ul style="list-style-type: none"> • Low AC input voltage. • Food temperature is too low. 	<ul style="list-style-type: none"> • Use the microwave oven at adequate line voltage. • This may not be a defect. It is possible that the food should be cooked for a longer time period.
Sparks occur.	<ul style="list-style-type: none"> • Using metallic ware and allowing it to touch the oven wall. • Ceramic ware trimmed in gold or silver is used. 	<ul style="list-style-type: none"> • Do not use metallic ware for cooking. • Do not use any type of cookware with metallic trimming.
Uneven cooking.	Inconsistent food thickness, inconsistent fat or moisture distribution within the food products.	<ul style="list-style-type: none"> • Use plastic wrap or lid. • Stir once or twice while cooking soup, cocoa, milk, etc.

Troubleshooting Procedures

Trouble 1: The following visual conditions indicate a probable failed control circuit.

1. Incomplete segments.
 - Segment missing.
 - Partial segment missing.
 - Digit flickering (Note: Slight flickering is normal.)
2. Colon does not turn on or blink.
3. A distinct change in the brightness of one or more numbers in display.
4. One or more digits in the display are not lighting.
5. Display indicates a number different from one touched, for example, key in 5 and 3 appears in the display.
6. Specific numbers (for example 7 or 9) will not display when key pad is touched.
7. Display does not count down with time blinking or up with clock operation.
8. Display obviously jumps in time while counting down.
9. Display counts down too fast while cooking.
10. Each indicator light does not turn on after setting cooking cycle.
11. Display time of day does not reappear when cooking is finished.

Condition	Check	Result	Cause	Remedy
No input can be programmed.	Check the connection between keypad and controller.	<ul style="list-style-type: none"> • Continuity • No continuity 	<ul style="list-style-type: none"> • Failed controller. • Loose connection. 	<ul style="list-style-type: none"> • Replace controller. • Repair connection.
<ol style="list-style-type: none"> 1. Some inputs cannot be programmed. 2. Display shows a number or figure different from one touched. 3. Random programming when touching other pads. 4. Display is fixed at some figure and can not accept any input. 	Test keypad (see Testing Procedure section).	<ul style="list-style-type: none"> • Results not as specified. • Results are per specifications. 	<ul style="list-style-type: none"> • Failed keypad. • Failed controller. 	<ul style="list-style-type: none"> • Replace keypad. • Replace controller.

Troubleshooting Procedures (Electronic Models)

Trouble 2: Oven does not operate at all, display window does not display any digits, and no input is accepted.

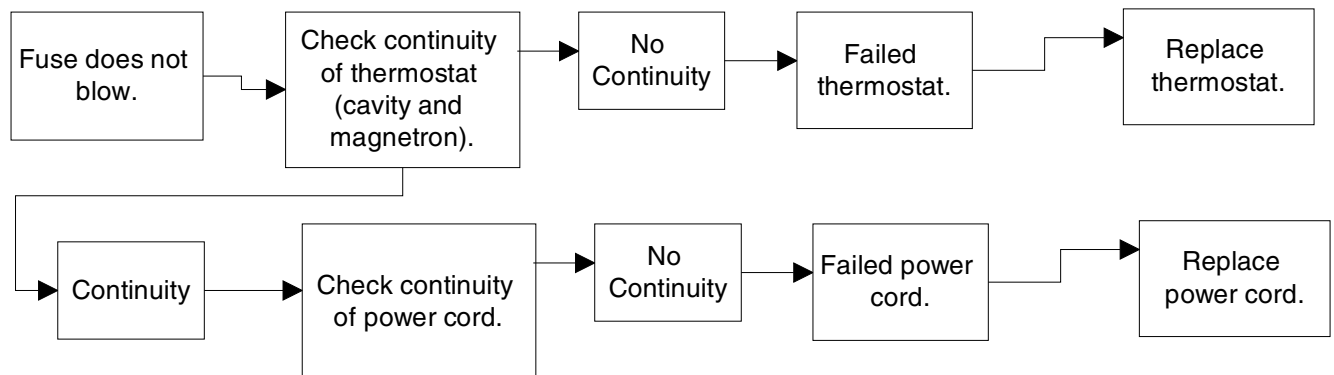
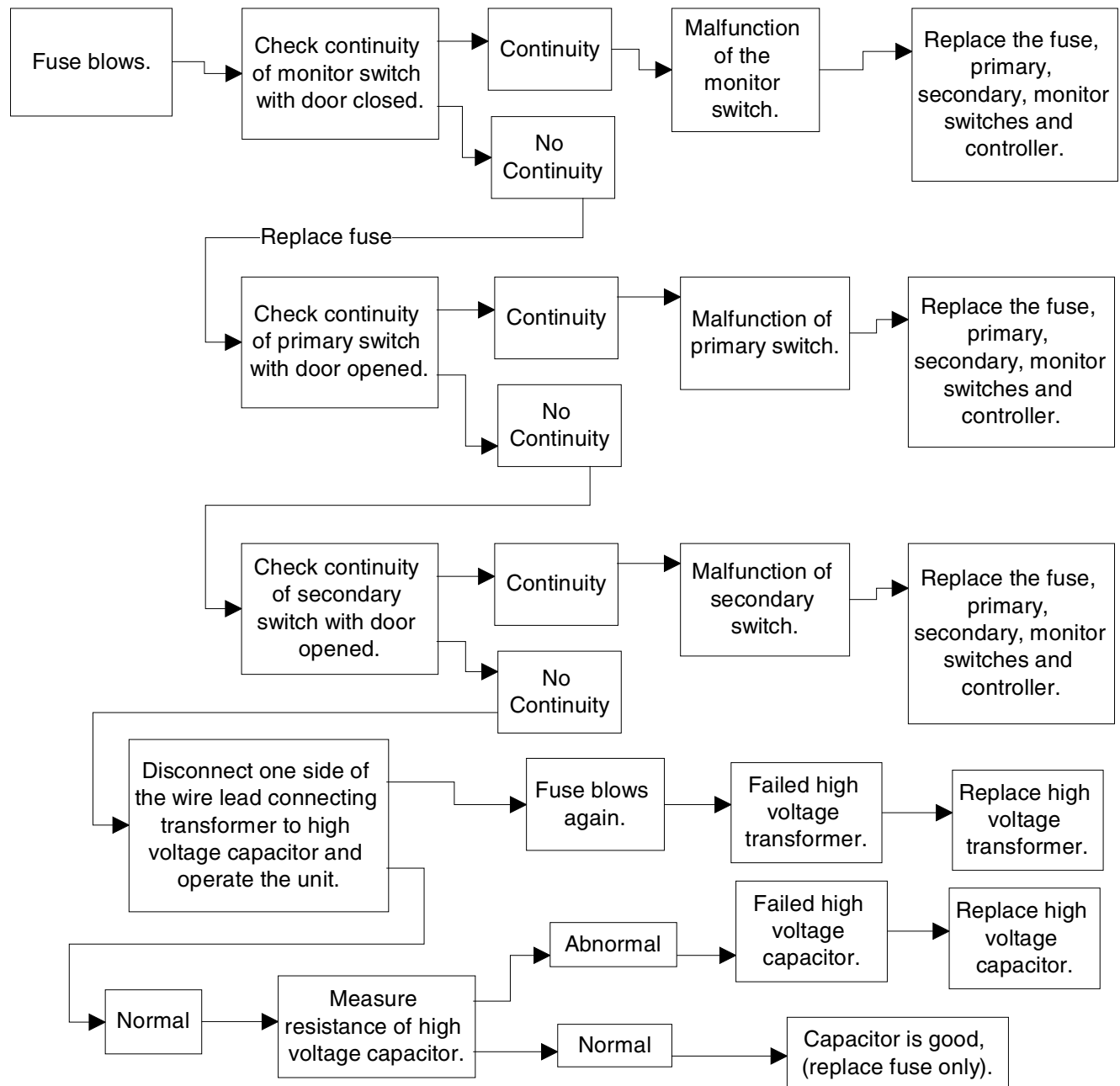

Troubleshooting Procedures (Electronic Models)

Trouble 3: Display shows all digits programmed, but does not start cooking when the START pad is pressed.

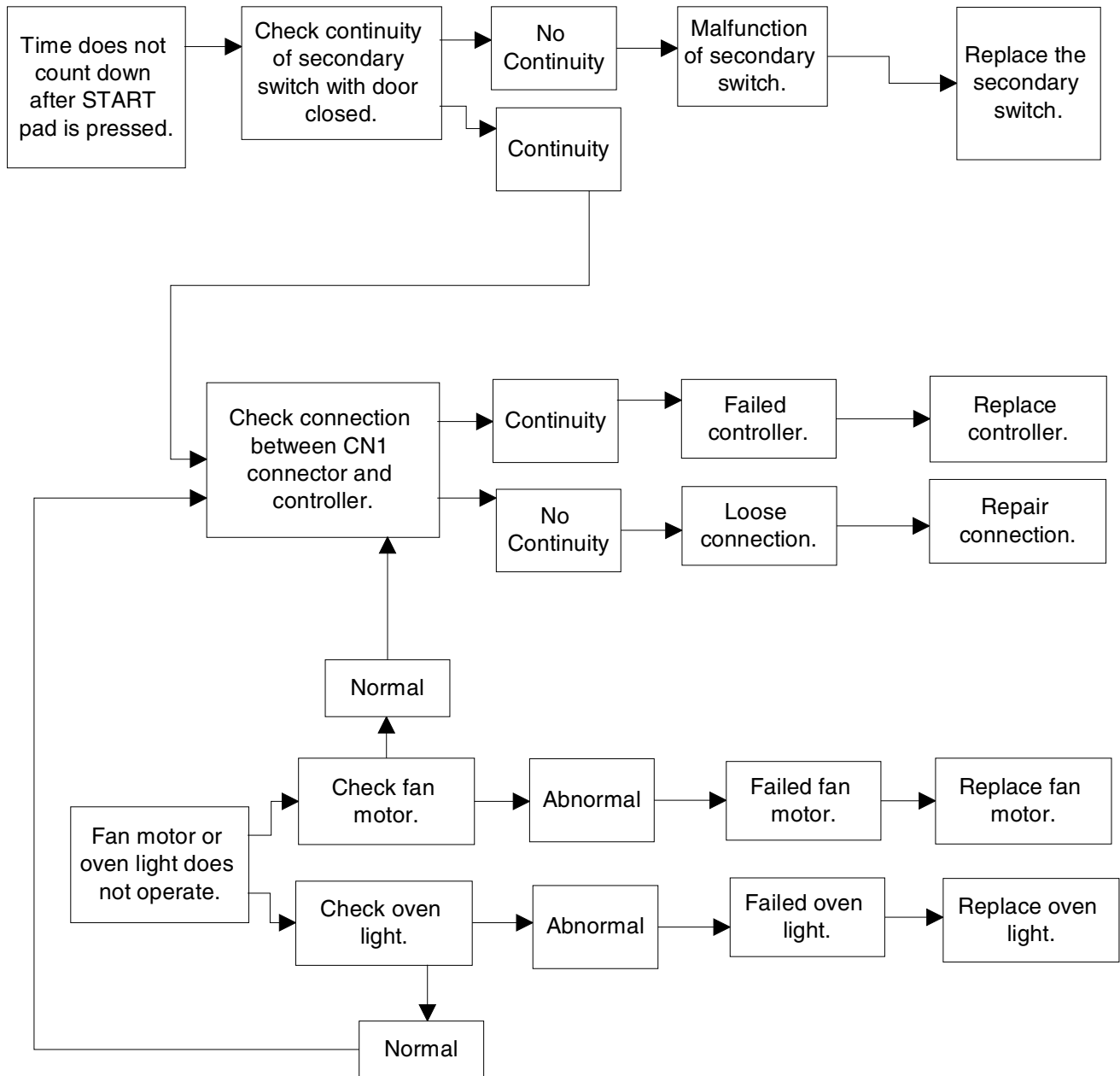

Troubleshooting Procedures (Electronic Models)

Trouble 4: Oven operates with little or no heat.

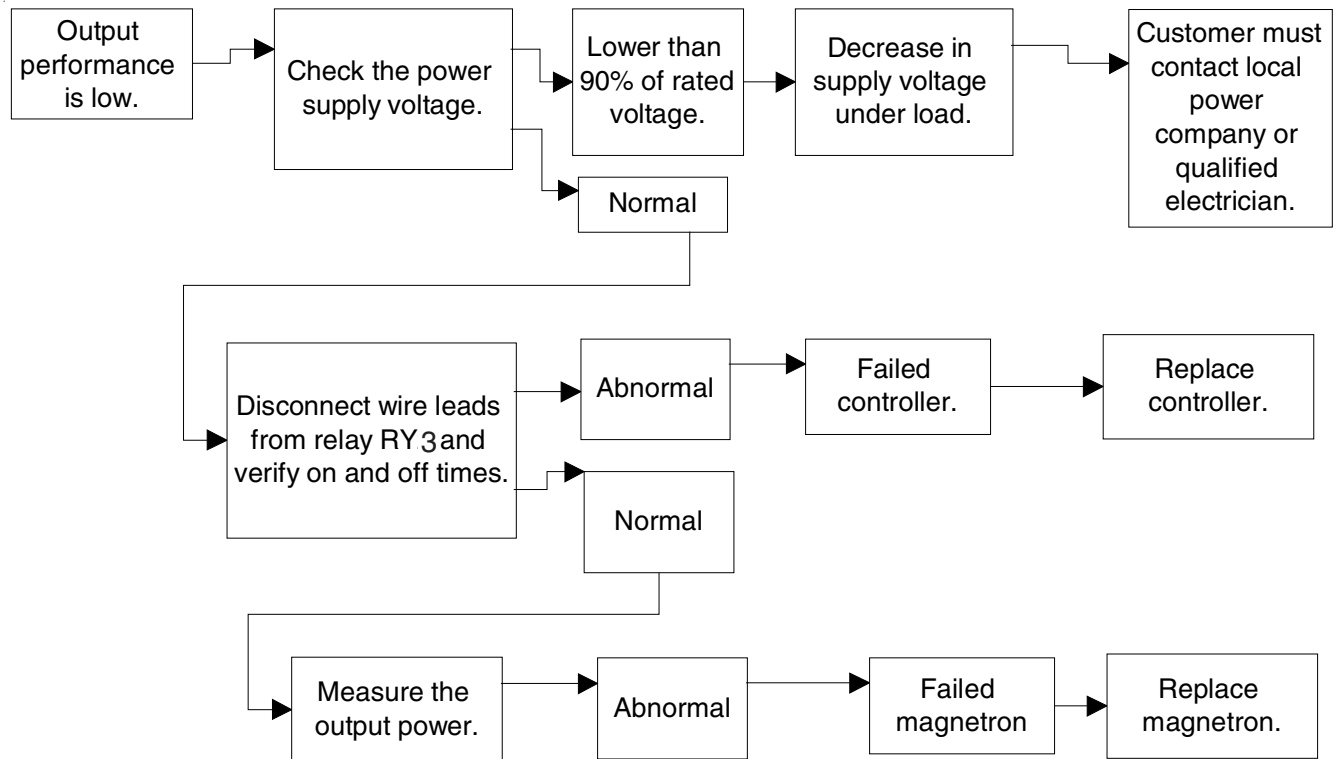

NOTE: Simple output power test can be conducted by heating one liter of water for 33 seconds. Refer to Power Test on page 24 of this manual.

Check for continuity of relay 3 with an ohmmeter.
(Remove wire leads from relay 3 and operate unit.)

<u>Power Level</u>	<u>Cycle ON</u>	<u>Cycle OFF</u>
1	3 sec.	9 sec.
2	4 sec.	8 sec.
3	5 sec.	7 sec.
4	6 sec.	6 sec.
5	7 sec.	5 sec.
6	8 sec.	4 sec.
7	9 sec.	3 sec.
8	10 sec.	2 sec.
9	11 sec.	1 sec.
10	12 sec.	0 sec.

Troubleshooting Procedures (Electronic Models)

Trouble 5: No microwave oscillation even when oven light and fan motor operate.

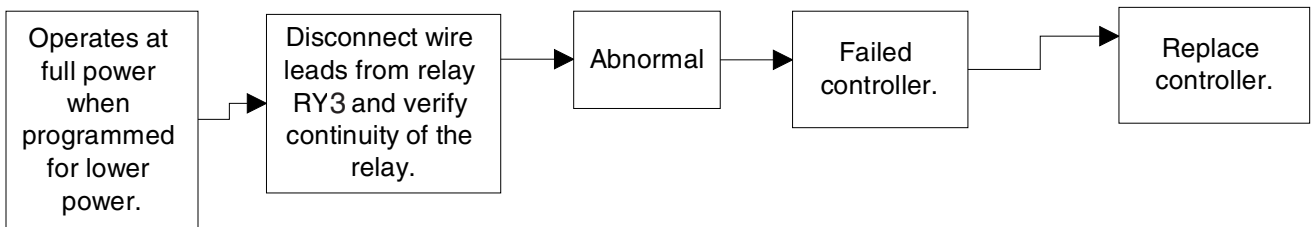
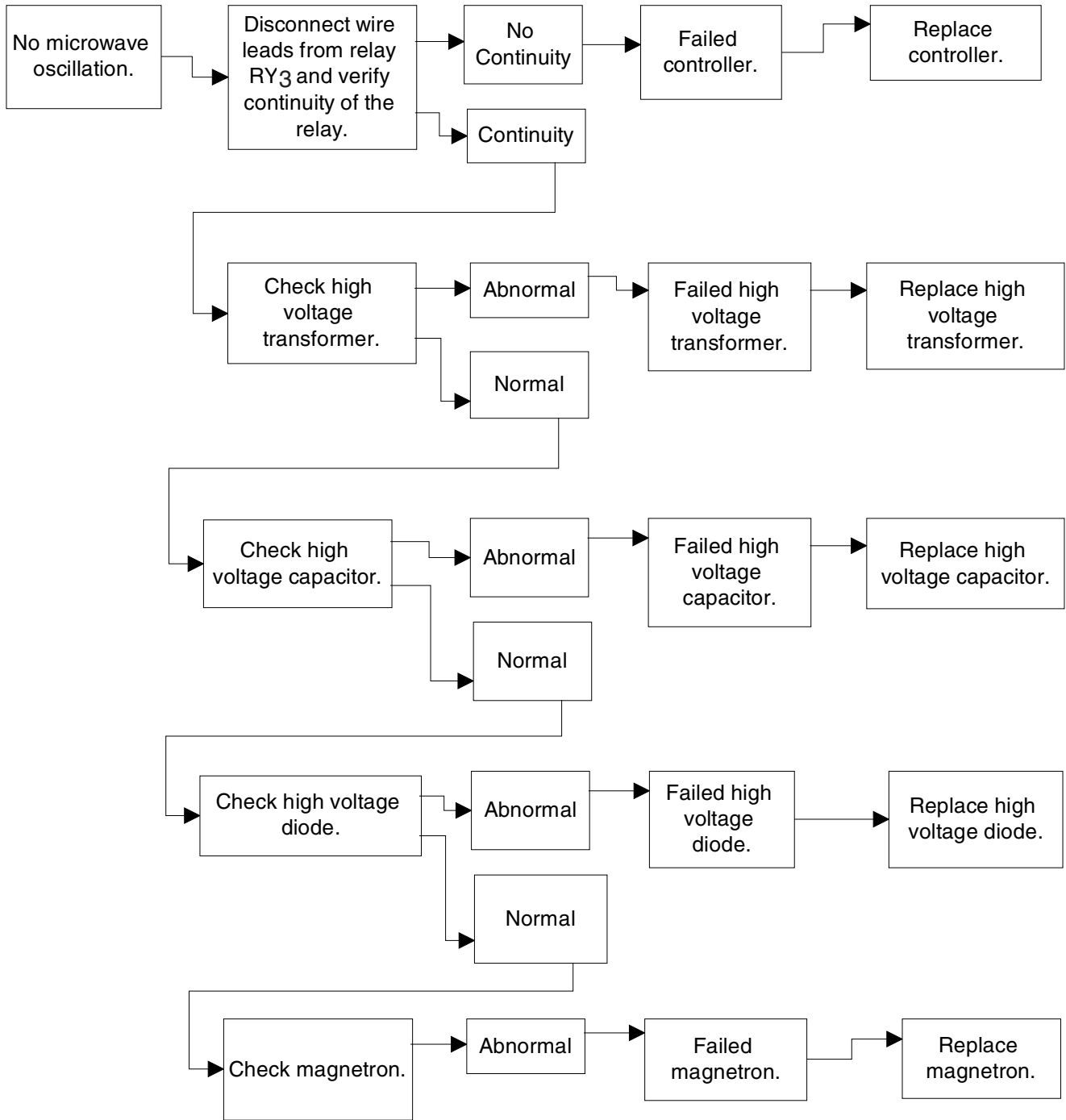

Service Information



WARNING

To avoid risk of electrical shock, personal injury, or death, disconnect power to oven and discharge capacitor before servicing, unless testing requires power.

Proper Handling of Magnetron Tubes



CAUTION

A magnetron tube, like a radio or television tube must be handled with a reasonable amount of care. When handling a tube, always handle by the housing only. Use caution not to touch or strike the ceramic portion at the top. The carton used to ship service replacement tubes is reusable.

Magnetron Failure Modes

Magnetron failures that have been identified are generally grouped into categories shown below.

1. Shorted

Air - This is a case where the tube has had the vacuum envelope destroyed and air has entered the tube. This will cause internal arcing and high secondary current if high voltage is applied.

R.F. Capacitors - May short to chassis. This condition will also cause loss of high voltage.

- 2. Open Heater (Filament)** - Can be determined by a ohmmeter when transformer leads are disconnected. Resistance is normally less than one ohm; filament does not short internally. Any tube removed should be checked since usage tends to make the filament more fragile. Later handling and shipping may open the filament and thereby mask the true failure mode when checked at the factory.
- 3. Low Power** - Caused by "wearout" of the emission characteristics of the directly heated cathode. Symptoms are: (1) tube current will take longer to get to operating point than a new tube (normally about 2 - 3 seconds), (2) tube current does not get high enough to cause the tube to oscillate with normal line voltage, (3) oven produces low power into a load, two-thirds or less than normal.
- 4. Physical Damage** - Caused by mishandling of magnetron tube.

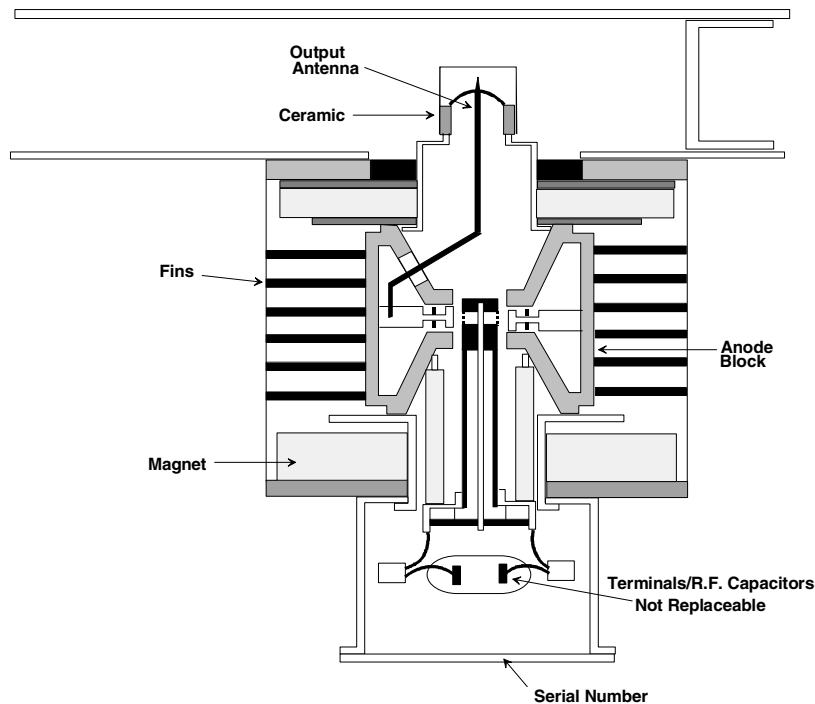

Microwave Leakage Testing



WARNING

To avoid risk of electrical shock, personal injury, or death, disconnect power to oven and discharge capacitor before servicing, unless testing requires power.



WARNING

Check for radiation leakage after servicing. Should the leakage be more than 4 mW/cm² inform Maytag immediately. After repairing or replacing any radiation safety device, keep a written record for future reference, as required by D.H.H.S. and HEW regulations. This requirement must be strictly observed. In addition, the leakage reading must be recorded on the service repair ticket while in the customer's home.

Equipment

- Electromagnetic radiation monitor
- 600 cc glass beaker or plastic power bowl

Procedure for Measuring Radiation Leakage

Note before measuring:

- Do not exceed meter full scale deflection. Leak monitor should initially be set to the highest scale.
 - To prevent false readings the test probe should be held by the grip portion of the handle only.
 - The scan speed is equal to one inch per antenna revolution or one inch per second if antenna speed is unknown.
 - Areas to be checked are all door seal areas and any venting parts.
 - Leakage with the outer panel removed ...4mW/cm² or less.
 - Leakage for fully assembled oven with door normally closed ...4 mW/cm² or less.
 - Leakage for a fully assembled oven (before the latch switch (primary) is interrupted) while pulling the door ... 4 mW/cm² or less.
1. Pour 275 cc ±15 cc (9 oz ±1/2 oz) of 20°C ± 5°C (68°F ± 9°F) water in a beaker which is graduated to 600 cc and place the beaker in the center of oven.
 2. Set the radiation monitor to 2450 MHz and use it following the manufacturer's recommended test procedure to assure correct results.
 3. While measuring the leakage, always use the two inch (5 cm) spacer supplied with the probe.
 4. Press the start pad or turn on the timer and with the magnetron oscillating, measure the leakage by holding the probe perpendicular to the surface being measured.

Measurement with the Outer Panel Removed



WARNING

Avoid contacting any high voltage components.

Whenever you replace the magnetron, measure for radiation leakage before the outer panel is installed and after all necessary components are replaced or adjusted. Special care should be taken in measuring around the magnetron.

Measurement with a Fully Assembled Oven

After all components including the outer panel are fully assembled, measure for radiation leakage around the door periphery, the door viewing window, the exhaust opening, and air inlet openings.

Record Keeping and Notification After Measurement

1. After any adjustment or repair to a microwave oven, a leakage reading must be taken. Record this leakage reading on the repair ticket even if it is zero.
2. A copy of the repair ticket and the microwave leakage reading should be kept by the repair facility.

Troubleshooting



WARNING

To avoid risk of electrical shock, personal injury, or death, disconnect power to oven and discharge capacitor before servicing, unless testing requires power.

Operating Instructions for the Holaday HI1501, HI1510, HI1710, and HI1801

Purpose of these monitors is to check radiation leakage around microwave oven door or other places where radiation could possibly occur.

Instrument measures radiation leakage in milliwatts per square centimeters (mW/cm²). Probe should be used with the 2" (5 cm) cone spacer. Water load of 275 cc. (approximately 1 1/3 cup), is to be placed in the oven and used as a load during leakage tests.

Operate the instrument on its internal 9 Volt battery power supply. "Range" switch is used on low and high while using test probe. On an oven with an unknown leakage, use high scale then switch to low scale and test for low leakage. "Bat Test" switch is used to check the battery and probe on the Holaday Instruments. If either is faulty, meter needle will not read above "Test Minimum" or battery mark on meter. Holaday Instrument has a probe test switch position. Meter needle must indicate in the "OK probe test" portion of the scale when in this position. Zero control is used to zero the needle. "ON-OFF" switch provides a means of turning the operating voltage on or off. "Range Multiplier" switch provides a means of selection either 0-2 or 0-10 and 0-100 on the Holaday Instruments sensitivity ranges.

Test probe must be held by the grip portion of the handle, otherwise a false reading may result if operators hand is between the handle and probe.

If oven is likely to have a large amount of leakage, approach oven slowly with the probe, while observing meter. This is achieved by holding the probe two or three feet from oven surface or gap between door and oven body while observing meter. When high leakage is expected, do not move probe horizontally along the oven surface. This could cause possible probe burn-out. Greatest leakage is generally found at the corners. After maximum leakage is established to be within the meter scale range, then probe may be moved horizontally around the door surface.





Hold probe perpendicular to cabinet door. Place cone of probe on the door and/or cabinet door seam and move along the seam. If leakage of the oven is unknown, move probe slowly. Proceed with care in order not to exceed a full scale reading of meter. When testing near a corner or access area of door, keep probe perpendicular to the areas making sure probe end at the base of the cone does not get closer than 2" (5cm) to any metal. If it does, an erroneous reading may result.

Always use the 2" (5cm) spacer with probe. Also, always proceed carefully in areas of high leakage or probe can be accidentally burned-out. Rotating antenna causes high peaks of energy. Although meter has averaging capabilities, probe will react instantaneously to peak power changes which will cause burn-out.

Testing Procedures

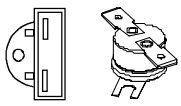
⚠ WARNING

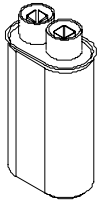
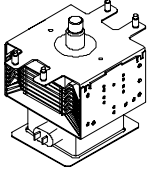
To avoid risk of electrical shock, personal injury or death; disconnect power to oven and discharge capacitor before servicing, unless testing requires power.

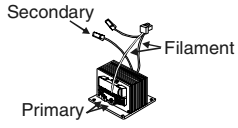
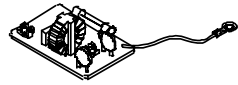
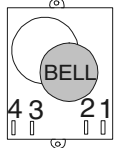
Illustration	Component	Testing	Results
	Thermal cutout	Disconnect all wires from TCO. Measure resistance across terminals. Cavity TCO..... Magnetron TCO.....	Closed at 32°F (0°C) and Opens at 230°F (110°C) Closed at 140°F (60°C) and Opens at 320°F (160°C)
	Diode	Discharge Capacitor Remove diode lead from capacitor and connect ohmmeter. Reverse leads for second test.	Infinite resistance should be measured in one direction and 50KΩ or more in the opposite direction. NOTE: Ohmmeter must contain a battery of 6 volts minimum.
	Circuit Protector	Discharge Capacitor Remove diode lead from capacitor and connect ohmmeter. Reverse leads for second test.	Infinite resistance should be measured in one direction and 50KΩ or more in the opposite direction. NOTE: Ohmmeter must contain a battery of 6 volts minimum.
	Capacitor	Discharge Capacitor Remove wires from capacitor terminals and connect ohmmeter, set on highest resistance scale to terminals. Also check between each terminal and capacitor case.	Between Terminals: Meter should momentarily deflect towards zero then return to over 5 MΩ. If no deflection occurs, or if continuous deflection occurs, replace capacitor. Terminal to Case: Infinite resistance
	Magnetron	Discharge Capacitor Remove wires from magnetron and connect ohmmeter to terminals. Also check between each terminal and ground.	Between Terminals: Less than 1 Ω Each terminal to ground measures Infinite resistance. Note: This test is not conclusive. If oven does not heat and all other components test good replace the magnetron and retest.
	Blower motor	Remove all wires from motor. Measure resistance across coil	Approximately 72 – 82 Ω
	Stirrer motor	Remove all wires from motor. Measure resistance across terminals	Approximately 12.8 – 13.5 KΩ
	Transformer	Discharge Capacitor Remove all wires from terminals. Measure resistance from: Primary Filament..... Secondary to Ground screw on transformer stack.....	Less than <1 Ω Less than <1 Ω Approximately 110 – 125 Ω
	Noise filter board	Power In terminals..... Power Out terminals.....	230/240 VAC 230/240 VAC If no power in, check power outlet. If no power out, check fuses.
	6 minute timer	Remove leads from timer contact terminals. Measure resistance of following terminals: 1 to 2—Timer in OFF position..... 1 to 2—Timer in ON position..... 3 to 4—Timer in OFF or ON position	If timer does not indicate readings below, replace timer. Infinite Ω Approximately <1 Ω Approximately 11 KΩ (timer motor)

Testing Procedures



WARNING

To avoid risk of electrical shock, personal injury or death; disconnect power to oven and discharge capacitor before servicing, unless testing requires power.

Illustration	Component	Testing	Results
	Interlock switch assembly 	Disconnect wires to switch. With door open measure resistance from: Monitor - Terminal 3 - 4..... Primary - Terminal 1 - 2..... Secondary - Terminal 5 - 6..... With door closed measure resistance from: Monitor - Terminal 3 - 4..... Primary - Terminal 1 - 2..... Secondary - Terminal 5 - 6..... After verifying or replacing the module, reconnect wires to switch and check operation of monitor circuit before operating the oven.	Indicates continuity Infinite Ω Infinite Ω Infinite Ω Indicates continuity Indicates continuity
	Lamp receptacle	Test continuity of receptacle terminals.	Indicates continuity with bulb installed.
	Wire Harness	Test continuity of wires	Indicates continuity

Electronic Control Panel			
	Service Test Mode:	Open door, Press and Hold pad 3 for 5 seconds to enter service test mode. Press Pad 1 Press Pad 2 Press Pad 3 Press Pad 4 Press Pad 5 Press Pad 6 Press Pad 7 Press Pad 8 Press Pad 9 Press Pad 0 Stop/Reset Pad	SERVICE appears in the display Indicates number of hours magnetron has been turned on Indicates number of times magnetron tube has been turned on and off Indicates number of door cycles CLEAR (Press START pad to reset service data.) Indicates amperage N/A N/A N/A N/A N/A Exit Service Test Mode
	Error codes:	E-08 E-09 E-10	Replace Control Board Replace Control Board Shorted or Open Keypad – Test and replace if necessary

Electronic Dial Control Panel			
	Service Test Mode:	Open door, Press and Hold Hidden Pad 2 for 5 seconds to enter service test mode. Press Hidden Pad 2 Press Hidden Pad 2 again Press Hidden Pad 2 again Press Hidden Pad 2 again Press Hidden Pad 2 again Press Hidden Pad 2 again	Enters into Service Test Mode Indicates number of magnetron hours Indicates tube cycles Indicates number of door cycles Indicates amperage Turn dial to Clear Info – When dial is rotated display indicates CLEARED INFO

Testing Procedures



WARNING

To avoid risk of electrical shock, personal injury or death; disconnect power to oven and discharge capacitor before servicing, unless testing requires power.

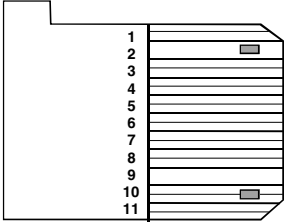
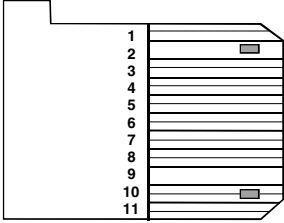
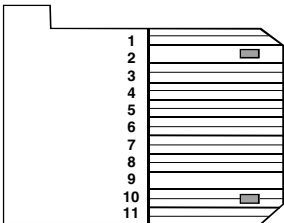
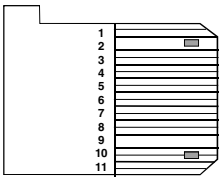
Illustration	Component	Testing	Results		
Electronic Control RS511P URS511P	Keyboard assembly 	Continuity is indicated as 100 Ω and below.	Pad 0 1 2 3 4 5 6 7 8 9 HOLD (0%) DEFROST (20%) MEDIUM (50%) MED-HI (70%) TIME ENTRY STOP/RESET START	Trace 1 & 8 2 & 8 3 & 8 4 & 8 5 & 8 6 & 8 7 & 8 1 & 9 2 & 9 3 & 8 1 & 10 2 & 10 3 & 10 4 & 10 5 & 10 6 & 10 7 & 10	Measurement Continuity Continuity Continuity Continuity Continuity Continuity Continuity Continuity Continuity Continuity Continuity Continuity Continuity Continuity Continuity Continuity Continuity Continuity
Electronic Control DFS11EA RCS511A UFS11EA URCS511A	Keyboard assembly 	Continuity is indicated as 100 Ω and below.	Pad 0 1 2 3 4 5 6 7 8 9 QTY 2X HOLD (0%) DEFROST (20%) MEDIUM (50%) MED-HI (70%) TIME ENTRY STOP/RESET START	Trace 1 & 8 2 & 8 3 & 8 4 & 8 5 & 8 6 & 8 7 & 8 1 & 9 2 & 9 3 & 8 7 & 9 1 & 10 2 & 10 3 & 10 4 & 10 5 & 10 6 & 10 7 & 10	Measurement Continuity Continuity Continuity Continuity Continuity Continuity Continuity Continuity Continuity Continuity Continuity Continuity Continuity Continuity Continuity Continuity Continuity Continuity
Electronic Control DES11EA US11EA	Keyboard assembly 	Continuity is indicated as 100 Ω and below.	Pad 0 1 2 3 4 5 6 7 8 9 TIME ENTRY STOP/RESET START	Trace 1 & 8 2 & 8 3 & 8 4 & 8 5 & 8 6 & 8 7 & 8 1 & 9 2 & 9 3 & 8 5 & 10 6 & 10 7 & 10	Measurement Continuity Continuity Continuity Continuity Continuity Continuity Continuity Continuity Continuity Continuity Continuity Continuity Continuity
Dial Control DECS11MA RCS511MB UCS11MA URS511MB	Keyboard assembly 	Continuity is indicated as 100 Ω and below.	Pad 30 QUICK SET HIDDEN #1 HIDDEN #2 DEFROST (20%) MEDIUM (50%) MED-HI (70%) TIME ENTRY STOP/RESET START	Trace 1 & 8 2 & 8 3 & 8 2 & 10 3 & 10 4 & 10 5 & 10 6 & 10 7 & 10	Measurement Continuity Continuity Continuity Continuity Continuity Continuity Continuity Continuity Continuity Continuity

Testing Procedures



WARNING

To avoid risk of electrical shock, personal injury or death; disconnect power to oven and discharge capacitor before servicing, unless testing requires power.

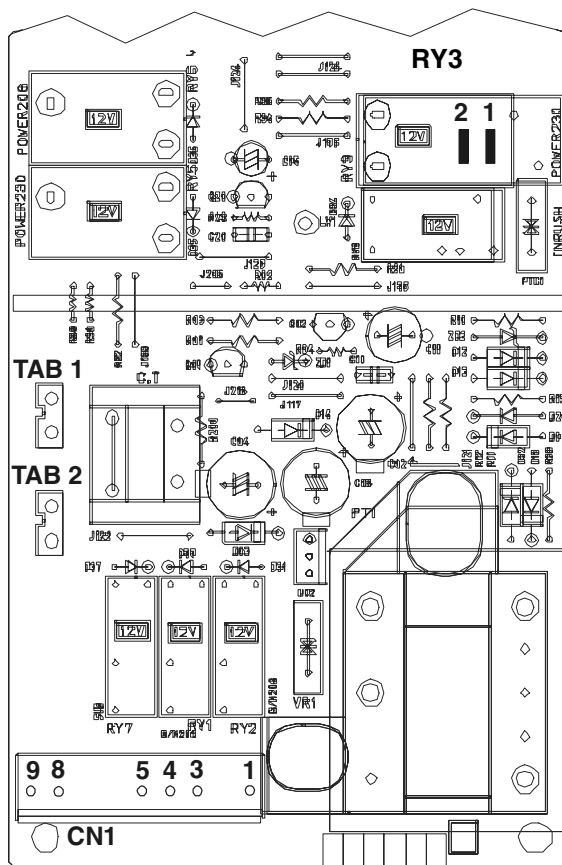

Function	Test Set-Up / Condition	Meter Setting	Probe Placement	Results
Control power transformer input	All Conditions	Volts	CN1 – Pin 3 to Pin 1 (White to Black)	230/240 VAC
Current transformer input	All Conditions	Volts	Tab 1 to Power Cord Blue (Neutral)	230/240VAC
Current transformer output	All Conditions	Volts	Tab 2 to Power Cord Blue (Neutral)	230/240VAC
Oven light relay RY7	Standby..... Ready..... Cook	Volts Volts Volts	CN1 – Pin 4 to Pin 1 (Yellow to Black).. CN1 – Pin 4 to Pin 1 CN1 – Pin 4 to Pin 1	0 VAC 230/240VAC 230/240VAC
Blower / Stirrer motor relay RY1	Standby..... Ready..... Cook	Volts Volts Volts	CN1 – Pin 5 to Pin 3 (Brown to White) . CN1 – Pin 5 to Pin 3 CN1 – Pin 5 to Pin 3	230/240VAC 0 VAC 0 VAC
Secondary Interlock Switch	Door Closed..... Door Opened	Ohms Ohms	CN1 – Pin 8 to Pin 9 (Pink to Green) CN1 – Pin 8 to Pin 9	< 1 ? Infinite
Cook relay RY3	Standby..... Ready..... Cook	Volts Volts Volts	Relay 3 – Pin 1 to Pin 2..... Relay 3 – Pin 1 to Pin 2..... Relay 3 – Pin 1 to Pin 2.....	230/240VAC 230/240VAC 0 VAC

Testing Procedures



WARNING

To avoid risk of electrical shock, personal injury or death; disconnect power to oven and discharge capacitor before servicing, unless testing requires power.

Power Test

All Amana and Menumaster microwave oven power outputs are rated using the IEC705 standards. Using the IEC705 test method requires precision measurements and equipment that is not practical to be performed in the field. Using the test shown below will indicate if the oven performance is satisfactory.

Test equipment required:

- 1000 ml test container and thermometer (Amana power test kit R0157397 Fahrenheit / Menumaster power test kit M95D5 Celsius).
- Digital watch / watch with a second hand for use on ovens with electromechanical timers.

Important Notes:

- Low line voltage will cause low temperature rise / power output.
- Ovens must be on a dedicated circuit, properly grounded, and polarized. Other equipment on the same circuit may cause a low temperature rise / power output.
- This test and results are not a true IEC705 test procedure and are only intended to provide servicers with an easy means of determining if the microwave oven cooking output is correct.

Procedure

1. Fill the test container to the 1000 ml line with cool tap water.

NOTE: Water temperature should be approximately 60°F / 16°C

2. Using the thermometer, stir water for five to ten seconds; measure, and record the temperature (T1).
3. Place test container of water in the center of oven cavity and close door.
4. Heat the water for a 33-second full power cycle.

NOTE: Use a digital watch or a watch with a second hand for ovens with electromechanical timers.

1. At end of the cycle, remove test container. Using the thermometer, stir water for five to ten seconds and record temperature (T2).
2. Subtract the starting water temperature (T1), from the ending water temperature (T2) to obtain the temperature rise (ΔT).
3. If the temperature rise (ΔT) meets or exceeds the minimum, the test is complete. If the temperature rise (ΔT) fails to meet the minimum temperature rise, test the line voltage to verify it is correct. Then repeat steps 1-6 making sure to change the water. If the temperature rise (ΔT) fails to meet the minimum temperature rise again the oven will require service.

Minimum Temperature Rise at Thirty -Three (33) Seconds Run Time

ΔT (°F)	Cooking Power Output	ΔT (°F)	Cooking Power Output	ΔT (°C)	Cooking Power Output	ΔT (°C)	Cooking Power Output
10.....	1000	20.....	2000	5	1000	11.....	2000
11.....	1100	21.....	2100	5.5	1100	11.5.....	2100
12.....	1200	22.....	2200	6.5	1200	12.....	2200
14.....	1400	24.....	2400	7.5	1400	13.....	2400
17.....	1700	25.....	2500	9.5	1700	13.5.....	2500
18.....	1800	27.....	2700	10	1800	15.....	2700
19.....	1900	30.....	3000	10.5	1900	16.5.....	3000

Disassembly Procedures

WARNING

To avoid the risk of electrical shock, personal injury, or death, disconnect power to oven and discharge the capacitors before following any disassembly procedure.

High voltage is present at the high voltage terminal of the high voltage transformer during any cooking cycle.

It is neither necessary or advisable to attempt measurement of the high voltage.

Before touching any oven components or wiring, always unplug the oven from its power source and discharge capacitor.

Disconnecting Wire Terminals

All wire terminals are locking-type terminals. Proceed as follows to disconnect wire terminals:

Insulated terminals:

Grasp insulator pod and pull back.

DO NOT PULL ON WIRE.

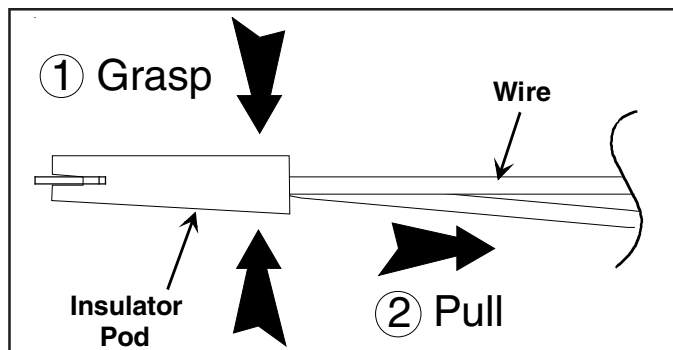

Non-insulated terminals:

Use a small blade screwdriver to depress locking-tab and pull on terminal.

DO NOT PULL ON WIRE.

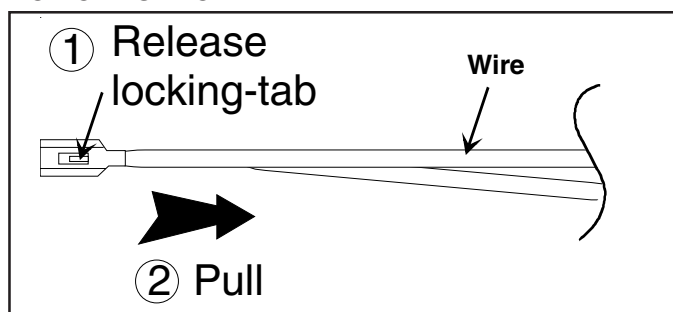

Outer Case

1. Disconnect power to oven.
2. Remove screws securing outer case to unit.
3. Slide outer case towards rear of unit.
4. Reverse procedure to reassemble.

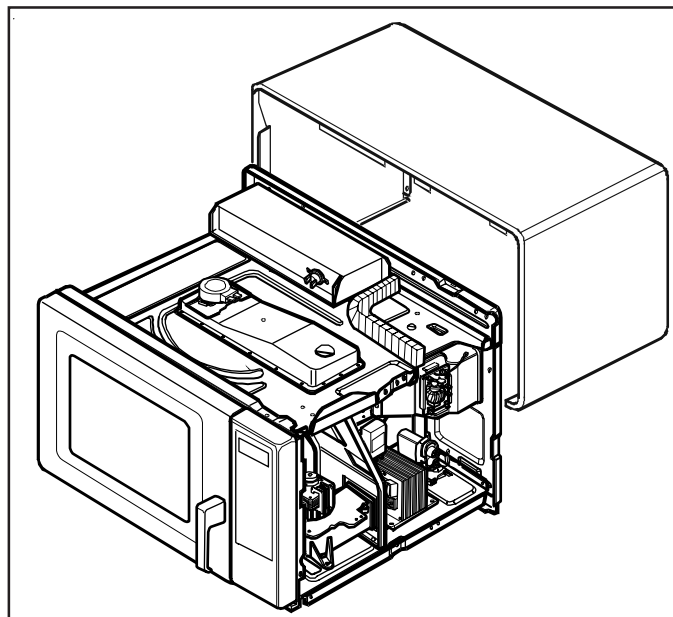

CAUTION

During disassembly some foam gaskets may require removal. These components must be replaced for proper circulation of air over the components and through the oven cavity.

Disassembly Procedures



WARNING

To avoid the risk of electrical shock, personal injury, or death, disconnect power to oven and discharge the capacitors before following any disassembly procedure.

Door Assembly



CAUTION

A microwave leakage test must be performed anytime a door assembly is removed, replaced, disassembled, or adjusted for any reason.

Door Removal

1. Disconnect power to oven.
2. Open oven door, remove top hinge cap, and slowly lift door to disengage the hinge pins at top and bottom.

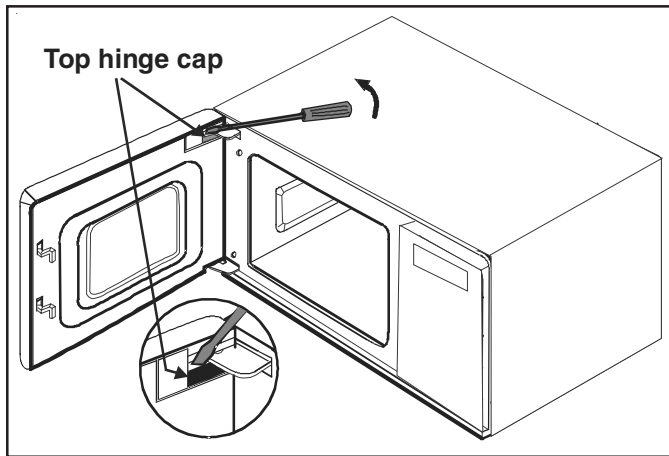

3. To reinstall door, place top pin into slot first, then align bottom pin.
4. Reinstall top hinge cap.

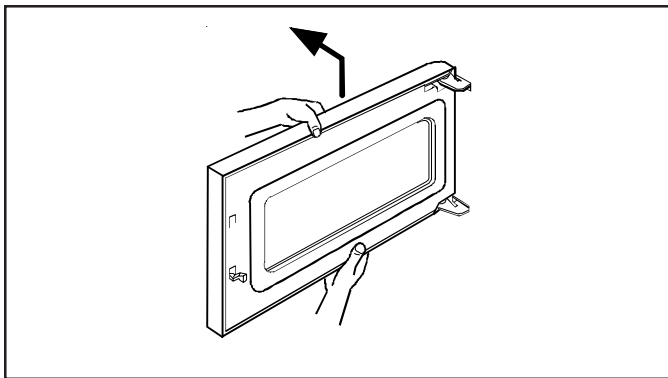

Door Disassembly

1. Disconnect power to oven.
2. Remove oven door, (see "Door Removal").
3. Begin at the bottom of the door near hinge, insert flat blade screwdriver between choke cover and outer door panel. Gently pry upward on choke cover to release tabs. Work in clockwise direction to remove choke cover.



CAUTION

To avoid property damage, care must be taken when prying choke cover from oven door.

4. Remove screw securing door handle to latch assembly.
5. Slide latch assembly downward and pull away from door frame to release.
6. Remove screws securing choke assembly to outer door panel.

NOTE: When disassembling door, use caution to prevent deformation of slats on door frame/choke assembly.

7. Begin at hinge side of door near bottom, insert flat blade screwdriver between door frame/choke assembly and outer door panel. Gently pry outer door panel away from door frame to release tabs. Work in clockwise direction to remove door frame.
8. Remove spring from hinge assembly.
9. Remove screws securing hinge assembly to choke assembly.
10. Reassemble in reverse order.

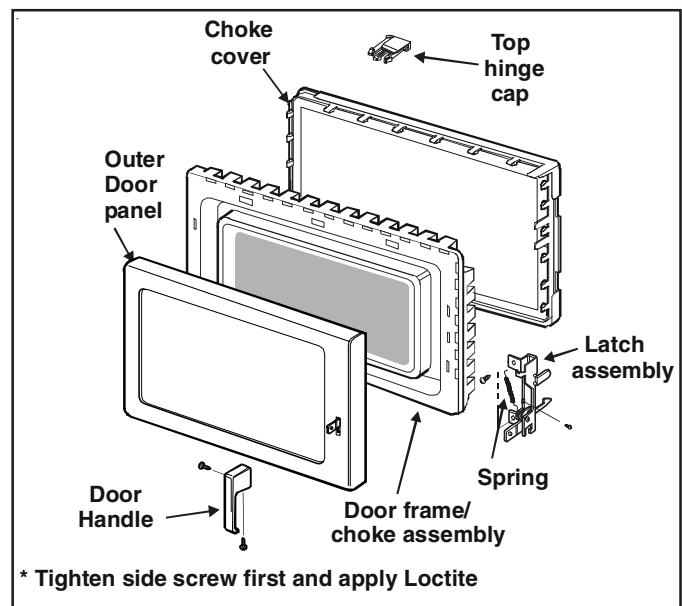

Disassembly Procedures

WARNING

To avoid the risk of electrical shock, personal injury, or death, disconnect power to oven and discharge the capacitors before following any disassembly procedure.

CAUTION

A microwave leakage test must be performed anytime a door assembly is removed, replaced, disassembly, or adjusted for any reason.

Control Panel Removal

1. Disconnect power to oven and remove outer case, (see "Outer Case" procedure).
2. Disconnect and label wires from controller/timer.
3. Open oven door.
4. Remove screw securing top of control panel to cavity. Lift control panel up and out to release tabs.

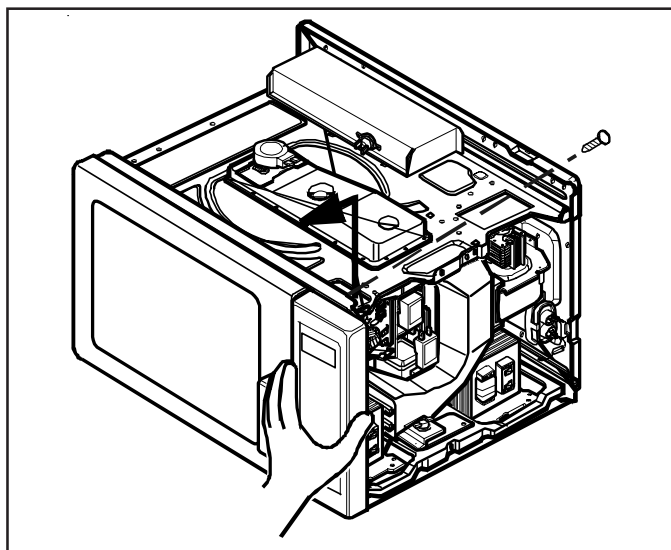

5. Replace component and reverse procedure to reassemble.

Interlock Switches

Primary switch is operated by bottom latch arm.

Interlock Switch Removal

1. Disconnect power to oven and remove outer case, (see "Outer Case" procedure).
2. Remove control panel, (see "Control Panel" section).
3. Test interlock switches before removing, (see testing procedures).
4. Disconnect and label wire connections.
5. Remove mounting screws securing interlock switch to unit chassis.
6. Replace component and reverse procedure to reassemble.

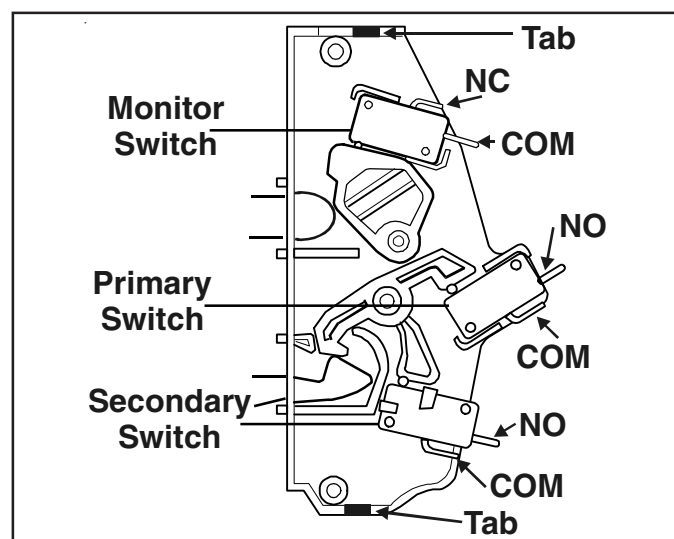

NOTE: After repairing the door or the interlock system, it is necessary to check the switch continuity before operating the oven.

CAUTION

Before replacing a blown monitor fuse, test the primary interlock switch, secondary interlock switch, monitor switch, and power relay contacts for proper operation. If the monitor fuse is blown by a failed switch operation, all switches and controller must be replaced.

Disassembly Procedures



WARNING

To avoid the risk of electrical shock, personal injury, or death, disconnect power to oven and discharge the capacitors before following any disassembly procedure.

Adjusting Interlocks

The interlock monitor, primary, and secondary switches act as a final safety switch, protecting the operator from microwave energy. After adjusting the interlock switch assembly, verify wires are correctly connected.

For door fit and switch operation, switch bracket is adjustable.

1. Disconnect power to oven and remove outer case, (see "Outer Case" procedure).
2. Loosen switch bracket mounting screws.
3. Close oven door, move switch bracket toward rear of oven until door gap is less than $\frac{1}{64}$ -inch (0.5 mm).
4. Hold switch bracket securely for proper switch operation and door fit, retighten screws.
5. Open oven door slowly, watching the switches. Verify switches release in the following order.
 - Primary interlock switch
 - Secondary interlock switch
 - Interlock monitor switch

NOTE: Adjust the switch bracket until all switches operate in proper sequence.

6. Close the oven door slowly, watching the switches. Verify switches activate in the following order.
 - Interlock monitor switch
 - Secondary interlock switch
 - Primary interlock switch
7. When proper switch sequence has been achieved, tighten the switch bracket securely.



CAUTION

A microwave leakage test must be performed anytime a door assembly is removed, replaced, disassembled, or adjustment of switch bracket is performed.

High Voltage Capacitor

High voltage capacitor should always be discharged by shorting a terminal to a chassis ground. The capacitor has a internal "shunt" resistor, but the mechanical discharge should always be performed to avoid personal injury.

High Voltage Capacitor Removal

1. Disconnect power to oven and remove outer case, (see "Outer Case" procedure).
2. Discharge high voltage capacitor.
3. Remove and label wire leads from capacitor terminals.
4. Remove screw securing capacitor strap to top of cavity.
5. Slide capacitor out of capacitor strap and remove capacitor.
6. Replace capacitor and reverse procedure to reassemble.

NOTE: When replacing H.V. components, route H.V. wires at least $\frac{1}{4}$ " / 6 mm from all grounded surfaces to prevent arcing.

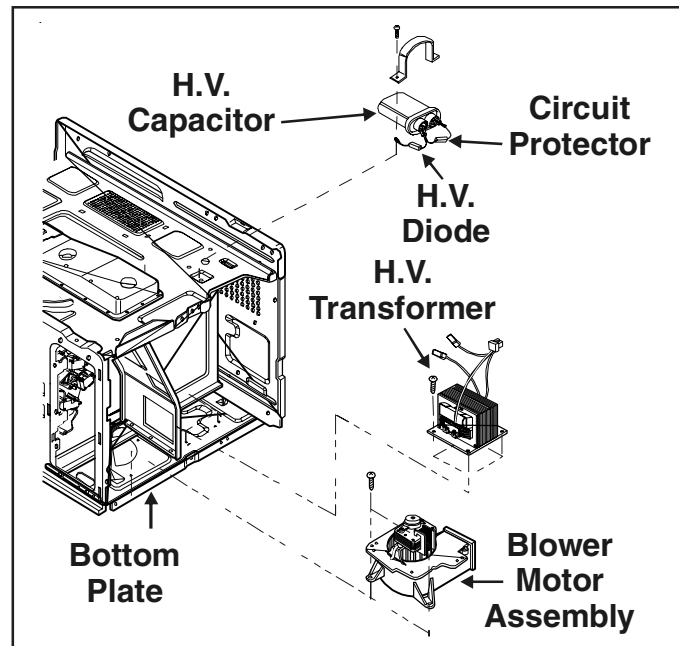

Diode/Circuit Protector

1. Disconnect power to oven and remove outer case, (see "Outer Case" procedure).
2. Discharge high voltage capacitor, (see "High Voltage Capacitor" section).
3. Disconnect diode from high voltage capacitor and remove screw securing diode to ground.
4. Replace diode and reverse procedure to reassemble.

Disassembly Procedures

WARNING

To avoid the risk of electrical shock, personal injury, or death, disconnect power to oven and discharge the capacitors before following any disassembly procedure.

Transformer

1. Disconnect power to oven and remove outer case, (see "Outer Case" procedure).
2. Discharge high voltage capacitor, (see "High Voltage Capacitor" section).
3. Disconnect and label wire leads from transformer.
4. Remove screws securing transformer and remove.
5. Replace transformer and reverse procedure to reassemble.

Fuse / Fuse Block / Filter Assembly

1. Disconnect power to oven and remove outer case, (see "Outer Case" section).
2. Disconnect and label wires.
3. Remove fuse to gain access to screws securing assembly.
4. Carefully lift tab to release assembly from locating pin.
5. Replace component(s) and reverse procedure to reassemble.

CAUTION

Before replacing a blown monitor fuse, test the primary interlock switch, secondary interlock switch, monitor switch, and power relay contacts for proper operation. If the monitor fuse is blown by a failed switch operation, all switches and controller must be replaced.

Magnetron

Magnetron is located on the side of the cavity.

1. Disconnect power to oven and remove outer case, (see "Outer Case" section).
2. Discharge high voltage capacitor, (see "High Voltage Capacitor" section).
3. Remove terminal plug from filament terminals.
4. Remove screws securing magnetron cutout bracket to magnetron.
5. Remove screws securing magnetron to the wave guide.

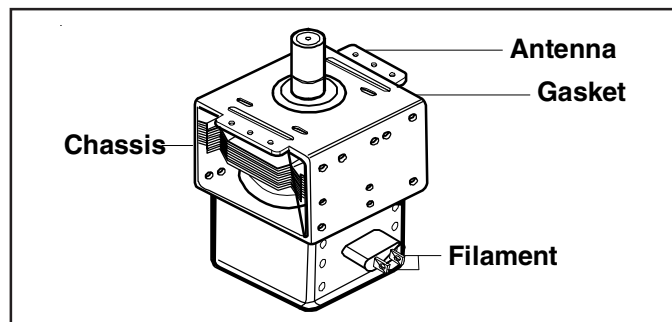

6. Replace magnetron and reverse procedure to reassemble.

NOTE: When replacing magnetron, make sure gasket is in correct position and in good condition.

CAUTION

During replacement of magnetron, be certain the R.F. anode gasket is in place around the anode stud.

WARNING

A microwave leakage test must be performed anytime a magnetron assembly is removed, replaced, disassembled, or adjusted for any reason.

Disassembly Procedures



WARNING

To avoid the risk of electrical shock, personal injury, or death, disconnect power to oven and discharge the capacitors before following any disassembly procedure.

Blower Motor or Wheel

1. Disconnect power to oven and remove outer case, (see "Outer Case" procedure).
2. Remove outer case.
3. Disconnect wiring from blower motor.
4. Remove screws securing blower motor assembly to chassis.
5. Slide blower motor assembly from partition and lift blower motor assembly from unit.
6. Replace component and reverse procedure to reassemble.

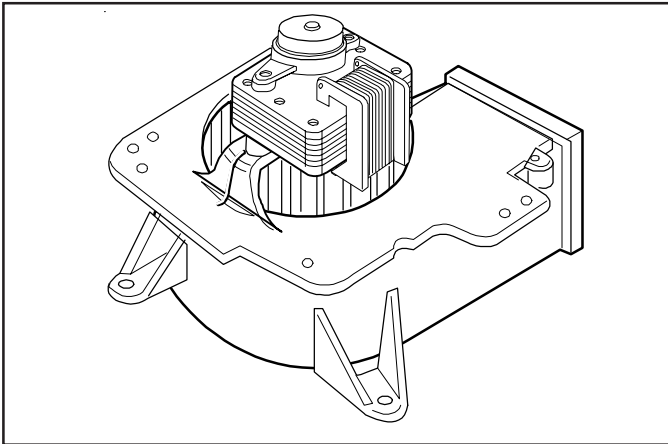

Splatter Shield

NOTE: Be careful not to bend antenna when removing splatter shield. Shield snaps into a lip in front of the oven and three slots in the back.

1. Place your thumbs in the two indentations in front of the shield.
2. Press lightly towards the back and carefully lower shield away from antenna.
3. Pull shield out of the back slots and out of the oven.

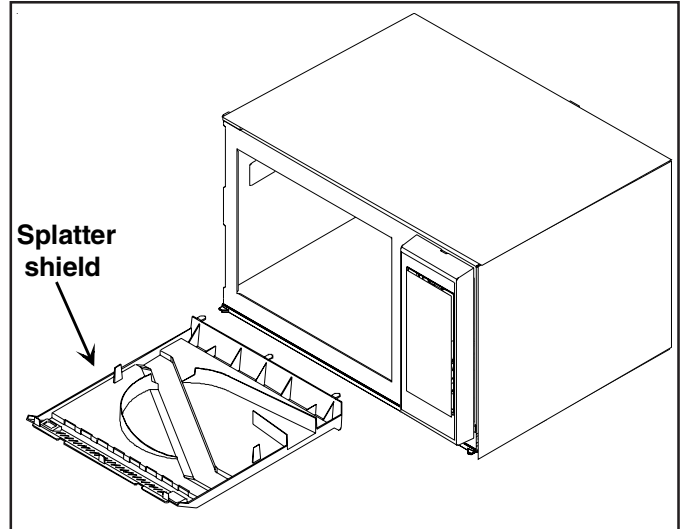

Antenna

1. Remove splatter shield from oven cavity.
2. Remove two mounting rivets on the top of oven cavity to remove cradle. Support cradle before removing mounting rivets to avoid damage to antenna assembly.

Stirrer Motor

1. Disconnect power to oven and remove outer case, (see "Outer Case" procedure).
2. Remove outer case.
3. Disconnect wire terminals from stirrer motor.
4. Remove screws securing stirrer motor to wave guide.
5. Replace component and reverse procedure to reassemble.

NOTE: When replacing stirrer motor, verify motor shaft is aligned with antenna shaft before securing with screws.

Disassembly Procedures



WARNING

To avoid the risk of electrical shock, personal injury, or death, disconnect power to oven and discharge the capacitors before following any disassembly procedure.

Magnetron Thermal Cut-Out (TCO)

1. Disconnect power to oven and remove outer case, (see "Outer Case" procedure).
2. Remove outer case.
3. Remove TCO by removing screws.
4. Disconnect wiring.
5. Replace component and reverse procedure to reassemble.

NOTE: When reconnecting wiring to thermal fuses the connectors must be tight.

Cavity Thermal Fuse

1. Disconnect power to oven and remove outer case, (see "Outer Case" procedure).
2. Remove outer case.
3. Remove thermal fuse mounting screw.
4. Disconnect wiring.
5. Replace component and reverse procedure to reassemble.

NOTE: When reconnecting wiring to thermal fuses the connectors must be tight.

Tray Replacement

1. Unplug oven from outlet.
2. Using a suction cup to pry upward on front portion and remove tray from unit.
3. Thoroughly clean and degrease sump area.
4. Clean oven cavity bottom where new oven tray will make contact using mineral spirits or any non-flammable degreasing solvent.

NOTE: Detergents, soap, and water are not sufficient to remove oil and grease.

5. Clean cavity with mild detergent to remove any remaining degreasing solvent and place new tray into unit.

Oven Light Removal

The light bulb for inside of the oven can be changed only from the side of the unit. On the left hand side of the oven is a metal plate with one screw. The light bulbs are located behind this plate.

Follow these steps to change the bulb:

1. Disconnect power to oven and remove outer case, (see "Outer Case" procedure).
2. Remove screw and plate from side of unit.
3. To remove bulb, turn it counterclockwise, being careful not to burn fingers or break the bulb.
4. Replace bulb with a 20 watt, 230 - 240 volt appliance bulb.
5. Reposition plate, being careful not to bend hinge tab. Replace and tighten screw. Do not operate oven without plate in place.

Appendix A

Quick Start Reference Guide

Refer to Product Safety Manual for Safety Statements
Complete Owner's Manual available online

The switching operation of this microwave oven can cause voltage fluctuations on the supply line. The operation of this oven under unfavorable voltage supply conditions can have adverse effects. This device is intended for the connection to a power supply system with a maximum permissible system impedance Z_{max} of **0.2 Ohms** at the interface point of the user's supply. The user has to ensure that this device is connected only to a power supply system which fulfills the requirement above. If necessary, the user can ask the public power supply company for the system impedance at the interface point.

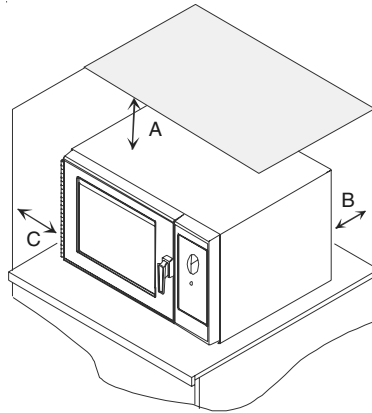

Oven Wall Clearances

- A—For North American (UL/CSA) models, allow at least 2" (5.1 cm) of clearance around top of oven. For International (50 Hz) models, allow at least 12" (30 cm) of clearance around top of oven. Proper air flow around oven cools electrical components. With restricted air flow, oven may not operate properly and life of electrical parts is reduced.
- B—Allow at least 2" (5.1 cm) between air discharge on back of oven and back wall.
- C—Allow at least 2" (5.1 cm) of clearance around sides of oven.

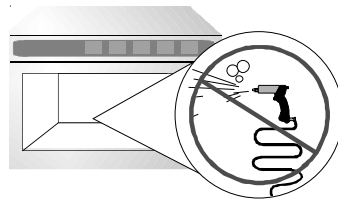

DO NOT power spray

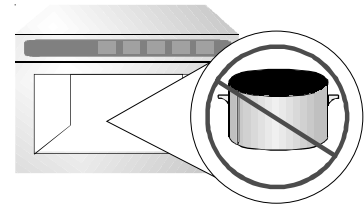

No metal pans

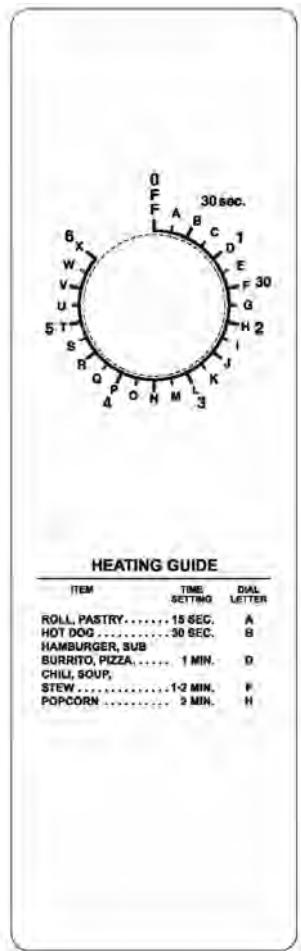

So...how do I use it? (Mechanical Dial)

Heating

1. Open oven door, place food in oven, and close oven door.
2. Turn time entry knob clockwise to desired time.
 - Cooking time can be set up to 6 minutes.
 - Oven begins operation and time counts down.
3. When cooking time has elapsed, microwave energy stops and oven signal sounds.

Interrupting Operation

Open oven door to interrupt operation or turn time entry knob counterclockwise to "0".

To resume microwave oven operation, close door and turn knob.

Changing Time and Canceling Mistakes

Heating time can be changed at any time while the oven is operating. Turn knob to desired new setting. To set cooking time to zero, turn knob counterclockwise to "0".

So...how do I use it? (Digital Dial)

Heating

- Open oven door, place food in oven, and close oven door.
- Turn time entry knob clockwise until desired time displays.
 - Factory default setting for cooking time is 10 minutes. Cooking time can be changed and set to 60 minutes. (Refer to section on changing options)
- Press a power level pad to change power level, if desired. If no power level is selected, unit will default to 100%.
 - Power level can be set from full power (100%), to 70%, 50% or DEFROST (20%).
- Press **START** button.
 - Oven begins operation and time counts down.
- When cooking time has elapsed, microwave energy stops and oven signal sounds.

Interrupting Operation

Open oven door to interrupt operation or turn time entry knob counterclockwise to "0".

To resume microwave oven operation, close door and press **START**.

If time was changed to "0", time will need to be reset, and then press **START**.

Changing Time and Power/Canceling Mistakes

Heating time and power level can be changed at any time while the oven is operating. Turn knob to desired new setting. To set cooking time to zero, turn knob counterclockwise to "0".



Part No.12804404
Revised 10/04

©2005 Maytag Services

:30 QUICK SET :30 QUICK SET Pad

Allows you to reheat for 30 seconds at 100% (full) power by simply pressing the :30 QUICK SET pad. By repeatedly pressing this pad, you can extend the reheating time to 5 minutes by 30 second increments. To change the time assigned to this pad:

- Open oven door.
 - If door is closed before programming is complete, changes are discarded.
- Press and hold the :30 QUICK SET pad for approximately 5 seconds.
 - This activates the programming mode.
 - Microwave will beep and either current or assigned time will show in display.
- Turn Dial to change time setting.
 - Time can be set from zero (0:00) seconds to five minutes (5:00).
 - If the assigned time is 0:00, the :30 QUICK SET pad is effectively disabled.
- Press **START** pad to save changes.



Can I change an option?

Options can be changed to suit individual preferences.

To change options:

- Open oven door.
 - If door is closed before programming is complete, changes are discarded and microwave exits options programming mode.
- Press and hold the Hidden Pad for approximately 5 seconds.
 - This begins options programming mode.
 - Microwave will beep and **OP:--** appears in display.
- Press the Hidden Pad to advance to the desired option to be changed.
 - See table below for options.
- Turn Dial to change option setting.
 - OP:** and option number appear in display.
 - See table below for options.
- Press **START** pad to save changes.
 - To change additional options, repeat steps 2 - 5.
 - Changes appear after door is closed.

Numbered Pads	Display	Options (Factory Settings in Bold)
1 End of Cycle Beep	OP:10 OP:11 OP:12	3 second continuous beep. Continuous beep until door is opened. 5 beep bursts until door is opened.
2 Speaker Volume	OP:20 OP:21 OP:22 OP:23	Eliminates beep. Sets volume to low. Sets volume to medium. Sets volume to high.
3 Key Beep	OP:30 OP:31	Prevents beep when pad is pressed. Allows beep when pad is pressed.
4 Keyboard Enable Window	OP:40 OP:41 OP:42 OP:43	15 seconds after oven door is opened, keyboard disabled. 30 seconds after oven door is opened, keyboard disabled. 1 minute after oven door is opened, keyboard disabled. 2 minutes after oven door is opened, keyboard disabled.
5 Add Time During Heating	OP:50 OP:51	Prevents adding heating time while oven is heating. Allows heating time to be changed while oven is heating when a memory pad is pressed.
6 Reset Door Open	OP:60 OP:61	Allows oven to resume heating time countdown after door is opened during cycle. Cancels heating time count down after door is opened during cycle.
7 (some models) Maximum Heating Time	OP:70 OP:71	Allows 60 minutes of heating time. Allows 10 minutes of heating time.
0 Clean Filter Message	OP:00 OP:01 OP:02 OP:03	Do not display message. Display message for 24 hours every 7 days. Display message for 24 hours every 30 days. Display message for 24 hours every 90 days.



For full product documentation visit:
www.amanacommercial.com/wavelink

© 2004 Amana Appliances
Amana, Iowa 52204

16025963

A-3

Quick Start Reference Guide

Refer to Product Safety Manual for Safety Statements
Complete Owner's Manual available online

CLEAN FILTER

This oven displays CLEAN FILTER at user defined intervals. When the message displays Amana recommends cleaning the air filter thoroughly. **Cleaning the air filter will not shut off the message.**

The message will stop displaying automatically after 24 hours. Depending on microwave use and environmental conditions, the filter may need to be cleaned more frequently. Once the frequency is determined, set the option for the appropriate time frame.

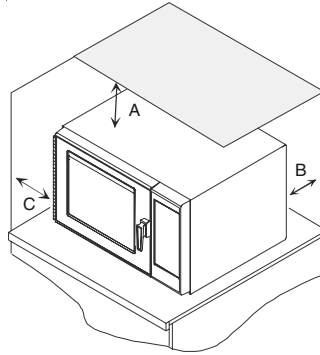

Oven Wall Clearances

- A—For North American (UL/CSA) models, allow at least 2" (5.1 cm) of clearance around top of oven. For International (50 Hz) models, allow at least 12" (30 cm) of clearance around top of oven. Proper air flow around oven cools electrical components. With restricted air flow, oven may not operate properly and life of electrical parts is reduced.
- B—Allow at least 2" (5.1 cm) between air discharge on back of oven and back wall.
- C—Allow at least 2" (5.1 cm) of clearance around sides of oven.

So...how do I use it? (Electronic Control)

7

Preprogrammed Pads

To cook food using preprogrammed cooking sequences:

1. Open oven door and place food in oven. Close door.
2. Press desired pad.
3. Oven begins to cook.
4. At end of cooking cycle oven beeps and shuts off.

QTY
2X

QTY 2X Programming (some models)

To change the cooking factor:

1. Open oven door.
2. Press and hold pad 1 for approximately 5 seconds.
3. Press pad to be reprogrammed.
4. Press the QTY 2X pad.
5. Press a numbered pad to change the cooking factor.
 - Cooking factor can be set from 10% to 100%.
 - Default is 80%.
 - Pad 5 would change the cooking factor to 50%.
6. Press START pad to save changes.

Manual Operation

To cook food using a specific entered time and power level:

1. Open oven door and place food in oven. Close door.
2. Press TIME ENTRY pad and enter cooking time.
3. Press a power level pad to change power level if desired (some models).
 - **COOK LEVEL** displays with the power setting.
4. If stage cooking is desired, press TIME ENTRY pad and repeat steps 2 through 4, (some models).
5. Press START pad.
6. At end of cooking cycle oven beeps and shuts off.

Programming Items

1. Open oven door.
2. Press and hold pad 1 for approximately 5 seconds.
3. Press pad to be reprogrammed.
4. Enter cooking time by using the number pads.
5. Press a power level pad to change power level if desired.
6. If stage cooking is desired, press TIME ENTRY pad.
 - Display briefly shows the stage number.
 - Display changes to cook time and power level for the next stage.
7. Enter cook time and power level as in steps 4 and 5 (some models).
 - To enter another cooking stage for that pad, press TIME ENTRY pad again.
 - Up to four different stages can be programmed (some models).
8. Press START pad to set new programming changes to the pad.

NOTE: To discard changes, press STOP/RESET pad or close oven door.

QTY 2X Pad (some models)

1. Open oven door and place food in oven. Close door.
2. Press QTY 2X pad.
3. Press desired preprogrammed pad or pad sequence.
4. Oven begins cooking. Displayed cooking time is the total of original cooking time and added 2X time.

The switching operation of this microwave oven can cause voltage fluctuations on the supply line. The operation of this oven under unfavorable voltage supply conditions can have adverse effects. This device is intended for the connection to a power supply system with a maximum permissible system impedance Z_{max} of **0.2 Ohms** at the interface point of the user's supply. The user has to ensure that this device is connected only to a power supply system which fulfills the requirement above. If necessary, the user can ask the public power supply company for the system impedance at the interface point.

Quick Start Reference Guide

Refer to Product Safety Manual for Safety Statements
Complete Owner's Manual available online

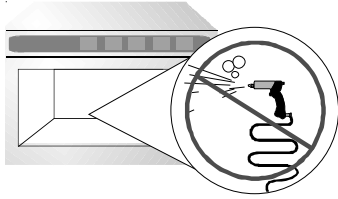

DO NOT power spray

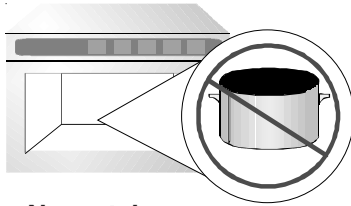

No metal pans

? Can I change an option?

Options such as single or double pad programming, beep volume, and maximum cooking time can be changed to suit individual preferences.

To change options:

1. Open oven door.
 - If door is closed or RESET pad is pressed before programming is complete, changes are discarded and microwave exits programming mode.
2. Press and hold pad 2 for approximately 5 seconds.
 - This begins options mode.
 - Microwave will beep and OP: displays.
3. Press number pad that controls option to be changed.
 - See table below for options.
 - Current option will display.
4. Press number pad again to change the option.
 - Each time pad is pressed, option will change.
 - Match code displayed with code for desired option.
5. Press START pad to save changes.
 - To change additional options, repeat steps 3 and 4.
 - Changes appear after door is closed or STOP/RESET pad is pressed.

Numbered Pads	Display	Options (Factory Settings in Bold)
1 End of Cycle Beep	OP:10	3 second beep.
	OP:11	Continuous beep until door is opened.
	OP:12	5 beep bursts until door is opened.
2 Speaker Volume	OP:20	Eliminates beep.
	OP:21	Sets volume to low.
	OP:22	Sets volume to medium.
	OP:23	Sets volume to high.
3 Key Beep	OP:30	Prevents beep when pad is pressed.
	OP:31	Allows beep when pad is pressed.
4 Keyboard Enable Window	OP:40	15 seconds after oven door is opened, keyboard disabled.
	OP:41	30 seconds after oven door is opened, keyboard disabled.
	OP:42	1 minute after oven door is opened, keyboard disabled.
	OP:43	2 minutes after oven door is opened, keyboard disabled.
5 Add Time During Heating	OP:50	Prevents adding heating time while oven is heating.
	OP:51	Allows heating time to be changed while oven is heating when a memory pad is pressed.
6 Reset Door Open	OP:60	Allows oven to resume heating time countdown after door is opened during cycle.
	OP:61	Cancels heating time count down after door is opened during cycle.
7 (some models) Maximum Heating Time	OP:70	Allows 60 minutes of heating time (some models).
	OP:71	Allows 10 minutes of heating time.
8 Manual Operation	OP:80	Allows use of preprogrammed pads only.
	OP:81	Allows use of manual time entry and preprogrammed pads.
9 (some models) Double Digit Operation	OP:90	Allows 10 (0-9) preprogrammed pads.
	OP:91	Allows 100 (00-99) preprogrammed pads.
0 Clean Filter Message	OP:00	Do not display message.
	OP:01	Display message for 24 hours every 7 days.
	OP:02	Display message for 24 hours every 30 days.
	OP:03	Display message for 24 hours every 90 days.