

Service

This manual is to be used by qualified appliance technicians only. Maytag does not assume any responsibility for property damage or personal injury for improper service procedures done by an unqualified person.

Neptune TL

This Base Manual covers general information
Refer to individual Technical Sheet
for information on specific models

This manual includes, but is
not limited to the following:

FAV6800A
FAV9800A

Important Information

Important Notices for Technicians and Consumers

Maytag will not be responsible for personal injury or property damage from improper service procedures. Pride and workmanship go into every product to provide our customers with quality products. It is possible, however, that during its lifetime a product may require service. Products should be serviced only by a qualified service technician who is familiar with the safety procedures required in the repair and who is equipped with the proper tools, parts, testing instruments and the appropriate service information. **IT IS THE TECHNICIANS RESPONSIBILITY TO REVIEW ALL APPROPRIATE SERVICE INFORMATION BEFORE BEGINNING REPAIRS.**

 WARNING
To avoid risk of severe personal injury or death, disconnect power before working/servicing on appliance to avoid electrical shock.

To locate an authorized technician, please consult your telephone book or the dealer from whom you purchased this product. For further assistance, please contact:

Customer Service Support Center

CAIR Center

Web Site	Telephone Number
WWW.AMANA.COM	1-800-843-0304
WWW.JENNAIR.COM	1-800-536-6247
WWW.MAYTAG.COM	1-800-688-9900
CAIR Center in Canada	1-800-688-2002
Amana Canada Product	1-866-587-2002

Recognize Safety Symbols, Words, and Labels

 DANGER

DANGER—Immediate hazards which **WILL** result in severe personal injury or death.

 WARNING
--

WARNING—Hazards or unsafe practices which **COULD** result in severe personal injury or death.

 CAUTION
--

CAUTION—Hazards or unsafe practices which **COULD** result in minor personal injury, product or property damage.

Table of Contents

Important Information	2	System Check	24
Important Safety Information	4	Service Cycle	25
General Information		Display Diagnostic Codes	25
Model Identification	8	Diagnostic Codes	25
Serial Label Location	8	Exit Service Mode	26
Model Nomenclature	9	Hose Reversal Detection And Correction	27
Model Specifications	10	Torque Specifications	27
FAV 6800AW Trouble Shooting		Tub Displacement Sensor Diagnostics	27
Trouble Shooting General Symptoms	12	Component Diagnostics	28
Consumer Help Codes	13	Water Leak Around Pulley Tub Bottom	28
Service Mode	14	Control Board Inputs Table	29
Accessing Service Tests	14	Membrane Pad Continuity Checks	29
Quick Spin Test	14	Disassembly Procedures	
Hold Quick Spin Step	15	Console Removal	30
Fast Time Down Test	15	Control Board Removal	30
Quick Service Cycle	15	Lid Disassembly/Removal	32
Membrane Pad Test	15	Top Cover Removal	32
Motor Control Board Output Test	15	Splash Guard Removal	33
Board Functional Test Input Control Keys	16	Bleach/Softener Dispenser Removal	33
Board Output Test	16	Lid Lock/Reed Switch Removal	34
Display Diagnostic Codes	17	Inlet Water Valve Removal	35
Diagnostic Codes	17	Detergent Dispenser Water Valve Removal	36
Exit Service Mode	18	Top Cover Removal	37
Hose Reversal Detection And Correction	18	Tumbler Removal	37
Torque Specifications	18	Tumbler Bearing Removal	39
Tub Displacement Sensor Diagnostics	19	Transmission/O-Ring Seal Removal	40
Component Diagnostics	19	Rear Strut Removal	40
Water Leak Around Pulley Tub Bottom	19	Front Panel Removal	41
Control Board Inputs Table	20	Tub Displacement Sensor Removal	41
Membrane Pad Continuity Checks	20	Front Strut Removal	43
FAV 9800AW Trouble Shooting		Drain Pump/Pressure Switch Removal	44
Trouble Shooting General Symptoms	21	Spinner Removal	45
Removing A Favorite Cycle	22	Outer Tub Removal	45
Enter/Exit Service Mode	23	Drive Motor Removal	46
Accessing Service Tests/Diagnostic Features	23	Pulley/Clutch Removal	47
User Interface Test	23	Drive Belt Removal	47
Quick Spin Test	23	Heater Assembly Removal	47
Hold Quick Spin Test	24	Motor Control Removal	47
		Spinner Support Removal	48
		Appendix A	
		Installation Instructions	50
		Appendix B	
		Use And Care	57

Important Safety Information



WARNING

To reduce the risk of fire, electric shock, serious injury or death to persons when using your washer, follow these basic precautions:

- Read all instructions before using the washer.
- Refer to the Grounding Instructions in the Installation Manual for the proper grounding of the washer.
- Do not wash articles that have been previously cleaned in, washed in, soaked in, or spotted with gasoline, dry-cleaning solvents, or other flammable or explosive substances as they give off vapors that could ignite or explode.
- Do not add gasoline, dry-cleaning solvents, or other flammable or explosive substances to the wash water. These substances give off vapors that could ignite or explode.
- Under certain conditions, hydrogen gas may be produced in a hot water system that has not been used for two weeks or more. Hydrogen gas is explosive. If the hot water system has not been used for such a period, before using a washing machine or combination washer-dryer, turn on all hot water faucets and let the water flow from each for several minutes. This will release any accumulated hydrogen gas. The gas is flammable, do not smoke or use an open flame during this time.
- Do not allow children to play on or in the washer. Close supervision of children is necessary when the washer is used near children. This is a safety rule for all appliances.
- Before the washer is removed from service or discarded, remove the lid to the washing compartment.
- Do not reach into the washer if the wash tub is moving.
- Do not install or store the washer where it will be exposed to water and/or weather.
- Do not tamper with the controls.
- Do not repair or replace any part of the washer, or attempt any servicing unless specifically recommended in the User-Maintenance instructions or in published user-repair instructions that you understand and have the skills to carry out.
- To reduce the risk of an electric shock or fire, do not use an extension cord or an adapter to connect the washer to the electrical power source.
- Use your washer only for its intended purpose, washing clothes.
- Always disconnect the washer from electrical supply before attempting any service. Disconnect the power cord by grasping the plug, not the cord.
- Install the washer according to the Installation Instructions. All connections for water, drain, electrical power and grounding must comply with local codes and be made by licensed personnel when required. Do not do it yourself unless you know how!
- To reduce the risk of fire, clothes which have traces of any flammable substances such as vegetable oil, cooking oil, machine oil, flammable chemicals, thinner, etc. or anything containing wax or chemicals such as in mops and cleaning cloths, must not be put into the washer. These flammable substances may cause the fabric to catch on fire by itself.
- Do not use fabric softeners or products to eliminate static unless recommended by the manufacturer of the fabric softener or product.
- Keep your washer in good condition. Bumping or dropping the washer can damage safety features. If this occurs, have your washer checked by a qualified service person.
- Replace worn power cords and/or loose plugs.
- Be sure water connections have a shut-off valve and that fill hose connections are tight. Close the shut-off valves at the end of each wash day.
- Loading lid must be closed any time the washer is in operational fill, tumble, or spin. Do not attempt to bypass the loading lid switch by permitting the washer to operate with the loading lid open.
- Always read and follow manufacturer's instructions on packages of laundry and cleaning aids. Heed all warnings or precautions. To reduce the risk of poisoning or chemical burns, keep them out of the reach of children at all times (preferably in a locked cabinet).
- Always follow the fabric care instructions supplied by the garment manufacturer.
- Never operate the washer with any guards and/or panels removed.
- Do not operate the washer with missing or broken parts.
- Do not bypass any safety devices.
- Failure to install, maintain, and/or operate this washer according to the manufacturer's instructions may result in conditions which can produce bodily injury and/or property damage.

NOTE: The Warnings and Important Safety Instructions appearing in this manual are not meant to cover all possible conditions and situations that may occur. Common sense, caution and care must be exercised when installing, maintaining, or operating the washer.

Always contact your dealer, distributor, service agent or the manufacturer about any problems or conditions you do not understand.

Important Safety Information

WARNING

To avoid personal injury or death from improper servicing, make sure you read and understand the descriptions and meaning of various safety symbols, words and labels used in this manual, before attempting any procedures described in the manual. Failure to understand and comply with safety information may result in severe personal injury or death.

General Information

This Service Manual describes the operation, disassembly, troubleshooting, and repair of the Neptune TL™ washer. It is intended for use by authorized technician's who troubleshoot and repair these units.

NOTE: It is assumed that users of this manual are familiar with the use of tools and equipment used to troubleshoot and repair electrical, and mechanical systems; and understand the terminology used to describe and discuss them.

Related Publications

This is a base service manual, covering a range of similar models. It is intended to be used in conjunction with the Parts Manual and Technical Sheet covering the specific model being serviced.

Electrical Service Information

Proper Grounding and Polarization of 120 Volts Wall Outlets

For the safety of our customers and the Service Technician ALL appliances have a three-prong power cord and MUST be connected to a properly polarized AND grounded wall outlet.

This information was written for those who do not understand grounding and polarization of a wall outlet. A 120 volt wall outlet must always be wired as shown below.

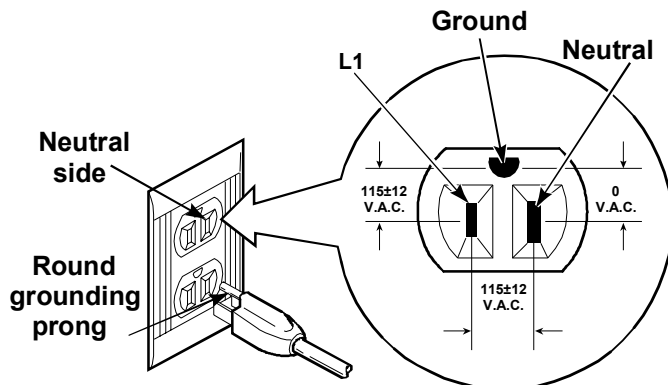

About Ground Wires

In the event of an electrical short circuit, a ground wire reduces the risk of electric shock by providing an escape wire for the electric current.

Standard accepted color coding for ground wires is **green** or **green with a yellow stripe**.

Grounding wires and wires colored like grounding wires are **NOT** to be used as current carrying conductors.

WARNING

To reduce the risk of fire, electric shock, serious injury or death, all wiring and grounding must conform with the latest edition of the National Electric Code, ANSI/NFPA 70, or the Canadian Electrical Code, CSA C22.1, and such local regulations as might apply. It is the customer's responsibility to have the wiring and fuses checked by a qualified electrician to make sure your home has adequate electrical power to operate the washer.

WARNING

To avoid risk of personal injury or death due to electrical shock:

- **Observe all local codes and ordinances.**
- Disconnect electrical power to unit before servicing.
- Ground appliance properly.
- Check with a qualified electrician if you are not sure this appliance is properly grounded.
- DO NOT ground to gas line.
- DO NOT ground to cold water pipe if pipe is interrupted by plastic, nonmetallic gaskets, or other insulating (nonconducting) materials.
- DO NOT modify plug on power cord. If plug does not fit electrical outlet, have proper outlet installed by qualified electrician.
- DO NOT have a fuse in the neutral or ground circuit. A fuse in the neutral or ground circuit could result in an electrical shock.
- DO NOT use an extension cord with this appliance.
- DO NOT use an adapter plug with this appliance.
- DO NOT pinch power cord.

Important Safety Information

Explanation

Polarization—This means that the larger slot must be neutral and the small slot must be at line voltage.

Mispolarized—The outlet is incorrectly wired so that the larger slot is at line voltage and the smaller slot is neutral.

Grounded—This means the round hole connection is connected to earth ground through a connection to the main power panel.

Ungrounded—The round hole connection is not complete to earth ground and/or the main power panel.

Grounding Instructions



WARNING

- To avoid the risk of electrical shock or death, do not alter the plug.
- Do not remove grounding prong when installing grounded appliance in a home that does not have three wire grounding receptacle. Under no condition is grounding prong to be cut off or removed. It is the personal responsibility of the consumer to contact a qualified electrician and have properly grounded three prong wall receptacle installed in accordance with appropriate electrical codes.
- To avoid the risk of electrical shock or death, this equipment must be grounded.

This equipment **MUST** be grounded. In the event of an electrical short circuit, grounding reduces the risk of electric shock by providing an escape wire for the electric current. This unit is equipped with a cord having a grounding wire with a grounding plug. The plug must be plugged into an outlet that is properly installed and grounded.

Consult a qualified electrician or technician if grounding instructions are not completely understood, or if doubt exists as to whether the equipment is properly grounded. Do not use an extension cord. If the product power cord is too short, have a qualified electrician install a three-slot receptacle. This unit should be plugged into a separate 60 hertz circuit with the electrical rating as shown in the appropriate drawing. Models operate with a supply voltage of 120 Volts.



CAUTION



THIS CONTROL BOARD IS INTENTIONALLY NOT GROUNDED AND MAY PRESENT A RISK OF ELECTRICAL SHOCK ONLY DURING SERVICING. SERVICE PERSONNEL—DO NOT CONTACT THIS PART WHILE APPLIANCE IS ENERGIZED.

Important Safety Information

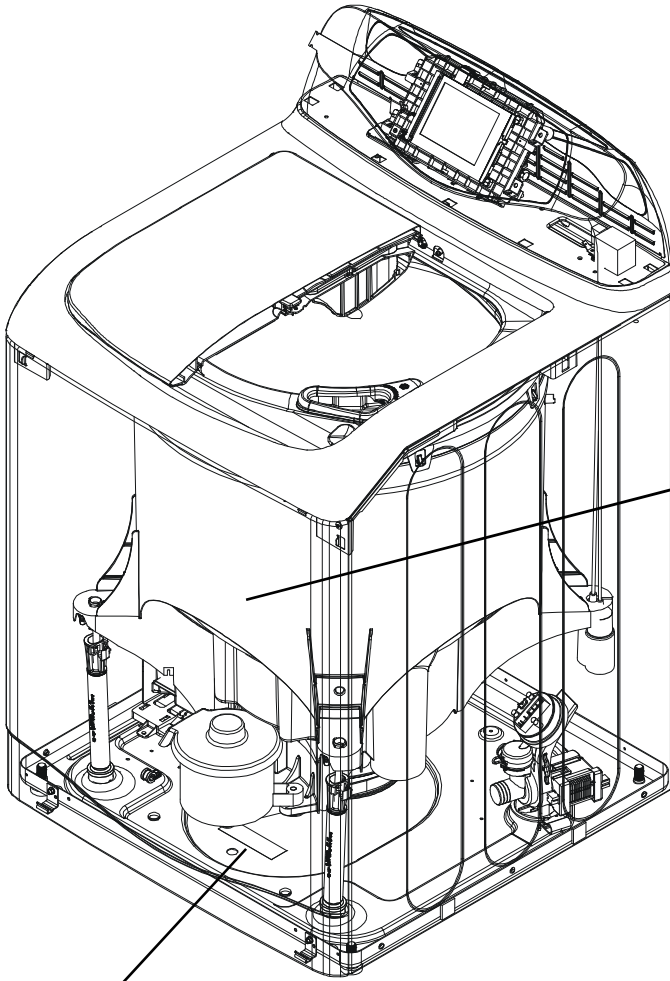

⚠ CAUTION ⓘ
KEEP CLEAR
ROTATING BELTS AND PULLEYS

⚠ CAUTION ⓘ
CONTROL BOARD, HEAT SINK, MOTOR AND PUMP ARE
INTENTIONALLY NOT GROUNDED AND MAY PRESENT A
RISK OF ELECTRICAL SHOCK, ONLY DURING SERVICING.

General Information

Model Identification

Complete registration card and promptly return. If registration card is missing:

- For Maytag product call 1-800-688-9900 or visit the Web Site at www.maytag.com
- For product in Canada call 1-866-587-2002 or visit the Web Site at www.maytag.com.

When contacting provide product information located on rating label. Record the following:

Model Number: _____
Manufacturing Number: _____
Serial or S/N Number: _____
Date of purchase: _____
Dealer's name and address: _____



Serial Label is located in the upper left hand corner of the cabinet back panel.

Service

Keep a copy of sales receipt for future reference or in case warranty service is required. To locate an authorized technician:

- For Maytag call 1-800-462-9824 or visit the Web Site at www.maytag.com.
- For product in Canada call 1-866-587-2002 or visit the Web Site at www.maytag.com.

Warranty service must be performed by an authorized technician. We also recommend contacting an authorized technician, if service is required after warranty expires.

Parts and Accessories

Purchase replacement parts and accessories over the phone. To order accessories for your product call:

- For Maytag product call 1-800-462-9824 or visit the Web Site at www.maytag.com.
- For product in Canada call 1-866-587-2002 or visit the Web Site at www.maytag.com.

Extended Service Plan

We offer long-term service protection for this new washer.

- Dependability Plus™ Extended Service Plan is specially designed to supplement Maytag's strong warranty. This plan covers parts, labor, and travel charges.
Call 1-800-925-2020 for information.

General Information

Neptune Nomenclature

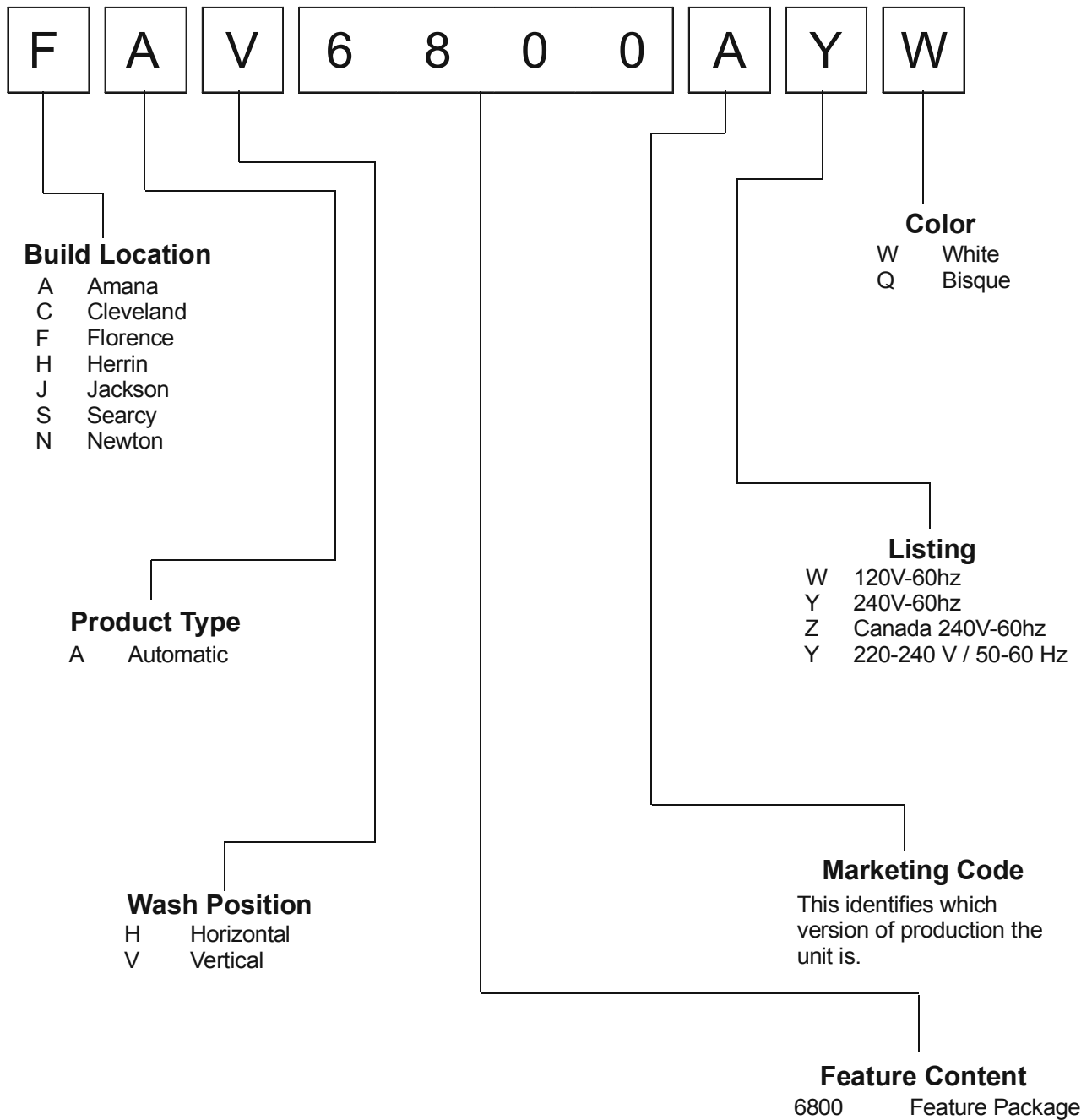

General Information

MAYTAG NEPTUNE® TL MODEL FAV6800AW

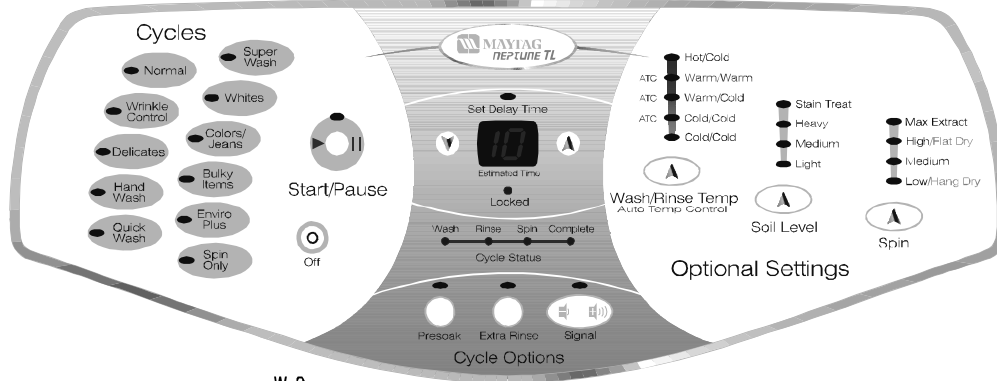

Color Availability	W, Q
Controls	LED
Time Remaining Indicator	•
Start/Pause Keypad	•
Graphics	Neptune® TL
Wash tub	301-Grade Stainless Steel
Capacity	3.5 cu. ft.
Tumblers	2
Speed Combinations	Infinite
TumbleClean™ Wash System w/Tumblers	•
Super Wash Fabric Cycle	•
Normal Wash Fabric Cycle	•
Whites Fabric Cycle	•
Wrinkle Control Fabric Cycle	•
Colors/Jean's Fabric Cycle	•
Delicates Fabric Cycle	•
Bulky Items Fabric Cycle	•
Handwash Fabric Cycle	•
Enviro Plus Fabric Cycle	•
Quick Wash Cycle	•
Spin Only Cycle	•
Delay Wash Option	1-9 Hours
Presoak Cycle Option	•
Stain Treat Option	•
Extra Rinse Option	•
Warm Rinse Option	•
MaxExtract™ Spin Option	•
Water Level Control	IntelliFill™
Water Temperature Combos	5
ATC (Energy Star)	Cold-Cold/Cold-85°/Warm-105°/Hot-Hot
Soil Level Control	Stain Treat/Heavy/Medium/Light
End-of-Cycle Chime	Variable
Showering Dispenser System	•
Automatic Detergent Dispenser	Timed
Automatic Bleach Dispenser	Timed
Automatic Fabric Softener Dispenser	Timed
Suspension	4 Struts
Top/Lid	Porcelain
Cabinet	QuadCoat™
Rear Leveling Legs	Stationary
Sound System	EQ Plus™
Spin Speeds	
MaxExtract™	850 (extended)
High/Flat Dry	850
Medium	650
Low/Hang Dry	550

Bold indicates new feature on that particular model.

Dimensions

Width: 27"
 Depth: 28"
 Height: 44³/₄"
 Height w/lid open: 55³/₄"

General Information

M A Y T A G N E P T U N E ® T L M O D E L F A V 9 8 0 0 A W

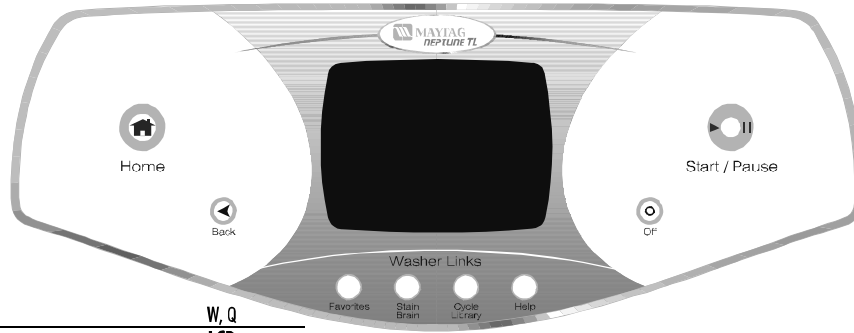

Color Availability	W, Q
Controls	LCD
Trilingual Touchscreen	English/French/Spanish
StainBrain™	60 Plus Preset Stains
Favorites	24 Memory Locations
Cycle Library™	24 Preset Cycles
Hints & Tips	•
Before You Call	•
Control Panel Lock-Out	•
Time Remaining Indicator	•
Start/Pause Keypad	•
Graphics	Neptune® TL
Wash tub	301-Grade Stainless Steel
Capacity	3.5 cu. ft.
Tumblers	2
Speed Combinations	Infinite
TumbleClean™ Wash System w/Tumblers	•
Super Wash Fabric Cycle	•
Normal Wash Fabric Cycle	•
Whites Fabric Cycle	•
Wrinkle Control Fabric Cycle	•
Colors/J Jeans Fabric Cycle	•
Delicates Fabric Cycle	•
Bulky Items Fabric Cycle	•
Handwash Fabric Cycle	•
Enviro Plus Fabric Cycle	•
Quick Wash Cycle	•
Spin Only Cycle	•
Delay Wash Option	1-12 Hours
Presoak Cycle Option	•
Stain Treat Option	•
Extra Rinse Option	•
Warm Rinse Option	•
MaxExtract™ Plus Spin Option	•
Water Level Control	IntelliFill™
Water Temperature Combos	8
ATC (Energy Star) Cold-Cold/Cold-85°/Warm-105°/Hot-Hot/Hot-115°	
AutoTemp™ Internal Water Heater	1200 Watt
Soil Level Control	Stain Treat/Heavy/Medium/Light/Freshen
End-of-Cycle Chime	Variable
Showering Dispenser System	•
Automatic Detergent Dispenser	Timed
Automatic Bleach Dispenser	Timed
Automatic Fabric Softener Dispenser	Timed
Suspension	4 Struts
Top/Lid	Porcelain
Cabinet	QuadCoat™
Rear Leveling Legs	Stationary
Sound System	Ultra EQ Plus™
Spin Speeds	
MaxExtract™	1000 (extended)
High/Flat Dry	850
Medium	650
Low/Hang Dry	550

Bold indicates new feature on that particular model.

Dimensions

Width: 27"
 Depth: 28"
 Height: 44³/₄"
 Height w/lid open: 55³/₄"

Troubleshooting Procedures



WARNING

To avoid risk of electrical shock, personal injury or death, disconnect power to unit before servicing, unless testing requires power.

Maytag Neptune™ TL FAV6800AW Washer

Diagnostic Code table follows later in this document.

Will Not Start

- Plug cord into live electrical outlet.
- Check fuse or reset circuit breaker to outlet.
- Close lid and push the START/PAUSE button to start washer. The START/PAUSE LED should change from flashing to on continuously.
- Check to see if the washer is in a pause or soak period of the cycle. Wait briefly for cycle to advance.
- Check for restricted drain system.
- Check the lid, lid latch mechanism, and circuitry (see Will Not Lock).

Leaking

- Make sure supply hose connections are not leaking. Check for rubber gasket damage due to over-tightening.
- Make sure end of drain hose is correctly inserted and secured to drain facility.
- Check bottom of tub around the pulley. See special instructions page 19.
- Check internal hose connections (fill & drain systems, hoses & clamps).
- Check tub cover. Remove, reposition and reinstall the tub cover seal. Seal seam must be at the top of the tub cover.
- Make sure water dispensing system on inner lid is securely attached to lid.
- Make sure dispenser valve is securely attached to mounting bracket.
- Check standpipe for leak. Wrap a dry rag around the standpipe opening. If rag becomes wet leak is fault of home plumbing. Be sure the standpipe is capable of accepting the flow of water from the washer.
- Check the lid hinges if water is coming out behind the lid.
- Check for bowing of lid where water enters detergent dispenser.

Display Lights Up When Lid is Opened

- This is normal behavior.

No Tumble

- Start normal cycle with an empty machine and allow a fill to check tumble.
- Fabric cycles such as NORMAL, DELICATES, HAND WASH, & WRINKLE CONTROL only tumble periodically, every 60 seconds.
- Check for loose connections at machine control board, motor control board and motor.
- Perform **Motor and Motor Control Test**.
- Washer does not tumble during most fills or during presoak.
- Washer with heat option does not tumble while heating.
- Check belt.

Will Not Spin

- During fill cycle – If machine tumbles and spins simultaneously replace clutch assembly.
- During spin cycle – If machine tumbles and spins simultaneously replace clutch assembly.
- Perform **Motor and Motor Control Test**.
- Check belt.
- Check that the machine control correctly senses that all 3 water levels are empty. See **Board Input Test**.
- Tub Displacement Sensor disconnected, or loose wire.

No Water Fill

- Go to **No Fill Test**.
- Check to make sure water supply is turned on fully.
- Normal water level is 1 to 7 inches inside the spinner.
- Check electrical circuit and connections at the water valve, and pressure switch.
- Check for kinks in inlet hoses.
- Check for clogged inlet screens.
- Visually check hot and cold separately for fill.
- Check for low water pressure. May be dependent on pressure entering home. Variations may occur due to usage in the home at the time machine is used.
- Check for frozen pipes and hoses.

Tub Full of Suds

- Check for restricted drain system.
- Check for loose wire connections at control board and pump.
- Perform **Motor and Motor Control Test**.
- Use high efficiency or low sudsing detergent specially formulated for front load washers.
- Run the clothes washer through another complete cycle using the coldest water and no detergent.
- Reduce detergent amount for that specific load size and soil level. Towel loads have a minimal amount of soil present and typically create more suds.
- Check to see if belt is off motor and pulley.

Wet Clothes

- Very small clothes loads can cause unbalanced loads - add additional towels.
- Excessive suds may have been present.
- Check Tub Displacement Sensor connection and main harness connector at machine control board.
- Check Tub Displacement Sensor for 0 to 3.0 Volts DC output voltage between ground and the board input. Check for 12 Volts DC input voltage between the ground and the board output. Only check for voltage at the Tub Displacement Sensor. Do not perform a continuity check. See **Tub Displacement Diagnostics**.

Troubleshooting Procedures



WARNING

To avoid risk of electrical shock, personal injury or death, disconnect power to unit before servicing, unless testing requires power.

- Excessive motion was detected in spin (**dc** or **LL**)
Run Quick Spin Test with an empty tub to check Tub Displacement Sensor and Machine Control Board.
- Check for restricted drain system.
- Perform **Motor and Motor Control Test**.

Will Not Lock

- Lid not all the way closed or not properly aligned.
- Check electrical connections at lock assemblies, machine control board, and Motor Control Board.
- Magnet missing. (Located on the back side of dispenser assembly inner lid, front Left corner).
- Laundry load is too large to close lid.
- Check system relay for welded contacts. (Diagnostic code 34) Disconnect power. Continuity between p.6 pin 1 to p.8. pin 1 at the Machine Control Board connector.
- Go to Lid Lock Test.
- Make sure inner lid is properly assembled to lid.
- Make sure door lock bumpers are fully seated to top cover.

Will Not Unlock

- Press **off**. The motor control is not responding if it takes 4 minutes to unlock. The motor control is either bad or disconnected.
- Unplug and reconnect power cord. Wait 20 seconds for machine to unlock.
- Check lid locked switch circuit. Circuit should be closed at machine control. (**See board input/output chart**)
- Check for loose electrical connections at lid lock and at machine control board.
- Push lid closed to make sure nothing from inside is pressing against it which may keep it from unlocking.
- Perform **Motor and Motor Control Test**. (see **Motor and Motor Control Test** section).
- If necessary, remove clothes by disconnecting power to washer, and open top cover with a putty knife.

Will Not Drain

- Check for restricted drain system.
- Check low, medium, and high water fill completion. Go to **No Fill Test**
- Check for 120 VAC at the pump when a spin cycle is selected < 550 rpm.
- Go to **Board Output Test** and perform Pump out test.
- In cold climates check for frozen Drain Hose.

Wrong Water Temperature

- Too Hot/Too Cold: This washer uses a reduced amount of water, while the control board meters the incoming flow to regulate the actual temperature of the water in the tub. This may appear to be significantly warmer/cooler than expected.
- Check that both faucets are on fully.
- Make sure the temperature selection is correct.
- This washer will compensate for reversed fill hoses. See **Hose Reversal Detection**.
- Make sure water heater is set to deliver a minimum of 120°F (49°C) hot water at the tap. Also check water heater capacity and recovery rate.
- If the water heater is located a long distance from washer, the water line may need to be purged prior to starting wash cycle.
- Disconnect inlet hoses and clean screens.

- The washer will need to go through a Hot / Cold cycle if the fill hoses were previously installed incorrectly and then corrected.
- Check Water Valve Thermistor. Resistance a room temperature is 61700 ohms. (**See board input/output chart**)

Noise / Cabinet Hits

- Level the machine
- Check sensor (refer to Tub Sensor Test).
- Check Strut and Strut Isolator for proper operation.
- Check for Diagnostic Code "10".

Consumer Information Codes

If the consumer observes codes on display, see table below.

LED Display	Description
CL	Closed: Lid is closed.
dc	Distribute Clothes: The load is unbalanced, preventing high speed spin. Redistribute clothes.
FL	Failed to Lock: The machine has repeatedly tried to lock the lid. Make sure the lid is shut completely.
LO	Locked: Lid has failed to unlock - the machine has repeatedly tried to unlock the lid. Push lid closed to make sure nothing from the inside is pressing against the lid, preventing unlocking.
Lr	Locked Rotor: The machine has repeatedly tried to turn the motor.
nd	No Drain: The machine has tried to drain.
OP	Lid is Open: Make sure it is fully closed before starting cycle.
od	Open the Lid: The lid has not been opened for the last three completed cycles.
nF	No fill: the machine has tried to fill. See No Water Fill.
PF	Power failure: Power to the machine has been lost during the last cycle. This may also occur on start up of a new machine due to factory testing. Check the lid. Press any key to return the display to normal activity.
Sd	Suds: Machine has detected high level of suds. The machine will alter its cycle for this situation. Use hE detergent or reduce the amount of detergent.
UL	Latch Unlocked: Close lid tightly to enable locking.
UC	Continuous Unbalanced Circuit. See Wet Clothes Troubleshooting. Improper signal from Tub Displacement Sensor.

Troubleshooting Procedures



WARNING

To avoid risk of electrical shock, personal injury or death, disconnect power to unit before servicing, unless testing requires power.

LED Display	Description
UB	See Diagnostic Code 10
LL	Large Load Detected
CL	Clear To Reset Cycle Counts
oL	Machine Paused-Load Wedging

Service Mode

Service Mode enables service personnel to verify the operation of the washing machine and diagnose problems. Service Mode can be entered in the middle of any wash cycle without interrupting the cycle. While in Service Mode, the technician can cancel the current cycle, set a continuous running mode, start a variety of special service tests and view diagnostic displays.





Enter / Exit Service Mode





To enter Service Mode press the **Enviro Plus** and **Spin Only** keys for three seconds or until the control beeps. The motor speed will be displayed when started (motor not running display will be 00). The present state of the machine will not be changed. (i.e., the current cycle in progress will not be interrupted and only the display will change).

To exit: 1) Press **Enviro Plus** and **Spin Only** keys for 3 seconds again, or 2) press **Off**, or 3) unplug the machine.

The following table summarizes special tests and features available in Service Mode, along with methods of activation and cancellation.

Accessing Service Tests and Diagnostic Features while in Service Mode.

Test or Display	Press LED to Start	Press LED to Cancel
 Quick Spin Test	Press Hand Wash	Press Off (exits Service Mode)
 Hold Quick Spin Step (holds predefined RPM)	Press Hand Wash (during test)	Press Hand Wash (cancels hold & resumes next step)
 Fast Time-Down / Advance to Next Step	Press Quick Wash during cycle	
 Quick Service Cycle	Press Wash/Rinse Temp ↑ (up) key	Press Off (also exits Service Mode)

Test or Display	Press LED to Start	Press LED to Cancel
Hold Quick Service Cycle Step	Press Signal ↑ (up) and ↓ (down) together	Press Signal ↑ (up) and ↓ (down) to resume
 Membrane Test	Press Presoak (then individual buttons to test)	Press Off twice after starting test
 Board Input Test	Press Super Wash	Press Super Wash
 Board Output Test / System Check	Press Delicates	Press Delicates
 Diagnostic Code Display (Initial)	Press Wrinkle Control – 1 st code displays	Press Wrinkle Control again
All Diagnostic Codes	Press Set Delay ↑ or ↓	N/A
Cycle Count No. for Diagnostic Code	Press and hold Normal while diagnostic code is displayed	Release Normal (returns to diagnostic code display)
Clear All Diagnostic Codes	Press Quick Wash + Whites together while displaying diagnostic codes	
Display Software Version	Press Bulky Items 3 times 1 st press- major soft. revision 2 nd – minor soft revision	Press Bulky Items a 4 th time
Cycle Count	Signal +: 10's and 1's digits Signal -: 100's and 1000's digits Colors/Jeans: 10-thousands & 100-thousand digits	



Quick Spin Test

While in Service Mode, press the **Hand Wash** key to start a **Quick Spin Test**.

Quick Spin test steps are as follows:

- 1) Lock the lid.
- 2) Spin to index speed 90 rpm and hold for 60 seconds. Pump drains machine.
- 3) Spin to index speed 150 rpm and hold for 6 seconds.

Troubleshooting Procedures



WARNING

To avoid risk of electrical shock, personal injury or death, disconnect power to unit before servicing, unless testing requires power.

- 4) Spin to index speed 350 rpm and hold for 6 seconds.
 - 5) Spin to index speed 550 rpm and hold for 6 seconds.
 - 6) Spin to index speed 700 rpm and hold for 6 seconds.
 - 7) Spin to index speed 850 rpm and hold for 6 seconds. Pump out.
 - 8) Coast down to 0 rpm chimes 3 times.
5. Warm softener fill: Energize cold water and fabric softener valves until medium level is reached. Advance to next step if water is not connected to machine.
 6. Drain and Spin to 850 rpm.
 7. Display a “PA” (Passed) continuously for 5 seconds if no diagnostic codes were logged during the test.
 8. Unlock the lid when the RPM is zero.

Speed Range	Displayed
a) 0-99 rpm	0-99 (actual)
b) 100-999 rpm	Speed X 10 ex: 85.= 850rpm

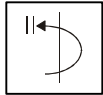

Hold Quick Spin Step

If the **Hand Wash** key is pressed again during the Quick Spin test, the machine will hold at the next highest index speed for up to 30 minutes. To cancel press the Hand Wash key again.

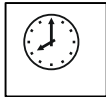

Fast Time Down Test

While any test or cycle is running in Service Mode, pressing the **Quick Wash** key will advance the program to the next cycle stage.

For example if in one of the following:

Stage of Wash Cycle	Advances To
Presoak	End of Presoak
Wash	Every 5 Minutes of Wash Time
Spin/Drain	End of the Spin Profile
Rinse	End of Rinse



Quick Service Cycle

While in Service Mode, pressing the **Wash/Rinse Temp** key will start a Quick Service Cycle. This will be a quick check of all systems. If display shows **od** then open and close lid. Pressing **Quick Wash** will advance to the next cycle. The following steps are performed: Display shows “sc”.

1. Lock lid and pump starts.
2. Cold bleach fill. Energize the cold and bleach water valves to low setting. Advance to next step if water is not connected to machine.
3. Tumble using 48 rpm tumble for 10 seconds.
4. Tumble with hot fill: Continue tumble while energizing hot water valve for 5 seconds.

If a diagnostic code is logged during the test, the right-most dot will turn on and stay on until quick service cycle test has ended. Any diagnostic code logged during this test will result in failure of the test, but will not necessarily stop the test.

During the Quick Service Cycle, pressing the **Quick**

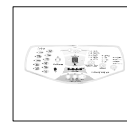

Wash key will advance to the next step.

Pressing the **Hand Wash** key will suspend the machine at the current step for up to 30 minutes or until **Hand Wash** is pressed again. All LEDs should flash on and off

while the system is suspended or on hold.

Membrane Pad Test

While in Service Mode, pressing the **Presoak** key will start a membrane switch check that verifies switch operation. All the LEDs (except **Presoak**) can be toggled or slewed by pressing the key associated with the LED or set of LEDs. Each time either set delay arrow is pressed the digits toggle between a blank and \square . All keys (including the **OFF** button) must be pressed within 5 minutes for this test to pass. “PA” will be displayed for five (5) seconds once all keys have been pressed and the test is completed. Following 10 seconds of inactivity at any point, this test will exit without any display.

Motor Control Board Output Test

1. Disconnect power to the washer.
2. Remove the front panel and disconnect the JP4 Connector from the Motor Control Board.
3. Reconnect the washer power cord to supply voltage. Make sure the lid is closed.
4. Press **Enviro Plus** and **Spin Only** keys for 3 seconds to activate Service Mode.
5. Access **Board Output Test** by pressing the **Delicates** key. Display shows “ot”.
6. The lid must be locked to access **Motor Control Board Output Test**. To lock the lid press **Colors/Jeans**. To verify the test, the quick wash LED will be on, indicating the system relay is activated. If off, press **Quick Wash** with the lid shut to activate.
7. Press **Whites** to start the motor control output test. This will send 120VAC to the motor control board. The motor control will execute a test routine and the motor should run, rotating the spinner at 50 rpm. There could be up to a 20 second delay before the spinner starts rotating.

Troubleshooting Procedures

⚠ WARNING

To avoid risk of electrical shock, personal injury or death, disconnect power to unit before servicing, unless testing requires power.

8. If motor does not run: Check for 120 VAC at the motor control board harness between L1 and Neutral. **See Illustration**



If voltage is present, then problem exists with the motor and motor control system.

- Check for loose electrical connections at motor, and motor control board.
- Check phase windings of the motor. **See Illustration.** If motor windings are good, replace the motor control board.

Diagram - Motor Harness

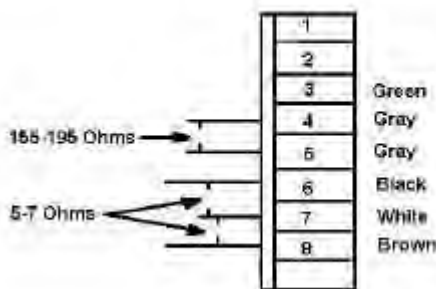

If voltage is not present;

- Check for loose electrical connections at Machine Control Board or broken wires in harness.
- Check lid actuator switch and related wiring. The lid must be closed and locked by pressing **colors/jeans**. The system relay is then activated and the quick wash LED is lit.

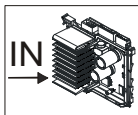

Board Functional Test Input Control Keys

While in Service Mode, pressing the **Super Wash** key will begin the **Board Input Test**.

This test turns on a specified output after a key press. Pressing the **Super Wash** key again cancels the test. (Display shows $\overline{0}$).

While in Service Mode press the following key to check respective function.

Key	Function	*Display
Normal	Lid Position	$\overline{0}$ P or $\overline{0}$ L
Wrinkle Control	Lock State	UL or LD
Whites	**High Water Level	- $\overline{0}$ or -!
Colors / Jeans	**Medium Water Level	- $\overline{0}$ or -!
Bulky Items	**Low Water Level	- $\overline{0}$ or -!
Enviro Plus	*** Water Temperature	8 88

*- $\overline{0}$ Indicates Pressure Switch not satisfied for that water level.

- | Indicates Pressure Switch satisfied for that water level.

**The appropriate water level must be added before running test.

1. For "High Water Level" enter the "**Board Output Test**" and select **Spin Only**. Exit "**Board Output Test**" after water fill and enter "**Board Functional Test**".
2. For "Medium Water Level" start a **Normal** cycle. After water fill stop cycle and enter "**Board Functional Test**".
3. For "Low Water Level" start a **Enviro Plus** cycle. After water fill stop cycle and enter "**Board Functional Test**".

***Note: For the water temperature, the value could be three digits, in which case the first digit will be displayed separately from the other two (2) digits. The two displays will be shown alternately. Each temperature will be displayed by default in Fahrenheit units and can be changed to Celsius units by pressing either Set Delay Time Arrow key (up or down).

Board Output Test

While in Service Mode, pressing the **Delicates** key will begin the **Board Output Test**. This test turns on a specified output after a key press. (Pressing the **Delicates** key again cancels the test.) All outputs will be turned off after five (5) minutes.

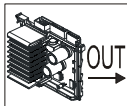

While in Service Mode press the following key to check respective function.

Key	Function
Normal	Hot Water Valve
Wrinkle Control	Fabric Softener Valve
Whites	Motor Control
Colors / Jeans	Lid Lock*
Bulky Items	Bleach Valve
Spin Only	Cold Water Valve
Quick Wash*	Toggle System Relay
Presoak	Drain Pump
Extra Rinse	Lid Unlock*

Troubleshooting Procedures



WARNING

To avoid risk of electrical shock, personal injury or death, disconnect power to unit before servicing, unless testing requires power.

***Note: Function may not occur for up to 20 seconds. While in the Board Output Test, the Quick Wash LED is always ON. When the Neptune TL is plugged in, the Machine Control Board will check the lid latch mechanism every 20 seconds. If found to be locked with no cycle running, the Control Board will send a signal to the switch to unlock the lid.**



Display Diagnostic Codes

The diagnostic code display can be toggled on and off from Service Mode by pressing the **Wrinkle Control** key. The display will show a "d".

The diagnostic codes can be viewed by using the **Set Delay Time** arrow keys. The **Set Delay Time** down arrow key will cycle down the list one code at time each time it is pushed. The Set Delay Time up arrow key will cycle up the list one code each time it is pushed. The first time the **Set Delay Time** down arrow key is pushed, the newest code will be displayed. A code generated during or after the current cycle will be displayed with the rightmost dot "." turned "ON".

Access Other Features

While a diagnostic code is displayed, if the **Normal Cycle** key is pressed and held, the machine will display the number of cycles since the diagnostic code occurred. To clear the diagnostic list press the **Quick Wash** and **Whites** key while viewing the list. The cycle count for each diagnostic code will also be reset to 0, but not the machine cycle count.

Diagnostic Codes

Diag. Code	Description	Trigger	Action to be taken
1	No Drain	The water level fails to drop below the Low level before a spin	Displays "nd" Go to "Will Not Drain" Troubleshooting Section
2	The lid fails to unlock	Lid failed to unlock after multiple attempts	Displays "LO" Go to "Will Not Unlock" Troubleshooting Section
3	No Fill	Total fill 14 minutes exceeded.	Displays "nF" Go to "No Water Fill" Troubleshooting Section
4	The lid fails to lock	Lid failed to lock after 11 attempts	Displays "FL" Go to "Will not unlock" Troubleshooting Section

Diag. Code	Description	Trigger	Action to be taken
5	Continuous unbalanced circuit. Out of balance circuit	See section for unbal. loads. (During spin only)	Displays "uC" Go to "Wet Clothes" Troubleshooting Section
6	Locked Rotor forcing a shut down.	Locked rotor is still locked after 10 attempts.	Displays "Lr" Go to "Motor Control Board Output Test"
8	Water level sensor fault.	Higher water levels were sensed while the lower water levels were not.	Go to "No Water Fill Test"
10	Unbalance or cabinet hit detected during final spin, which prevented the spinner from exceeding 500 rpm	Less than 500 rpm due to an unbalanced load.	LED – Will display "ub" Go to "Wet Clothes" Troubleshooting Section
11	Will not remember machine settings	Difficulty in reading memory	Go to "Clear diagnostic codes" Disconnect and reconnect the washer power cord at power supply outlet. If condition still exists, replace machine control board.
15	Stuck Key	Detected a key pressed more than 75 seconds. The key is assumed to be stuck.	Go to "Membrane Pad Check" Check connection of keypad to control board. Replace console if necessary.
16	High speed not achieved due to torque.	Speed less than 400 rpm during a main wash cycle.	Go to "Wet Clothes" Troubleshooting Section
17	The lid was not opened after completed wash cycles.	Did not sense lid open after the last three completed cycles.	LED – Will display "od" Customer may have tried to repeat wash cycle without opening the lid. Go to "Lid Lock Test"

Troubleshooting Procedures



WARNING

To avoid risk of electrical shock, personal injury or death, disconnect power to unit before servicing, unless testing requires power.

Diag. Code	Description	Trigger	Action to be taken
18	Detected lid lock switch open during cycle when not expected.	Open lid lock switch with motor running.	Check for loose wire connections. Clear the diagnostic code and recheck; if reoccurs, perform Diagnostic Motor/Motor Control Board test . Check for faulty motor relay on the machine control board.
22	Detected lid switch open during cycle (when not paused).	Detected lid sensor switch open and the lid locked switch locked.	Go to " Lid Lock Test " Troubleshooting Section
23	Lid is locked at start of cycle	Lid lock is locked and a user tries to start a cycle.	Go to " Will Not Unlock " Troubleshooting Section
24	Motor high RPM detected two times	Motor tach signal is seen at maximum speed.	Replace motor control board.
25	Motor tach signal exists without motor running	Tach signal exists without torque input. (Abnormal condition only)	Replace motor control board.
28	Water valve thermistor failure	Abnormal high/low temp or ohm resistance seen	Go to " Wrong Water Temperature " Troubleshooting Section
34	Welded system relay	Change of state of the relay	Disconnect power. Continuity between p.6 pin 1 to p.8. pin 1 at the Machine Control Board connector.
40	Washer not operating due to tumble not functioning	Load bound up.	LED – Will display "oL" The washer is unable to complete its cycle. The paddles cannot move. To continue, separate and redistribute the load, then press "start/pause".

presses) in Service Mode, the machine will exit the Service Mode and resume normal operations. Pressing the **Off** key will completely exit Service Mode. If a cycle is running, cancel the cycle. Pressing the **Start/Pause** key while running a test will pause the individual test, while remaining in Service Mode. A power loss during Service Mode will cancel this mode.

Hose Reversal Detection and Correction

The washing machine has diagnostic features that determine if the hoses are reversed on the first complete cycle after power up. The control board monitors water temperatures during the wash cycle.

The control system is capable of detecting hot and cold water intake hose reversal and will change the fill temperature as necessary after the first cycle. The control system stores and retains hot and cold water intake hose reversal information which is detected on the first three complete cycles after power up.

The system reverts to factory defaults for the cold and hot water valves and cancels hose reversal detection if a diagnostic code 28 has been logged in a cycle. See "**Wrong Water Temperature**" in the troubleshooting tips, at the beginning of this document for more information.

Torque Specifications

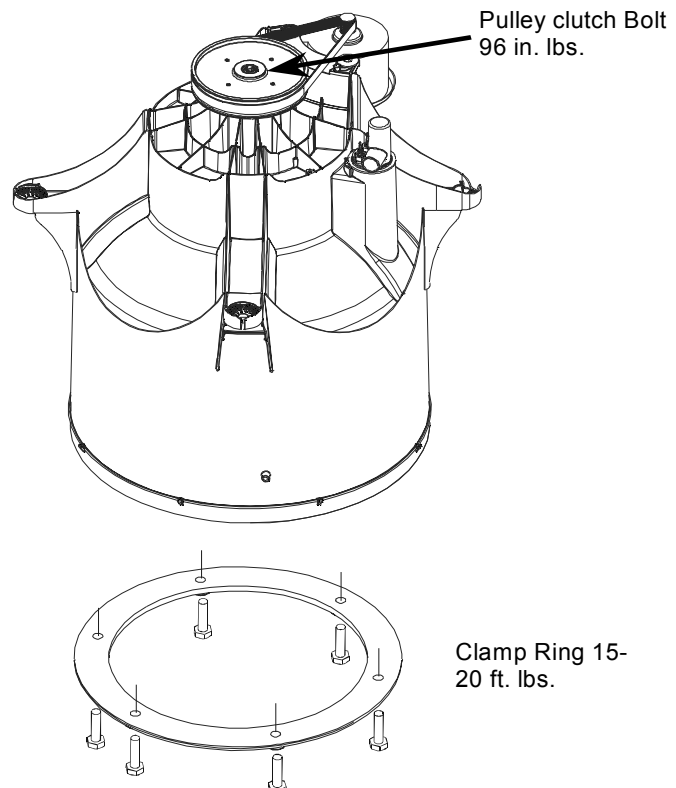

Exit Service Mode

To exit: 1) Press **Enviro Plus** and **Spin Only** keys for 3 seconds again, or 2) press **Off**, or 3) unplug the machine. After five (5) minutes of inactivity (user key

Troubleshooting Procedures



WARNING

To avoid risk of electrical shock, personal injury or death, disconnect power to unit before servicing, unless testing requires power.

Torque Specifications Continued

Spinner Support Shaft Nut 64-80 ft. lbs. Special wrench required.

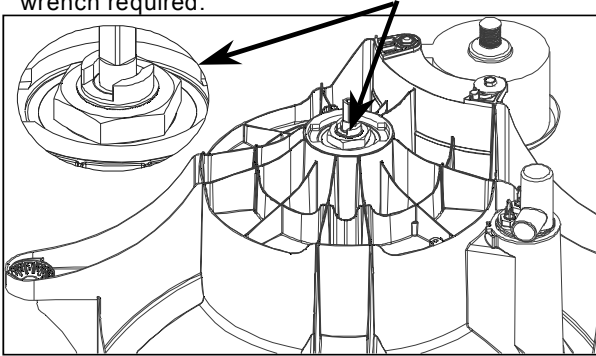

Tub Displacement Sensor Diagnostics

CAUTION: Do not perform continuity check directly on Displacement Sensor due to the potential for damaging the microprocessor chip in the sensor.

1. Enter the Service Mode by pressing and holding the **Enviro Plus** and **Spin Only** keys for three seconds.
2. Press the **Super Wash** key.
3. Press **Delicates**.
4. Push tub to back right corner so sensor extends beyond the #2 mark molded on slider. Display will show "UO" (Unbalance open).

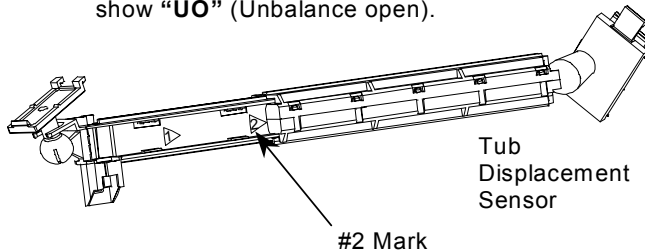

5. Press **Hand Wash**.
6. Pull tub to front left corner and push down so sensor collapses to before the #1 mark molded on slider. Display will show "UO" (Unbalance open).

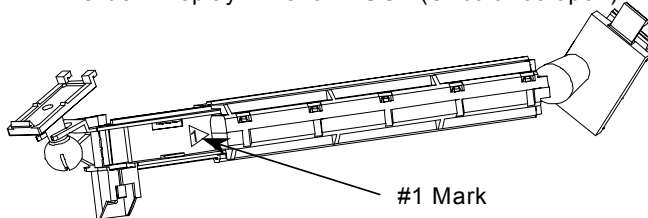

NOTE: Moving the sensor midway between mark #1 and mark #2 represents normal operation. Press **Hand Wash** or **Delicates**. Display will show "UC" (Unbalance Closed).

Component Diagnostics

NOTE: Unplug lower harness connector under console and test from wire insertion side.

Component Check	Pin	Wire Color	Range
Drain Pump	2 and 11	WH and RD/BK	0 to 30 Ohms
Pressure Switch Low Level	4 and 13	BR and RD/W H	0 to 20 Ohms (no water in machine)
Pressure Switch Med Level	13 and 14	PU and RD/W H	0 to 20 Ohms (no water in machine)
Pressure Switch High Level	1 and 9	GY/BK and YL/BL	0 to 20 Ohms (no water in machine)

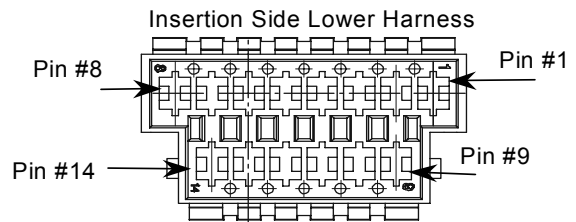

Special Instructions Water Leak Around Pulley On Tub Bottom

Water leaking around the pulley on the bottom of the tub, check the following:

1. Remove the Transmission. The Transmission should be approx. 1/3 full of oil. The oil in the Transmission should be thick, similar to a high viscosity motor oil. Tip the Transmission slightly, the oil should move slowly. If the Transmission is nearly full or if the fluid is very thin and moves quickly, the Transmission has water in it. Replace the Transmission, O-Ring, Spinner Support, Tub Seal and Outer Tub.
2. If no water is inside the Transmission, check the integrity of the O-Ring. Look for signs of water or rust on and around the Input Shaft. If the O-Ring is bad or there are signs of water or rust around the input shaft, replace the spinner support, tub seal and the outer tub.
3. If there was no water in the Transmission or around the top of the Input Shaft, it is likely the water was leaking through the Tub Seal. Replace the Outer Tub and Tub Seal. Inspect the Spinner Support for damage around the Tub Seal area. Replace the Spinner Support if it is damaged.
4. The Clutch Assembly should be inspected for signs of water or oil contamination. Clean Clutch Assembly as needed. Replace Clutch Assembly when water or oil contaminates the roller clutches.

Note: Oil in a new Transmission is clear. During operation, the oil will turn a dark color caused by the special compounds in some of the bushings.

Troubleshooting Procedures



WARNING

To avoid risk of electrical shock, personal injury or death, disconnect power to unit before servicing, unless testing requires power.

Titan LED Washer Control Board Inputs Table

Item	Description	Voltage	Input type	Input to Where	Comments
Water Valve Thermistor		0 - 3.3 VDC	Analog	Input to Micro-processor	
Power Cord	Line	120 VAC		Input to some relays	
	Neutral	120 VAC		Input to some relays	
	Ground	Chassis ground			
Lid Lock Switch	This switch senses if the lid is locked	0 - 12 VDC	Digital	Input to Micro-processor and safety circuitry	Closed when lid is locked
Lid Closed Switch	This switch senses if the lid is closed	0 - 12 VDC	Digital	Input to Micro-processor and system relay coil	Closed when lid is closed
User Interface	Membrane switch key pad	0 - 12 VDC	Digital	Input to Micro-processor	Open when key is not pressed
Tach from Variable Speed Motor Control	Tach signal	0 - 12 VDC	Digital	Input to Micro-processor and safety circuitry	
Pressure switch	Low water level	0 - 12 VDC	Digital	Input to Micro-processor	Closed when not satisfied
	Medium water level	0 - 12 VDC	Digital	Input to Micro-processor	Closed when not satisfied
	High water level	120 VAC		Input to Micro-processor and some relays	Closed when not satisfied

Membrane Pad Continuity Checks

Unplug ribbon connector from display board. Touch probe of meter to the appropriate pin numbers listed in the chart. Meter will show infinite unless the appropriate key is pressed.

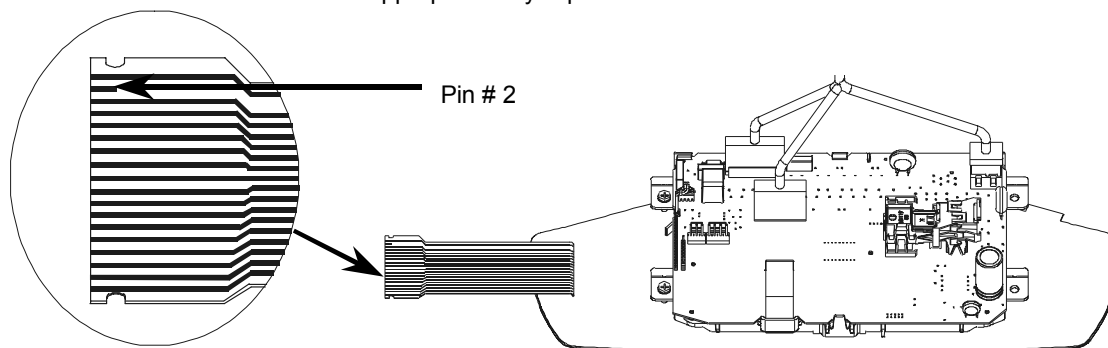

Button	Pin Number	Button	Pin Number
Super Wash	18 & 3	Start/Pause	6 & 4
Normal	5 & 3	Off	6 & 13
Wrinkle Control	6 & 3	Presoak	18 & 7
Delicates	18 & 12	Extra Rinse	18 & 13
Hand Wash	6 & 14	Signal -	18 & 4
Quick Wash	5 & 14	Signal +	6 & 7
Whites	18 & 14	Wash/ Rinse Temp	5 & 12
Colors/Jeans	6 & 12	Soil Level	5 & 13
Bulky Items	18 & 11	Spin	5 & 4
Enviro Plus	6 & 11	Delay Time Increase	5 & 7
Spin Only	5 & 11	Delay Time Decrease	6 & 8

Note: When the Neptune TL is plugged in, the Machine Control Board will check the lid latch mechanism every 20 seconds. If found to be locked with no cycle running, the Control Board will send a signal to the switch to unlock the lid.

Troubleshooting Procedures



WARNING

To avoid risk of electrical shock, personal injury or death, disconnect power to unit before servicing, unless testing requires power.

Trouble Shooting



WARNING

To avoid risk of electrical shock, personal injury, or death, disconnect power to washer before servicing, unless testing requires it.

Maytag Neptune™ TL FAV9800AW Washer

Diagnostic Code table follows later in this document.

Will Not Start

- Plug cord into live electrical outlet.
- Check fuse or reset circuit breaker to outlet.
- Close lid and push the START/PAUSE button to start washer. The START/PAUSE LED should change from flashing to on continuously.
- Check to see if the washer is in a pause or soak period of the cycle. Wait briefly for cycle to advance.
- Check for restricted drain system.
- Check the lid, lid latch mechanism, and circuitry. See **Will Not Lock**.

Leaking

- Make sure supply hose connections are not leaking. Check for rubber gasket damage due to over-tightening.
- Make sure end of drain hose is correctly inserted and secured to drain facility.
- Check bottom of tub around the pulley. See special instructions page 28.
- Check internal hose connections (fill & drain systems, hoses & clamps)
- Check tub cover. Remove, reposition and reinstall the tub cover seal. Seal seam must be at the top of the tub cover.
- Make sure water dispensing system on inner lid is securely attached to lid.
- Make sure dispenser valve is securely attached to mounting bracket.
- Check standpipe for leak. Wrap a dry rag around the standpipe opening. If rag becomes wet leak is fault of home plumbing. Be sure the standpipe is capable of accepting the flow of water from the washer.
- Check the lid hinges if water is coming out behind the lid.
- Check for bowing of lid where water enters detergent dispenser.

Display Lights Up When Lid is Opened or Closed

- This is normal behavior.

No Tumble

- Start normal cycle with an empty machine and allow a fill to check tumble.
- Fabric cycles such as NORMAL, DELICATES, HAND WASH, & WRINKLE CONTROL only tumble periodically, every 60 seconds.
- Check for loose connections at machine control board, motor control board and motor.
- Perform **Motor and Motor Control Test**.
- Washer does not tumble during most fills or during presoak.
- Washer with heat option does not tumble while heating.
- Check belt.

Will Not Spin

- During fill cycle – If machine tumbles and spins simultaneously replace clutch assembly.
- During spin cycle – If machine tumbles and spins simultaneously replace clutch assembly.
- Perform **Motor and Motor Control Test**.
- Check belt.
- Check that the machine control correctly senses all 3 water levels are empty. See **Board Input Test**.
- Tub Displacement Sensor disconnected, or loose wire.

No Water Fill

- Go to **No Fill Test**.
- Check to make sure water supply is turned on fully.
- Normal water level is 1 to 7 inches inside the spinner.
- Check electrical circuit and connections at the water valve, and pressure switch.
- Check for kinks in inlet hoses.
- Check for clogged inlet screens.
- Visually check hot and cold separately for fill.
- Check for low water pressure. May be dependent on pressure entering home. Variations may occur due to usage in the home at the time machine is used.
- Check for frozen pipes and hoses.

Tub Full of Suds

- Check for restricted drain system.
- Check for loose wire connections at control board and pump.
- Perform **Motor and Motor Control Test**.
- Use high efficiency or low sudsing detergent specially formulated for front load washers.
- Run the clothes washer through another complete cycle using the coldest water and no detergent.
- Reduce detergent amount for that specific load size and soil level. Towel loads have a minimal amount of soil present and typically create more suds.
- Check to see if belt is off motor and pulley.

Wet Clothes

- Very small clothes loads can cause unbalanced loads - add additional towels.
- Excessive suds may have been present.
- Check Tub Displacement Sensor connection and main harness connector at machine control board.
- Check Tub Displacement Sensor for 0 to 3.0 Volts DC output voltage between ground and the board input. Check for 12 Volts DC input voltage between the ground and the board output. Only check for voltage at the Tub Displacement Sensor. Do not perform a continuity check. See **Tub Displacement Diagnostics**
- Excessive motion was detected in spin Run **Quick Spin Test** with an empty tub to check Tub Displacement Sensor and machine control board.
- Check for restricted drain system.

Troubleshooting Procedures



WARNING

To avoid risk of electrical shock, personal injury or death, disconnect power to unit before servicing, unless testing requires power.

- Perform **Motor and Motor Control Test**. **Will Not Lock**
- Lid not all the way closed or not properly aligned.
- Check electrical connections at lock assemblies, machine control board, and Motor Control Board.
- Magnet missing. (Located on the back side of dispenser assembly inner lid, front Left corner).
- Laundry load is too large to close lid.
- Check system relay for welded contacts. (Diagnostic code 34) Disconnect power. Continuity between p.6 pin 1 to p.8. pin 1 at the Machine Control Board connector.
- Make sure inner lid is properly assembled to lid.
- Make sure door lock bumpers are fully seated to top cover.
- Go to **Lid Lock Test**.

Will Not Unlock

- Press **off**. The motor control is not responding if it takes 4 minutes to unlock. The motor control is either bad or disconnected.
- Unplug and reconnect power cord. Wait 20 seconds for machine to unlock.
- Check lid locked switch circuit. Circuit should be closed at machine control. (See **board input/output chart**).
- Check for loose electrical connections at lid lock and at machine control board.
- Push lid closed to make sure nothing from inside is pressing against it which may keep it from unlocking.
- Perform **Motor and Motor Control Test**. (see **Motor and Motor Control Test** section).
- If necessary, remove clothes by disconnecting power to washer, and open top cover with a putty knife.

Will Not Drain

- Check for restricted drain system.
- Check low, medium, and high water fill completion. Go to No Fill test.
- Check for 120 VAC at the pump when a spin cycle is selected < 550 rpm.
- Go to Board output test and perform Pump out test.
- In cold climates check for frozen Drain Hose.

Wrong Water Temperature

- Too Hot/Too Cold: This washer uses a reduced amount of water, while the control board meters the incoming flow to regulate the actual temperature of the water in the tub. This may appear to be significantly warmer/cooler than expected.
- Check that both faucets are on fully.
- Make sure the temperature selection is correct.
- This washer will compensate for reversed fill hoses. See **Hose Reversal Detection**.
- Make sure water heater is set to deliver a minimum of 120°F (49°C) hot water at the tap. Also check water heater capacity and recovery rate.
- If the water heater is located a long distance from washer, the water line may need to be purged prior to starting wash cycle.
- Disconnect inlet hoses and clean screens.

- The washer will need to go through a Hot / Cold cycle if the fill hoses were previously installed incorrectly and then corrected.
- Check Water Valve Thermistor. Resistance a room temperature is 61700 ohms. (See **board input/output chart**)

Noise / Cabinet Hits

- Level the machine
- Check sensor (refer to Tub Sensor Test).
- Check Strut and Strut Isolator for proper operation.
- Check for Diagnostic Code "10".

Removing A Favorite Cycle

If the consumer wants a favorite cycle removed, see below:

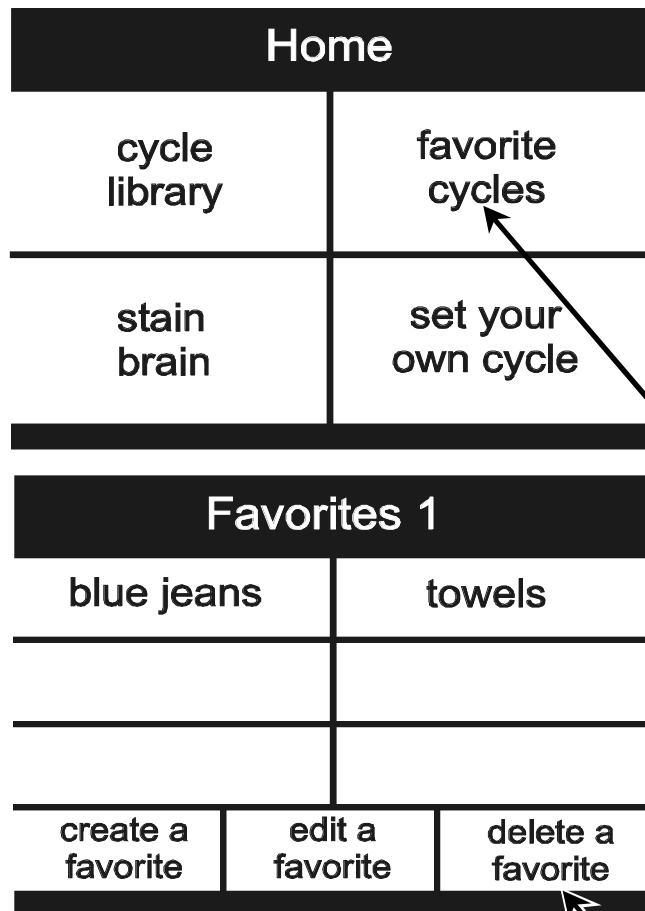

Service Mode

Service Mode enables service personnel to verify the operation of the washing machine and diagnose problems. Service Mode can be entered in the middle of any wash cycle without interrupting the cycle. While in Service Mode, the technician can cancel the current cycle, set a continuous running mode, start a variety of special service tests and view diagnostic displays.

Troubleshooting Procedures



WARNING

To avoid risk of electrical shock, personal injury or death, disconnect power to unit before servicing, unless testing requires power.

Enter / Exit Service Mode

To enter Service Mode press the **Help** and **Back** keys for three seconds or until the control beeps. The motor speed will be displayed when started (motor not running display will be 0). Diagnostic codes will be shown and the **System Check** or **Service** utility can be started. The present state of the machine will not be changed. (i.e., the current cycle in progress will not be interrupted and only the display will change).

Service Mode		DIAGNOSTIC CODE
service tests		
751	RPM	
system check	exit service	

To exit: 1) Press **exit service mode**, or 2) press **Off**, or 3) unplug the machine.

The following steps summarize special tests and features available in Service Mode, along with methods of activation and cancellation.

Accessing Service Tests and Diagnostic Features while in Service Mode.

Service Mode		DIAGNOSTIC CODE
service tests		
751	RPM	
system check	exit service	

User Interface

Enter User Interface and follow the directions on screen. This test will check the Membrane Pads and Touch Screen. The Membrane Pad and Touch Screen Test must be completed in approximately 10 seconds or a failure will be shown on the display.

Service Tests	
user interface test	service cycle
quick spin test	advance to next step
system check	exit service tests

Quick Spin Test

While in Service Mode, select the **Quick Spin Test** option.

Quick Spin test steps are as follows:

- 1) Lock the lid.
- 2) Spin to index speed 90 rpm and hold for 60 seconds. Pump drains machine.
- 3) Spin to index speed 150 rpm and hold for 6 seconds.
- 4) Spin to index speed 350 rpm and hold for 6 seconds.
- 5) Spin to index speed 550 rpm and hold for 6 seconds.
- 6) Spin to index speed 700 rpm and hold for 6 seconds.
- 7) Spin to index speed 850 rpm and hold for 6 seconds.
- 8) Spin to index speed 1000 rpm and hold for 6 seconds.
- 9) Coast down to 0 rpm.
- 10) Unlock lid.

Service Tests	
user interface test	service cycle
quick spin test	advance to next step
system check	exit service tests

Troubleshooting Procedures

⚠ WARNING

To avoid risk of electrical shock, personal injury or death, disconnect power to unit before servicing, unless testing requires power.

Hold Quick Spin Test

If the **Hold at this step** option is selected during the Quick Spin test, the machine will hold at the next highest index speed for up to 30 minutes.

Quick Spin Test	
350 RPM	
Hold at this step	
Cancel & return to "Service Tests"	

System Check

Select the desired output to test. The system relay must be on to test components. The highlighted area indicates the state of each output.

Service Tests	
user interface test	service cycle
quick spin test	advance to next step
system check	exit service tests

System Check		
OUTPUTS		INPUT STATUS
Syst. Rly. on off	motor ctrl. on off	lid closed lid unlocked no unbalance low fill empty medium fill empty high fill empty fill tmp. (°F) <70 sump tmp. (°F) 16 RPM 775
hot on off	cold on off	
bleach on off	fab. soft. on off	
drain on off	heater on off	
pulse lid lock	pulse lid unlock	

Note: When the Neptune TL is plugged in, the Machine Control Board will check the lid latch mechanism every 20 seconds. If found to be locked with no cycle running, the Control Board will send a signal to the switch to unlock the lid.

If motor does not run; Check for 120 VAC at the motor control board harness between L1 and Neutral. **See Illustration**



If voltage is present, then problem exists with the motor and motor control system.

- Check for loose electrical connections at motor, and motor control board.
- Check phase windings of the motor. **See Illustration.** If motor windings are good, replace the motor control board.

Diagram - Motor Harness

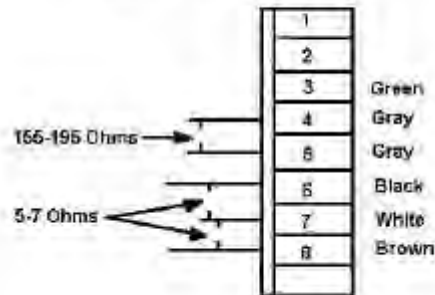

If voltage is not present;

- Check for loose electrical connections at Machine Control Board or broken wires in harness.

Troubleshooting Procedures



WARNING

To avoid risk of electrical shock, personal injury or death, disconnect power to unit before servicing, unless testing requires power.

Service Cycle

This will be a quick check of all systems.

1. Lid locks.
2. Press **Start\Pause**.
3. Lid unlocks.
4. **Open lid**.
5. **Close lid**.
6. Press **Start\Pause**.
7. Lid locks.
8. Cold water bleach fill.
9. Bleach fill. **Advance to next step if water is not connected to machine.**
10. Tumble using 48 rpm tumble for 10 seconds.
11. Hot fill.
12. Fabric softener fill. **Advance to next step if water is not connected to machine.**
13. Drain.
14. Spin to 150 rpm.
15. Spin to 350 rpm.
16. Spin to 850 rpm.
17. Pump cycles on and off.
18. Coast to 0 rpm.
19. Lid unlocks.

Service Tests

user interface test	service cycle
quick spin test	advance to next step
system check	exit service tests

If a failure occurs during the test, an error screen will appear. Select OK to continue. The test will continue depending on the nature of the failure.

Display Diagnostic Codes

Enter **Service Mode** to display diagnostic codes. Diagnostic codes will be shown in the right pane as shown.

Service Mode

service tests	DIAGNOSTIC CODE
751 RPM	
system check	exit service

Access Other Features

To view details about the software version and the total cycle count, select the diagnostic code portion of the screen. You will also be able to view details about the number of cycles since a diagnostic code occurred, if a code is logged.

Diagnostic Codes vers.: TWL_____
cycle count 70000 flash: TWL_____

8-W. Level fault 65520 cycles ago
10-Low RPM unbal 65524 cycles ago
40-Wedged load 65527 cycles ago

clear diagnostic codes	exit diagnostic codes
------------------------	-----------------------

Diagnostic Codes

Diag. Code	Description	Trigger	Action to be taken
1	No Drain	The water level fails to drop below the Low level before a spin	Go to " Will Not Drain " Troubleshooting Section
2	The lid fails to unlock	Lid failed to unlock after multiple attempts	Go to " Will Not Unlock " Troubleshooting Section
3	No Fill	Total fill 14 minutes exceeded.	Go to " No Water Fill " Troubleshooting Section
4	The lid fails to lock	Lid failed to lock after 11 attempts	Go to " Will not unlock " Troubleshooting Section

Troubleshooting Procedures



WARNING

To avoid risk of electrical shock, personal injury or death, disconnect power to unit before servicing, unless testing requires power.

Diagnostic Codes

Diag. Code	Description	Trigger	Action to be taken
5	Continuous unbalanced circuit. Out of balance circuit	See section for unbal. loads. (During spin only)	Go to " Wet Clothes " Troubleshooting Section
6	Locked Rotor forcing a shut down.	Locked rotor is still locked after 10 attempts.	Go to " Motor Control Board Output Test "
8	Water level sensor fault.	Higher water levels were sensed while the lower water levels were not.	Go to " No Water Fill Test "
10	Unbalance or cabinet hit detected during final spin, which prevented the spinner from exceeding 500 rpm	Less than 500 rpm due to an unbalanced load.	Go to " Wet Clothes " Troubleshooting Section"
11	Will not remember machine settings	Difficulty in reading memory	Go to " Clear diagnostic codes " Disconnect and reconnect the washer power cord at power supply outlet. If condition still exists, replace machine control board.
15	Stuck Key	Detected a key pressed more than 75 seconds. The key is assumed to be stuck.	Go to " Membrane Pad Check " Check connection of keypad to control board. Replace console if necessary.
16	High speed not achieved due to torque.	Speed less than 400 rpm during a main wash cycle.	Go to " Wet Clothes " Troubleshooting Section"
17	The lid was not opened after completed wash cycles.	Did not sense lid open after the last three completed cycles.	Customer may have tried to repeat wash cycle without opening the lid. Go to " Lid Lock Test "

Diag. Code	Description	Trigger	Action to be taken
18	Detected lid lock switch open during cycle when not expected.	Open lid lock switch with motor running.	Check for loose wire connections. Clear the diagnostic code and recheck; if reoccurs, perform Diagnostic Motor/Motor Control Board test Check for faulty motor relay on the machine control board.
22	Detected lid switch open during cycle (when not paused).	Detected lid sensor switch open and the lid locked switch locked.	Go to " Lid Lock Test " Troubleshooting Section
23	Lid is locked at start of cycle	Lid lock is locked and a user tries to start a cycle.	Go to " Will Not Unlock " Troubleshooting Section
24	Motor high RPM detected two times	Motor tach signal is seen at maximum speed.	Replace motor control board.
25	Motor tach signal exists without motor running	Tach signal exists without torque input. (Abnormal condition only)	Replace motor control board.
28	Water valve thermistor failure	Abnormal high/low temp or ohm resistance seen	Go to " Wrong Water Temperature " Troubleshooting Section
34	Welded system relay	Change of state of the relay	Disconnect power. Continuity between p.6 pin 1 to p.8. pin 1 at the Machine Control Board connector.
40	Washer not operating due to tumble not functioning	Load bound up.	The washer is unable to complete its cycle. The paddles cannot move. To continue, separate and redistribute the load, then press "start/pause".

Exit Service Mode

To exit: 1) Press **exit service mode**, or 2) press **Off**, or 3) unplug the machine.

After five (5) minutes of inactivity (user key presses) in Service Mode, the machine will exit the Service Mode

Troubleshooting Procedures



WARNING

To avoid risk of electrical shock, personal injury or death, disconnect power to unit before servicing, unless testing requires power.

and resume normal operations. Pressing the Off key will completely exit Service Mode. If a cycle is running, cancel the cycle. Pressing the Start/Pause key while running a test will pause the individual test, while remaining in Service Mode. A power loss during Service Mode will cancel this mode.

Hose Reversal Detection and Correction

The washing machine has diagnostic features that determine if the hoses are reversed on the first complete cycle after power up. The control board monitors water temperatures during the wash cycle.

The control system is capable of detecting hot and cold water intake hose reversal and will change the fill temperature as necessary after the first cycle. The control system stores and retains hot and cold water intake hose reversal information through a power-down.

The system reverts to factory defaults for the cold and hot water valves and cancels hose reversal detection if a diagnostic code 28 has been logged in a cycle. See **“Wrong Water Temperature”** in the troubleshooting tips, at the beginning of this document for more information.

Torque Specifications

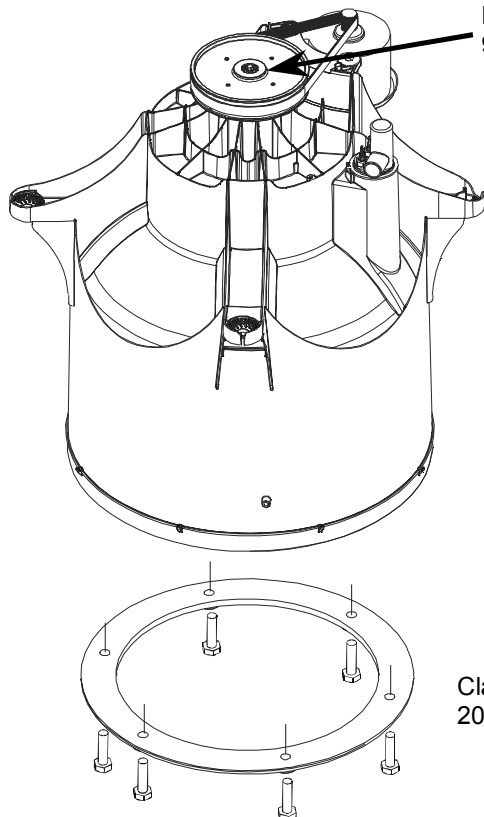

Pulley clutch Bolt
96 in. lbs.

Clamp Ring 15-
20 ft. lbs.

Spinner Support Shaft Nut 64-80 ft. lbs. Special wrench required.

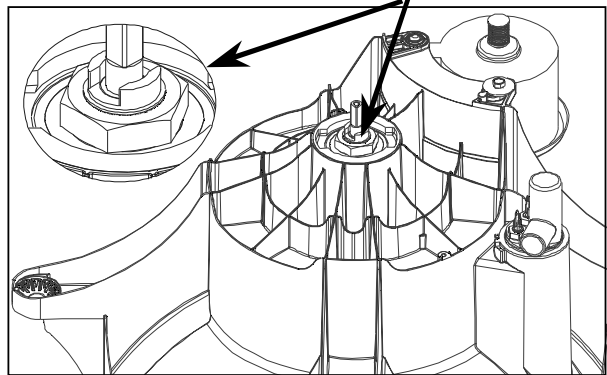

Tube Displacement Sensor Diagnostics

CAUTION: Do not perform continuity check directly on Displacement Sensor due to the potential for damaging the microprocessor chip in the sensor.

1. Enter the Service Mode by pressing the **Help** and **Back** keys for three seconds.
2. Press **System Check** on the display
3. Push tub to back right corner so sensor extends beyond the #2 mark molded on slider. Display will show **“tub unbalance”**.

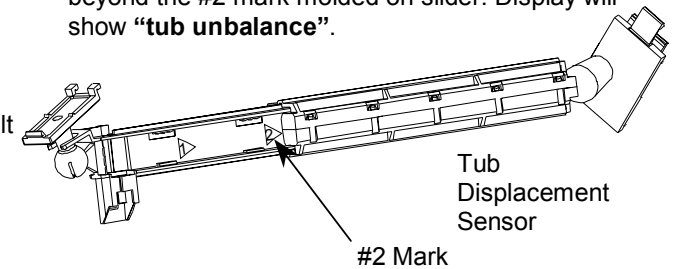

4. Pull tub to front left corner and push down so sensor collapses to before the #1 mark molded on slider. Display will show **“tub unbalance”**.

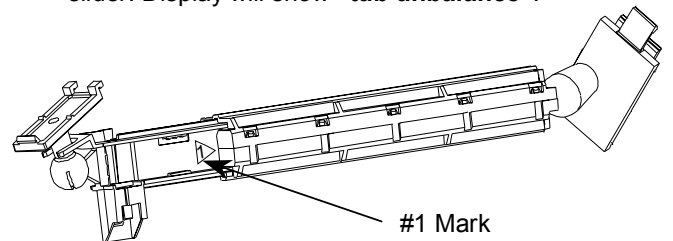

NOTE: Moving the tube midway between mark #1 and mark #2 represents normal operation. Display will show **“no unbalance”**.

Troubleshooting Procedures



WARNING

To avoid risk of electrical shock, personal injury or death, disconnect power to unit before servicing, unless testing requires power.

Component Diagnostics

NOTE: Unplug lower harness connector under console and test from wire insertion side.

Component Check	Pin	Wire Color	Range
Drain Pump	2 and 11	WH and RD/BK	0 to 30 Ohms
Pressure Switch Low Level	4 and 13	BR and RD/W H	0 to 20 Ohms (no water in machine)
Pressure Switch Med Level	13 and 14	PU and RD/W H	0 to 20 Ohms (no water in machine)
Pressure Switch High Level	1 and 9	GY/BK and YL/BL	0 to 20 Ohms (no water in machine)

Special Instructions Water Leak Around Pulley On Tub Bottom

Water leaking around the pulley on the bottom of the tub, check the following:

1. Remove the Transmission. The Transmission should be approx. 1/3 full of oil. The oil in the Transmission should be thick, similar to a high viscosity motor oil. Tip the Transmission slightly, the oil should move slowly. If the Transmission is nearly full or if the fluid is very thin and moves quickly, the Transmission has water in it. Replace the Transmission, O-Ring, Spinner Support, Tub Seal and Outer Tub.
2. If no water is inside the Transmission, check the integrity of the O-Ring. Look for signs of water or rust on and around the Input Shaft. If the O-Ring is bad or there are signs of water or rust around the input shaft, replace the spinner support, tub seal and the outer tub.
3. If there was no water in the Transmission or around the top of the Input Shaft, it is likely the water was leaking through the Tub Seal. Replace the Outer Tub and Tub Seal. Inspect the Spinner Support for damage around the Tub Seal area. Replace the Spinner Support if it is damaged.
4. The Clutch Assembly should be inspected for signs of water or oil contamination. Clean Clutch Assembly as needed. Replace Clutch Assembly when water or oil contaminates the roller clutches.

Note: Oil in a new Transmission is clear. During operation, the oil will turn a dark color caused by the special compounds in some of the bushings.

Insertion Side Lower Harness Connector

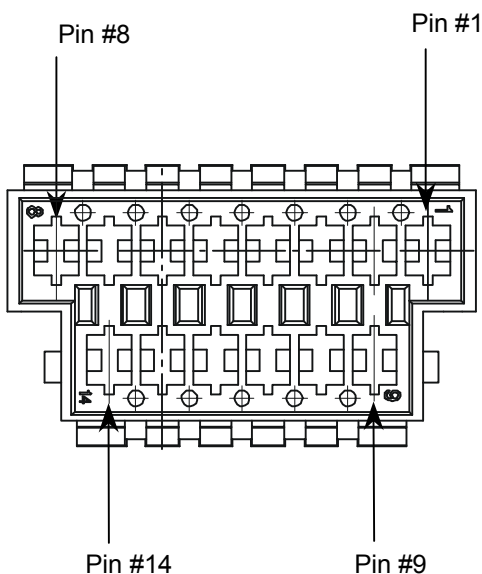

Troubleshooting Procedures



WARNING

To avoid risk of electrical shock, personal injury or death, disconnect power to unit before servicing, unless testing requires power.

Titan LED Washer Control Board Inputs Table

Item	Description	Voltage	Input type	Input to Where	Comments
Water Valve Thermistor		0 - 3.3 VDC	Analog	Input to Micro-processor	
Power Cord	Line	120 VAC		Input to some relays	
	Neutral	120 VAC		Input to some relays	
	Ground	Chassis ground			
Lid Lock Switch	This switch senses if the lid is locked	0 - 12 VDC	Digital	Input to Micro-processor and safety circuitry	Closed when lid is locked
Lid Closed Switch	This switch senses if the lid is closed	0 - 12 VDC	Digital	Input to Micro-processor and system relay coil	Closed when lid is closed
User Interface	Membrane switch key pad	0 - 12 VDC	Digital	Input to Micro-processor	Open when key is not pressed
Tach from Variable Speed Motor Control	Tach signal	0 - 12 VDC	Digital	Input to Micro-processor and safety circuitry	
Pressure switch	Low water level	0 - 12 VDC	Digital	Input to Micro-processor	Closed when not satisfied
	Medium water level	0 - 12 VDC	Digital	Input to Micro-processor	Closed when not satisfied
	High water level	120 VAC		Input to Micro-processor and some relays	Closed when not satisfied

Membrane Pad Continuity Checks

Unplug ribbon connector from display board. Touch probe of meter to the appropriate pin numbers listed in the chart. Meter will show infinite unless the appropriate key is pressed.

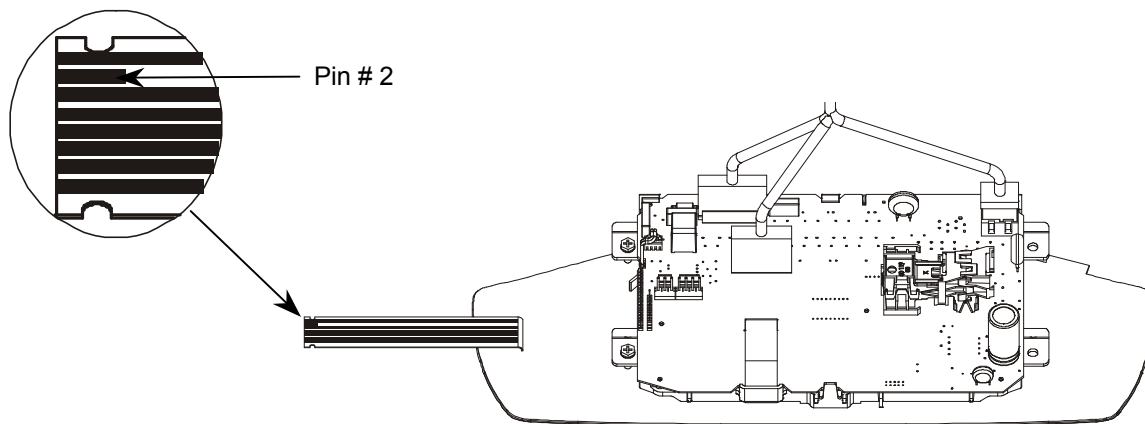

Button	Pin Number
Home	5 & 3
Favorites	6 & 3
Back	5 & 4
Off	5 & 7
Start/Pause	6 & 7
Help	6 & 4
Stain Brain	5 & 8
Cycle Library	6 & 8

Disassembly Procedures



WARNING

To avoid risk of electrical shock, personal injury or death; disconnect power to unit before servicing.

Console Removal

1. Disconnect power supply to unit.
2. Remove 3 T-15 Torx screws from back Console Cover.
3. Separate Back Panel from Console.



4. Press the right side of the console and slightly rotate forward to disengage the two side hooks; the back panel may need to be held away from the console. Slide the entire console to the right to remove.

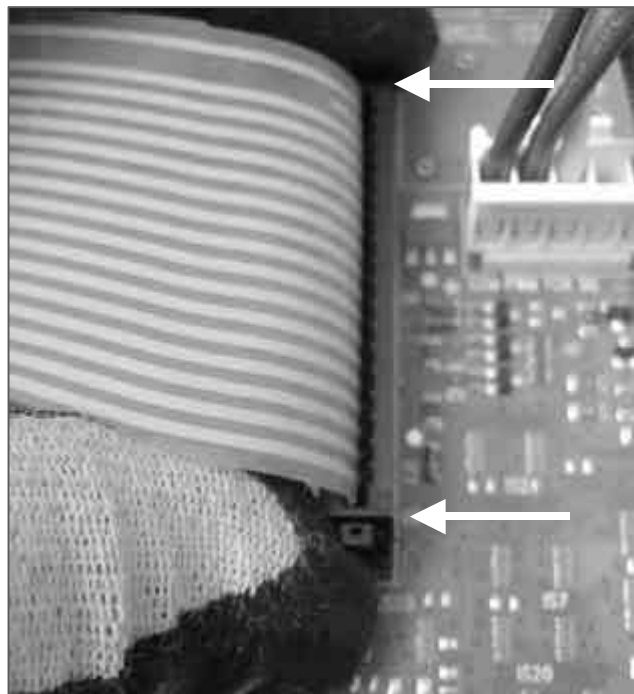
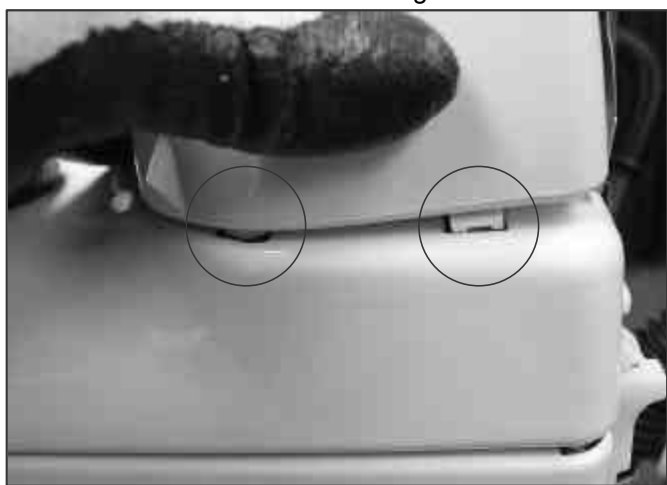

5. Lift ribbon out of connector.

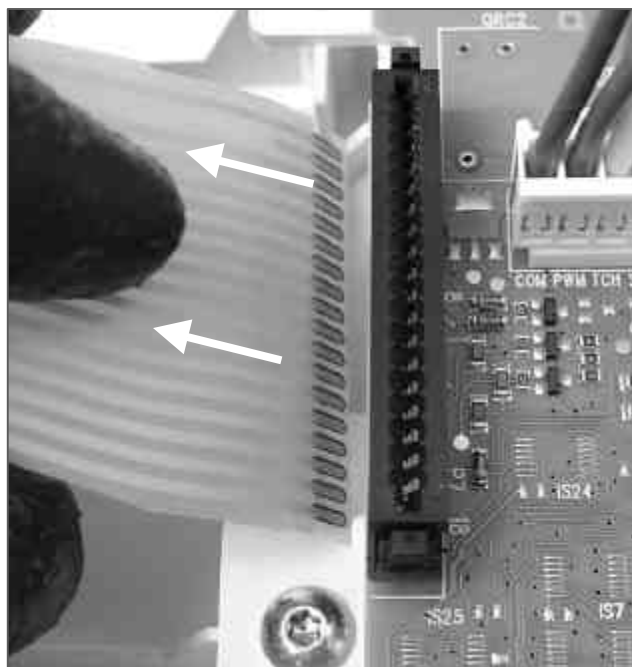

Control Board Removal

1. Disconnect power supply to unit.
2. Remove Console.
3. Separate Back Panel from Console.
4. Pull up on side lock tabs of Ribbon Connector.

Disassembly Procedures



WARNING

To avoid risk of electrical shock, personal injury or death; disconnect power to unit before servicing.

6. Disconnect the remaining harness connectors.

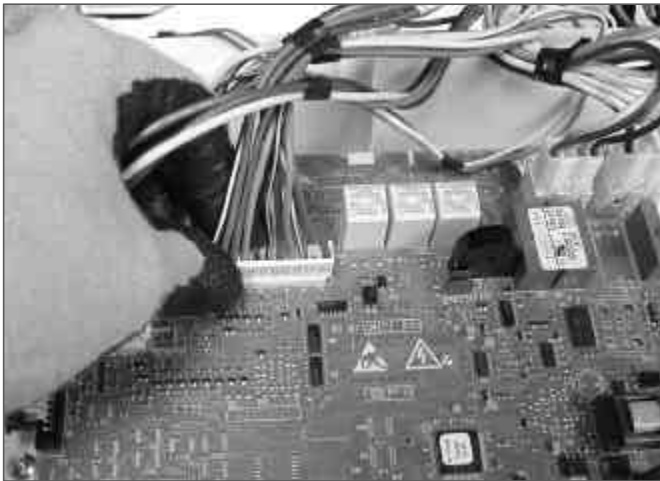

7. Remove two T-15 Torx screws, attaching Control Board to Console.

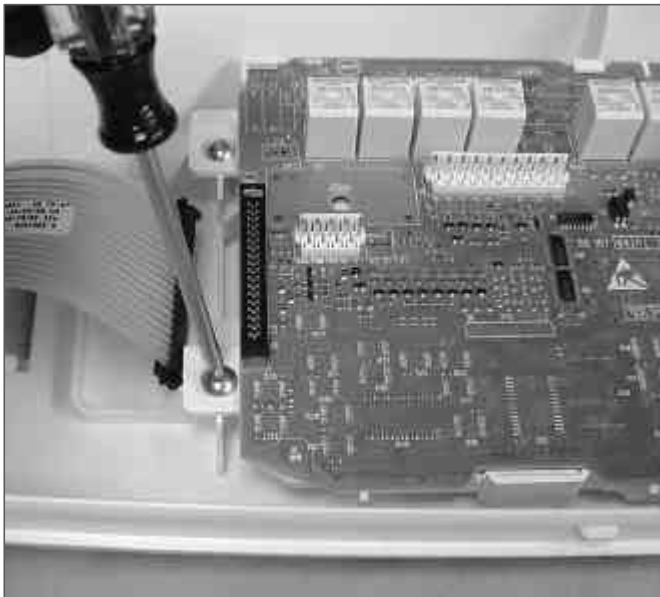

8. Slide Control Board up and to the left to disengage tabs locking the right side in place.

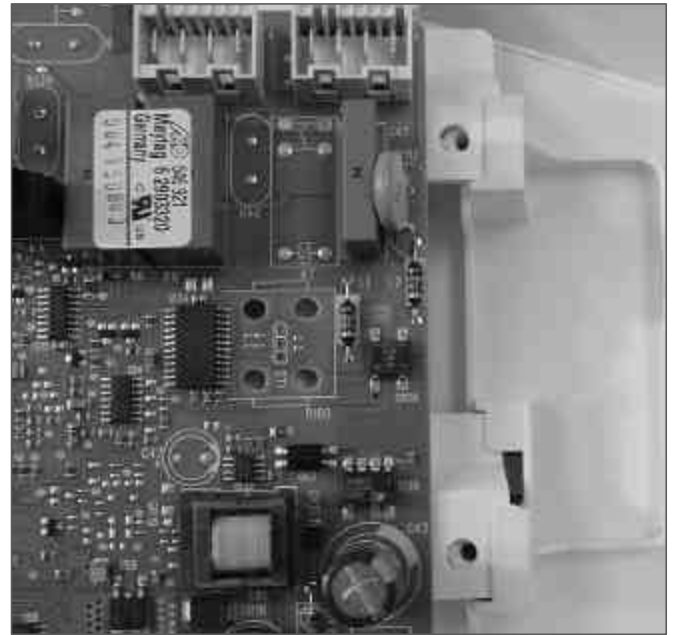

9. Main Wiring Harness Separates at plug, allowing Console to be completely removed.

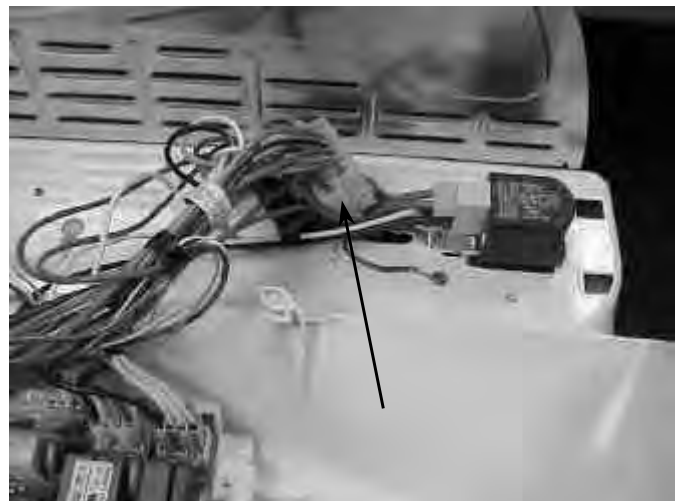

Disassembly Procedures



WARNING

To avoid risk of electrical shock, personal injury or death; disconnect power to unit before servicing.

Lid Disassembly/Removal

1. Disconnect power supply to unit.
2. Remove Detergent Dispenser by inserting a quarter to release catch. Pull Dispenser out and down.

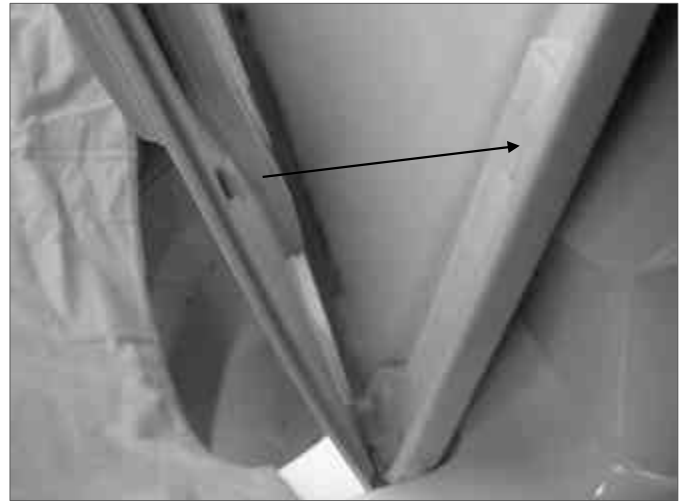

3. Remove Inner panel, by pulling the bottom out on the left and right sides. The dart molded in the Inner Panel will disengage from the Outer Lid.

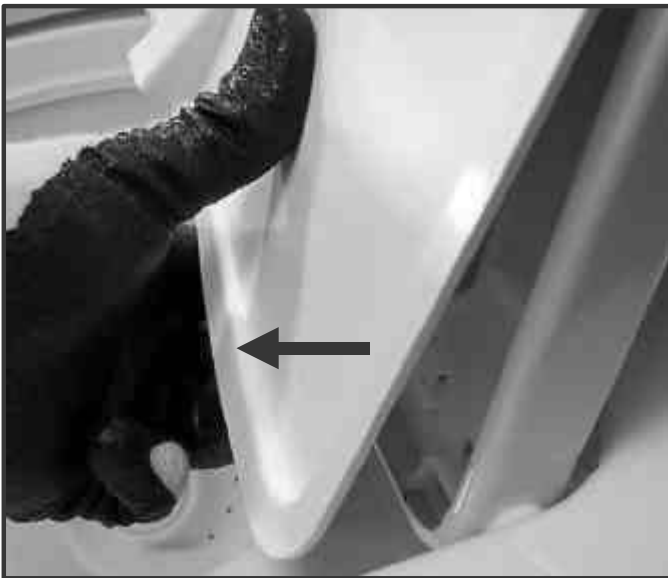

5. Remove Outer Lid by releasing catch in back corner on either side.

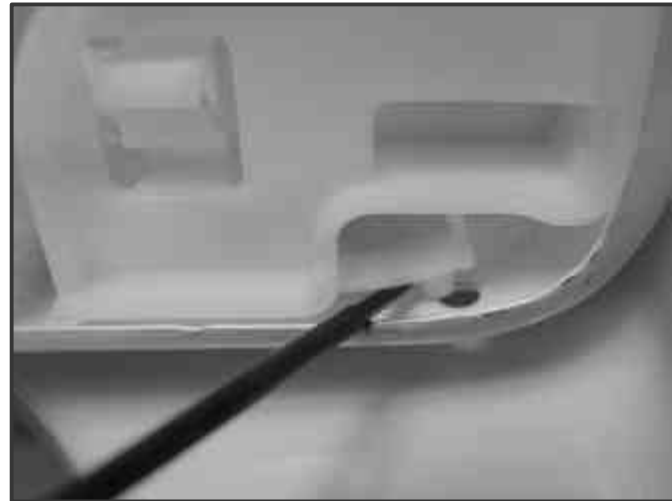

6. Separate hinge from Outer Lid. Slide lid to side, and remove.



4. Slide panel down, to disengage tabs and release Inner Panel.

Disassembly Procedures

WARNING

To avoid risk of electrical shock, personal injury or death; disconnect power to unit before servicing.

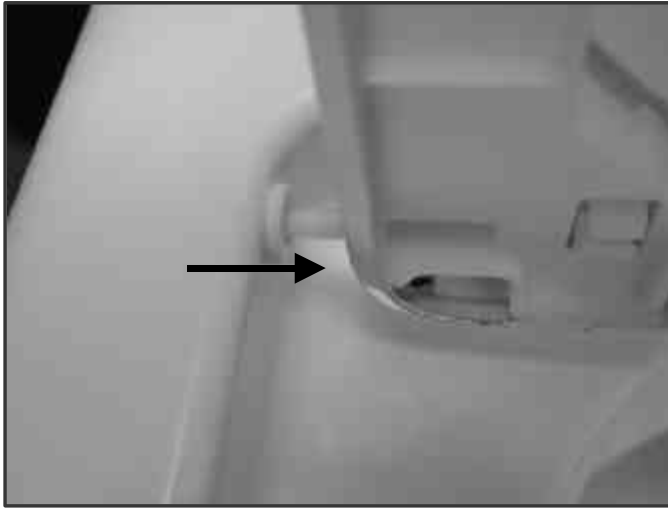

Top Cover Removal

1. Disconnect power supply to unit.
2. Insert a plastic putty knife in line with the lid seam and push in to release catches on the left and right side. Top cover is hinged at the rear.

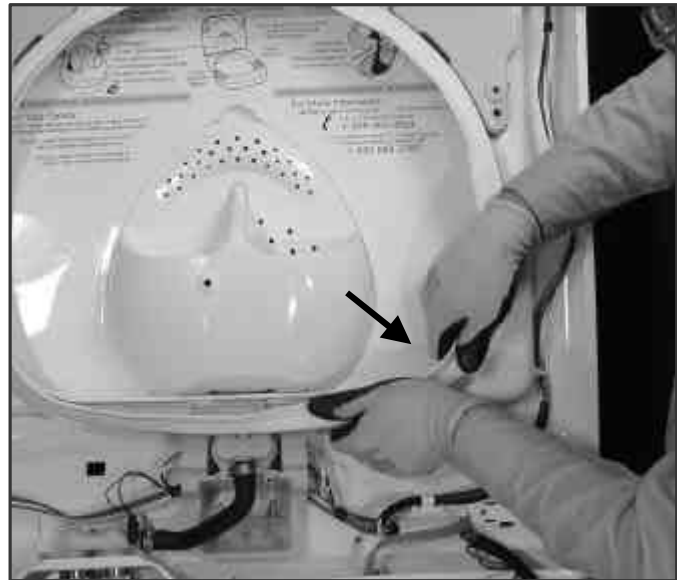

Bleach/Softener Dispenser Removal

1. Disconnect power supply to unit.
2. Lift lid, and with a putty knife pry on long side of the triangle to release the cover from tabs underneath.

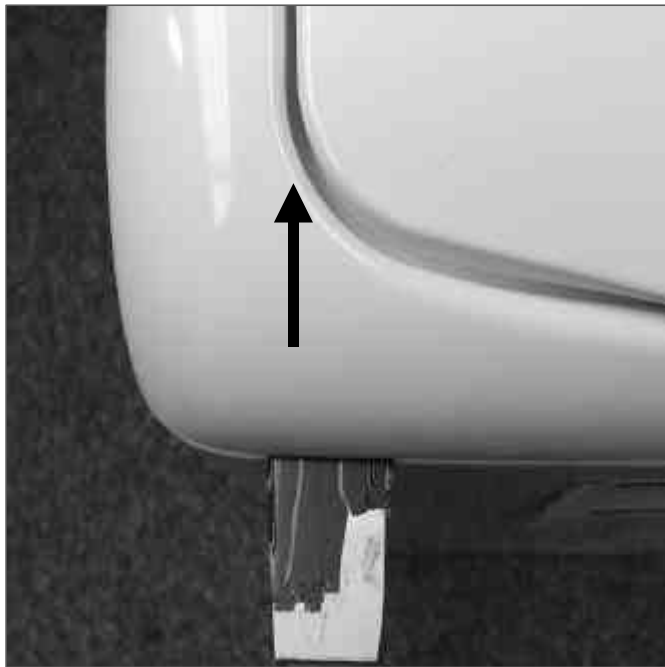

Splash Guard Removal

1. Disconnect power supply to unit.
2. Lift Top Cover.
3. Unsnap Splash Guard by starting in the lower right corner and working around perimeter until guard is free.

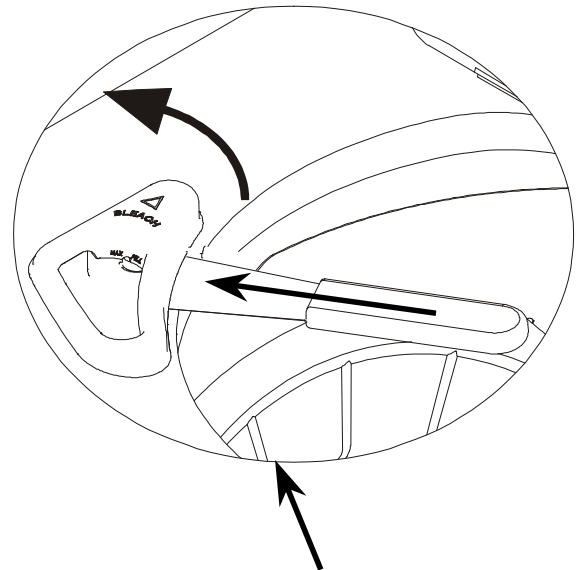

Push in direction of arrow while lifting and rotating cover up.

3. Reinstall cover by placing onto tabs at point of triangle. Then rotate down and snap into place across the long side of the triangle while pushing up on the reservoir underneath.

Disassembly Procedures

WARNING

To avoid risk of electrical shock, personal injury or death; disconnect power to unit before servicing.

4. Remove Dispenser Housing by lifting Top Cover.
5. Depress Housing wall to release catch from Top Cover.

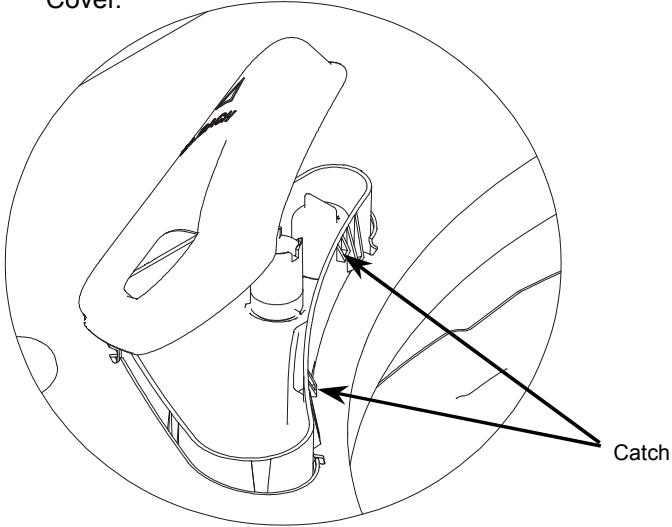

6. Pull Housing away from Top Cover.

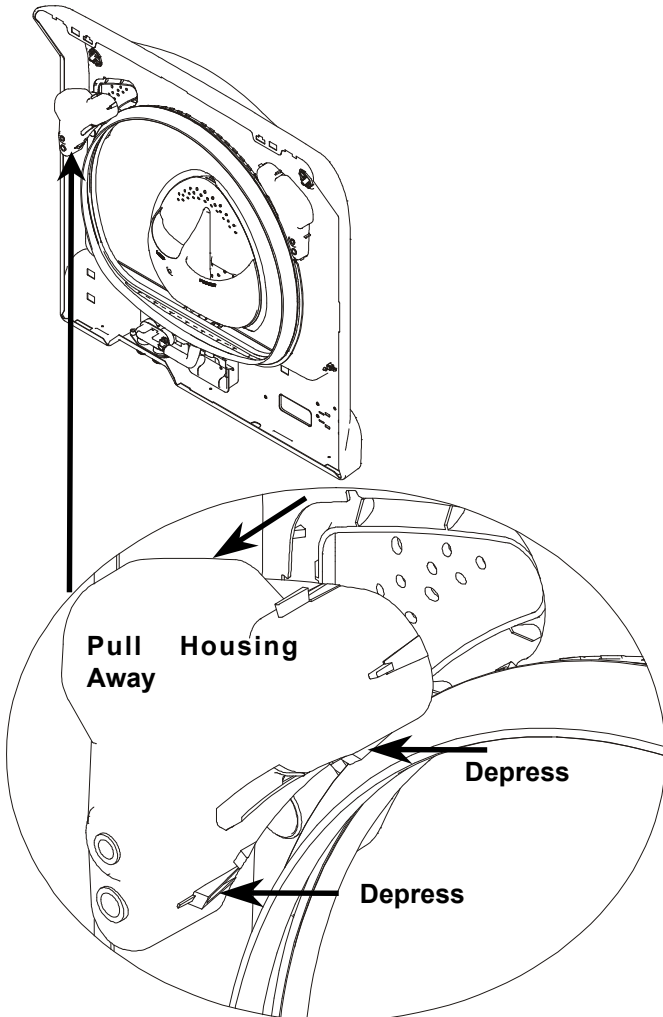

Lid Lock/Reed Switch Removal

1. Disconnect power supply to unit.
2. Lift Top Cover.
3. Disconnect wiring harness to Lid Lock.



4. Remove 1/4" Hex screw attaching Lid Lock to Top Cover.



5. Repeat procedure for Lid Lock on right side.
6. The left Lid Lock is a combination lock and Reed Switch. Access the magnet by lifting the lid and removing the Inner Lid.

Disassembly Procedures



WARNING

To avoid risk of electrical shock, personal injury or death; disconnect power to unit before servicing.

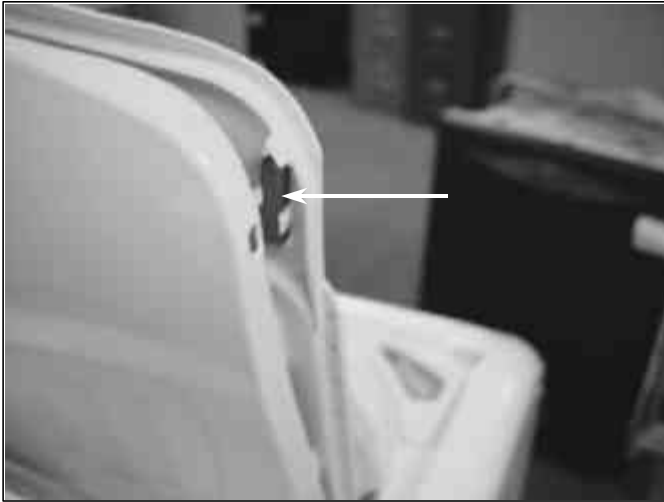

Inlet Water Valve Removal

1. Disconnect power supply to unit.
2. Remove water lines to the back of washer.



3. Lift Top Cover.
4. Remove wire harness from Water Valve.



5. Remove screw attaching Water Valve to Top Cover.



7. Pry up on the right side vapor seal flange while sliding the valve to the right to release it from the top cover.

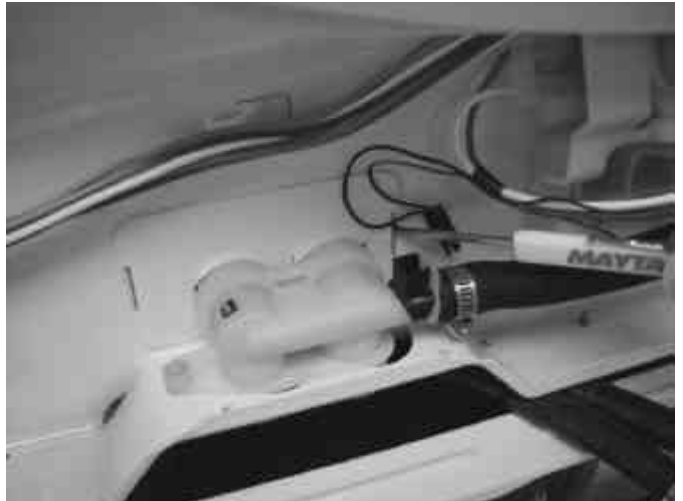

8. Slide Water Valve to the right to release from Top Cover.



Disassembly Procedures



To avoid risk of electrical shock, personal injury or death; disconnect power to unit before servicing.

9. Remove wire harness from valve right and left solenoid.

10. Remove hose clamp.



11. Vapor Shield slides off Water Valve.

NOTE: When replacing Water Valve grease terminal according to instructions. Grease is provided with kit.

4. Remove screw attaching valve assembly to Top Cover.



5. Remove hose clamp.

NOTE: Reattach hose clamp with screw head facing the water valve assembly.

6. Remove screw attaching valve to housing.

Detergent Dispenser Water Valve Removal

1. Disconnect power supply to unit.
2. Lift Top Cover.
3. Remove wire harness from left and right side of valve.



Disassembly Procedures



WARNING

To avoid risk of electrical shock, personal injury or death; disconnect power to unit before servicing.

Tub Cover Removal

1. Disconnect power supply to unit.
2. Lift Top Cover.
4. Press down on Tub Cover while lifting up on latches.

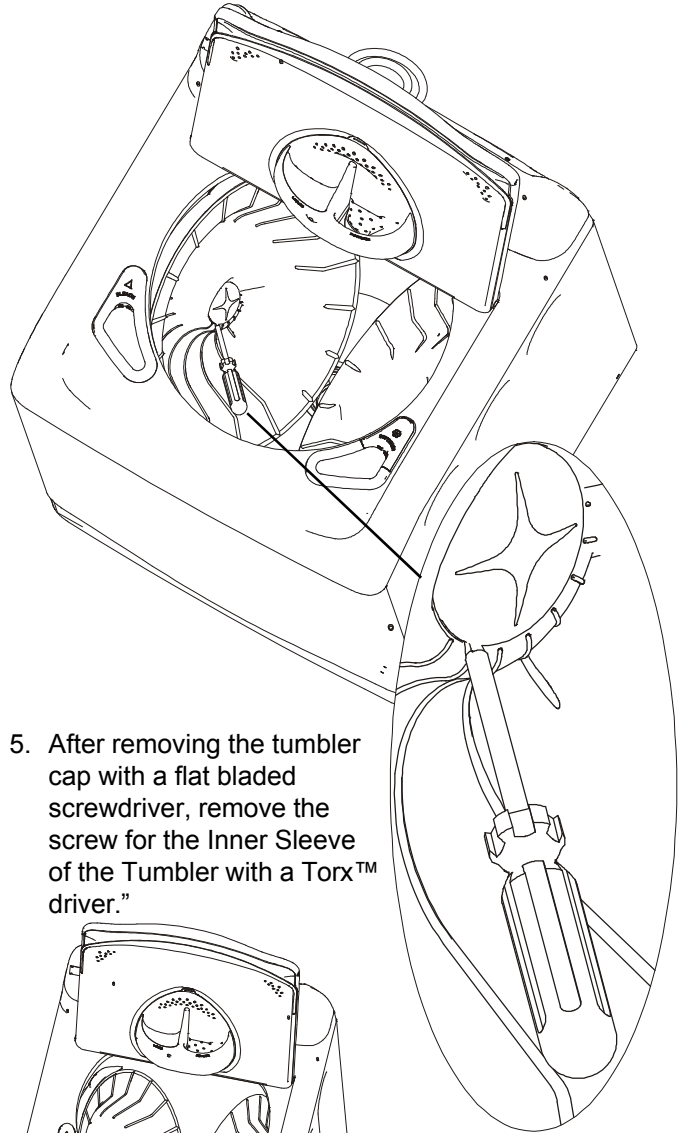

Tumbler Removal

1. Disconnect power supply to unit.
2. Lift lid.
3. Rotate inner tub until arrow formed in Stainless Steel points to the back of the machine.

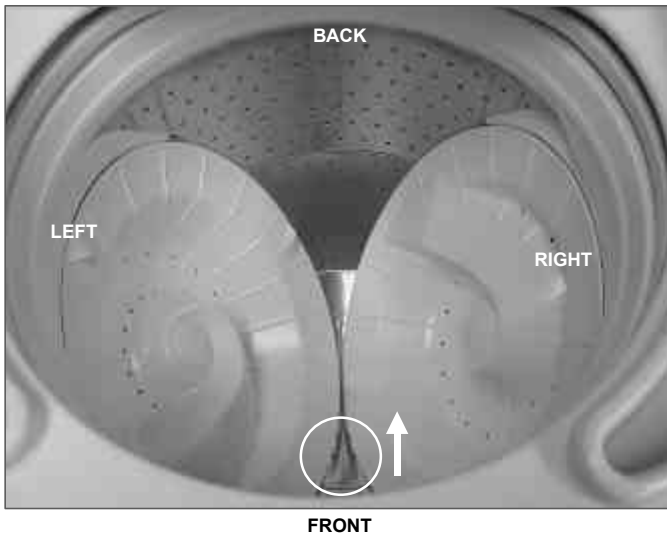

5. After removing the tumbler cap with a flat bladed screwdriver, remove the screw for the Inner Sleeve of the Tumbler with a Torx™ driver.”

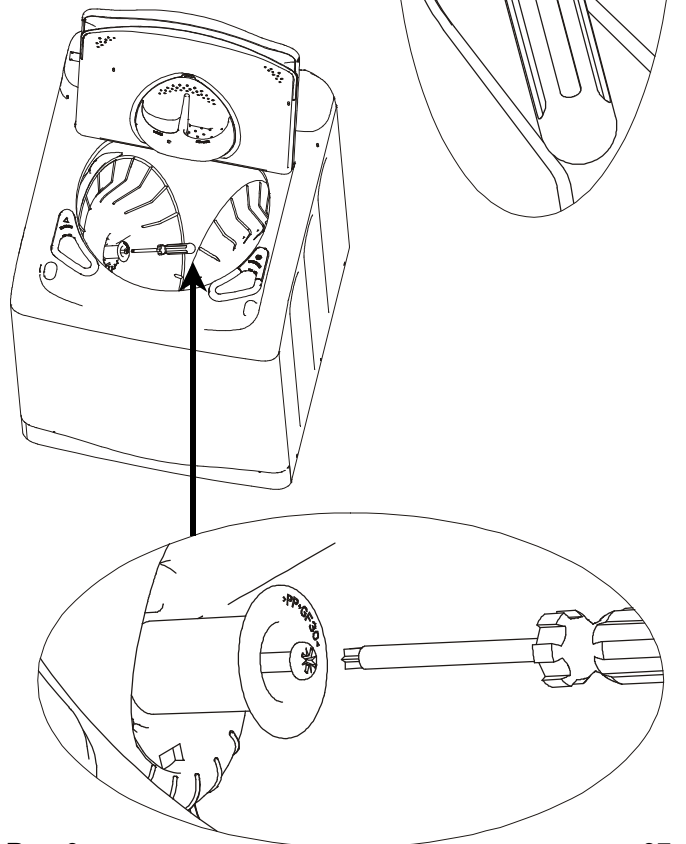

4. Remove Tumbler Cap with a flat blade screwdriver. Do not mar or create a burr on the Tumbler, or Tumbler Cap, which could snag clothes.

Disassembly Procedures

WARNING

To avoid risk of electrical shock, personal injury or death; disconnect power to unit before servicing.

6. Tip Tumbler Assembly forward and pull up to remove. Tumbler Assembly may need to be rocked back and forth to free it from bearing surface.

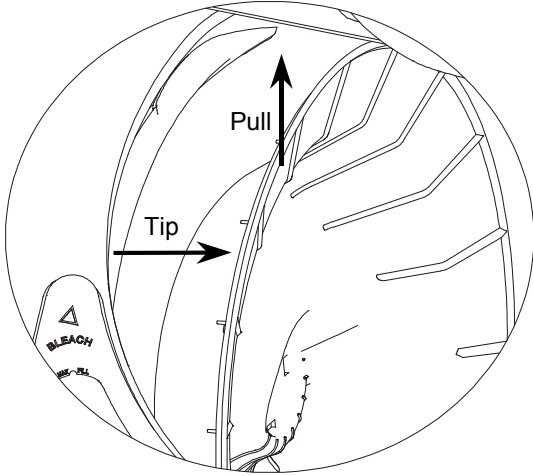

NOTE: When sliding Tumbler past Balance Ring on spinner, orient the Tumbler upside down to reduce the risk of marring the Balance Ring.



During reassembly orient the Tumbler facing up.

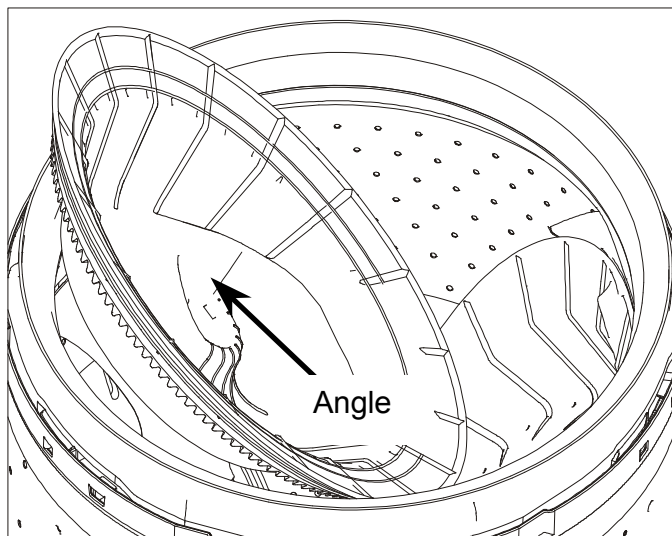

IMPORTANT: Right and left Tumbler Assemblies are not the same, and should not be reversed. Identify the correct Tumbler by looking at the back for an “L” or “R” molded into the plastic. The Tumbler Assemblies also have timing marks that must be aligned for proper operation. Rotate the Tumbler by hand to align the timing marks at the bottom of the Tumbler revolution as shown.

7. Reinstall Tumbler Assembly in reverse of disassembly by setting bottom edge in place first, and rotating back into position. The Tumbler, when properly seated will “POP” into place.

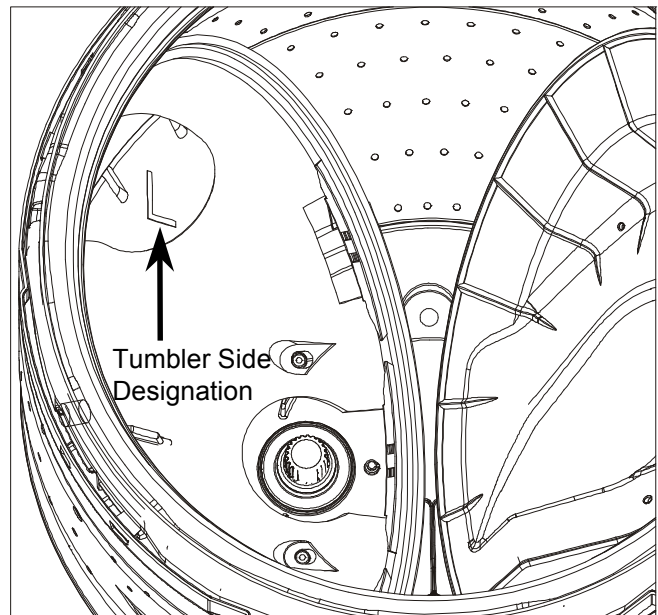
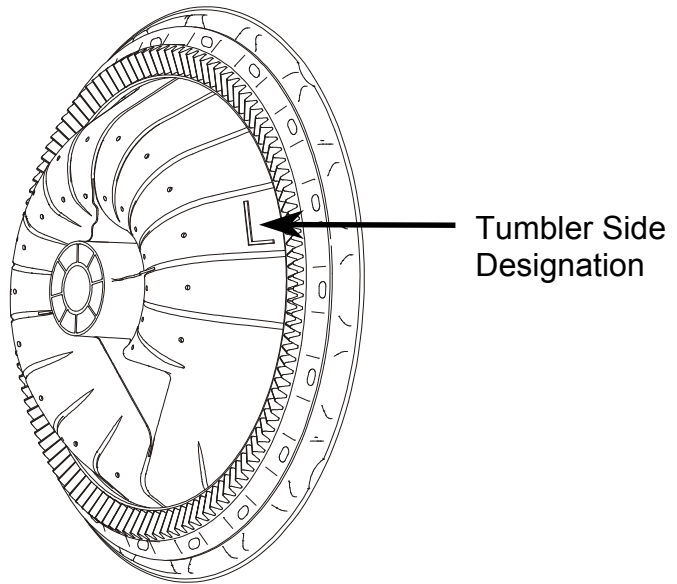

IMPORTANT: The spinner also has “L” and “R” molded into the plastic under the tumbler. Insure the correct tumbler is used for the corresponding side of the spinner.

Disassembly Procedures

WARNING

To avoid risk of electrical shock, personal injury or death; disconnect power to unit before servicing.

NOTE: Teeth On Journal Lock Into The Tumbler To Prevent Rotation.

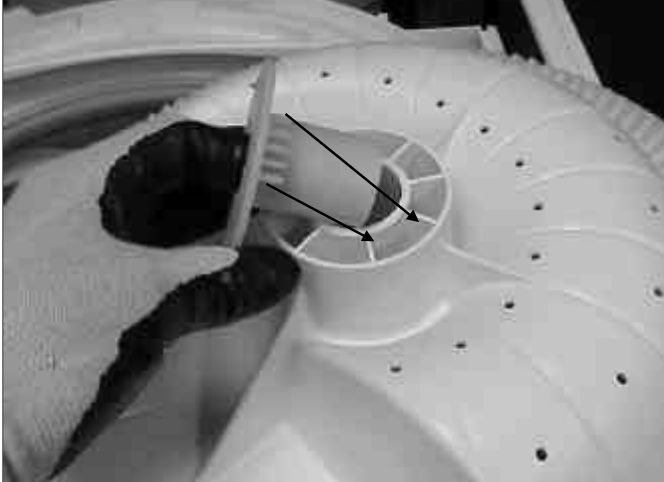

Note: Arrow Direction for the Left and Right Timing Marks. The point of the triangle on the right Tumbler must align between the 2 points of the left Tumbler along the base of the triangle. Any other configuration such as the two flat sides aligned, or the points of the triangle facing each other, indicates two left or right side Tumblers. Replace one of the Tumblers. Identify left and right Tumbler location by the “L” and “R” visible in the bottom of the Spinner when the Tumbler is removed.

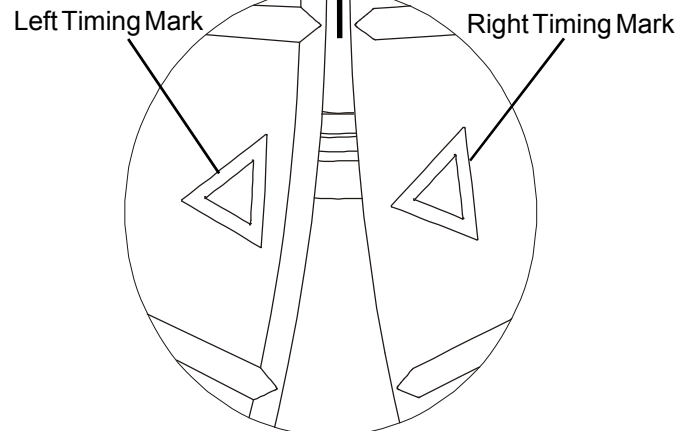
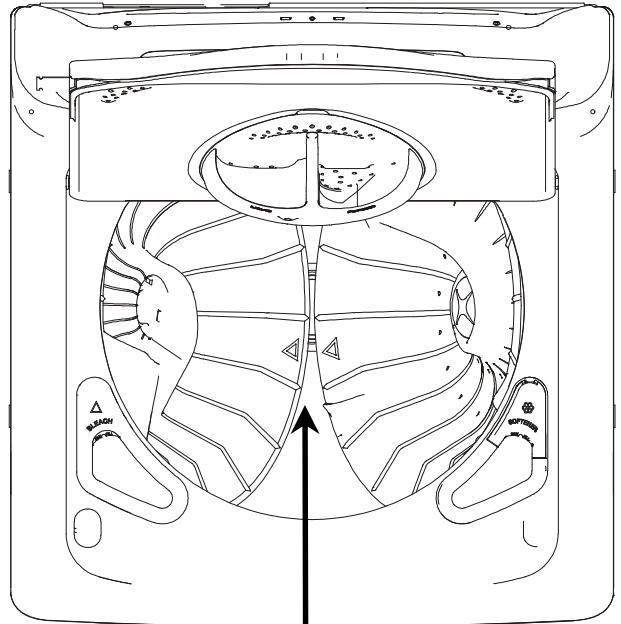

Tumbler Bearing Removal

1. Disconnect power supply to unit.
2. Lift lid.
3. Remove Tumbler.
4. Remove Torx™ screws 3 each side.

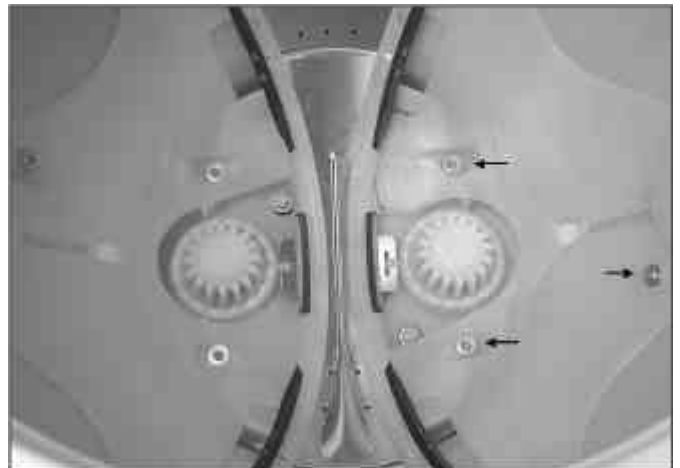

Disassembly Procedures



WARNING

To avoid risk of electrical shock, personal injury or death; disconnect power to unit before servicing.

5. Lift out Tumbler Bearing.

Transmission/O-Ring Seal Removal

1. Disconnect power supply to unit.
2. Lift lid.
3. Remove left and right Tumbler.
4. Remove left and right Tumbler Bearing.
5. Remove 4 Transmission mounting bolts.

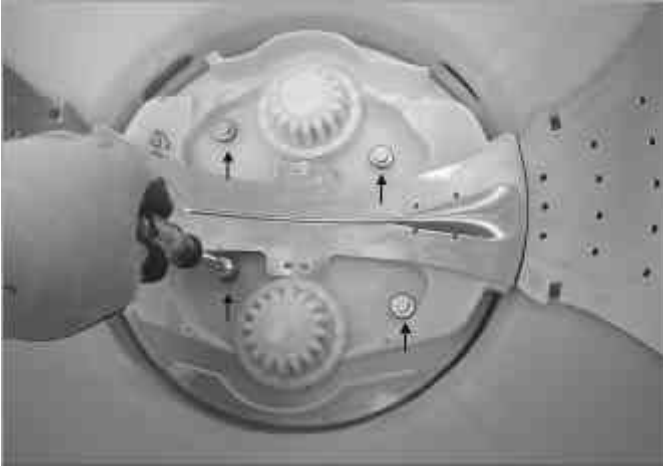

6. Lift Transmission Assembly from washer.

CAUTION: When working around stamped metal, edges may be sharp.

NOTE: Bolt pattern is designed to orient Transmission one way.

NOTE: It is recommended the O-Ring Seal be replaced if the Transmission is removed. When Replacing Transmission O-Ring Seal. Apply a small amount of detergent for lubrication before install ing new O-Ring Seal.

NOTE: A small amount of oil under the transmission is normal.

7. When installing Transmission align arrow on Spinner Support with arrow on Transmission Housing.
8. Tighten Transmission mounting bolts in a cross pattern. Seat the bolt to the Transmission Housing and then snug bolt down.

Rear Strut Removal

1. Disconnect power supply to unit.
2. Lift Top Cover.
3. Remove the Strut Assembly mounting screws.

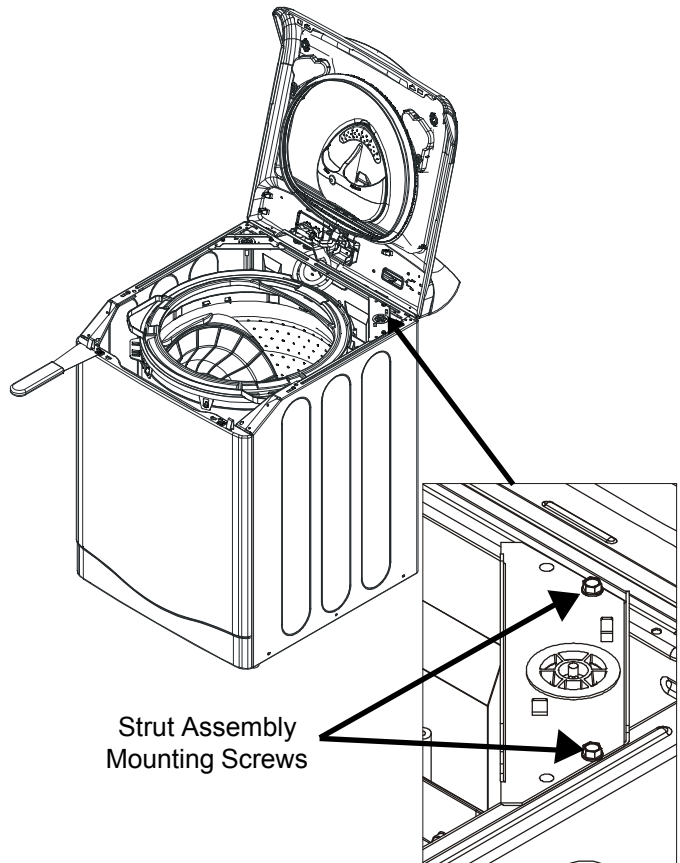

Strut Assembly
Mounting Screws

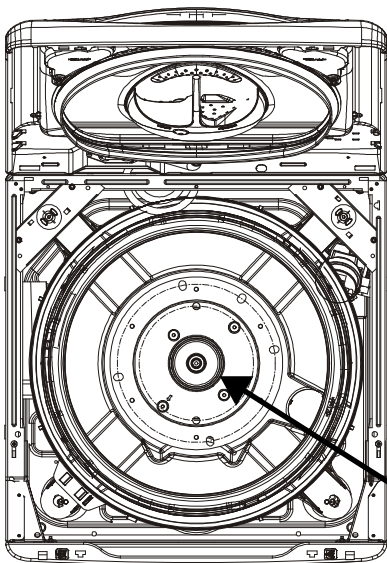

Transmission O-Ring Seal

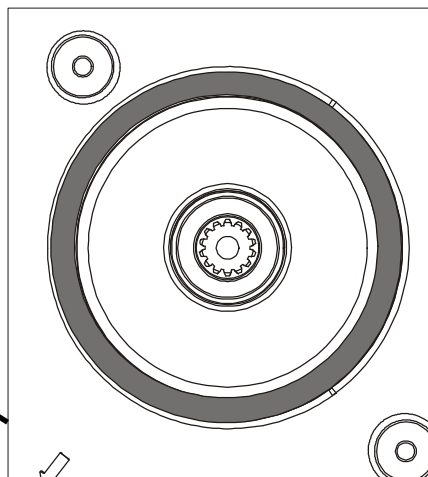

Disassembly Procedures

WARNING

To avoid risk of electrical shock, personal injury or death; disconnect power to unit before servicing.

NOTE: Remove and replace one Strut Assembly at a time. Allow Tub to hang with one Rear Strut Assembly while making repairs.

4. Lift suspended tub assembly and swing Strut through opening into tub mounting slot.

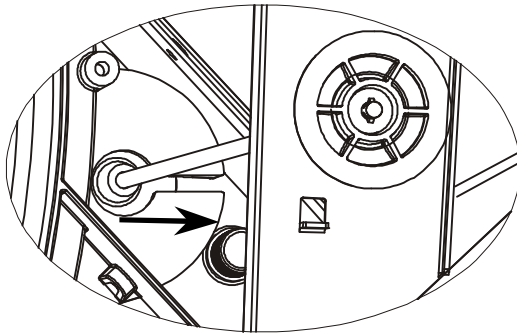

NOTE: When replacing strut grease according to instructions provided with kit.

Front Panel Removal

1. Disconnect power supply to unit.
2. Lift Top Cover.
3. Remove 2 screws on the back side of the Front Panel.

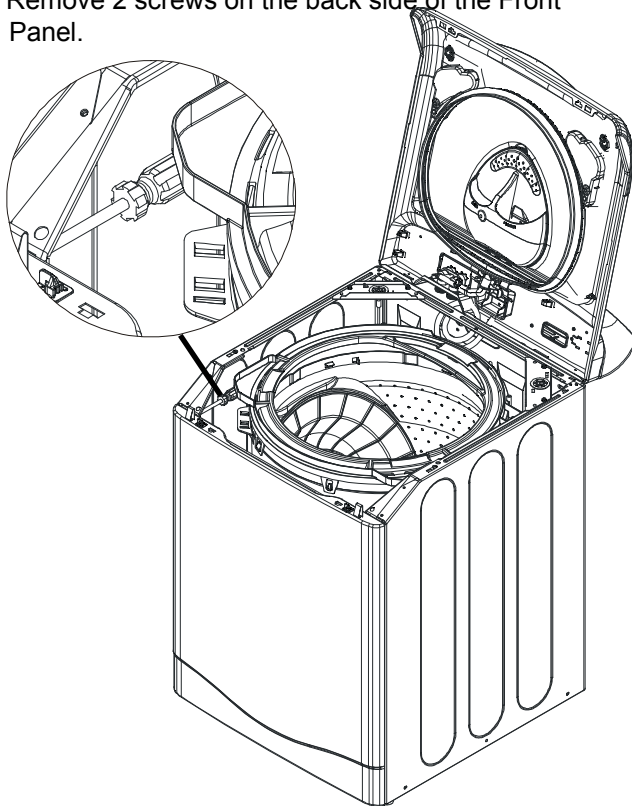

4. Tip the Front Panel forward and lift upward, clearing the J clips through the bottom of the panel.

Tub Displacement Sensor Removal

1. Disconnect power supply to unit.
2. Lift Top Cover.
3. Remove Front Panel.

Caution: Do not perform continuity check directly on Displacement Sensor due to the potential for damaging the microprocessor chip in the sensor.

Note: For diagnostics, refer to the Trouble Shooting guide located inside the Console of washer.

Note: Observe wire routing before removing Tub Sensor. Wires must be routed through the wire clips and strain relief's during reassembly.

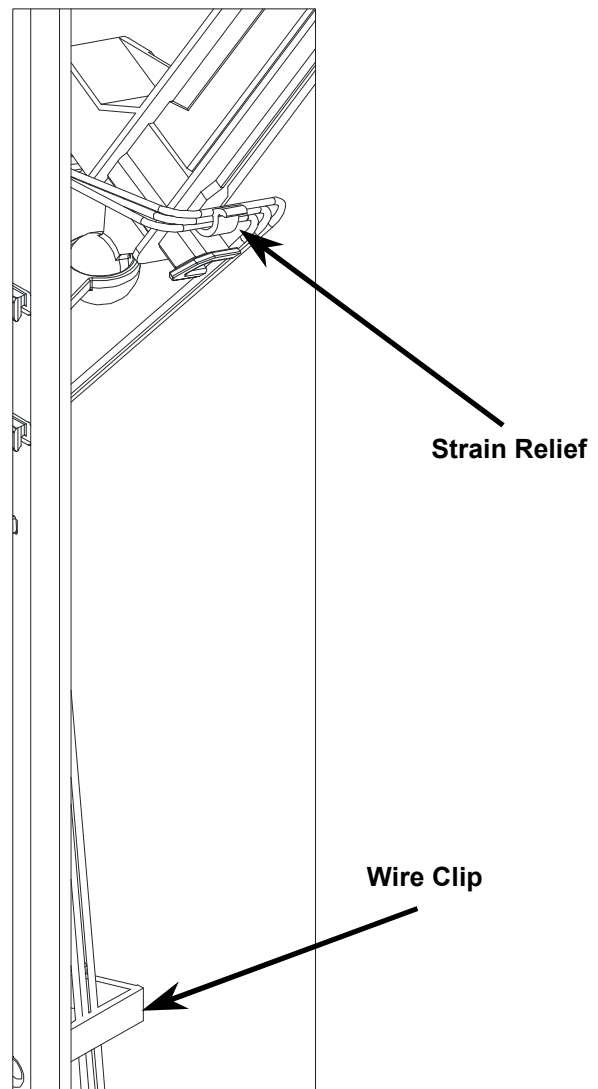

Disassembly Procedures

⚠ WARNING

To avoid risk of electrical shock, personal injury or death; disconnect power to unit before servicing.

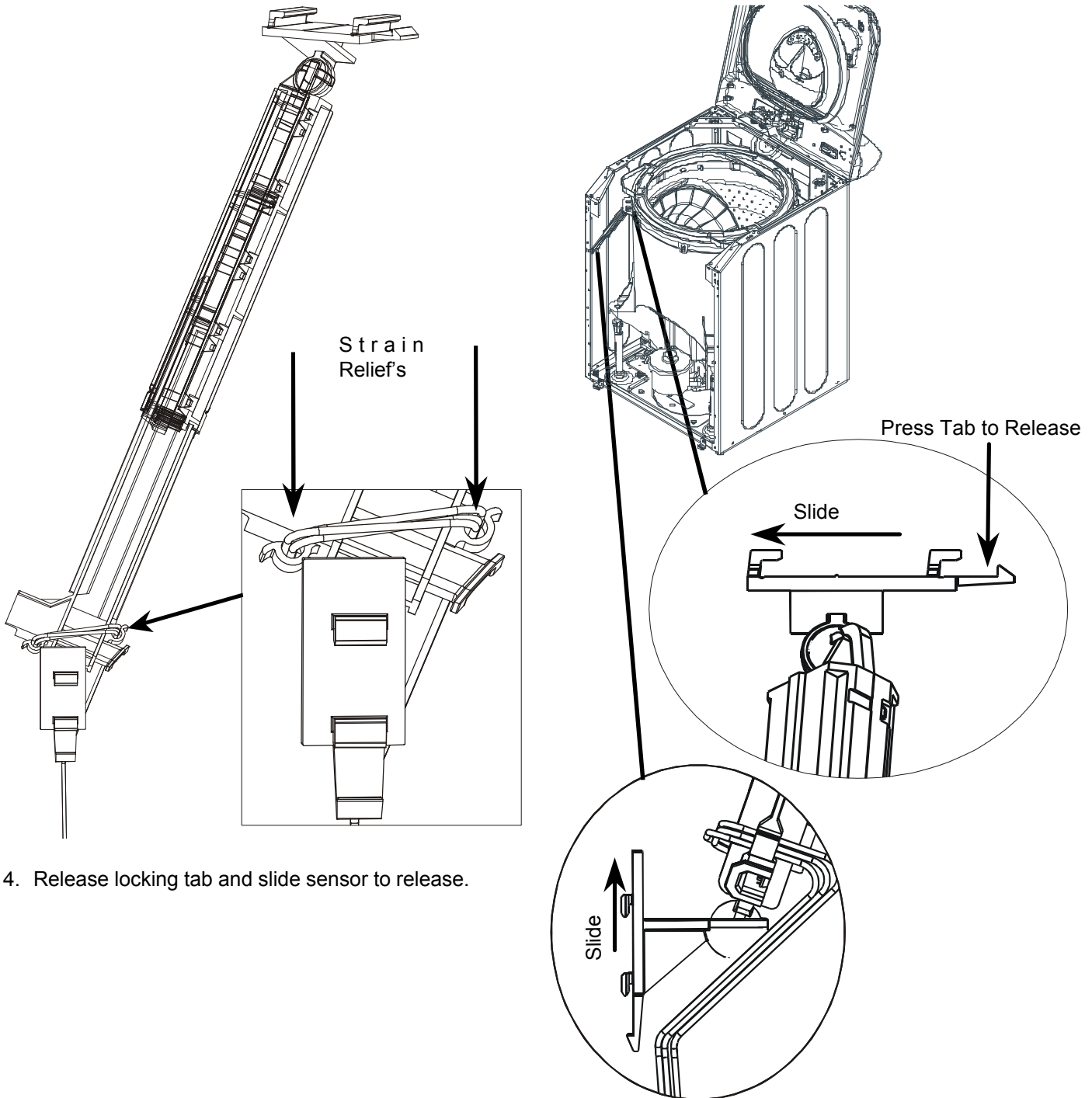

4. Release locking tab and slide sensor to release.

NOTE: When installing a new Tub Displacement Sensor, apply a small amount of grease provided with the new Tub Displacement Sensor to the terminal area. Slide the wire harness connector onto the sensor. Reroute wires through wire clips and strain relief's.

Disassembly Procedures



WARNING

To avoid risk of electrical shock, personal injury or death; disconnect power to unit before servicing.

Front Strut Removal

1. Disconnect power supply to unit.
2. Lift Top Cover.
3. Remove Front Panel.
4. Remove Tub Displacement Sensor.
5. Raise washer off floor.

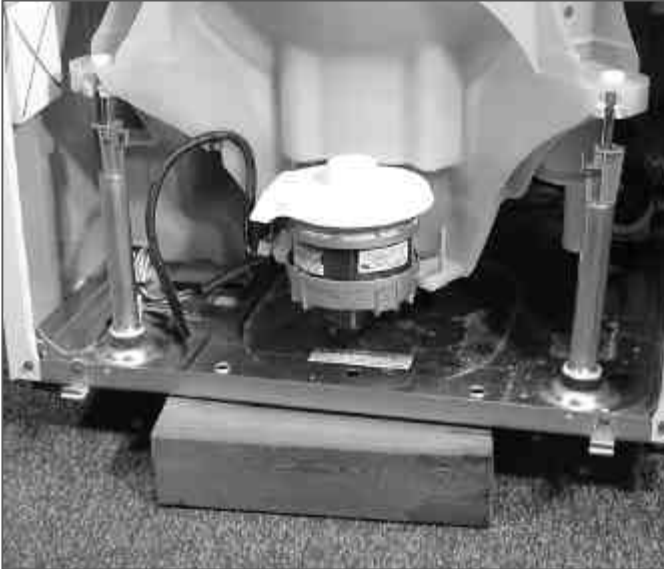

6. Use a 4"x4" wood block or equivalent to support tub.



7. Remove strut ball from tub socket.



8. Remove 3/8" lock nut on bottom of strut while holding white collar nut.



Disassembly Procedures



WARNING

To avoid risk of electrical shock, personal injury or death; disconnect power to unit before servicing.

9. Remove nut, washer, and isolator from below and lift out strut.

NOTE: When replacing the strut, replace them one at a time, making sure the nut below the base is tightened for the proper compression of the strut isolator. This should be done prior to placing the strut rod into the socket on the tub.



8. Lift Drain Pump away from washer base and remove.



Drain Pump/ Pressure Switch Removal

1. Disconnect power supply to unit.
2. Lift Top Cover.
3. Remove Front Panel.
4. Disconnect hose at tub drain.
5. Disconnect outlet hose at pump.
6. Disconnect wiring harness plugs.
7. Turn Drain Pump counterclockwise approximately 45°.

Disassembly Procedures



WARNING

To avoid risk of electrical shock, personal injury or death; disconnect power to unit before servicing.

Spinner Removal

1. Disconnect power supply to unit.
2. Lift Top Cover.
3. Remove Outer Tub Cover.
4. Remove left and right Tumblers.
6. Remove left and right Tumbler Bearings.
7. Remove 4 Transmission mounting bolts.
8. Lift Transmission Assembly from washer.
9. Remove 6 Spinner mounting bolts. Lock Spinner position with a short extension placed into empty hole in Spinner Support. Rotate Spinner until extension locks the tub in place.



Lock Spinner Position with Short Extension.

10. Lift Spinner from washer.

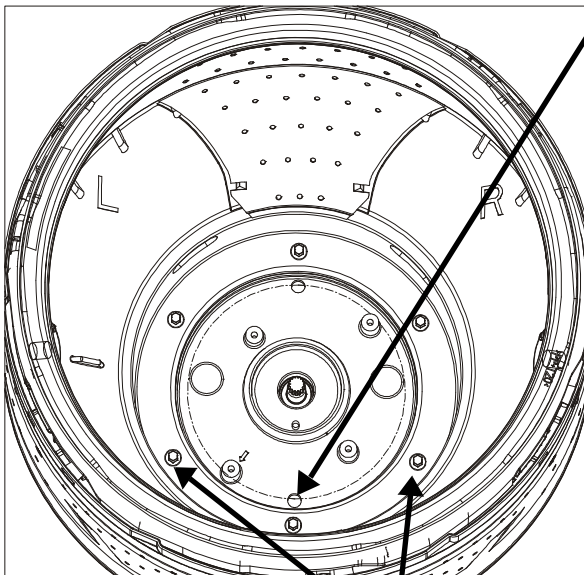

Six Spinner Bolts
Torque to 15-20 ft. lbs.

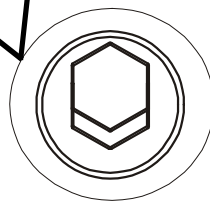

CAUTION: When working around stamped metal, edges may be sharp.

Outer Tub Removal

1. Disconnect power supply to unit.
2. Lift Top Cover.
3. Remove Front Panel.
4. Remove cabinet Corner Supports.

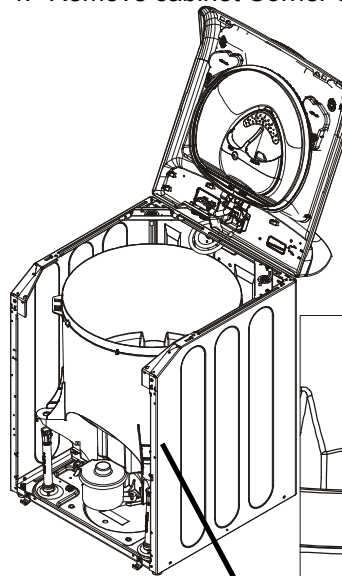

15 Torx™ screws

5. Remove Outer Tub Cover.
6. Remove left and right Tumblers.

Disassembly Procedures

WARNING

To avoid risk of electrical shock, personal injury or death; disconnect power to unit before servicing.

7. Remove left and right Tumbler Bearings.
8. Remove 4 Transmission mounting bolts.
9. Lift Transmission Assembly from washer.
10. Lock Spinner position with Short extension.
11. Remove 6 Spinner mounting bolts.
12. Lift Spinner From Washer.
13. Remove Drain Pump Hose From Outer Tub.
14. Unplug Motor Harness from Motor.
15. Remove Motor Harness Strain Relief attached to Outer Tub.

18. Unhook Rear Struts From Outer Tub. Press the Rear Strut Rod near the connection point to the tub.
19. Roll Outer Tub over pivoting on the Front Struts for support.

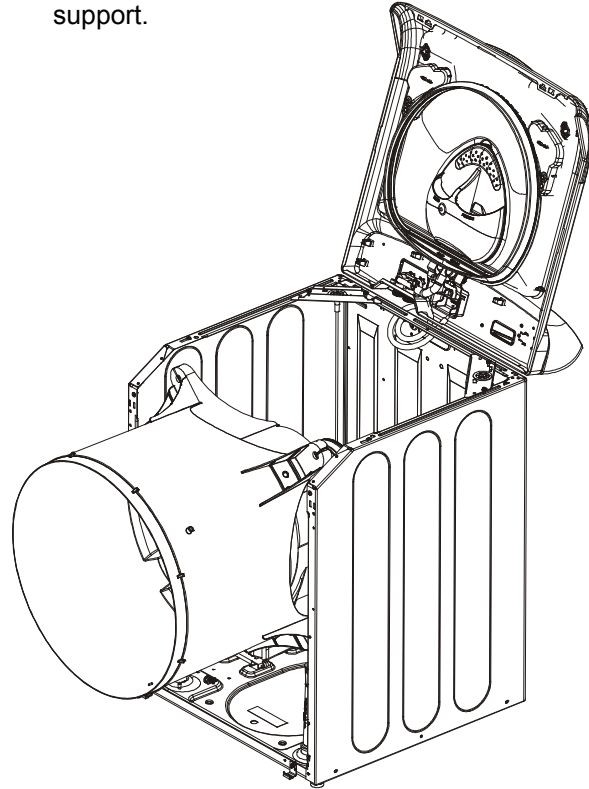
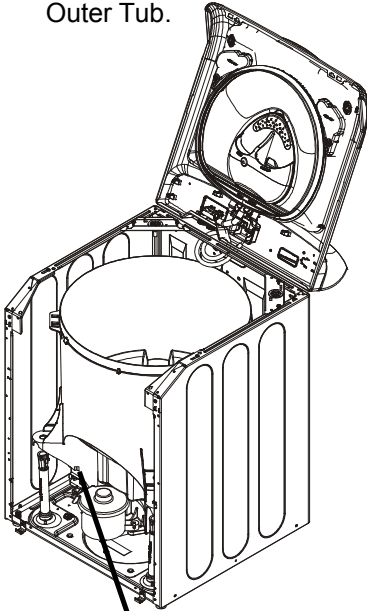

Strain Relief And Screw

20. Lift Outer Tub from washer and set on side or top.

Drive Motor Removal

1. Disconnect power supply to unit.
2. Lift Top Cover.
3. Remove Front Panel.
4. Unplug Motor Harness from Motor.
5. Loosen Drive Motor tension bolt.

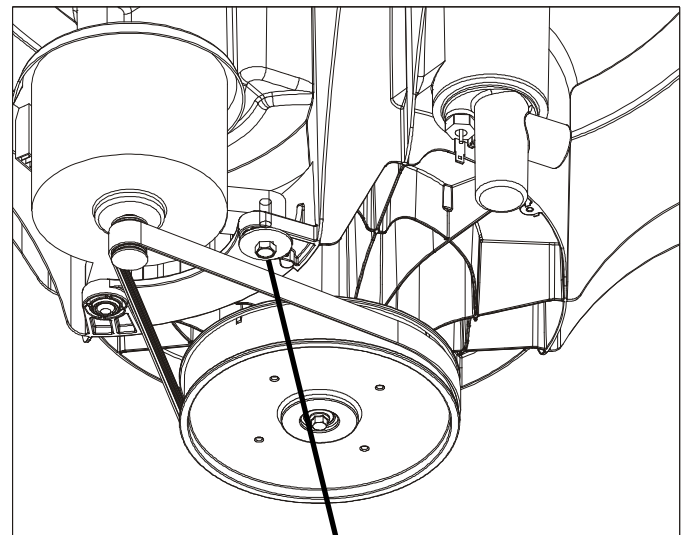
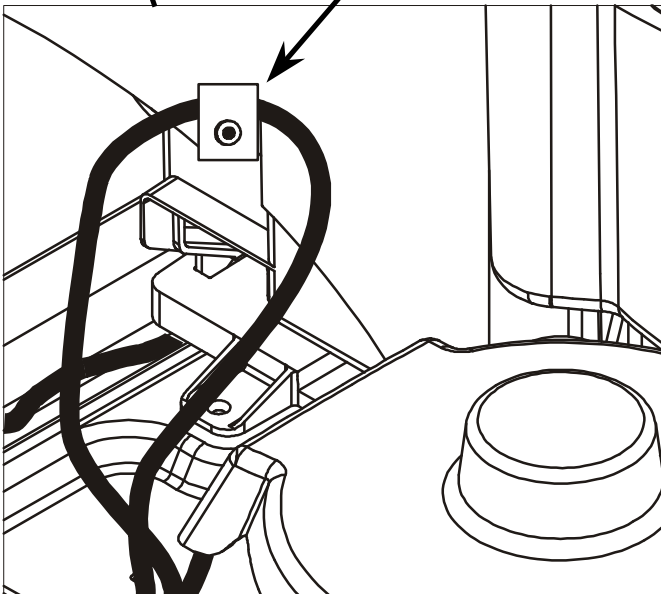

16. Unplug Heater Harness from Heater Assembly. Remove Heater Harness Strain Relief from Outer Tub (Heater Models Only).
17. Unhook Tub Displacement Sensor and tuck out of way.

Loosen Bolt

Disassembly Procedures

 **WARNING**

To avoid risk of electrical shock, personal injury or death; disconnect power to unit before servicing.

6. Remove Drive Belt.
7. Remove tension bolt.
8. Lift Motor to clear pivot shaft from tub mount.
9. Remove Motor.

Drive Belt Removal

1. Disconnect power supply to unit.
2. Lift Top Cover.
3. Remove Front Panel.
4. Roll Drive Belt off Pulley. (Do not loosen motor bolts).

Pulley/Clutch Removal

1. Disconnect power supply to unit.
2. Lift Top Cover.
3. Remove Front Panel.
4. Loosen Drive Motor Tension Bolt.
5. Remove Drive Belt.

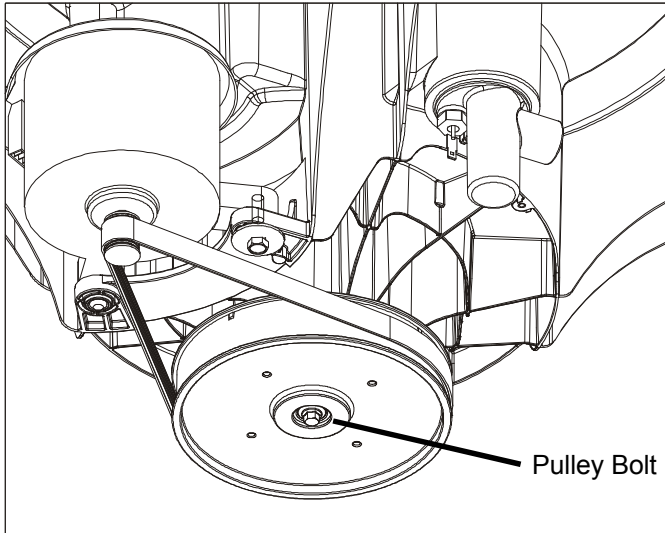

6. Remove Pulley Bolt.
7. Remove Pulley.

NOTE: When reinstalling, properly seat Pulley with a 1/16-1/8" gap between the Pulley face and shaft end. On reinstallation, tighten Pulley Bolt to 96 inch pounds.



Heater Assembly Removal (Heater Not included on all models. Non heater models see note.)

1. Disconnect power supply to unit.
2. Lift Top Cover.
3. Remove Front Panel.
4. Remove Heater Harness plugs.
5. Remove Spark Gap plug.
6. Release locking tab and twist Heater Assembly or Cap to remove.

NOTE: Models without a factory installed heater are supplied with a removable cap in the heater location. Follow steps 1 thru 3 and 6 to remove the cap.

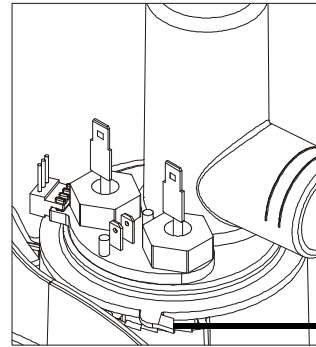

Motor Control Removal

1. Disconnect power supply to unit.
2. Lift Top Cover.
3. Remove Front Panel.
4. Remove 5/16 screw securing Motor Control to Base Pan.
5. Remove wire harness from clips.



Release Wire Harness from Clips

Disassembly Procedures



WARNING

To avoid risk of electrical shock, personal injury or death; disconnect power to unit before servicing.

6. Slide Motor Control between Motor and Strut.



8. Unplug connectors from board.



Spinner Support Removal

1. Disconnect power supply to unit.
2. Lift Top Cover.
3. Remove Front Panel.
4. Remove cabinet Corner Supports.
5. Remove Outer Tub Cover.
6. Remove left and right Tumblers.
7. Remove left and right Tumbler Bearings.
8. Remove 4 Transmission mounting bolts.
9. Lift Transmission Assembly from washer.
10. Lock Spinner position with Short extension.
11. Remove 6 Spinner mounting bolts.
12. Lift Spinner From Washer.
13. Remove Drain Pump Hose From Outer Tub.
14. Unplug Motor Harness from Motor.
15. Remove Motor Harness Strain Relief attached to Outer Tub.
16. Unplug Heater Harness from Heater Assembly. Remove Heater Harness Strain Relief from Outer Tub (Heater Models Only).
17. Unhook Tub Displacement Sensor and tuck out of way.
18. Unhook Rear Struts From Outer Tub. Press the Rear Strut Rod near the connection point to the tub.
19. Roll Outer Tub over pivoting on the Front Struts for support.
20. Lift Outer Tub from washer and set on side or top.
21. Loosen Drive Motor tension bolt.
22. Remove Drive Belt.
23. Remove Pulley Bolt and Pulley.
24. Remove the Spinner Nut. Special wrench is available from Maytag to aid in removal. Place the Spinner Support Removal Tool over nut and locked in place.



Disassembly Procedures

 **WARNING**

To avoid risk of electrical shock, personal injury or death; disconnect power to unit before servicing.

25. Insert wrench handle in shaft with graphic facing up. Make sure the handle is fully seated on the shaft and turn clockwise.

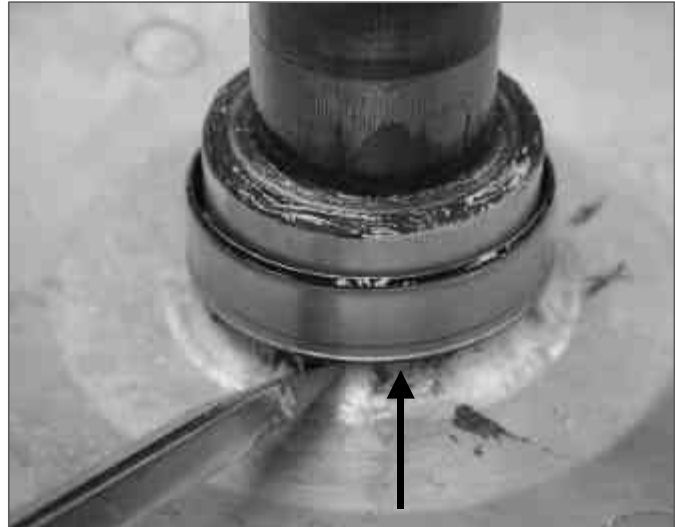

27. Insert the sleeve into the seal and press.

26. Lift out Spinner Support.

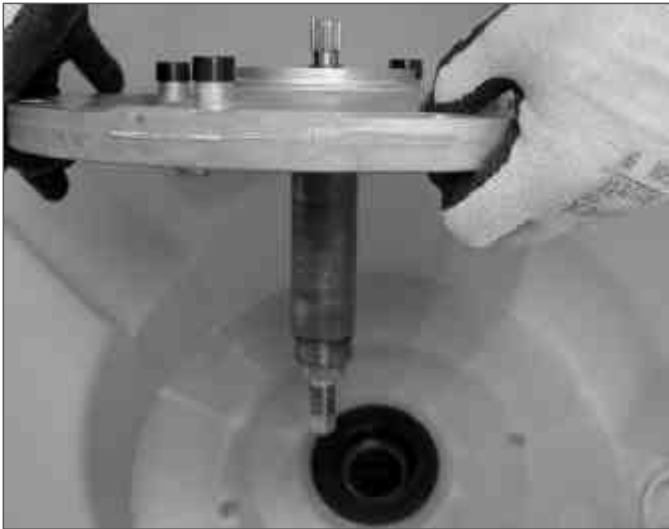

NOTE: The sleeve from the seal can come out on the Spinner Support Shaft. If Spinner Support is reinstalled, remove the seal sleeve. A new seal and sleeve should be inserted into the Outer Tub.



NOTE: When installing a new seal, make sure the sleeve from the previous seal has been removed and discarded.

Appendix A

MAYTAG



AUTOMATIC WASHER INSTALLATION INSTRUCTIONS

MISE EN SERVICE MACHINE À LAVER

LAVADORA AUTOMÁTICA INSTRUCCIONES DE INSTALACION



LEAVE THESE INSTRUCTIONS WITH THE OWNER

***LAISSER CES EXPLICATIONS DE MISE EN
SERVICE AU PROPRIÉTAIRE***

***CERCIÓRESE DE DEJAR ESTAS INSTRUCCIONES
CON EL PROPIETARIO.***

Read this before you start...

PARTS supplied for installation:

Cable tie to secure drain hose to standpipe, inlet hose or laundry tub



2 washers and 2 screens for water hoses



TOOLS needed for installation:

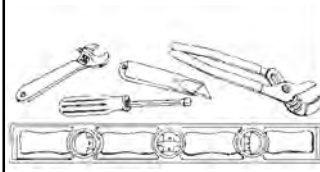

- Cutting knife
- Channel lock
- Nut driver
- Level
- Crescent wrench

Proper installation is the responsibility of the purchaser.

SERVICE CALLS PERFORMED AS A RESULT OF POOR INSTALLATION ARE THE RESPONSIBILITY OF THE INSTALLER.

Overall Cabinet Dimensions

Width = 27 1/4" (69.2 cm)

Depth = 29 1/4" (74.3 cm) allow room for hoses.

Height to top of console = 44 3/4" (113.7 cm)

Height to top of open lid = 55 3/4" (141.6 cm)

Prepare Washer

Step 1

- Remove the carton by cutting only marked areas of the carton. **CAUTION: Hoses are connected to the washer.**

NOTE: If the washer is moved without the carton in place, be sure to keep sharp edges from damaging the washer cabinet or attached hoses.

- Lift the carton up and clear of the washer. Carefully remove any packaging materials from the outside of the washer. **NOTE: Retain the corner posts for later use.**
- Untape and raise the washer lid, remove the items shipped in the spin basket. Save the literature for future reference. Close and tape lid.

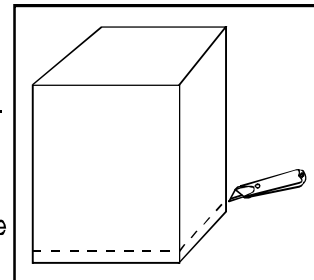

Step 2

With the lid taped shut, lay corner posts on the floor, as shown. Use one corner post to support the top, and three posts for the bottom. Gently tip the washer on its back, laying it across the corner posts.

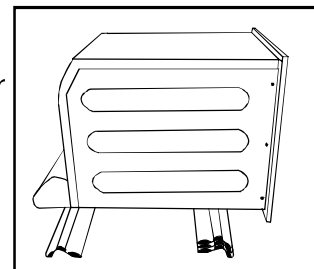

Step 3

Remove the hex head screw at the rear of the shipping base. Pull plastic base away from rear feet, and pull downward to disengage from front feet. Recycle or discard the plastic base. Return washer to upright position. Untape the washer lid.

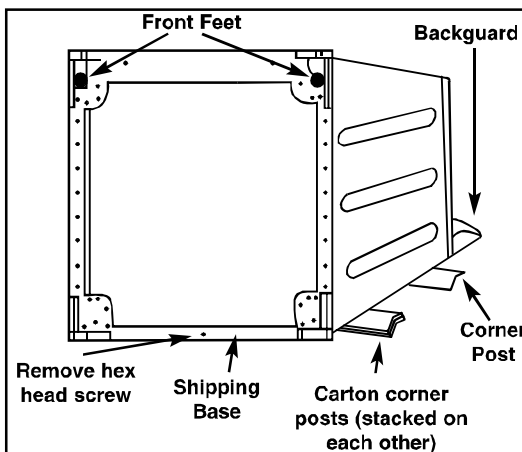

INSTALL THE WASHER

1. Place the drain hose in the drain facility. To change drain hose direction or prevent hose from collapsing or becoming damaged, turn the end of the hose while holding the base of the hose stationary.

Be sure an air-tight connection is **NOT** made between the drain hose and the standpipe. A Standpipe height of 36" is recommended. Standpipe must also be a minimum of 1-1/8 in. inside diameter.

NOTE: If drain standpipe is in excess of 5 feet above floor level, a drain hose extension kit (Part #12001660) will need to be installed.

NOTE: Caution must always be exercised to avoid collapsing or damaging the drain hose. For best performance the drain hose should not be restricted in any way, through elbows, coupling's or excessive lengths.

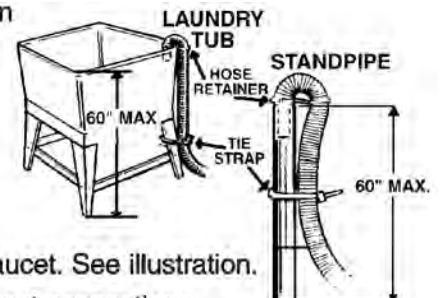
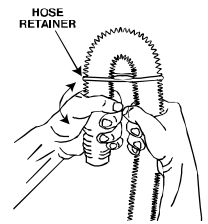

2. Install one screen strainer and washer on the inside of each fill hose at the faucet. The dome on the screen strainer must point towards the faucet. See illustration.
3. Thread the inlet hoses with the screen washer to the HOT and COLD faucet connections. Make sure the hose marked "HOT" is attached to the HOT faucet. Tighten by hand until snug and then 2/3 of a turn with pliers. Verify hose connections to machine are tight. **DO NOT OVER TIGHTEN.**

Turn on "HOT" and "COLD" water supply and check all connections at the water valve on the machine and at the faucet for leaks.

NOTE: Machine is supplied with 4 feet inlet hoses. Accessory inlet hoses are available in various lengths up to 10 feet. See accessory parts section.

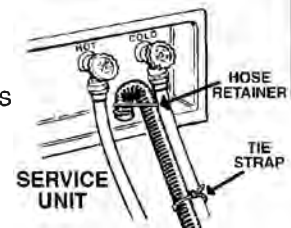
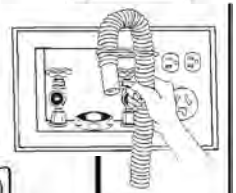

4. Plug power cord into a grounded 120 volt 60 Hz approved electrical service protected by a 15 amp fuse or comparable circuit breaker. This washer is grounded through the third prong of the power cord when plugged into a three prong grounded receptacle.

NOTE: NEVER USE AN EXTENSION CORD. NEVER MODIFY WITH AN ADAPTER THAT MAY ELIMINATE THE GROUND CONNECTION ON THE PLUG. IF A THREE PRONG GROUND RECEPTACLE IS NOT AVAILABLE, SEE ADDITIONAL GROUNDING CONNECTIONS SECTION.

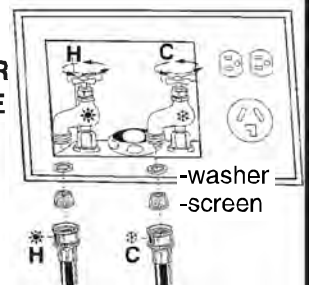
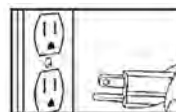

5. Slide washer into position.

NOTE: The washer must be leveled on all 4 legs. To properly level a machine, the top cover and the front panel must be securely fastened. A carpenter's level should be used on top cover to level the machine front to back, as shown in illustration. To level the machine side to side, place level on back edge of the lid as shown in the illustration. It's a good idea to check for level again after the first dozen washes and re-level if necessary.

6. Level washer by turning the leveling legs in or out as necessary. When the washer is level, **tighten the leveling leg lock nuts up against the base of the washer. This will help prevent the machine from an out of level condition after use.** It is preferable to level the machine with the legs only minimally extended.

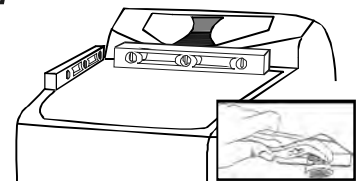

FINAL INSTALLATION CHECKLIST

- Instructions and Installation Kit have been removed from tub.
- Washer is plugged into electrical outlet and is properly grounded.
- Water hoses are connected to the faucet's with inlet screens and washers.
- Water is turned on and checked for leaks at faucet and water valve connections.
- Drain hose is properly located into drain facility and is not collapsed or damaged.
- Washer has been properly leveled. All legs should be firmly on the floor and leveling leg lock nuts MUST be tightened.
- Test for proper operation by running the washer through the following complete cycle.

FAV6800

1. Press "Normal" to turn the washer on.
2. Arrow up to select "Hot/Cold" wash-rinse temperature.
3. Press "Start/Pause" to begin the cycle.
4. Allow the Lid to lock and verify that the Lid has locked.
5. Allow the washer to fill with hot water.
6. Press "Start/Pause" to pause the cycle.
7. Allow the Lid to unlock, lift the Lid and verify the washer has filled with hot water.
8. Lower the Lid and Press "Off".
9. Press "Normal", Press "Bulky Items"
10. Arrow up to select "Cold/Cold" wash-rinse temperature.
11. Press "Start/Pause" to begin the cycle.
12. Allow the washer to fill with cold water.
13. Press "Start/Pause" to pause the cycle.
14. Allow the Lid to unlock, lift the Lid and verify the washer has filled with cold water.
15. Lower the Lid and press "Off".
16. Press "Normal", Press "Spin Only".
17. Press "Start/Pause" to begin the cycle.
18. Verify the washer spins. This will take several minutes, the machine will first drain on slow spin speed.
19. Allow the Spin cycle to finish, verify that the Lid has unlocked at the end of the cycle.
20. Press "Off".

FAV9800

1. Press "Home", select "Set Your Own Cycle", select "Cottons", select "Hot Wash Cold Rinse".
2. Press "Start/Pause" to begin the cycle.
3. Allow the Lid to lock and verify that the Lid has locked.
4. Allow the washer to fill with hot water.
5. Press "Start/Pause" to pause the cycle.
6. Allow the Lid to unlock, lift the Lid and verify that the washer has filled with hot water.
7. Lower the Lid and Press "Off".
8. Press "Home", select "Set Your Own Cycle", select "Rinse or Spin Only Cycles", select "Cold Rinse & Spin"; press "Start/Pause" to begin the cycle.
9. Allow the washer to fill with cold water.
10. Press "Start/Pause" to pause the cycle.
11. Allow the Lid to unlock, lift the Lid to verify that the washer has filled with cold water.
12. Lower the Lid and Press "Off".
13. Press "Home", select "Set Your Own Cycle", select "Rinse or Spin Only Cycles", select "Spin".
14. Press "Start/Pause" to begin the cycle.
15. Verify the washer spins. This will take several minutes, the machine will first drain on slow spin speed.
16. Allow the Spin cycle to finish, verify that the Lid has unlocked at the end of the cycle.
17. Select "Ok".
18. Press "Off"

Make any corrections necessary to properly complete the installation.

COLD WEATHER STORAGE

The following precautions should be taken if a washer is to be stored, after use or where it would be subject to freezing conditions.

1. Turn off the water supply, then remove the inlet hoses.
2. Select a fill cycle and energize the water valve by selecting a warm water setting. A few seconds of fill is sufficient.
3. Disconnect from electrical supply.
4. Remove the drain hose cover from upper left corner of cabinet back.
5. Lower the drain hose to floor level and tilt washer backwards to remove water from the drain hose and pump.
6. Re-install the drain hose cover.
7. When machine is reinstalled allow machine to stabilize to room temperature. See location considerations.

FLOORING

For best performance the washer must be installed on a solidly constructed floor. Wood floors may need to be reinforced to minimize vibration and/or unbalanced load situations. Carpeting and soft tile surfaces are contributing factors in vibration and/or tendency for a washer to move slightly during the spin cycle. Never install the washer on a platform or weakly supported structure.

LOCATION CONSIDERATIONS

It is recommended the washer never be installed in areas where water may freeze since the washer will always maintain some water in the water valve, pump and hose areas. This can cause damage to belts, pump, hoses and other components. Operating temperature should be above 60°F.

ALCOVE OR CLOSET INSTALLATION

MINIMUM CLEARANCES FOR CLOSET AND ALCOVE INSTALLATIONS:

Sides – 0 in.	Rear – 1 in.
Top – 2 in.	Closet Front – 0 in.

The closet front must have a total unobstructed air opening of 72 sq. in. minimum. A louvered door with equivalent air opening is acceptable.

IMPORTANT TO INSTALLER

PLEASE READ THE PRECEDING INSTRUCTIONS CAREFULLY BEFORE STARTING TO INSTALL THE WASHING MACHINE. THESE INSTRUCTIONS SHOULD BE RETAINED FOR FUTURE REFERENCE.

REMOVE THE DOOR FROM ALL DISCARDED APPLIANCES TO AVOID THE DANGER OF A CHILD SUFFOCATING.

ADDITIONAL INFORMATION

50 HERTZ OPERATION

This Maytag appliance is manufactured for operation on 60 Hz AC approved electrical service. This model is not designed for use on 50 Hz AC electrical service and conversion of the product from 60 to 50 Hz operation is not recommended. For additional information on 50 Hz products, write:

MAYTAG INTERNATIONAL, INC.
8700 BRYN MAWR AVE.
CHICAGO, ILLINOIS 60631
Phone: 773-714-0100

FOR TECHNICAL ASSISTANCE, REPLACEMENT PARTS AND ACCESSORIES

For technical assistance or if your washer requires replacement parts or accessories, contact **Maytag Customer Service, toll-free 1-888-4-Maytag** for information on the nearest authorized Maytag Parts Distributor.

REQUIREMENTS

ELECTRICAL

120 Volt 60 Hz 15 AMP Fuse or Circuit Breaker

Individual branch circuit serving only the washer is recommended.

NEVER USE AN EXTENSION CORD.

GROUNDING

ELECTRICAL GROUND IS REQUIRED ON THIS APPLIANCE.

Appliance is equipped with a power cord having a 3-prong grounding plug for use in a properly installed and grounded outlet.



- Improper connection of the equipment-grounding conductor can result in a risk of electrical shock. Check with a qualified electrician or serviceman if you are in doubt as to whether the appliance is properly grounded. Do not modify the plug provided with the appliance – if it will not fit the outlet, have a proper outlet installed by a qualified electrician.

IMPORTANT SAFETY PRECAUTIONS

- To prevent unnecessary risk of fire, electrical shock or personal injury, all wiring and grounding must be done in accordance with the National Electrical Code ANSI/FNPA, No. 70-Latest Revision and local codes and ordinances. It is the personal responsibility and obligation of the appliance owner to provide adequate electrical service for this appliance.

ADDITIONAL GROUNDING CONNECTIONS

A grounding kit (Part No. 12001875) is available. It contains the ground wire, clamp, ground screw and washer. Connect the ground wire to back of unit with the cabinet ground screw and washer. Secure the other end of ground wire to a grounded **COLD** metal water pipe.

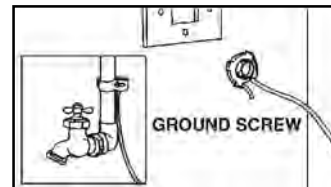

NEVER CONNECT GROUND WIRE TO PLASTIC PLUMBING LINES, GAS LINES OR HOT WATER PIPES.

WATER

Water pressure of 20 to 120 p.s.i. is required to correctly fill the washer in the proper time. Pressures of less than 20 p.s.i. may cause a failure in the water valve, detergent dispenser, fabric softener dispenser or bleach dispenser. Low pressure may also cause the fill times to be extended past the time the washer is allowed to fill. The water valve may not shut off completely when the pressure is insufficient.

Hot and Cold water faucet's must be within 4 feet of the back of the washer for inlet hoses provided with the washer. NOTE: Accessory inlet hoses are available in various lengths up to 10 feet for faucet's more than 4 feet from the back of the washer. See accessory parts section.

TO AVOID THE POSSIBILITY OF WATER DAMAGE, SHOULD A HOSE LEAK, ALWAYS HAVE FAUCET'S ACCESSIBLE AND TURN OFF FAUCET'S WHEN WASHER IS NOT IN USE.

Water heater should be set to deliver a minimum of 120° – 140° F (49° – 60° C) water to the washer.

ACCESSORY PARTS:

Description	Part Number	Description	Part Number
4 Ft. Fill Hose	33-7891	4 Ft. Stainless Steel Braided Hose	22002733
5 Ft. Fill Hose	33-7046	5 Ft. Stainless Steel Braided Hose	22002734
5 Ft. Fill Hose with 90 degree Elbow	200672	Hose Washer Kit	12001413
6 Ft. Fill Hose	21001466	Drain Hose Extension Kit	12001660
6 Ft. Fill Hose with 90 degree Elbow	200688	Pump Accessory Kit	12001674
10 Ft. Fill Hose	21001467	Grounding Kit	12001875

Appendix B



MAYTAG NEPTUNE® TL WASHER

USE & CARE

G U I D E

TABLE OF CONTENTS

Safety Instructions	1-2
Operating Instructions	3-6
Water Use	6
Detergent Use	7
Features	7-8
Care and Cleaning	9
Storing the Washer	10
Troubleshooting	10-12
Operating Sounds	13
Questions and Answers	14
Warranty	15
Guide d'utilisation et d'entretien	16
Guía de uso y cuidado	32

WELCOME

Welcome and congratulations on your purchase of a Maytag Neptune® TL washer! Your complete satisfaction is very important to us. For best results, we suggest reading this material to help acquaint you with proper operating and maintenance procedures.

Should you need assistance in the future, it is helpful to:

- 1) Have complete model and serial number identification of your washer. This is located on a data plate on the back right side of the control panel.

Date of Purchase _____

Model Number _____

Serial Number _____

- 2) **IMPORTANT: Keep this guide and the sales receipt in a safe place for future reference. Proof of original purchase date is needed for warranty service.**

If you have questions, call:

Maytag Customer Assistance
1-888-462-9824 USA and CANADA
(Mon.–Fri., 8am–8pm Eastern Time)
Internet: <http://www.maytag.com>

U.S.A. customers using TTY for deaf, hearing impaired or speech impaired, call 1-800-688-2080.

NOTE: In our continuing effort to improve the quality of our appliances, it may be necessary to make changes to the appliance without revising this guide.

For service and warranty information, see page 15.

IMPORTANT SAFETY INSTRUCTIONS

read before operating your washer

WHAT YOU NEED TO KNOW ABOUT SAFETY INSTRUCTIONS

Warning and Important Safety Instructions appearing in this manual are not meant to cover all possible conditions and situations that may occur. Common sense, caution, and care must be exercised when installing, maintaining or operating appliance.

Always contact your dealer, distributor, service agent, or manufacturer about problems or conditions you do not understand.

RECOGNIZE SAFETY SYMBOLS, WORDS, LABELS

WARNING

WARNING – Hazards or unsafe practices which **COULD** result in severe personal injury or death.

CAUTION

CAUTION – Hazards or unsafe practices which **COULD** result in minor personal injury or property damage.

SAVE THESE INSTRUCTIONS

IMPORTANT SAFETY INSTRUCTIONS

WARNING

To reduce the risk of fire, electric shock or injury to persons when using the appliance, follow basic precautions, including the following:

1. Read all instructions before using the appliance.
2. As with any equipment using electricity and having moving parts, there are potential hazards. To use this appliance safely, the operator should become familiar with the instructions for operation of the appliance and always exercise care when using it.
3. Do not install or store this appliance where it will be exposed to the weather.
4. Install and level washer on a floor that can support the weight.
5. This appliance must be properly grounded. Never plug the appliance cord into a receptacle which is not grounded adequately and in accordance with local and national codes. See installation instructions for grounding this appliance.
6. To avoid the possibility of fire or explosion:
 - a. Do not wash items that have been previously cleaned in, washed in, soaked in, or spotted with gasoline, dry-cleaning solvents, other flammable or explosive substances as they give off vapors that could ignite or explode. Hand wash and line dry any items containing these substances.

Any material on which you have used a cleaning solvent, or which is saturated with flammable liquids or solids, should not be placed in the washer until all traces of these liquids or solids and their fumes have been removed.

These items include acetone, denatured alcohol, gasoline, kerosene, some liquid household cleaners, some spot removers, turpentine, waxes and wax removers.
 - b. Do not add gasoline, dry-cleaning solvents, or other flammable or explosive substances to the wash water. These substances give off vapors that could ignite or explode.
 - c. Under certain conditions, hydrogen gas may be produced in a hot water system that has not been used for two weeks or more. **HYDROGEN GAS IS EXPLOSIVE.** If the hot water system has not been used for such a period, before using a washing machine or combination washer-dryer, turn on all hot water faucets and let the water flow from each for several minutes. This will release any accumulated hydrogen gas. As the gas is flammable, do not smoke or use an open flame during this time.
 - d. Do not wash or dry items that are soiled with vegetable or cooking oil. These items may contain some oil after laundering. Due to the remaining oil, the fabric may smoke or catch fire by itself.
7. Do not reach into the appliance if the tub or tumblers are moving.
8. Do not allow children or pets to play on, in, or in front of the appliance. Close supervision is necessary when the appliance is used near children and pets.
9. Do not tamper with controls.
10. Do not repair or replace any part of the appliance or attempt any servicing unless specifically recommended in published user-repair instructions that you understand and have the skills to carry out.
11. Unplug power supply cord before attempting to service your washer. Service is to be done only by qualified service personnel.
12. Keep all laundry aids such as detergents, bleach, etc., out of the reach of children, preferably in a locked cabinet. Use laundry aids only as directed by the manufacturer. Observe all warnings on container labels.
13. Keep the area around and underneath washer free from the accumulation of combustible materials, such as lint, paper, rags, gasoline, and all other flammable vapors and liquids.
14. Do not use chlorine bleach and ammonia or acids (such as vinegar or rust remover) in the same wash. Hazardous fumes can form.
15. Do not machine wash fiberglass materials. Small particles can stick to fabrics washed in following loads and cause skin irritation.
16. For flame resistant finishes - follow garment manufacturer's instructions carefully. Improper laundering could remove the finish.
17. Before the appliance is removed from service or discarded, remove the lid to the washing compartment.
18. Inlet hoses are subject to damage and deterioration over time. Check the hoses periodically for bulges, kinks, cuts, wear or leaks and replace them every five years.

OPERATING INSTRUCTIONS

For detailed information on sorting, pretreating stains, etc., see the enclosed **Laundering Tips** booklet.

Step 1

LOAD THE CLOTHES WASHER

- Put dry, unfolded clothes loosely in the tub, up to the top row of holes for a maximum load. Do not pack down the load.
- Overloading may reduce washing efficiency, cause excess wear and possibly cause creasing or wrinkling of the load.
- Wash delicate items such as bras, hosiery and other lingerie in the “**delicates**” or “**hand wash**” cycle with similar lightweight items.
- **DO NOT** overload the washer when washing large, bulky items such as comforters, blankets or mattress pads. Items should fit loosely in the tub, below the top row of holes. Use the “**bulky items**” cycle for these loads.
- When washing smaller, bulky items that do not fill the tub completely such as a rug, one pillow, stuffed toys or one or two sweaters, a few towels should be added for improved tumbling and spin performance.
- When washing heavily soiled loads, it is very important to avoid overloading the washer to assure good cleaning results.
- To add a forgotten item, press the **Start/Pause** pad, wait for the Locked light to go out, add the item, close the lid and press the **Start/Pause** pad. After a pause of up to one minute, the cycle will resume.
- Close lid carefully to avoid slamming.

NOTE: To assure that your additional items get clean, do not wait more than five minutes after the cycle has started to add the item.

Step 2

SELECT CYCLE

Control features vary by model.

Press the appropriate cycle pad for the type of load. This will determine the tumble pattern and spin speed for the cycle.

NOTE: To minimize wrinkling of loads, select the Wrinkle Control cycle.

Normal – For most fabrics including cottons, linens and normally soiled garments.

Wrinkle Control – For “wash and wear” and synthetic fabrics and lightly to normally soiled garments.

Delicates – For sheer fabrics, bras and lingerie.

Hand Wash – For wool, silk and other hand-wash-only fabrics. For best results, use liquid detergent.

Quick Wash – For lightly soiled or wrinkled garments needed quickly.

Super Wash – For sturdy, colorfast fabrics and heavily soiled garments.

Whites – For white fabrics with or without bleach.

Colors/Jeans – For bright fabrics or fabrics that may bleed.

Bulky Items – For larger items such as comforters, blankets and mattress pads.

Enviro Plus – For geographic areas where energy and water conservation is needed.

Spin Only – For all fabrics and garments needing only a spin.



OPERATING INSTRUCTIONS

Step 3

SELECT WASH/RINSE WATER TEMPERATURES

Press the arrow pad to select the wash and rinse water temperatures. Follow the garment care label and chart below for best results.

Hot/Cold – Whites and heavily soiled color-fast items

ATC Warm/Warm – Color-fast items. When warm rinse is selected, only the final rinse will be warm. The other rinses will be cold to conserve energy.

ATC Warm/Cold – Moderately soiled, color-fast items; most wrinkle free items

ATC Cold/Cold – Brightly colored, lightly soiled items

Cold/Cold – Brightly colored, very lightly soiled items; washable woolsens

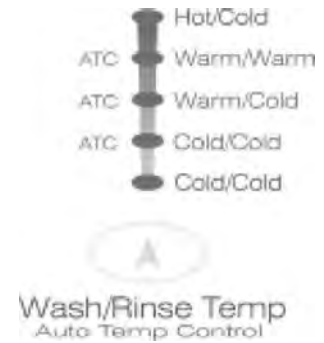

IMPORTANT: The washer features an automatic temperature control (ATC) to provide a warm wash of approximately 105° F and cold wash of approximately 85° F on the ATC temperature selections.

REMEMBER: In wash water temperatures below 65° F, detergents do not dissolve well or clean well. Care labels define cold water as up to 85° F.

Step 4

SELECT SOIL LEVEL

Press the arrow pad to select the Soil Level/washing time.

Stain Treat – Use for clothing with stains.

Heavy – Use for cleaning heavily soiled loads.

Medium – Use for cleaning moderately soiled loads. This setting will be appropriate for most loads.

Light – Use for cleaning lightly soiled loads.

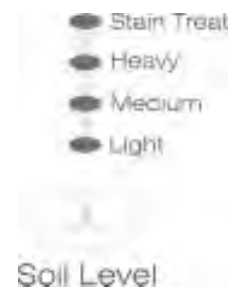

OPERATING INSTRUCTIONS

Step 5

SELECT SPIN

Press the arrow pad to select the spin speed.

Max Extract – Use for heavy loads such as towels and bedding. Removes more water from loads during spin.

FABRICS NOTE: To minimize wrinkling of wrinkle free and no-iron fabrics, do not use the Max Extract spin option for these loads. Also, DO NOT overload the washer.

High/Flat Dry – Use for underwear, t-shirts and sturdy cottons or for items that will be laid flat to dry.

Medium – Use for jeans, wrinkle free or “wash-and-wear” items and synthetics.

Low/Hang Dry – Use for delicate items needing a slow spin speed because of fabric and construction and for hang-dry items.

● Max Extract

● High

● Medium

● Low

Spin

Step 6

SELECT CYCLE OPTIONS

Press the appropriate pad(s) to select one or more options.

Set Delay Time – Allows the start of any cycle to be delayed for up to 9 hours. Make the appropriate selections for your load, then press the up or down arrows to increase or decrease the delay time from one to nine hours. Press the **Start/Pause** pad to start the delay time count-down. To cancel a delay, press Off and reselect the cycle.

Presoak – Adds 12 minutes of mostly soaking with minimal tumbling before the cycle. Can be selected with any cycle.

Extra Rinse – Adds an additional rinse at the end of the cycle to more thoroughly remove laundry additives and perfumes.

Signal – Press the signal pad to increase or decrease the end of cycle signal volume.

Set Delay Time

44

Estimated Time

Presoak

Extra Rinse

Signal

Cycle Options

OPERATING INSTRUCTIONS

Step 7

START YOUR MAYTAG NEPTUNE® TL WASHER

- Add detergent and additives to the dispensers (See pages 7-8).
- Close the lid.
- Press the **Start/Pause** pad.

NOTES:

- When the cycle is complete, the **Locked** light will go out. The lid will open easily. **DO NOT** attempt to open the washer when the **Locked** light is illuminated. To add a forgotten item, see page 3.
- When the washer is started after a pause, there **will be a pause of up to 20 seconds** before continuing the cycle.
- Pressing **Off** cancels the cycle and stops the washer.
- Some cycles are designed to tumble then pause. This is normal.



ESTIMATED TIME DISPLAY

When setting the cycle and pressing **Start/Pause**, the display will show the estimated minutes remaining in the cycle. The estimated time remaining may fluctuate to better indicate the wash time left in the cycle.



INDICATOR LIGHTS

Locked – lights whenever the lid of the clothes washer is locked. The lid can be unlocked by pressing the **Start/Pause** pad to pause the washer.

Pad Indicator Lights – the indicator lights next to the pads will illuminate when the pad is selected.

Cycle Status Lights – the Cycle Status Lights will illuminate to indicate where the washer is in the selected cycle.



WATER USE

The amount of water used will vary with each load. The Maytag Neptune® TL clothes washer uses an adaptive fill system to automatically provide the appropriate amount of water for efficient cleaning performance and conservation of water and energy. Fill time will vary depending on water pressure.

DETERGENT USE

Your Maytag Neptune® TL washer is designed to use either high efficiency (HE) detergents or regular detergents normally used with top-loading washers.



- For best cleaning results, use a high efficiency detergent such as Tide HE, Wisk HE, Cheer HE or Gain HE*. High efficiency detergents contain suds suppressors which reduce or eliminate suds. When less suds are produced, the load tumbles more efficiently and cleaning results are maximized.

- When using regular detergent formulated for top-loading washers, it is important to pay close attention to the soil level of the load, load size, and water hardness**. **To avoid over-sudsing, reduce the amount of detergent used with soft water or with small or lightly soiled loads.**

* Brand names are trademarks of the respective manufacturers.

** To determine water hardness in your area, contact your local water utility or State University Extension office in your area.

FEATURES

AUTOMATIC DISPENSERS

The washer has separate compartments for dispensing detergent and color-safe bleach, chlorine bleach and fabric softener. All laundry products can be added to their respective compartments before starting the washer.

The detergent dispenser **MUST ALWAYS** be in place before starting the washer.

DETERGENT DISPENSER

The Detergent Dispenser is located under the lid of the washer. There are two compartments in the dispenser; one for liquid detergent and liquid color-safe bleach, and one for powder detergent and powder color-safe bleach.

The dispenser will automatically dispense the detergent and color-safe bleach (if used) as the washer fills.

NOTE:

- When using color-safe bleach, add it to the appropriate dispenser compartment (liquid or powder) with the detergent. Do not mix liquids and powders in the same compartment of the dispenser.
- Do not place detergent or softener bottle lids, caps or dispensers into the washtub. Damage to the load or washer may result.

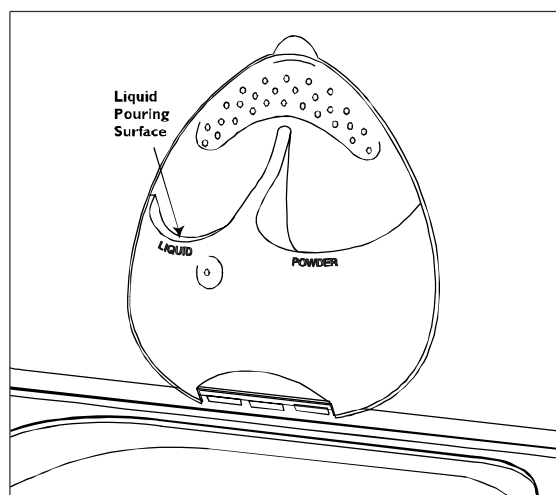

FEATURES

CHLORINE BLEACH DISPENSER

The Chlorine Bleach Dispenser is located on the left side of the washer tub. To use the dispenser:

1. Add chlorine bleach to the bleach compartment. **DO NOT** exceed the MAX FILL line. The liquid chlorine bleach compartment will hold 1/3 of a cup.
2. Avoid splashing or over-filling the compartment. **Over-filling the compartment will not damage the load but will release the liquid chlorine bleach into the clothes washer too early to be effective.**
3. The washer automatically dispenses bleach into the tub in the first rinse. This maximizes the effectiveness of the bleach.
4. The dispenser automatically dilutes liquid chlorine bleach before it reaches the wash load.

NOTES:

- Never pour undiluted liquid chlorine bleach directly onto the load or into the tub. It is a powerful chemical and can cause fabric damage, such as weakening of the fibers or color loss, if not used properly.
- If you prefer to use color-safe, non-chlorine bleach, add it to the appropriate detergent compartment. Do not pour color-safe bleach into the chlorine bleach dispenser.

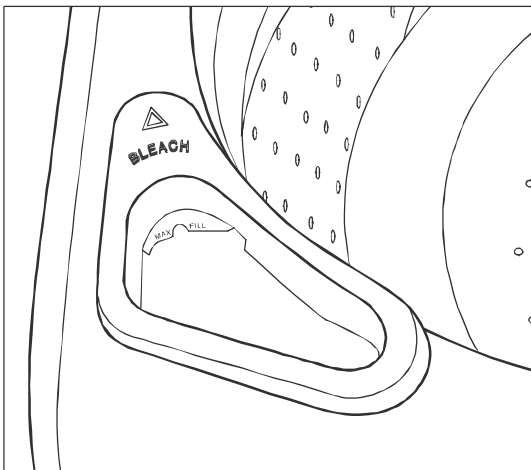

FABRIC SOFTENER DISPENSER

The Fabric Softener Dispenser is located on the right side of the washer tub. To use the dispenser:

1. Pour the recommended amount of liquid fabric softener into the softener compartment. For smaller loads use less than one cap full.
2. Fabric softener should be diluted with warm water until it reaches the MAX FILL line on the compartment. **Do not fill above the MAX FILL line. If the compartment is filled above the MAX FILL line, fabric softener will enter the clothes washer too early to be effective.**
3. This compartment automatically releases liquid fabric softener at the proper time during the final rinse portion of the cycle.

NOTES:

- Use the softener compartment only for liquid fabric softeners.
- Do not use the Downy Ball[®] with this washer. It will not add fabric softener at the appropriate time and may damage the washer. Use the dispenser in the washer.

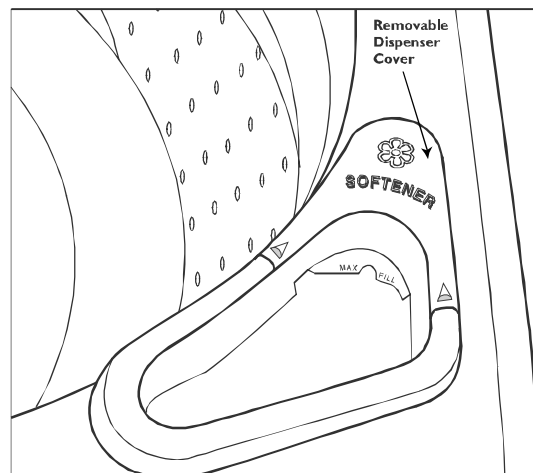

* Brand names are trademarks of the respective manufacturers.

CARE AND CLEANING

Turn off the water faucets after finishing the day's washing. This will shut off the water supply to the clothes washer and prevent the unlikely possibility of damage from escaping water.

Use a soft cloth to wipe up all detergent, bleach or other spills as they occur.

CLEANING THE INTERIOR

The interior of the washer should be cleaned periodically to remove dirt, soil, odor or bacteria residue that may remain in the washer as a result of washing clothes. We recommend taking the following steps every 60 to 120 days to clean and freshen your washer interior. The frequency with which the washer should be cleaned and freshened depends on factors such as usage, the amount of dirt, soil or bacteria being run through your washer, or the use of cold water.

CLEANING THE DISPENSERS

The Detergent, Fabric Softener and Bleach dispensers may need to be cleaned periodically due to laundry additive buildup.

Detergent Dispenser:

1. Remove the dispenser by releasing the top end from the lid with a quarter or something similar.
2. Take the dispenser to a sink.
3. Wash thoroughly with plain water and soft brush if necessary.
4. Rinse and dry the dispenser.
5. Replace dispenser in washer lid by fitting the bottom in first, then snapping the top all the way in.
6. DO NOT clean the dispenser in the dishwasher.

NOTE: The dispenser MUST ALWAYS be in place before starting the washer.

Chlorine Bleach Dispenser:

The dispenser cover is not removable.

Wipe thoroughly with a clean, damp cloth or paper towel.

Clean the following as recommended:

Control Panel – clean with a soft, damp cloth. Do not use abrasive powders or cleaning pads. Do not spray cleaners directly on the panel.

Cabinet – clean with soap and water.

To clean and freshen the washer interior:

1. Add a measured amount of chlorine bleach to the bleach dispenser, following package directions.
2. Run the washer through a complete cycle using hot wash water.
3. Repeat the process if necessary.

Fabric Softener Dispenser:

The rear portion of the fabric softener dispenser cover is removable for cleaning.

1. Grasp the rear portion of the cover and pull straight up.
2. Wash with hot, soapy water and a soft cloth. Rinse and dry thoroughly.
3. Wipe dispenser compartment with a dry paper towel to remove buildup. Follow with a clean, damp cloth or paper towel.
4. Replace dispenser cover.
5. DO NOT clean the dispenser cover in the dishwasher.

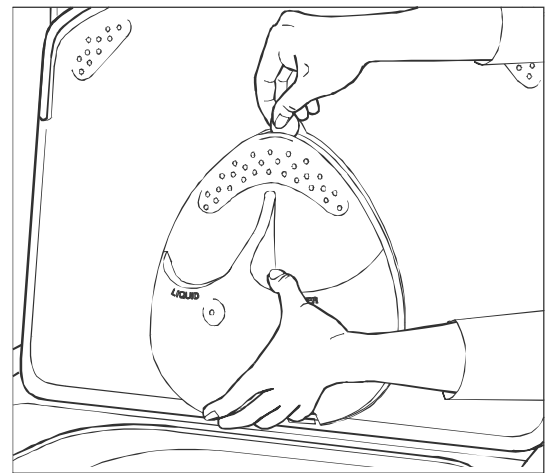

STORING THE CLOTHES WASHER

Washers can be damaged if water is not removed from hoses and internal components before storage. Prepare the washer for storage as follows:

- Select the **Normal Cycle** setting and add 1/3 cup of bleach to the bleach dispenser without clothes in the tumbler. Run the clothes washer through a complete cycle using hot water.

- Turn the water faucets off and disconnect the inlet hoses.
- Disconnect the clothes washer from the electrical supply and leave the washer lid open to let air circulate inside the tub.
- If the washer has been stored in below-freezing temperatures, allow time for any water left over in the washer to thaw out prior to use. This may take several hours.

TROUBLESHOOTING

For problem laundry solutions (i.e. fabric damage, residue, tangling) and special laundry care procedures, see the enclosed Laundering Tips booklet.

CHECK THESE POINTS IF YOUR MAYTAG NEPTUNE® TL WASHER...

Load is Too Wet at End of Cycle	<ul style="list-style-type: none"> • Use Max Extract option. • Try using a high efficiency detergent to reduce sudsing. • Load is too small. Very small loads (one or two items) may become unbalanced and not spin out completely. • Load is too large. Very large loads may not spin out completely.
Leaks Water	<ul style="list-style-type: none"> • Make sure hose connections are tight. • Make sure end of drain hose is correctly inserted and secured to drain facility. • If there is a drain restriction, call for service. • Avoid overloading. • Use high efficiency detergent to prevent over-sudsing.
Won't Spin or Drain	<ul style="list-style-type: none"> • Check fuse or reset circuit breaker. • Straighten drain hoses. Eliminate kinked hoses. If there is a drain restriction, call for service. • Open and close the lid and push the Start/Pause pad. For your safety, washer will not tumble or spin unless the lid is closed. • After pressing the Start/Pause pad, it may take up to one minute before the clothes washer begins to spin. The lid must lock before spin can be achieved. • See "Tub is Completely Full of Suds" page 11.
Stops	<ul style="list-style-type: none"> • Plug cord into live electrical outlet. • Check fuse or reset circuit breaker. • Open and close lid and push the Start/Pause pad to start the clothes washer. For your safety, washer will not tumble or spin unless lid is closed. • There may be a pause or soak period in the cycle. Wait briefly and it may start. • The washer is equipped with a lid switch failure detector. If the lid switch should malfunction, the detector will stop operation for your safety. Call for service. • Check screens on inlet hoses at the faucets for obstructions. Clean screens periodically, especially if you have new water lines or hard water.

TROUBLESHOOTING

CHECK THESE POINTS IF YOUR MAYTAG NEPTUNE® TL WASHER...

Tub is Completely Full of Suds	<ul style="list-style-type: none"> • Run the clothes washer through another complete cycle using cold water and no detergent. • Reduce detergent amount for that specific load size, soil level and water hardness. • Use high efficiency or low sudsing detergent specially formulated for high-efficiency washers.
Fills with the Wrong Temperature Water	<ul style="list-style-type: none"> • Turn both faucets on fully. • Make sure temperature selection is correct. • Make sure hoses are connected to correct faucets. Flush water lines. • Check the home's water heater. It should be set to deliver a minimum 120°F (49°C) hot water at the tap. Also check water heater capacity and recovery rate. • Disconnect hoses and clean screens. Hose filter screens may be plugged. • When warm rinse is selected, only the final rinse will be warm. The other rinses will be cold to conserve energy. • As the washer is filling, the water temperature may change as the automatic temperature control feature checks incoming water temperature. This is normal.
Won't Fill	<ul style="list-style-type: none"> • Be sure the lid is closed. • Plug cord into a live electrical outlet. • Check fuse or reset circuit breaker. • Press the Start/Pause pad. • Turn both faucets on fully. • Straighten inlet hoses. • Disconnect hoses and clean screens at faucets. Hose filter screens may be plugged. • Open and close the lid, then push the Start/Pause pad.
Won't Tumble	<ul style="list-style-type: none"> • Check fuse or reset circuit breaker. • Open and close the lid and press the Start/Pause pad. For your safety, the clothes washer will not tumble or spin unless the lid is closed. • Some cycles are designed to tumble and then pause. This is normal.
Lid Locked Shut; Will Not Open	<ul style="list-style-type: none"> • Press the Start/Pause pad to stop the washer. • It may take up to two minutes for the lid lock mechanism to disengage. • A locked lid may not unlock during a power outage.
Is Noisy	<ul style="list-style-type: none"> • Clothes washer should be leveled properly and sitting on a solid floor as outlined in installation instructions. • Check that the leveling leg lock nuts are tightened. • Be sure rubber feet are installed on leveling legs. • Weak floors can cause vibration and walking. • The load may be unbalanced. • For information on normal operating sounds, see page 13.
Freshening Your Washer	<ul style="list-style-type: none"> • See Cleaning the Interior, page 9.

For further assistance, call Maytag Customer Service toll-free at 1-888-4-MAYTAG (1-888-462-9824). U.S. customers using TTY for deaf, hearing impaired or speech impaired, call 1-800-688-2080.

TROUBLESHOOTING

INFORMATION CODES

Information codes may be displayed to help you better understand what is occurring with the washer.

Code Symbol	Meaning	Solution
FL	The washer failed to lock the lid.	Make sure nothing is obstructing the lid. Close the lid and restart the cycle.
PF	The washer experienced a power failure.	Restart the cycle. If code is still displayed, check to make sure power cord is securely plugged in.
nd	The washer experienced difficulty draining.	Check for a kinked drain hose. Check for a plugged stand pipe.
LO	The washer has repeatedly tried to unlock the lid but has been unsuccessful.	Make sure lid is firmly closed. Push the "Off" button and then wait four minutes for the lid to unlock. OR Unplug the washer for two minutes and plug back in.
Lr	Motor not running properly.	Call for service. See below.
nf	The washer has tried to fill, but has not reached the proper fill level.	Make sure the water faucets are open all the way. Check for kinked hoses. Check inlet screens on fill hoses.
UC	The washer cannot spin.	Call for service. See below.
dc	Unbalanced load prevented the washer from spinning.	Redistribute the load, then press Start/Pause .
LL	The washer cannot spin because the load is too large.	Remove some items from the tub and press Start/Pause . If removing items does not correct the problem, call for service. See below.
oL	The washer cannot tumble because something is blocking the tumblers.	Remove item from the tub. Press Start/Pause . OR Remove part of the load from the washer. Press Start/Pause . If removing item(s) does not correct the problem, call for service. See below.
OP	The washer lid is open.	The lid must be closed to start cycle. Close the lid and press Start/Pause .
od	The washer lid must be opened.	This is a safety feature. The lid must be opened before another cycle is started.

For any codes not listed above, call Maytag Neptune® Priority One Service at 1-888-462-9824. The dedicated Maytag Neptune® customer service representative will be able to assist you.

OPERATING SOUNDS

NORMAL OPERATING SOUNDS OF YOUR MAYTAG NEPTUNE® TL CLOTHES WASHER

<p>High pitched sound during a spin cycle.</p>	<p>The motor increases speed to spin the tub to remove moisture from the load.</p>
<p>“Whirring” sound followed by a pause, repeated throughout the wash cycle.</p>	<p>On some cycles, the tumbling stops and the washer pauses during the cleaning process.</p>
<p>Clothes washer maintains a slightly reduced spin speed after achieving a higher spin speed.</p>	<p>After reaching the maximum spin speed, the machine may reduce spin speed slightly for maximum performance.</p>
<p>The spin speed slows down dramatically when it sounds like an out-of-balance load.</p>	<p>The tumbler will begin to accelerate to speed, then slows back down and tumbles to redistribute the load more evenly when an unbalanced load occurs.</p>
<p>Water is added after the washer has been washing for a while.</p>	<p>The Maytag Neptune® clothes washer uses a true adaptive fill and adds more water during the wash cycle as it is needed.</p> <p style="text-align: center;">OR</p> <p>Water flows through the dispensers to dilute and add bleach or fabric softener at the appropriate time. This will occur even if bleach and fabric softener are not used.</p>
<p>Clicking/draining sounds when washer is started.</p>	<p>Before the washer starts to fill, it will make a clicking noise to lock the lid and do a quick drain.</p>



QUESTIONS & ANSWERS

Q. What's the best cycle to use if I have stains on my laundry?

- A.** For most fabrics, select the **Normal** cycle with the **Stain Treat** soil level. For heavy-duty fabrics, select the **Super Wash** cycle. Pretreat the stains with a laundry pre-treat product. Refer to the enclosed **Laundering Tips** booklet for more information on treating specific stains.

Q. How large of a load can I wash in my Maytag Neptune® washer?

- A.** The tub can be loaded loosely up to the top row of holes, but do not pack down the load. If the load is heavily soiled it is very important not to overload the washer.

Q. At the end of the cycle my load comes out wetter than normal. What causes this?

- A.** During tumble and spin, the washer may have had difficulty getting to a full spin speed because the load was not evenly distributed. This can occur with very small loads, heavy or bulky items or a load in which too much detergent was used, causing over-sudsing.

Q. My laundry items seem to be very wrinkled at the end of the cycle. What can I do to correct the problem?

- A.** Wrinkling is caused by the combination of heat and pressure. Be sure wrinkle free or permanent press fabrics are washed on the **Wrinkle Control** cycle, and a cold rinse is used. (See pg. 4 for WASH/RINSE Temperature). **DO NOT USE MAX-EXTRACT SPIN.**

Q. My whites are not as white as I'd like. What can I do?

- A.** Wash white loads using the **Whites** fabric selection. Select the hot wash/cold rinse temperature setting and put 1/3 cup of chlorine bleach in the bleach dispenser. The bleach will be dispensed in the first rinse to provide optimal whitening. Maytag recommends a hot water wash temperature of 120-140° F (49° - 60° C).



CLOTHES WASHER WARRANTY

Full One Year Warranty

For **one (1) year** from the date of original retail purchase, any part which fails in normal home use will be repaired or replaced free of charge.

Limited Warranty

After the first year from date of original retail purchase, through the time periods listed below, the parts designated below which fail in normal home use will be repaired or replaced free of charge for the part itself, with the owner paying all other costs, including labor, mileage, transportation, trip charge and diagnostic charge, if required.

Second Year – All parts.

Third through Fifth – The electronic console control board.

NOTE: This warranty does not include the motor control board, which is covered by the second year parts warranty only.

Third through Tenth – Drive motor, outer tub and sealed transmission.

Third through Lifetime – Stainless steel inner wash basket.

Additional Limited Warranty Against Rust-Through

Should an exterior cabinet, including the top and lid, rust through during the one year period starting from the date of retail purchase, repair or replacement will be made free of charge. After the first, and through the tenth year, repair or replacement will be made free of charge for the part itself, with the owner paying all other costs, including labor, mileage, transportation, trip charge and diagnostic charge, if required.

Please Note: This full warranty and the limited warranty apply when the washer is located in the United States or Canada.

Washers located elsewhere are covered by the limited warranty only, including parts which fail during the first two years.

The specific warranties expressed above are the **ONLY** warranties provided by the manufacturer. This warranty gives you specific legal rights, and you may also have other rights that vary from state to state.

To Receive Warranty Service

To locate an authorized service company in your area contact the Maytag dealer from whom your appliance was purchased; or call Maytag ServicesSM, Maytag Customer Assistance at the number listed below. Should you not receive satisfactory warranty service, please call or write:

Maytag ServicesSM

Attn: CAIR[®] Center

P.O. Box 2370

Cleveland, TN 37320-2370

U.S. or Canada (toll-free) 1-888-462-9824

U.S. customers using TTY for deaf, hearing impaired or speech impaired, call 1-800-688-2080.

When contacting Maytag ServicesSM, Maytag Customer Assistance about a service problem, please include the following:

- (a) Your name, address and telephone number.
- (b) Model number and serial number of your appliance.
- (c) Name and address of your dealer and the date the appliance was purchased.
- (d) A clear description of the problem you are having.
- (e) Proof of purchase.

What is not covered by these warranties:

1. Conditions and damages resulting from any of the following:
 - a. Improper installation, delivery or maintenance.
 - b. Any repair, modification, alteration or adjustment not authorized by the manufacturer or an authorized servicer.
 - c. Misuse, abuse, accidents or unreasonable use.
 - d. Incorrect electric current, voltage or supply.
 - e. Improper setting of any control.
2. Warranties are void if the original serial numbers have been removed, altered, or cannot be readily determined.

3. Products purchased for commercial or industrial use.
4. The cost of service or service call to:
 - a. Correct installation errors.
 - b. Instruct the user on proper use of the product.
 - c. Transport the appliance to the servicer.
5. Consequential or incidental damages sustained by any person as a result of any breach of these warranties.

Some states do not allow the exclusion or limitation of consequential or incidental damages, so the above exclusion may not apply.

Use & Care Guides, service manuals and parts catalogs are available from
Maytag ServicesSM, Maytag Customer Assistance.

Maytag • 403 West Fourth Street North • P. O. Box 39 • Newton, Iowa 50208



MAYTAG NEPTUNE® TL WASHER

USE & CARE

G U I D E

TABLE OF CONTENTS

Safety Instructions	1-2	Detergent Use.....	17
Operating Instructions.....	3	Features.....	17-18
Control Panel.....	4	Care & Cleaning.....	19-20
Set Your Own Cycle	5-6	Troubleshooting.....	21-22
Rinse or Spin Only.....	7-8	Operating Sounds	23
Favorites	9-11	Questions and Answers	24
Cycle Library	11-12	Warranty.....	25
Stain Brain	12	Guide de Utilisation et d'entretien.....	26
Using Help.....	13-16	Guía de Uso y Cuidado	53

Pour obtenir un affichage en français ou en espagnol, appuyer sur la touche Help (Aide), puis sur la zone (Sélection des préférences) et sélectionner la langue de votre choix.

Para cambiar el idioma de la pantalla a español o francés, oprima la tecla Help (Ayuda), oprima Select Preferences (Seleccionar Preferencias) y seleccione el idioma preferido.

Welcome

Welcome and congratulations on your purchase of a Maytag Neptune® TL washer! Your complete satisfaction is very important to us. For best results, we suggest reading this material to help acquaint you with proper operating and maintenance procedures.

Should you need assistance in the future, it is helpful to:

- 1) Have complete model and serial number identification of your washer. This is located on a data plate on the back right side of the control panel.

Date of Purchase _____
Model Number _____
Serial Number _____

- 2) **IMPORTANT:** Keep this guide and the sales receipt in a safe place for future reference. Proof of original purchase date is needed for warranty service.

If you have questions call:

Maytag Customer Assistance
1-888-462-9824 USA and CANADA
(Mon.–Fri., 8am–8pm Eastern Time)
Internet: <http://www.maytag.com>

U.S.A. customers using TTY for deaf, hearing impaired or speech impaired, call 1-800-688-2080

NOTE: In our continuing effort to improve the quality of our appliances, it may be necessary to make changes to the appliance without revising this guide.

For service and warranty information, see page 25.

IMPORTANT SAFETY INSTRUCTIONS

read before operating your washer

WHAT YOU NEED TO KNOW ABOUT SAFETY INSTRUCTIONS

Warning and Important Safety Instructions appearing in this manual are not meant to cover all possible conditions and situations that may occur. Common sense, caution, and care must be exercised when installing, maintaining or operating appliance.

Always contact your dealer, distributor, service agent, or manufacturer about problems or conditions you do not understand.

RECOGNIZE SAFETY SYMBOLS, WORDS, LABELS

WARNING

WARNING – Hazards or unsafe practices which **COULD** result in severe personal injury or death.

CAUTION

CAUTION – Hazards or unsafe practices which **COULD** result in minor personal injury.

WARNING

To reduce the risk of fire, explosion, electric shock property damage or injury to persons when using your appliance, follow basic precautions, including the following:

1. Read all instructions before using the appliance.
2. As with any equipment using electricity and having moving parts, there are potential hazards. To use this appliance safely, the operator should become familiar with the instructions for operation of the appliance and always exercise care when using it.
3. Do not install or store this appliance where it will be exposed to the weather.
4. Install and level washer on a floor that can support the weight.
5. This appliance must be properly grounded. Never plug the appliance cord into a receptacle which is not grounded adequately and in accordance with local and national codes. See installation instructions for grounding this appliance.
6. To avoid the possibility of fire or explosion:
 - a. Do not wash items that have been previously cleaned in, washed in, soaked in, or spotted with gasoline, dry-cleaning solvents, other flammable or explosive substances as they give off vapors that could ignite or explode. Hand wash and line dry any items containing these substances. Any material on which you have used a cleaning solvent, or which is saturated with flammable liquids or solids, should not be placed in the washer until all traces of these liquids or solids and their fumes have been removed.
These items include acetone, denatured alcohol, gasoline, kerosene, some liquid household cleaners, some spot removers, turpentine, waxes and wax removers.

- b. Do not add gasoline, dry-cleaning solvents, or other flammable or explosive substances to the wash water. These substances give off vapors that could ignite or explode.
 - c. Under certain conditions, hydrogen gas may be produced in a hot water system that has not been used for two weeks or more. **HYDROGEN GAS IS EXPLOSIVE**. If the hot water system has not been used for such a period, before using a washing machine or combination washer-dryer, turn on all hot water faucets and let the water flow from each for several minutes. This will release any accumulated hydrogen gas. As the gas is flammable, do not smoke or use an open flame during this time.
 - d. Do not wash or dry items that are soiled with vegetable or cooking oil. These items may contain some oil after laundering. Due to the remaining oil, the fabric may smoke or catch fire by itself.
7. Do not reach into the appliance if the tub or tumblers are moving.
 8. Do not allow children or pets to play on, in, or in front of the appliance. Close supervision is necessary when the appliance is used near children and pets.
 9. Do not tamper with controls.
 10. Do not repair or replace any part of the appliance or attempt any servicing unless specifically recommended in published user-repair instructions that you understand and have the skills to carry out.
 11. Unplug power supply cord before attempting to service your washer. Service is to be done only by qualified service personnel.
 12. Keep all laundry aids such as detergents, bleach, etc., out of the reach of children, preferably in a locked cabinet. Use laundry aids only as directed by the manufacturer. Observe all warnings on container labels.
 13. Keep the area around and underneath washer free from the accumulation of combustible materials, such as lint, paper, rags, gasoline, and all other flammable vapors and liquids.
 14. Do not use chlorine bleach and ammonia or acids (such as vinegar or rust remover) in the same wash. Hazardous fumes can form.
 15. Do not machine wash fiberglass materials. Small particles can stick to fabrics washed in following loads and cause skin irritation.
 16. For flame resistant finishes - follow garment manufacturer's instructions carefully. Improper laundering could remove the finish.
 17. Before the appliance is removed from service or discarded, remove the lid to the washing compartment.
 18. Inlet hoses are subject to damage and deterioration over time. Check the hoses periodically for bulges, kinks, cuts, wear or leaks and replace them every five years.

SAVE THESE INSTRUCTIONS

OPERATING INSTRUCTIONS

For detailed information on sorting, pretreating stains, etc., see the enclosed *Laundering Tips* booklet.

LOAD THE CLOTHES WASHER

- Put dry, unfolded clothes loosely in the tub, up to the top row of holes for a maximum load. Do not pack down the load.
- Overloading may reduce washing efficiency, cause excess wear and possibly cause creasing or wrinkling of the load.
- Wash delicate items such as bras, hosiery and other lingerie in the “delicates” or “hand wash” cycle with similar lightweight items.
- When washing smaller, bulky items that do not fill the tub completely such as a rug, one pillow, stuffed toys or one or two sweaters, a few towels should be added for improved tumbling and spin performance.
- DO NOT overload the washer when washing large, bulky items such as comforters, blankets or mattress pads. Items should fit loosely in the tub, below the top row of holes. Use the “bulky items” cycle for these loads. The “bulky items” cycle can be accessed by touching “cycle library” on the Home screen or use the Cycle Library option pad.
- When washing heavily soiled loads, it is very important to avoid overloading the washer to assure good cleaning results.
- To load a forgotten item, press the Start/Pause touchpad, wait for the Locked light to go out, add the item, close the lid and press the Start/Pause touchpad. After a pause of up to one minute, the cycle will resume.
- Close lid carefully to avoid slamming

NOTE:

- To assure that your additional items get clean, do not wait more than five minutes after the cycle has started to add the item.

STATUS DISPLAY

ESTIMATED TIME DISPLAY

After pressing Start, this display will show the estimated time remaining in the cycle. The estimated time may fluctuate to better indicate the wash time left in the cycle.

Lid Locked – Displays whenever the lid of the clothes washer is locked. The lid can be unlocked by pressing the Start/Pause touchpad to stop the washer.

WATER USE

The amount of water used will vary with each load. The Maytag Neptune® TL clothes washer uses an adaptive fill to provide the appropriate amount of water for efficient cleaning performance and conservation of water and energy. Fill time will vary depending on water pressure.

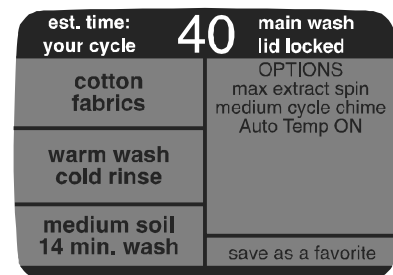

CONTROL PANEL

Touchscreen - An interactive display that responds with the touch of a finger.

Note: Exposure of the touchscreen to direct sunlight is not recommended.

Off - Stops the washer and the turns off the display.

Home - Takes you immediately to the first screen.

Start/Pause - Press this pad to start a cycle. Once started, pressing this pad will pause the washer at any point in the cycle.

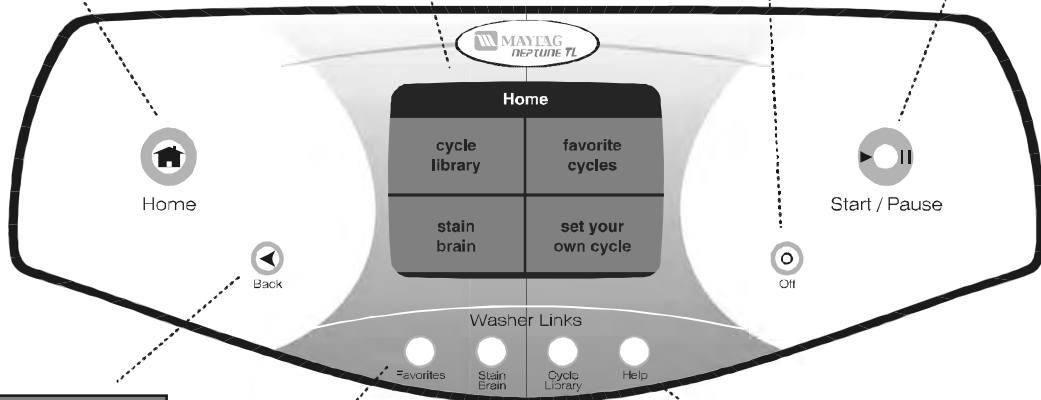

Back - Takes you to the previous screen.

Favorites - Quick access to your named cycles.

Stain Brain - Detailed steps to treat over 60 of the most common stains.

Help - Quick access to Fabric Care Symbols, Before You Call, Laundry Hints, Operating Tips, Lock Out Feature and Select Preferences.

Cycle Library - Use to quickly select and start preprogrammed wash cycles. Cycles are listed in alphabetical order.

Special Note: Press Back for previous touchscreen.

SET YOUR OWN CYCLE

If there are no words on the touchscreen, open the lid, touch any pad (except off), or touch the screen to “wake” the controls.

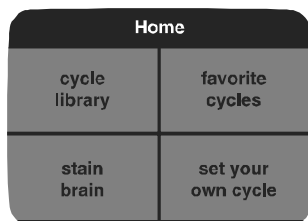

Step 1

Home Screen – Touch “set your own cycle” on the Home screen.



Step 2

Fabrics – Select the appropriate fabric setting for the type of load. This will determine the tumble or tumble/pause pattern for the load.

“sturdy” – For sturdy, color-fast and heavily soiled items.

“cottons” – For most normally soiled items including cottons, sheets, linens, underwear and t-shirts.

“wrinkle free” – For dress shirts/pants, wrinkle free clothing, poly/cotton blend clothing and jeans.

“delicates” – For dress shirts/blouses, nylons, sheer or lacy garments and lingerie.

“hand wash” – For items labeled hand wash.

“rinse or spin only cycles” – See pages 7-8.

NOTE:

- To minimize wrinkling of wrinkle free fabrics, select the “wrinkle free” fabrics setting. The “max extract” spin option is not recommended.
- Wash delicate items such as bras, hosiery and other lingerie in the “delicates” or “hand wash” cycle with similar lightweight items.



Step 3

Wash/Rinse Temperature – Select the appropriate wash/rinse temperature.

“hot/cold” – Whites and heavily soiled color-fast items.

“warm/warm” – Color-fast items. When warm rinse is selected, only the final rinse will be warm. The other rinses will be cold to conserve energy.

“warm/cold” – Moderately soiled color-fast items; most wrinkle free items.

“cold/cold” – Brightly colored, lightly soiled items; washable woolsens.

“tap cold/cold” – Uses cold water from the tap. Auto Temp will not heat (see page 6).

IMPORTANT: The washer features an automatic temperature control to provide a warm wash of approximately 105° F and cold wash of approximately 85° F

Soil Level/Wash Time	
stain treat 24 min. wash	
heavy soil 19 min. wash	medium soil 14 min. wash
light soil 9 min. wash	freshen 4 min. wash

Step 4

Soil Level/Wash Time – Select the appropriate soil level/wash time.

Press "Start/Pause" or change your selections below.	
cotton fabrics	OPTIONS max extract spin medium cycle chime Auto Temp ON
warm wash cold rinse	
medium soil 14 min. wash	
save as a favorite	



Start / Pause

Step 5

Review Screen – This screen reviews your selections before starting the washer. You may press Start/Pause to begin washing or press a displayed choice to change previous selections.

Options	
extra rinse on off	medium end of cycle chime
presoak on off	max extract spin
Auto Temp on off	delay wash on off
remind chime on off	continue

Step 6

Options Screen – The option choices turn the options on or off. Some option choices show an additional screen with multiple choices. When the desired selections are made, touch “continue” to see the review screen once again.



Start / Pause

Step 7

If you are satisfied with the selections, press the Start/Pause pad to begin the cycle.

“stain treat” – Use for cleaning ground-in, stubborn soils and stains.

“heavy soil” – Use for cleaning heavily soiled loads.

“medium soil” – Use for cleaning moderately soiled loads. This setting will be appropriate for most loads.

“light soil” – Use for cleaning lightly soiled loads.

“freshen” – The freshen setting offers a quick cycle time. Suggested uses include freshening newly purchased clothes or clothing that has been packed away.

“extra rinse” – An additional rinse at the end of the cycle to more completely remove laundry additives and perfumes.

“end of cycle chime” – Touch “loud”, “medium”, “soft” or “off” to set the volume level of the end of cycle chime. Touch “continue” to accept the selected volume setting.

“presoak” – Adds 12 minutes of mostly soaking with minimal tumbling at the start of the wash cycle. Can be selected with any cycle.

“spin” – This allows the proper spin speed selection for specific loads. “max extract” should be selected for towels and bedding. Select “medium” for khakis, jeans, dress shirts and other permanent press or wrinkle free items. Select “high (flat dry)” for underwear, t-shirts and sturdy cottons or for items that will be laid to dry and select “low (hang dry)” for delicate items needing a slow spin speed because of fabric and construction and for hang dry items.

NOTE:

- To minimize wrinkling of wrinkle free fabrics, select the “medium” spin selection.
-

“Auto Temp” – Uses an internal heater to provide the best water temperature and wash results. The cycle time may be extended while the washer heats the water. While heating, the washer will not tumble.

“delay wash” – Allows the start of any cycle to be delayed for up to 12 hours. Touch the up or down arrow under hour and minutes to set the time.

“remind chime” – When on, the washer will chime at the end of the cycle every 5 minutes for 2 hours or until the lid is opened.

Special Note: Press Back for previous touchscreen.

RINSE OR SPIN ONLY

Rinse or Spin Only offers the ability to choose a rinse and spin only cycle or a spin only cycle.

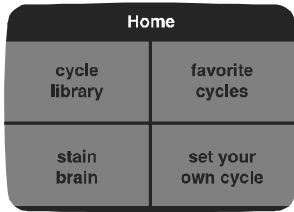

Step 1

Touch “set your own cycle” on the Home screen.

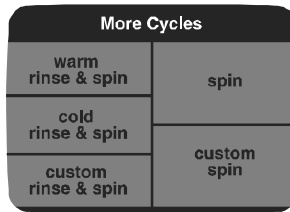

Step 2

Select “rinse or spin only cycles”. These settings allow you to choose from the following:

- “warm rinse & spin”
- “cold rinse & spin”
- “custom rinse & spin”
- “spin”
- “custom spin”

WARM RINSE & SPIN

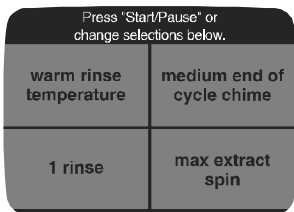

This screen reviews the preset selection for a “warm rinse & spin”. Press Start/Pause to begin rinsing or press a displayed choice to change a selection.

COLD RINSE & SPIN

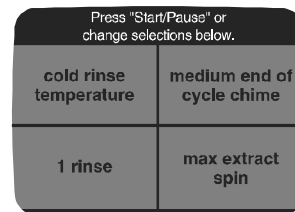

This screen reviews the preset selection for a “cold rinse & spin”. Press Start/Pause to begin rinsing or press a displayed choice to change a selection.

SPIN

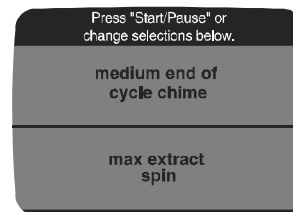

This screen reviews the preset selection for a “spin”. Press Start/Pause to begin spinning or press a displayed choice to change a selection.

CUSTOM RINSE & SPIN

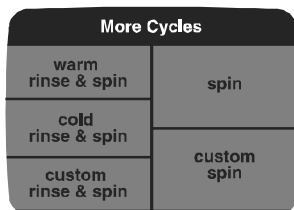

Step 1

Touch “custom rinse & spin” on the More Cycles Screen.

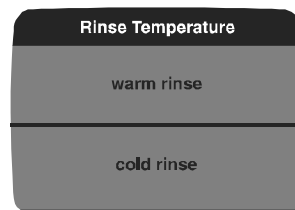

Step 2

Select the appropriate rinse temperature. A warm rinse may feel better for those with arthritic hands but uses more energy than a cold rinse.

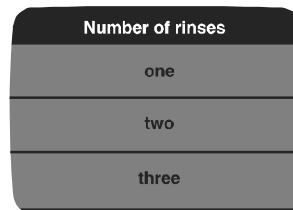

Step 3

Select the number of rinses appropriate for the load.

Spin Speeds	
max extract	high (flat dry)
medium	low (hang dry)

Press "Start/Pause" or change selections below.	
warm rinse temperature	medium end of cycle chime
2 rinses	max extract spln

Step 4

Select a spin speed appropriate for the load. This will determine how much moisture is removed from the load.

- “max extract”
- “high (flat dry)”
- “medium”
- “low (hang dry)”

See page 6 for descriptions of the spin cycles.

Step 5

This screen reviews the selections for “custom rinse & spin”. Press Start/Pause to begin rinsing or press a displayed choice to change a selection.

CUSTOM SPIN

More Cycles	
warm rinse & spin	spin
cold rinse & spin	
custom rinse & spin	custom spin

Spin Speeds	
max extract	high (flat dry)
medium	low (hang dry)

Press "Start/Pause" or change selections below.
medium end of cycle chime
max extract spin

Step 1

Touch “custom spin” on the More Cycles Screen.

Step 2

Select a spin speed appropriate for the load. This will determine how much moisture is removed from the load.

Step 3

This screen reviews the selections for a “custom spin”. Press Start/Pause to begin spinning or press a displayed choice to change a selection.

Special Note: Press Back for previous touchscreen.

FAVORITES

Favorites allows you to create, name and save up to 24 commonly used wash cycles. For a detailed description of the settings, see Set Your Own Cycle on pages 5 and 6.

“blue jeans” and “towels” favorite cycles have been programmed for you. To change these cycles for your preferences, see Edit a Favorite on page 10.

CREATE A FAVORITE

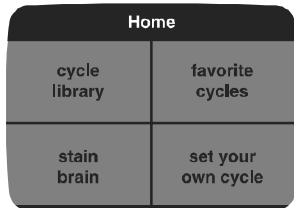

or Favorites



Step 1

Touch “favorite cycles” on the Home screen or use the Favorites option pad.

Step 2

Touch “create a favorite”.

Step 3

Fabrics – Select the appropriate fabric setting.

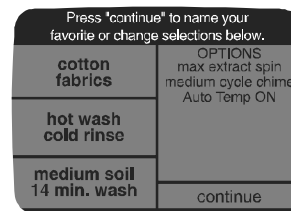
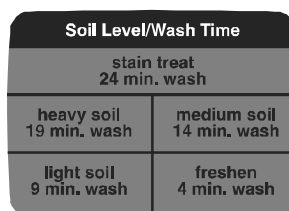
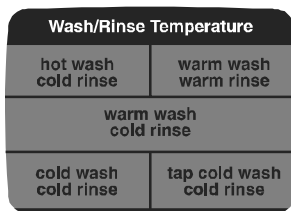

Step 4

Wash/Rinse Temperature – Select the appropriate wash/rinse temperature.

Step 5

Soil Level/Wash Time – Select the appropriate soil level/wash time.

Step 6

Review Screen – This screen reviews your cycle choices and allows you to choose Options to further customize your wash cycle. Press “options” if desired, or press “continue”.

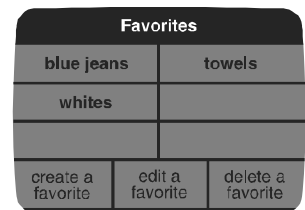
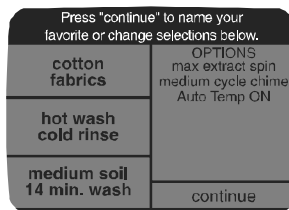

Step 7

Options Screen – The option choices turn the options on or off. Some option choices show an additional screen with multiple choices. When the desired selections are made, touch “continue” to see the review screen once again.

Step 8

If satisfied with your selections, press “continue” to name your favorite cycle.

Step 9

Name the Favorite Cycle – Touch the corresponding letter and space combination to spell out your favorite cycle name, up to 12 characters. Press “save”. Your new Favorite Cycle will be displayed on the Favorites pages.

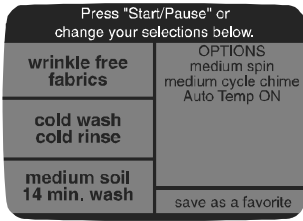

NOTE:

- The original Cycle Library cycle settings will remain the same. To save the new settings, select “save as a favorite” on the review screen.



Start / Pause

Step 3

The review screen for the selected cycle will be displayed. Any of the settings can be changed as needed.

Step 4

Press Start/Pause to begin the cycle.

STAIN BRAIN

The “stain brain” provides detailed steps to treat over 60 of the most common stains. The “stain brain” also offers the user the option of automatically setting the washer cycle for the particular stain.

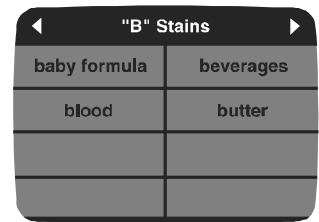
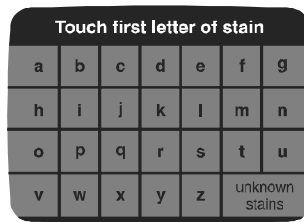
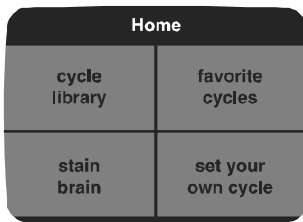

Step 1

Touch “stain brain” on the Home screen or use the Stain Brain option pad.

Step 2

Select the first letter of the stain.

Step 3

Select the appropriate stain listing.

NOTE:

- Use the arrows at the top of the screen to scroll from letter to letter.

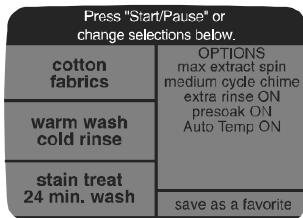
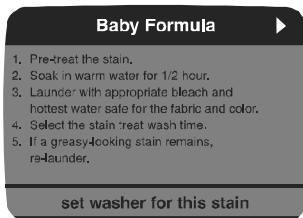

Start / Pause

Step 4

To automatically set the washer to run the appropriate cycle for the selected stain, touch “set washer for this stain”.

Step 5

Review Screen - This screen reviews the selections made by the “stain brain” before starting the washer. Some settings may need to be adjusted depending on the garment/fabric being washed. Follow garment care instructions as appropriate. Press Start/Pause to begin washing, or press a displayed choice to change selections.

USING HELP

The Help feature offers a variety of detailed information including “fabric care symbols”, “before you call”, “laundry hints”, “operating tips”, “lock out feature” and “select preferences”.

This section of the use and care guide will demonstrate how to easily navigate to the main areas of the help topics. From there, you will easily be able to narrow your search for finding laundry information.

FABRIC CARE SYMBOLS

Most garments and fabrics carry fabric care symbols on the care label. The “fabric care symbols” feature lists the symbols and what they mean.



Step 1

Touch the Help option pad.

Step 2

Select “fabric care symbols”.

Step 3

Select the symbol to be displayed.

Step 4

To see other symbols, press Back.

BEFORE YOU CALL

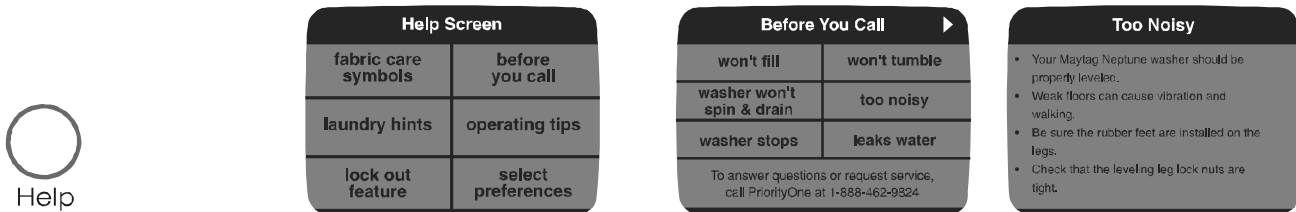

Step 1

Touch the Help option pad.

Step 2

Select “before you call”.

Step 3

Here you will see headings for common trouble-shooting topics. Touch one of the displayed areas to see specific information. Touch the arrows at the top of the screen to move forward or back through the topics. For more detailed information see Troubleshooting on pages 21-22, or call 1-888-462-9824 for further assistance.



Step 4

If you would like to see the other topics, press the Back touchpad to get back to the main topics.

Special Note: Press Back for previous touchscreen.

LAUNDRY HINTS



Step 1

Touch the Help option pad.

Help Screen	
fabric care symbols	before you call
laundry hints	operating tips
lock out feature	select preferences

Step 2

Select “laundry hints” from the Help screen.

Laundry Hints	
washer additives	washer sorting
detergents	pre-treating
water temperature	cycles
dryer hints	

Step 3

Here you will see the available topics. Touch the topics to see specific information.

Washer Additives	
color-safe bleach	
chlorine bleach	fabric softener
starch	bluing

Color-Safe Bleach
<ul style="list-style-type: none"> Color-safe bleach should be added in with detergent at the beginning of the cycle for most benefit. Color-safe bleach can be used on most items. It is most effective when used with a warm or hot water wash.



Step 4

Touch the sub-topic to see specific information.

Step 5

If you would like to see the other topics, press the Back touchpad to get back to the main topics.

OPERATING TIPS



Step 1

Touch the Help option pad.

Help Screen	
fabric care symbols	before you call
laundry hints	operating tips
lock out feature	select preferences

Step 2

Select “operating tips” from the Help Screen.

Operating Tips	
dispensers	control panel
control settings	unique sounds
washer care	

Step 3

“operating tips” provides information on maximizing the touchscreen controls and use of your washer.



Step 4

If you would like to see the other topics, press the Back touchpad to get back to the main topics.

USING HELP

LOCK OUT FEATURE



Step 1

Touch the Help option pad.

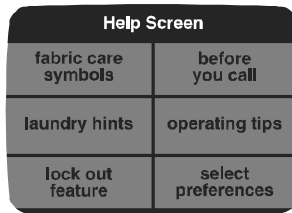

Step 2

Select “lock out feature” from the Help Screen.



Step 3

The “lock out feature” deactivates the touchscreen and touchpads. Press and hold the “To activate lock out press here” section for three seconds. Use this feature for cleaning the control panel or to prevent unwanted use of the washer.

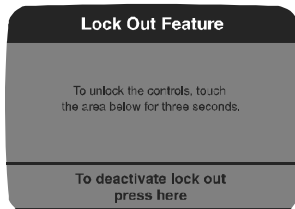

Step 4

To make the touchscreen and touchpads active again, press and hold the “To deactivate lock out press here” section for three seconds.



Step 5

If you would like to see the other topics, press the Back touchpad to get back to the main topics.

SELECT PREFERENCES



Step 1

Touch the Help option pad.

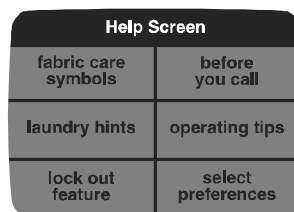

Step 2

Touch “select preferences”. “select preferences” allows you to select the volume of the touchscreen beeps, set the intensity of the screen display, activate the “auto start” and “screen saver” functions, and change the display language to English, French or Spanish.

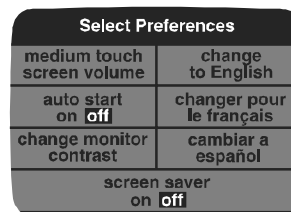

Special Note: Press Back for previous touchscreen.

TOUCHSCREEN VOLUME

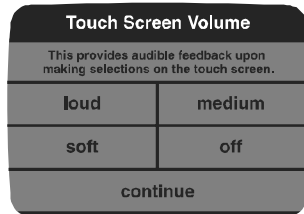

Touch "loud", "medium", "soft" or "off" to set the volume level of the touchscreen beeps. Touch "continue" to accept the selected volume setting.

CHANGE MONITOR CONTRAST

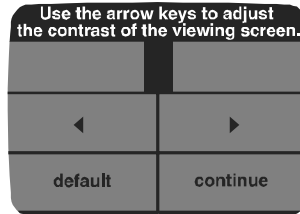

Depending on the lighting in your home and other factors, you may want to adjust the intensity of your touchscreen. Touch the arrows to lighten or darken the display. Touch "continue" when finished.

CHANGE LANGUAGE



You have the ability to change the language between English, French and Spanish. You will always see the next screen in the selected language to make sure you want to change the language.

AUTO START

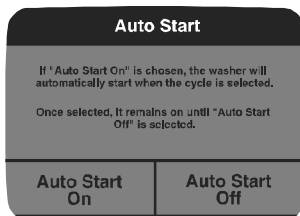

When "Auto Start On" is chosen, the washer will automatically start without pressing the Start/Pause pad when the cycle is selected.

SCREEN SAVER

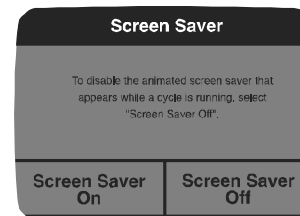

Selecting "Screen Saver On" activates the animated screen saver that appears when a cycle is running. To disable the screen saver, select "Screen Saver Off".



Special Note: Press Back for previous touchscreen.

DETERGENT USE

Your Maytag Neptune® TL washer is designed to use either high efficiency (HE) detergents or regular detergents normally used with top-loading washers.



- For best cleaning results, use a high efficiency detergent such as Tide HE, Wisk HE, Cheer HE or Gain HE*. High efficiency detergents contain suds suppressors which reduce or eliminate suds. When less suds are produced, the load tumbles more efficiently and cleaning results are maximized.

- When using regular detergent formulated for top-loading washers, it is important to pay close attention to the soil level of the load, load size, and water hardness**. To avoid over-sudsing, reduce the amount of detergent used with soft water or with small or lightly soiled loads.

* Brand names are trademarks of the respective manufacturers.

** To determine water hardness in your area, contact your local water utility or State University Extension office in your area.

FEATURES

AUTOMATIC DISPENSERS

The washer has separate compartments for dispensing detergent and color-safe bleach, chlorine bleach and fabric softener. All laundry products can be added at once in their respective compartments before starting the washer.

The detergent dispenser **MUST ALWAYS** be in place before starting the washer.

DETERGENT DISPENSER

The Detergent Dispenser is located under the lid of the washer. There are two compartments in the dispenser, one for liquid detergent and liquid color-safe bleach, and one for powder detergent and powder color-safe bleach.

The dispenser will automatically dispense the detergent and color-safe bleach (if used) as the washer fills.

NOTES:

- When using color-safe bleach, add it to the appropriate dispenser compartment (liquid or powder) with the detergent. Do not mix liquids and powders in the same compartment of the dispenser.
- Do not place detergent or softener bottle lids, caps or dispensers into the washtub. Damage to the load or washer may result.

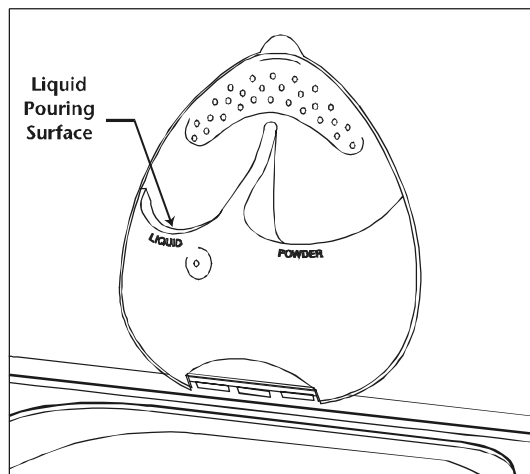

CHLORINE BLEACH DISPENSER

The Chlorine Bleach Dispenser is located on the left side of the washer tub. To use the dispenser:

1. Add chlorine bleach to the bleach compartment. **DO NOT** exceed the **MAX FILL** line. The liquid chlorine bleach compartment will hold 1/3 of a cup.
2. Avoid splashing or over-filling the compartment. Over-filling the compartment will not damage the load but will release the liquid chlorine bleach into the clothes washer too early to be effective.
3. The washer automatically dispenses bleach into the tub in the first rinse. This maximizes the effectiveness of the bleach.
4. The dispenser automatically dilutes liquid chlorine bleach before it reaches the wash load.

NOTES:

- Never pour undiluted liquid chlorine bleach directly onto the load or into the tub. It is a powerful chemical and can cause fabric damage, such as weakening of the fibers or color loss, if not used properly.
- If you prefer to use color-safe, non-chlorine bleach, add it to the appropriate detergent compartment. Do not pour color-safe bleach into the chlorine bleach dispenser.

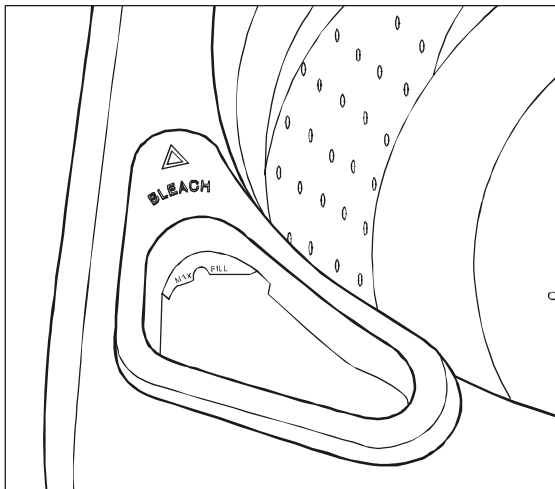

FABRIC SOFTENER DISPENSER

The Fabric Softener Dispenser is located on the right side of the washer tub. To use the dispenser:

1. Pour the recommended amount of liquid fabric softener into the softener compartment. For smaller loads use less than one cap full.
2. Fabric softener should be diluted with warm water until it reaches the **MAX FILL** line on the compartment. Do not fill above the **MAX FILL** line. If the compartment is filled above the **MAX FILL** line, fabric softener will enter the clothes washer too early to be effective.
3. This compartment automatically releases liquid fabric softener at the proper time during the final rinse portion of the cycle.

NOTES:

- Use the softener compartment only for liquid fabric softeners.
- Do not use the Downy Ball* with this washer. It will not add fabric softener at the appropriate time and may damage the washer. Use the dispenser in the washer.

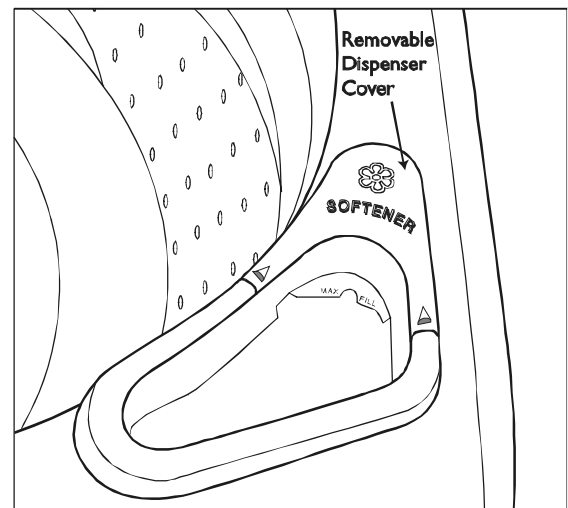

* Brand names are trademarks of the respective manufacturers.

CARE AND CLEANING

Turn off the water faucets after finishing the day's washing. This will shut off the water supply to the clothes washer and prevent the unlikely possibility of damage from escaping water.

Use a soft cloth to wipe up all detergent, bleach or other spills as they occur.

Clean the following as recommended:

Control Panel – clean with a soft, damp cloth. Do not use abrasive powders or cleaning pads. Do not spray cleaners directly on the panel.

Cabinet – clean with soap and water.

CLEANING THE INTERIOR

The interior of the washer should be cleaned periodically to remove dirt, soil, odor or bacteria residue that may remain in the washer as a result of washing clothes. We recommend taking the following steps every 60 to 120 days to clean and freshen your washer interior. The frequency with which the washer should be cleaned and freshened depends on factors such as usage, the amount of dirt, soil or bacteria being run through your washer, or the use of cold water.

To clean and freshen the washer interior:

1. Add a measured amount of chlorine bleach to the bleach dispenser, following package directions.
2. Run the washer through a complete cycle using hot wash water.
3. Repeat the wash cycle if necessary.

CLEANING THE DISPENSERS

The Detergent, Fabric Softener and Bleach dispensers may need to be cleaned periodically due to laundry additive buildup.

Detergent Dispenser:

1. Remove the dispenser by releasing the top end from the lid with a quarter or something similar.
2. Take the dispenser to a sink.
3. Wash thoroughly with plain water and soft brush if necessary.
4. Rinse and dry the dispenser.
5. Replace dispenser in washer lid by fitting the bottom in first, then snapping the top all the way in.
6. DO NOT clean the dispenser in the dishwasher.

Chlorine Bleach Dispenser:

The dispenser cover is not removable.

Wipe thoroughly with a clean, damp cloth or paper towel.

Fabric Softener Dispenser:

The rear portion of the fabric softener dispenser cover is removable for cleaning.

1. Grasp the rear portion of the cover and pull straight up.
2. Wash with hot, soapy water and a soft cloth. Rinse and dry thoroughly.
3. Wipe dispenser compartment with a dry paper towel to remove buildup. Follow with a clean, damp cloth or paper towel.
4. Replace dispenser cover.
5. DO NOT clean the dispenser cover in the dishwasher.

NOTE:

- The dispenser MUST ALWAYS be in place before starting the washer.

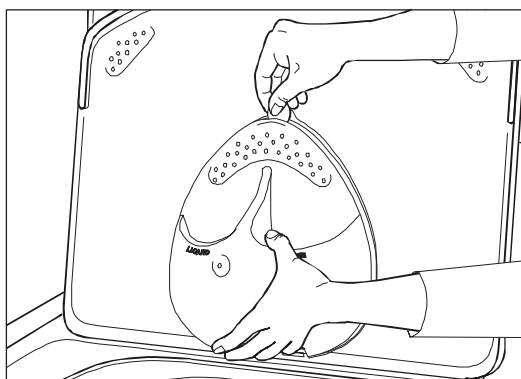

STORING THE CLOTHES WASHER

Washers can be damaged if water is not removed from hoses and internal components before storage. Prepare the washer for storage as follows:

- Select the “cottons” cycle setting and add 1/3 cup of bleach to the bleach dispenser without clothes in the tumbler. Run the clothes washer through a complete cycle.
- Turn the water faucets off and disconnect the inlet hoses.
- Disconnect the clothes washer from the electrical supply and leave the washer lid open to let air circulate inside the tub.
- If the washer has been stored in below-freezing temperatures, allow time for the water left over in the washer to thaw out prior to use. This may take several hours.

For information on long-term storage or storage of your washer during extreme cold temperatures, call Maytag Customer Service toll-free at 1-888-462-9824.

U.S. customers using TTY for deaf, hearing impaired or speech impaired, call 1-800-688-2080.

TROUBLESHOOTING

For problem laundry solutions (i.e. fabric damage, residue, tangling) and special laundry care procedures, see the enclosed Laundering Tips booklet.

CHECK THESE POINTS IF YOUR MAYTAG NEPTUNE® TL CLOTHES WASHER...

Load is Too Wet at End of Cycle	<ul style="list-style-type: none"> • Use “max extract” spin speed option. • Try using a high efficiency detergent to reduce sudsing. • Load is too small. Very small loads (one or two items) may not be balanced and may not spin out completely. • Load is too large. Very large loads may not spin out completely.
Leaks Water	<ul style="list-style-type: none"> • Make sure hose connections are tight. • Make sure end of drain hose is correctly inserted and secured to drain facility. • If there is a drain restriction, call for service. • Avoid overloading. • Use high efficiency detergent to prevent over-sudsing.
Won't Spin or Drain	<ul style="list-style-type: none"> • Check fuse or reset circuit breaker. • Straighten drain hoses. Eliminate kinked hoses. If there is a drain restriction, call for service. • Open and close the lid, then push the Start/Pause touchpad. For your safety, washer will not tumble or spin unless the lid is closed. • After pressing the Start/Pause touchpad, it may take up to 1 minute before the clothes washer begins to spin. The lid must lock before spin can be achieved. • See “Tub is Completely Full of Suds” below.
Stops	<ul style="list-style-type: none"> • Plug cord into live electrical outlet. • Check fuse or reset circuit breaker. • Open and close the lid, then push the Start/Pause touchpad to start the clothes washer. For your safety, washer will not tumble or spin unless lid is closed. • There may be a pause or soak period in the cycle. Wait briefly and it may start. • Check screens on inlet hoses at the faucets for obstructions. Clean screens periodically. • The washer is equipped with a lid switch failure detector. If the lid switch should malfunction, the detector will stop operation for your safety. Call for service.
Tub is Completely Full of Suds	<ul style="list-style-type: none"> • Run the clothes washer through another complete cycle using cold water and no detergent. • Reduce detergent amount for that specific load size, soil level and water hardness. • Use high efficiency or low sudsing detergent specially formulated for high efficiency washers.
Fills with the Wrong Temperature Water	<ul style="list-style-type: none"> • Turn both faucets on fully. • Make sure temperature selection is correct. • Make sure hoses are connected to correct faucets. Flush water lines. • Check the home's water heater. It should be set to deliver a minimum 120°F (49°C) hot water at the tap. Also check water heater capacity and recovery rate. • Disconnect hoses and clean screens. Hose filter screens may be plugged. • When warm rinse is selected, only the final rinse will be warm. The other rinses will be cold to conserve energy. • As the washer is filling, the water temperature may change as the automatic temperature control feature checks incoming water temperature. This is normal.

CONTINUED

CHECK THESE POINTS IF YOUR MAYTAG NEPTUNE® TL CLOTHES WASHER...

Won't Fill	<ul style="list-style-type: none"> • Be sure the lid is closed. • Plug cord into a live electrical outlet. • Check fuse or reset circuit breaker. • Open and close the lid, then push the Start/Pause touchpad. • Turn both faucets on fully. • Straighten inlet hoses. • Disconnect hoses and clean screens. Hose filter screens may be plugged.
Won't Tumble	<ul style="list-style-type: none"> • Check fuse or reset circuit breaker. • Open and close the lid, then press the Start/Pause touchpad. For your safety, the clothes washer will not tumble or spin unless the lid is closed. • Some cycles are designed to tumble then pause. This is normal.
Lid Locked Shut; Will Not Open	<ul style="list-style-type: none"> • Press the Start/Pause touchpad to stop the washer. • It may take up to 2 minutes for the lid lock mechanism to disengage. • A locked lid may not unlock during a power outage.
Is Noisy	<ul style="list-style-type: none"> • Clothes washer should be leveled properly as outlined in installation instructions. • Check that the leveling leg lock nuts are tightened. • Be sure rubber feet are installed on leveling legs. • Weak floors can cause vibration and walking. • The load may be unbalanced. • For information on normal operating sounds, see page 23.
The Touchscreen is Fading	<ul style="list-style-type: none"> • The contrast may need to be adjusted. Select the Help option pad then "select preferences". Touch "change monitor contrast". Using the arrows move the block to the left or right to improve the visual quality of the touchscreen.
Freshening Your Washer	<ul style="list-style-type: none"> • See Cleaning the Interior, page 19.

POP-UP WINDOWS

In an effort to better understand what is occurring with your Maytag Neptune® TL Washer, pop-up windows may appear. These windows are there to inform you of what is happening and what actions may need to be taken. Examples of these pop-up windows are below.

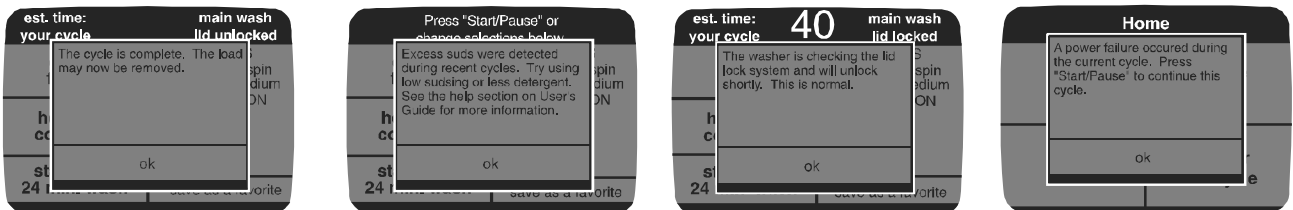

After you have read the message, touch "ok" and the pop up window will disappear.

For further assistance, call Maytag Customer Service toll-free at 1-888-4-MAYTAG (1-888-462-9824). U.S. customers using TTY for deaf, hearing impaired or speech impaired, call 1-800-688-2080.

OPERATING SOUNDS

NORMAL OPERATING SOUNDS OF YOUR MAYTAG NEPTUNE® TL CLOTHES WASHER

<p>High pitched sound during a spin cycle.</p>	<p>The motor increases speed to spin the tub to remove moisture from the load.</p>
<p>“Whirring” sound followed by a pause, repeated throughout the wash cycle.</p>	<p>On some cycles, the tumbling stops and the washer pauses during the cleaning process.</p>
<p>Clothes washer maintains a slightly reduced spin speed after achieving a higher spin speed.</p>	<p>After reaching the maximum spin speed, the washer may reduce spin speed slightly for maximum performance.</p>
<p>The spin speed slows down dramatically when it sounds like an out-of-balance load.</p>	<p>The tumbler will begin to accelerate to speed, then slows back down and tumbles to redistribute the load more evenly when an unbalanced load occurs.</p>
<p>Water is added after the washer has been tumbling for a while.</p>	<p>The Maytag Neptune® TL clothes washer uses a true adaptive fill and adds more water during the wash cycle as it is needed. OR Water flows through the dispensers to dilute and add bleach or fabric softener at the appropriate time. This will occur even if bleach and fabric softener are not used.</p>
<p>Clicking/draining sounds when washer is started.</p>	<p>Before the washer starts to fill, it will make a clicking noise to lock the lid and do a quick drain.</p>

QUESTIONS & ANSWERS

Q. What's the best cycle to use if I have stains on my laundry?

A. For most fabrics, select the "cottons" fabric selection, the "stain treat" soil level/wash time and the hottest water temperature appropriate for the fabric. For heavy duty fabrics, select the "sturdy" fabric selection. Pretreat the stains with a laundry pre-treat product. Refer to the Stain Brain option for more information on treating specific stains.

Q. How large of a load can I wash in my Maytag Neptune® TL washer?

A. The tub can be loaded loosely up to the top row of holes but do not pack down the load. If the load is heavily soiled it is very important not to overload the washer.

Q. At the end of the cycle my load comes out wetter than normal. What causes this?

A. During tumble and spin, the washer may have had difficulty getting to a full spin speed because the load was not evenly distributed. This can occur with very small loads, heavy or bulky items or a load in which too much detergent was used, causing over-sudsing.

Q. My laundry items seem to be very wrinkled at the end of the cycle. What can I do to correct the problem?

A. Wrinkling is caused by the combination of heat and pressure. Be sure wrinkle free or permanent press fabrics are washed on the "wrinkle control" cycle, "medium" spin, and a "cold rinse" is used. (See page 5 for Wash/Rinse Temperature). **DO NOT USE MAX-EXTRACT.**

Q. My whites are not as white as I'd like. What can I do?

A. Wash white loads using the "cottons" fabric selection. Select the "hot wash/cold rinse" temperature setting and put 1/3 cup of chlorine bleach in the bleach dispenser. The bleach will be dispensed in the first rinse to provide optimal whitening. Maytag recommends a hot water wash temperature of 120-140° F (49°- 60° C).



CLOTHES WASHER WARRANTY

Full One Year Warranty

For one (1) year from the date of original retail purchase, any part which fails in normal home use will be repaired or replaced free of charge.

Limited Warranty

After the first year from date of original retail purchase, through the time periods listed below, the parts designated below which fail in normal home use will be repaired or replaced free of charge for the part itself, with the owner paying all other costs, including labor, mileage, transportation, trip charge and diagnostic charge if required.

Second Year – All parts.

Third through Fifth – The electronic console control board.

Note: This warranty does not include the motor control board, which is covered by the second year parts warranty only.

Third through Tenth – Drive motor, outer tub and sealed transmission.

Third through Lifetime – Stainless steel inner wash basket.

Additional Limited Warranty Against Rust-Through

Should an exterior cabinet, including the top and lid, rust through during the one year period starting from the date of retail purchase, repair or replacement will be made free of charge. After the first, and through the tenth year, repair or replacement will be made free of charge for the part itself, with the owner paying all other costs, including labor, mileage, transportation, trip charge and diagnostic charge if required.

Please Note: This full warranty and the limited warranty apply when the washer is located in the United States or Canada. Washers located elsewhere are covered by the limited warranty only, including parts which fail during the first two years.

The specific warranties expressed above are the ONLY warranties provided by the manufacturer. This warranty gives you specific legal rights, and you may also have other rights that vary from state to state.

To Receive Warranty Service

To locate an authorized service company in your area contact the Maytag dealer from whom your appliance was purchased; or call Maytag ServicesSM, Maytag Customer Assistance at the number listed below. Should you not receive satisfactory warranty service, please call or write:

Maytag ServicesSM
Attn: CAIR[®] Center
P.O. Box 2370
Cleveland, TN 37320-2370
U.S. or Canada (toll-free) 1-888-462-9824
U.S. customers using TTY for deaf, hearing impaired or speech impaired, call 1-800-688-2080.

When contacting Maytag ServicesSM, Maytag Customer Assistance about a service problem, please include the following:

- (a) Your name, address and telephone number;
- (b) Model number and serial number (found on the back of the control panel) of your appliance;
- (c) Name and address of your dealer and the date the appliance was purchased;
- (d) A clear description of the problem you are having;
- (e) Proof of purchase.

What is not covered by these warranties:

1. Conditions and damages resulting from any of the following:
 - a. Improper installation, delivery, or maintenance.
 - b. Any repair, modification, alteration or adjustment not authorized by the manufacturer or an authorized servicer.
 - c. Misuse, abuse, accidents, or unreasonable use.
 - d. Incorrect electric current, voltage or supply.
 - e. Improper setting of any control.
2. Warranties are void if the original serial numbers have been removed, altered, or cannot be readily determined.
3. Products purchased for commercial or industrial use.
4. The cost of service or service call to:
 - a. Correct installation errors.
 - b. Instruct the user on proper use of the product.
 - c. Transport the appliance to the servicer.
5. Consequential or incidental damages sustained by any person as a result of any breach of these warranties.
Some states do not allow the exclusion or limitation of consequential or incidental damages, so the above exclusion may not apply.

Use and Care Guide, service manuals and parts catalogs are available from Maytag ServicesSM, Maytag Customer Assistance.

Maytag • 403 West Fourth Street North • P. O. Box 39 • Newton, Iowa 50208