



# WASHING MACHINE

## Technical Information

- Due to possibility of personal injury or property damage, always contact an authorized technician for servicing or repair of this unit.
- Refer to Service Manual for detailed installation, operating, testing, troubleshooting, and disassembly instructions.

### CAUTION

All safety information must be followed as provided in Service Manual.

### WARNING

To avoid risk of electrical shock, personal injury or death; disconnect power to washer before servicing, unless testing requires power.

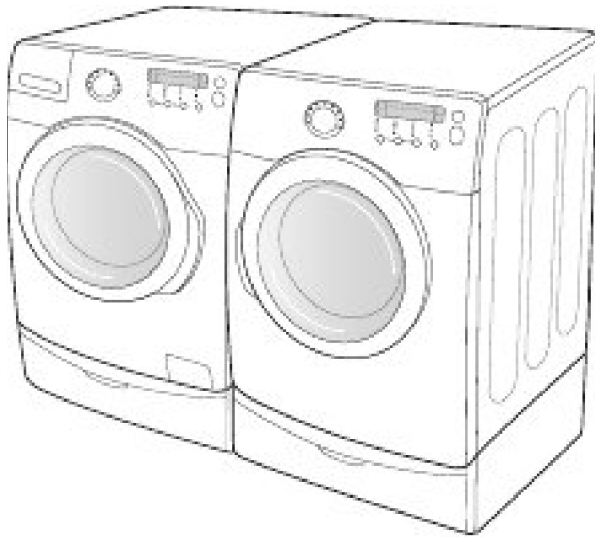

Code No. : DC68-02834A-02\_EN

# ALIGNMENT AND ADJUSTMENTS

## WARNING

To avoid risk of electrical shock, personal injury or death; disconnect power to washer before servicing, unless testing requires power.

### GENERAL ERROR FUNCTION

NO	Error Code	Diagnostic Code Error Image	Description	Corrective Action
1	nd	1	The water level fails to drop below the Reset Water Level within 15 minutes.	Go to "Will Not Drain" Troubleshooting Section.
2	LO	2	Door fails to Unlock After 7 attempts.	Go to "Will Not Unlock" Troubleshooting Section.
3	nF	3	When the filling Continues for more than 40 minutes or there is no change of water level for 6 minutes.	Go to "No Water Fill" Troubleshooting Section.
4	FL	4	Door fails to lock after 7 attempts.	Go to "Will Not Lock" Troubleshooting Section.
5	LE	8	A water level lower than the Reset water level (25.6Khz) is detected for 5 seconds during the Wash/Rinse cycle.	Go to "No Water Fill" Troubleshooting Section.
6	LE	8	Water Level Sensor Trouble. (When the input signal from the water level sensor is out of range, the unit will send out beeping sounds and halts the cycle.)	Go to "No Water Fill" Troubleshooting Section
7	OE	E	A fault is detected in the water level sensor. Data (frequency) shows the water level is at or above the overflow water level. (When this condition is detected, the machine will automatically starts draining water until the water level falls below the overflow water level)	First check to see that all of water valves are not stuck. If water valves are OK, check water level sensor.
8	dc	10	Unbalance or cabinet bump is detected during final spin, which prevents the drum from spinning over 150 rpm. (Never exceeds 150 RPM due to unbalanced load)	Go to "Wet Clothes" Troubleshooting Section.
9	E2	15	Jammed Key.(When key input signals are coming out for more than 30 seconds, it is regarded as a jam.)	Check all of keys. If A key is sensed to be pressed, all keys will do not respond.
10	dL	18	Door is detected as open when the motor is operating.	Check for loose wire connections. Go to "Quick Test Mode" and then do Door lock/Unlock Test and Motor Test.

## ALIGNMENT AND ADJUSTMENTS

**⚠ WARNING**

To avoid risk of electrical shock, personal injury or death; disconnect power to washer before servicing, unless testing requires power.

NO	error code	Diagnostic Code Error Image	Description	Corrective Action
11	ds	22	Door is detected as open while it is trying to lock the door.	Go to "Quick Test Mode" and then do Door Lock/Unlock Test
12	tE	29	Abnormal high/low temperature or resistance (Thermal sensor or PBA resistance).	Go to " Board Input Test" and check Water Temperature. Check loose or pinched wires. Replace PCB or thermistor.
13	3E	2E	MICOM is attempting to drive the motor but is not getting any response signals from the hall sensor. Visual check shows motor is not running. (Locked, Defective Hall Sensor or Overload)	Evaluate wire harness for loose or unhooked connections. Go to " Quick Test Mode" and test Motor.
14	Sr	34	System Relay (Main Relay) Failure. (PCB does not notice the relay operation when there should be.)	Replace PCB.
15	Hr	36	Heater Relay Failure (No Heater Relay Check Signal)	Replace PCB
16	nF1	5	The hot/cold water hose connection is not correct.	Please connect the hot/cold water hose connection correctly.
17	2E	-	Voltage for motor control bus is over or under specified limit.	Replace PCB
18	7E	-	Silver Care Kit (PCB) Failure.	Check PCB ,Main PCB & Wire-harness
19	suds	-	Suds is detected during the washing session. ("SUdS" is not an error. If the washer is in suds period, "SUdS" will light up instead of remaining time.)	Guide a user to reduce amount of detergent usage.
20	AE	-	Communication error between SUB PBA and MAIN PBA	Check Main PBA, SUB PBA & Wire-harness. Replace PCB
21	SF1, SF2, SF3	-	System Error	Replace PCB

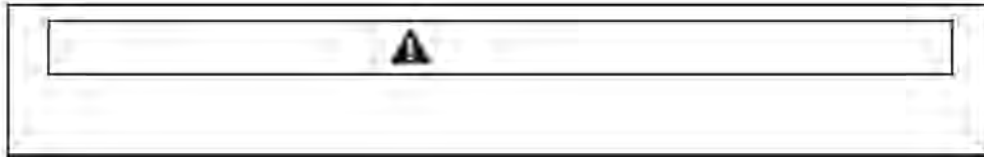

## TEST MODE

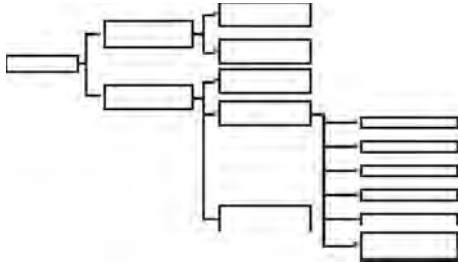

### Test Mode:

Each Test Mode for the Squall is as follows in the coming pages. The test modes indicated by the red arrows are modes unable to get an access once the washing cycle has started due to safety reasons.

## Quick Test Mode

### Definition of Quick Test Mode:

- Check operation of all LED's (Verify faulty LED).
- Check model and software version.
- Check different operating modes (e.g. water valve, motor, door, drain pump, etc.).

### How to Enter:

- Plug in the unit.
- Press Soil Level Key + Signal Key and Power Key at the same Time.

**Important.** Once test mode is performed, all data including the diagnostic code saved in the EEPROM will be erased.

# ALIGNMENT AND ADJUSTMENTS

## WARNING

To avoid risk of electrical shock, personal injury or death; disconnect power to washer before servicing, unless testing requires power.

### Quick Test Mode:

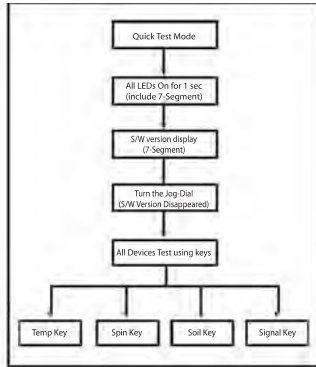

1. All LED's light up and it sends out Beep Sound when it enters into the Quick Test Mode. (Including 7-Segment)
2. Displays software version for a sec and Clear EEprom. (Ex. If S/W Version is 49, 7-Segment will display E149)
3. When the version is displayed, turn the Jog-Dial so that the version disappears. Press the following keys to test the various components.
  - Temp Key : Water Valve Test
  - Spin Key : Door Lock/Unlock Test
  - Soil Key : Water/Steam Heater Test(Steam Models)  
Water Test(Non-Steam Models)
  - Signal Key : Drain Pump Test

# ALIGNMENT AND ADJUSTMENTS

## WARNING

To avoid risk of electrical shock, personal injury or death; disconnect power to washer before servicing, unless testing requires power.

### EEPROM Clear Check

#### Definition of EEPROM Clear Mode:

- EEPROM initialization.
- All course/option settings are to be reset to default values after EEPROM initialization.
- When Service arises and it needs PCB replacement, EEPROM should be reset.

#### How to Enter:

- The unit needs to be on.
- Press Delay Start Key, Signal Key, and Power Key at the same time.

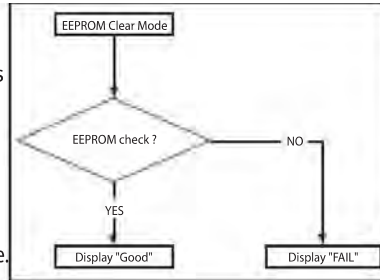

### Continuous Run Mode

#### Definition of Continuous Run Mode:

- Will continuously repeat the current cycle until the Continuous Run Mode is cancelled.

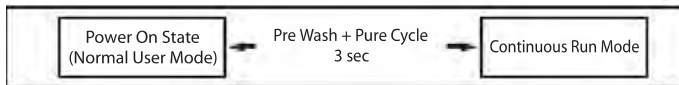

#### How to Enter:

- Press Pre Wash Key and Pure Cycle Key together for 3 sec.

#### Continuous Run Mode:

1. Press Pre Wash + Pure Cycle 3 sec during Power On State (Normal User Mode) .
2. Once in Continuous Run Mode, The seven segments will no longer display "0000" and will alternate between displaying the number of cycles of the completed course and the remaining time of the course.
3. The Continuous Run Mode will repeat the previous cycle until continuous run mode is cancelled.
4. During Continuous Run Mode, press Pre Wash + Pure Cycle 3 seconds to return to normal user mode. The seven segments will no longer display the number of cycles and will display the maintenance time only.
5. If you exit Service Mode after entering it from Continuous Mode, the washing machine returns to Continuous Mode.
6. If power is lost in Continuous Run Mode (that is, when the power plug is disconnected or the Power key is pressed turning the washing machine off), the mode is released when the washing machine is turned on again.

# ALIGNMENT AND ADJUSTMENTS

## WARNING

To avoid risk of electrical shock, personal injury or death; disconnect power to washer before servicing, unless testing requires power.

### Service Mode

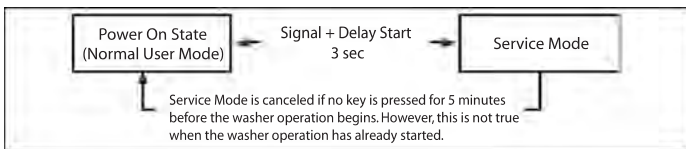

#### Definition of Service Mode:

- Service Mode enables service technicians to verify the operation of the washing machine and do troubleshooting.
- Service Mode can be entered during all washing cycle without interrupting the cycle except some of test modes.
- Various tests can be done with Service Mode. So, troubleshooting can be done based on the resulting diagnostic codes.

#### How to Enter:

- To enter the Service Mode, press the Signal and Delay Start Keys for 3 seconds or until the unit sends out beeping sounds.

#### Service Mode:

1. The washer must be on to go into the Service Mode.
2. The motor speed will be displayed when started (It displays 0 when the motor does not spin).
3. The present state of the machine will not be changed.  
(i.e., the current cycle in progress will not be interrupted and only the display will change)
4. To exit Service Mode, press Signal and Delay Start Keys for 3 second again, or Power Key. If no key is operated during Service Mode for 5 minutes, the machine will return to normal user mode.

# ALIGNMENT AND ADJUSTMENTS

## WARNING

To avoid risk of electrical shock, personal injury or death; disconnect power to washer before servicing, unless testing requires power.

### Quick Spin Test Mode

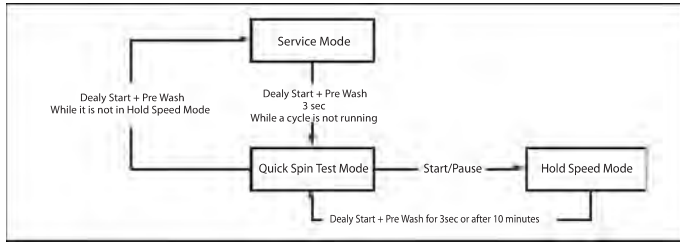

#### Definition of Quick Spin Test Mode:

- Quick Spin Test Mode is to do Spin Check. (High RPM)

#### How to Enter:

- During Service Mode, press the Dealy Start and Pre Wash Keys for 3 seconds to enter Quick Spin Test Mode. (Same for all Frontier 2 models.)
- Cannot enter once the washing cycle has started.

#### Quick Spin Test Mode:

As it enters into the Quick Spin Test Mode, it starts spinning and reaches to its maximum RPM.

Once the Spin speed reaches the maximum RPM, the speed drops immediately.

To hold Quick Spin Test Mode (entering Hold Speed Mode), press the Start/Pause button. If the Start/Pause button is pressed during Quick Spin Test Mode, it will stop accelerating and hold its spinning speed for 10 minutes before going back to Quick Spin Test Mode.

Also, to cancel the hold and allow Quick Spin Test Mode to continue, press the Dealy Start and Pre Wash Keys together for 3 seconds.

If you hold down the Dealy Start and Pre Wash keys for three (3) seconds when the washing machine is not in Hold Speed Mode, Quick Spin Mode is exited and Service Mode is restored.



# ALIGNMENT AND ADJUSTMENTS

## WARNING

To avoid risk of electrical shock, personal injury or death; disconnect power to washer before servicing, unless testing requires power.

### Cycle Count Check Mode

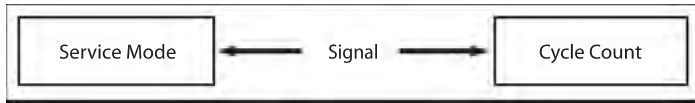

#### Definition of Cycle Count Check Mode:

- Cycle Count Check Mode is to tally up the number of washings.

#### How to Enter:

- To enter the Cycle Count Check Mode, press the Signal Key during Service Mode.

#### Cycle Count Check Mode:

1. Activate the Service Mode in advance.
2. When the Signal key is pressed, the total number of washings will light up and a signal LED will glow.
3. The maximum number of cycles will be 9999.  
The counter will roll over to 0 and start counting again after 9999.
4. The counting will be carried out at the end of the normal cycle.  
(For normal and Continuous Run cycles, the count is carried out at the end of the cycles.)
5. To exit the Cycle Count Check Mode, press the "Signal" key again.

### S/W Version Check Mode

#### Definition of S/W Version Check Mode:

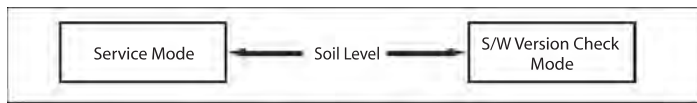

- S/W Version Check Mode is to bring up S/W Version information.

#### How to Enter:

- To enter the S/W Version Check Mode, press the Soil Level Key during Service Mode.

#### S/W Version Check Mode:

1. Activate the Service Mode in advance.
2. Press the Soil Level Key to bring up its software Version  
EX) Generate AE49 at Version 49 (AE is Micom code, 49 is it's software version)
3. To exit the S/W Version Check Mode, press the Soil Level S/W once again.  
Then, it returns to the Service Mode with motor RPM illuminating.

# ALIGNMENT AND ADJUSTMENTS

## WARNING

To avoid risk of electrical shock, personal injury or death; disconnect power to washer before servicing, unless testing requires power.

### Fast Time Down Test Mode

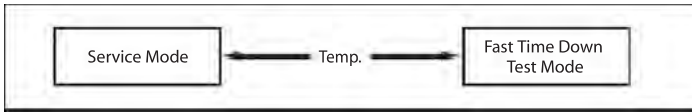

#### Definition of Fast Time Down Test Mode:

- Fast Time Down Test Mode is to forward the program to the next cycle stage.

#### How to Enter:

- To enter the Fast Time Down Test Mode, press the Temp key during Service Mode.

#### Fast Time Down Test Mode:

1. Activate the Service Mode in advance.
2. To forward the program to the next cycle stage, press the Temp key.

#### Each stage is located at key points of a complete cycle as follows:

- End of Each Fill (Beginning of Wash or Rinse Tumble Session)  
Caution: Check if the current water level is higher than the Reset water level and then perform the Fast time down test.
- Beginning of Drain Session
- Beginning of Spin Session (Here, it checks the water level. So, if it is over the reset level, it carries out draining before the spinning.)
- Beginning of Fill Session
- Beginning of Bleach Fill
- Beginning of Fabric Softener Fill
- Every 3 minutes during Wash and Rinse Tumble Session

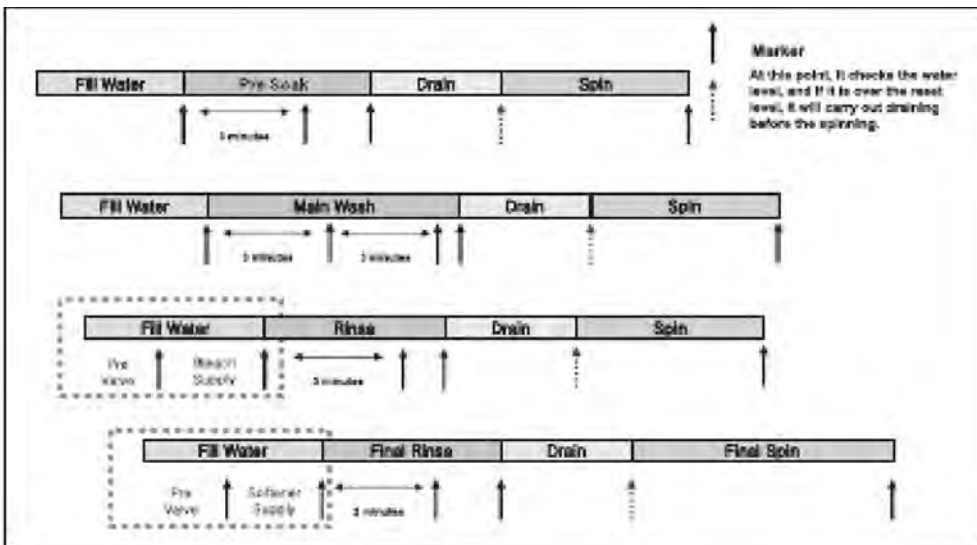

# ALIGNMENT AND ADJUSTMENTS

## WARNING

To avoid risk of electrical shock, personal injury or death; disconnect power to washer before servicing, unless testing requires power.

### Board Input Test Mode

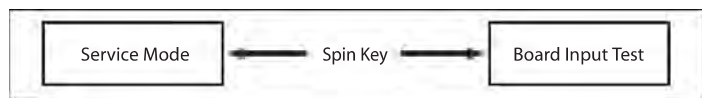

#### Definition of Board Input Test Mode:

- Board Input Test Mode is to displays a specified input after a key press.

#### How to Enter:

- To enter the Board Input Test Mode, press the Spin Key during Service Mode.

#### Board Input Test Mode:

1. Activate the Service Mode first.
2. Press the Spin Key to start Board Input Test.
3. Turn the Jog-Dial so that the Pre Wash LED is turned on, and press the Start/Pause key. The Water Temperature will be displayed in Celsius.
4. Turn the Jog-Dial so that the Extra Rinse(or Steam) LED is turned on, and press the Start/Pause key. The Water Temperature will be displayed in Fahrenheit.
5. Turn the Jog-Dial so that the Cold/Cold LED is turned on, and press the Start/Pause key. The door status will be displayed (OP if open, CL if closed).
6. Turn the Jog-Dial so that the No Spin LED is turned on, and press the Start/Pause key. The Door Lock Switch status will be displayed (UL if unlocked, LO if locked).
7. Turn the Jog-Dial so that the Soil Level Light LED is turned on, and press the Start/Pause key. The Water Frequency will be displayed.
8. Turn the Jog Dial so that the Signal Off LED is turned on and press the Start/Pause button. Within 3 seconds of pressing the button, the status of the Silver Nano kit is displayed.
  1. Delayed: **0000**
  2. Normal: ---
  3. Abnormal: **HE**

# ALIGNMENT AND ADJUSTMENTS

## WARNING

To avoid risk of electrical shock, personal injury or death; disconnect power to washer before servicing, unless testing requires power.

### Diagnostic Code Check Mode

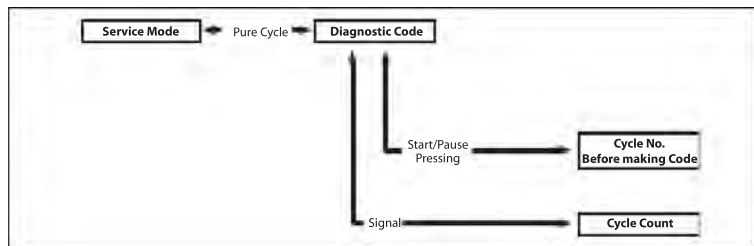

#### Definition of Diagnostic Code Check Mode:

- Diagnostic Code Check Mode is to bring up the stored diagnostic codes (reference codes for service technicians).

#### How to Enter:

- To enter the Diagnostic Code Check Mode with code "d" flashing, press the Pure Cycle key during Service Mode.

#### Board Input Test Mode:

1. Activate the Service Mode first.
2. Press the "Pure Cycle key" key to start Diagnostic Code Check Mode with Code "d" flashing.
3. To cycle through the diagnostic codes (d1,d2,d3~d9), turn the Rotary Cycle Selector in one direction (either Clockwise or Counterclockwise).
4. Now, when turning the Rotary Selector Key in the same direction, it shows diagnostic codes from the latest (d1).
5. When turning it in the opposite direction, it shows the diagnostic codes in the reverse order. Ex) When it stops at d5 and turns backward, it shows from d4 down to "d". Refer to Diagnostic Code.

# ALIGNMENT AND ADJUSTMENTS

## WARNING

To avoid risk of electrical shock, personal injury or death; disconnect power to washer before servicing, unless testing requires power.

### Demo Mode

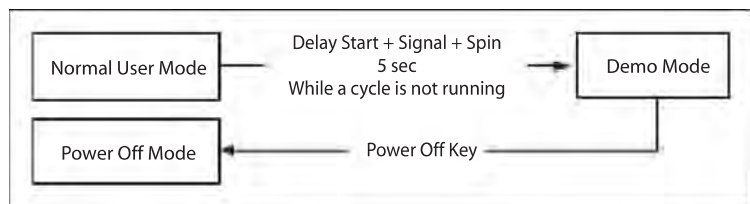

- Demo mode is entered when the Delay Start + Signal + Spin buttons are held down for five (5) seconds simultaneously in the power on state.
- When entering Demo mode, the buzzer rings three (3) times and “- - -” is displayed on the 7 segment display and all other LEDs are turned off. (Initial Demo mode)
- Demo mode consists of WASH, SPIN and LED modes.
- If the Temp button is pressed during the initial Demo mode, “WASH” blinks on the 7 segment display and the washing machine enters WASH mode.
- If the Start/Pause button is pressed in WASH mode, the door is locked (Door Lock) and the motor rotates left and right at 45 RPM in a 7 sec on and 3-sec off cycle.
- WASH mode continues up to five (5) minutes once started. After the five (5) minutes have elapsed, “- - -” is displayed on the 7 segment display and the initial Demo mode is maintained.
- If the Start/Pause button is pressed during a WASH mode operation, “- - -” is displayed on the 7 segment display and the initial Demo mode is maintained.
- If the Spin button is pressed in the initial Demo mode, “Spin” blinks on the 7 segment display and the washing machine enters SPIN mode.
- If the Start/Pause button is pressed in the SPIN mode, the door is locked (Door Lock) and a spin is operated at 1150 RPM. When the speed reaches 0 RPM, the No Spin, Low, Medium, High, and Extra High LEDs are turned on.
- During a spin operation, the No Spin LED turns on when the speed is lower than 400 RPM. The Low LED turns on between 400 RPM and 800 RPM. The Medium LED turns on between 800 RPM and 1000 RPM. The High LED turns on at higher than 1000 RPM.
- SPIN mode continues up to four (4) minutes once started. After the four (4) minutes have elapsed, “- - -” is displayed on the 7 segment display and the initial Demo mode is maintained.
- If the Start/Pause button is pressed during a SPIN mode operation, “- - -” is displayed on the 7 segment display and the initial Demo mode is maintained.
- If the Pure Cycle button is pressed during the initial Demo mode, “LED” is displayed on the 7 segment display and the washing machine enters LED mode.
- If the Start/Pause button is pressed in LED mode, all LEDs are turned on. The LED mode continues up to thirty (30) seconds once started. After the thirty (30) seconds have elapsed, “- - -” is displayed on the 7 segment display and the initial Demo mode is entered.
- If the Start/Pause button is pressed during an LED mode operation, “- - -” is displayed on the 7 segment display and the initial Demo mode is entered.

## TROUBLE SHOOTING

### WARNING

To avoid risk of electrical shock, personal injury or death; disconnect power to washer before servicing, unless testing requires power.

### TROUBLE DIAGNOSIS

- As the micom wash machine is configured of the complicate structure, there might be the service call.

Below information is prepared for exact trouble diagnosis and suitable repair guide.

#### Caution for the Repair and Replacement

Please follow below instruction for the trouble diagnosis and parts replacement.

- 1) As some electronic components are damaged by the charged static electricity from the resin part of machine or the human body, prepare the human body earth or remove the potential difference of the human body and machine by contacting the power supply plug when the work contacting to PCB is executed.

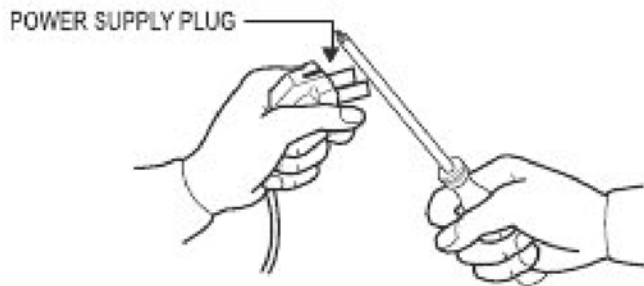

- 2) Since AC120V is applied to the triac T1 and T2 on P.C.B, the electric shock may occur by touching and be careful that the strong and weak electricity are mixed.
- 3) As the P.C.B assembly is designed for no trouble, do not replace the P.C.B assembly by the wrong diagnosis and follow the procedure of the trouble diagnosis when the micom is not operated normally.

# TROUBLE SHOOTING

## WARNING

To avoid risk of electrical shock, personal injury or death; disconnect power to washer before servicing, unless testing requires power.

### TROUBLE DIAGNOSIS

#### Will Not Start

- Plug the unit into the wall outlet. Check for proper voltage.
- Check fuse or reset circuit breaker.
- Push any key to turn on the washer and press the Start/Pause key to run the washer.
- Close door and push the Start/Pause key to run the washer.
- Check if washer is in a pause, soak or suds process. Wait briefly and it may start. (If the washer is in suds period, Suds will light up instead of remaining time.)
- Check for restricted drain system. (If there is electrical problem in drain system, "nd" error will occur after 15 minutes.)
- Check Water Supply.
- Check the line or water valve screen filter.
- Check if PCB connectors are assembled properly.
- Check if CN2 terminals on PCB are in good condition. (Refer to PCB Connector Check.)
- Replace PCB.

#### Leaking

- Make sure inlet hose connections are not leaking. Check for rubber gasket damage due to over tightening.
- Check standpipe for leak. Wrap a dry rag around the standpipe opening.  
If rag becomes wet, leak is fault of home plumbing.  
Be sure the standpipe is capable of accepting the flow of water from the washer.
- Make sure end of drain hose is correctly inserted and secured to drain standpipe.
- Check internal hose connections (fill, drain systems, dispenser hoses & clamps).
- Check rubber boot. Remove, reposition and reinstall, if necessary.
- Check for possible kinked dispenser to outer tub hose. Hot water pressurization may force door open.

#### No Tumble

- Start normal cycle with an empty machine and allow a fill to check tumble.
- Perform Quick Spin Test. (Before test, make sure that the tumbler is empty.)
- Check for loose connections at Machine Control Board, Pressure Switch, Motor, Tach Harness and Motor Control. (Refer to the component testing procedure)
- Check motor windings resistance.  
CN5 pins 1 & 3 = 11.6ohms  $\pm$ 7%,  
Pins 1 & 2 = 11.6ohms  $\pm$ 7%,  
Pins 2 & 3 = 11.6 ohms  $\pm$ 7%
- Faulty Main Control Board.
- Faulty motor.

#### Will Not Spin

- Make sure to close the door completely.
- Check for water left inside the washer. If so, go to "Will Not Drain".
- Perform Quick Test Mode or Quick Spin Test. Does the washer spin? (Before the test, empty the unit inside.)  
If it doesn't tumble after the above, change PCB. When the problem persists, change the motor.
- Perform Quick Test Mode or Quick Spin Test. Does the washer spin? If it does, Check Possible unbalanced load scenario in normal mode.
- Check for loose connections at PCB, Water Level Sensor, Motor, Hall Sensor Wire Harness. (CN7,CN5,CN6)  
(Refer to the Component Testing Procedure.)
- Check motor windings resistance. (CN5 Pin1&3 = 11.6 ohms (at  $\pm$ 7% 20°C/68°F),  
Pin1&2 = 11.6ohms (at  $\pm$ 7% 20°C),  
Pin2&3 = 11.6 ohms (at  $\pm$ 7% 20°C))

## TROUBLE SHOOTING

### WARNING

To avoid risk of electrical shock, personal injury or death; disconnect power to washer before servicing, unless testing requires power.

## TROUBLE DIAGNOSIS

### No Water Fill

- Perform Quick Test Mode. Check all of Water Valves visually.  
(Pre Wash Valve, Cold Water Valve, Bleach Water Valve, Softener dispenses using Cold & Bleach Water Valve, and Hot Water Valve.)
- Check if water taps are turned on fully.
- Check Water Valves and Water Level Sensor (Refer to PCB Connector Check)
- Check if there is any kink in inlet hoses.
- Check if inlet screens are clogged up.
- Check if water has enough pressure. If so, find out its contributors.
- Check if there is any frozen area in the unit (Drain Hose, etc)
- Measure the resistance of Water Valve Coil.  
(It should read 1.18K ohms. Check Pin#1 of CN2 and PIN#1,2,7,8,9 of CN3)
- Check Pressure S/W and PCB for loose connections. (Refer to PCB Connector Check.)

### Tub Full of Suds

- Go to "Will Not Drain" and "Will Not Spin" and check the draining.
- Check PCB and Drain Pump for any loose wire connection.
- Perform Quick Test Mode or Board Output Test to drain.
- Use HE (High-Efficiency) or low sudsing detergent specially formulated for front load washers.
- Reduce the amount of detergent for that specific load size and soil level. Keep in mind that towel creates more suds generally.
- Reduce the amount of detergent when water is soft, or laundry is small or lightly soiled.
- Do one more washing cycle with cold water and a table spoon of salt without detergent.



# TROUBLE SHOOTING

## WARNING

To avoid risk of electrical shock, personal injury or death; disconnect power to washer before servicing, unless testing requires power.

### TROUBLE DIAGNOSIS

#### Wet Clothes

- Unbalance due to not enough load. Put additional load.
- Due to excessive suds by using general detergent. Use HE (High-Efficiency) or reduce its quantity.
- Low Spin Speed or Drain Only was selected.
- Go to "Will Not Spin".

#### Will Not Lock

- Door is not aligned or closed properly.
- Perform Quick Test Mode. Check Door Lock.  
Check the output voltage of Door Lock Coil.  
If it reads 120V, change Door Lock Switch, and if not, change PCB. (Refer to PCB Connector Check.)
- Read Lock Switch and PCB (CN3). (Refer to PCB Connector Check.)
- Try Door Lock and check for 120V to Door Lock Connector. If 120V present, change Main Control Board and if not, change Door Lock switch.

#### Will Not Unlock

- Check if the door is being pushed out, which may keep it from unlocking.
- Door locks itself when the water level is too high. Opening door will result in water draining from door opening.
- Check the following with Board Input Test Mode.  
Water Level (frequency): Over 23.80 KHz.  
→ If so, refer to "Will Not Drain".  
Temperature (Inside Drum): Higher than 60°C/140°F.  
→ If so, wait until it drops.  
When everything is normal, check PCB connectors and Door Lock Switch.
- Drain manually after removing the plastic drain hose holder.
- Display shows "LO". Turn off and on the unit. If "LO" keeps illuminating, check PCB and Door Lock Switch.

# TROUBLE SHOOTING



## WARNING

To avoid risk of electrical shock, personal injury or death; disconnect power to washer before servicing, unless testing requires power.

### TROUBLE DIAGNOSIS

- Read Lock Switch and PCB (CN2 & CN3). (Refer to PCB Connector Check.)
- Perform Quick Test Mode. Check Door Lock. Check the output voltage of Door Lock Coil. If it reads 120V, change Door Lock Switch, and if not, change PCB. (Refer to PCB Connector Check.)

#### No Key Operation

- Option and Function buttons respond differently according to each cycle.
- Child Lock is being activated. To exit, hold down Soil Level Key and Signal Key simultaneously until it sends out a beeping sound.
- When "End" illuminates on the display, only Power button works. Press Power button and make new cycle selections.

#### Will Not Drain

- Check for any kink on the drain hose. If any, straight it out.
- Check for any restriction in the drain hose.
- Close the door and press the Start/Pause Button. For safety reasons, the washer does not tumble or spin with the door open.
- When it is freezing outside, check if it is frozen inside the drain hose.
- Check if the water level signal input is correct. Go to Board Input Test Mode.
- Go to Quick Test Mode and do Drain Pump Test.
- Check if there is any twist in the hose (the one between Tub and Drain Pump).
- Check if it reads AC 120V at the pump when a spin cycle is selected.
- Read the winding resistance of the pump motor. ( $14.2 \pm 7\%$  Ohms)
- Check the pump at CN3(PIN3) on PCB. It should read AC 110~120V. (Refer to PCB Connector Check)

# TROUBLE SHOOTING

## WARNING

To avoid risk of electrical shock, personal injury or death; disconnect power to washer before servicing, unless testing requires power.

### TROUBLE DIAGNOSIS

#### Wrong Water Temperature

- Check if both of the water taps are fully open.
- Make sure the domestic water heater is set to deliver water lower than 120°F (49°C) hot water at the tap. Also check water heater capacity and recovery rate.
- If the water heater is located far from the washer, screw out the hot water tap and let its water pass until you get hot water.
- Too Hot/Too Cold: Reduced amount of water is supplied while PCB controls the influx to regulate the actual temperature of the water in the tub. This may appear to be significantly hotter/colder than expected.
- Check if the temperature selection is correct.
- Disconnect inlet hoses from the Water Valve and remove any residue in the inlet screens.

#### Noisy and/or Vibration/Walking

- Check if the washer is leveled and the lock nuts are tightened up on the bottom plate.
- Check if all of the shipping bolts and spacers are removed from the back panel.
- Check if load is big enough and there is no unbalance. If there is not enough load, put in a few towels to balance it.
- Check if the motor is fastened enough.
- Remove various trouble contributors (such as dust coat on the floor).

#### Rubber Feet Leaving Marks on Floor

- Use a pencil eraser to remove mark.
- Walk washer into location, do not drag.

#### Additive Cups Full of Water

- Small amount of water in bottom of additive cups is normal.
- Remove and wash Dispenser Tray, removable Cup, and Rinse Cap.
- Level washer.

#### Buttons do not Respond

- Option and Function buttons respond differently according to each cycle.
- Child Lock feature has been selected. To disable feature press and hold Temp and Spin simultaneously until a beep is heard.
- When display shows "End", only the Power button will function. Press Power and make new cycle selections.

# TROUBLE SHOOTING

## WARNING

To avoid risk of electrical shock, personal injury or death; disconnect power to washer before servicing, unless testing requires power.

### PROBLEM CHECKING AND METHOD OF PCB

- If you plug in the power cord and turn Power S/W on, memorized data is displayed.  
If any data is not displayed, check the followings.



#### **Thermistor Check**

Check Voltage at Pin #4 and #5 of CN7

Tester Check = DC 2.5V

If it reads 5V, Check if its connector is engaged properly

#### **Door Switch Check**

Check Voltage at Pin #1 and #3 of CN4

When Door Open = DC 25V

When Door Close = DC 0V

#### **Water Sensor Check**

Check Voltage and Frequency at Pin #5 and #6 of CN7

Reset water level = DC2.5V, 25.8KHz

Check Voltage and Frequency at Pin #5 and #7 of CN7

Reset water level = DC2.5V, 25.8KHz

#### **Hall Sensor Check**

Check Voltage at Pin #4 and #2 of CN6

Tester Check = DC 0V or 3.75V

Check Voltage at Pin #4 and #3 of CN6

Tester Check = DC 0V or 3.75V

#### **Motor Check**

Resistance at Pin #1 and #2 of CN5 = 12Ω

Resistance at Pin #1 and #3 of CN5 = 12Ω

Resistance at Pin #2 and #3 of CN5 = 12Ω

#### **Door Lock Check**

Check Voltage at Pin #3 of CN2 and Pin #1 of CN3

When Door Lock = AC 120V

#### **Door Unlock Check**

Check Voltage at Pin #3 of CN2 and Pin #2 of CN3

When Door Unlock = AC 120V

#### **Drain Motor Check**

Check Voltage at Pin #3 of CN2 and Pin #3 of CN3

When Drain Motor operates = AC 120V

#### **Water Valve Check**

Check Voltage at Pin #3 of CN2 and Pin #1,2,7,8,9 of CN3

When each valve operates = AC 120V

#### **AC Power Check**

Check Voltage at Pin #1 and #2 of CN2

Tester Check = AC 120V

#### **Wash Heater Relay Check**

Check Voltage at Pin #3 of CN2 and PIN #2 of RY3

When Heater Relay operates = AC 120V

Steam Heater Relay Check(Only Steam Models)

Check Voltage at Pin #3 of CN2 and PIN #2 of RY4

When Heater Relay operates = AC 120V

# WIRING DIAGRAM

## WARNING

To avoid risk of electrical shock, personal injury or death; disconnect power to washer before servicing, unless testing requires power.

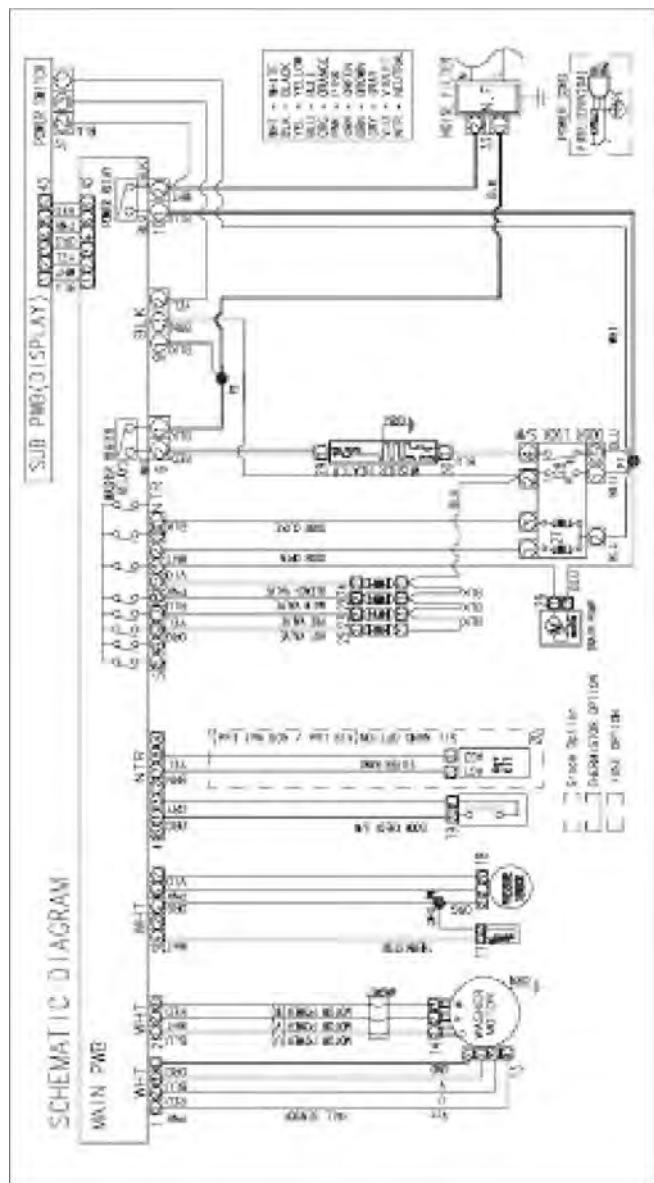

# WATER FLOW DIAGRAM

**⚠ WARNING**

To avoid risk of electrical shock, personal injury or death; disconnect power to washer before servicing, unless testing requires power.

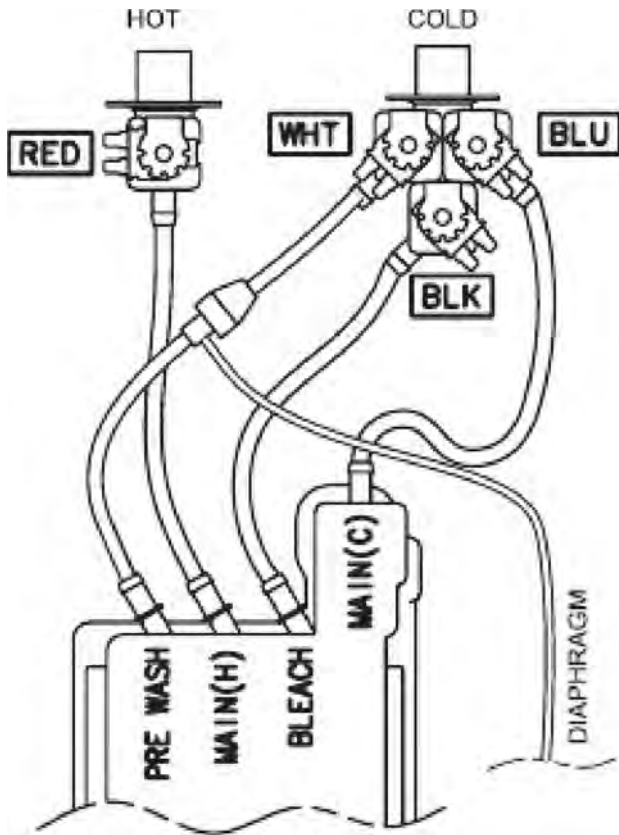

# MEMO

