

## 2. FEATURES & TECHNICAL EXPLANATION

---

### 2-1.FEATURES



#### ■ **Jumbo drum**

LG's jumbo drum can wash about 40% more per load than conventional washing machine. A bigger drum improves the wash performance.

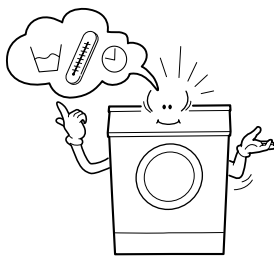

#### ■ **More economical by Fuzzy Logic System**

FUZZY Logic System detects the amount of load and water temperature, and then determines the optimum water level and washing time to minimize energy and water consumption.

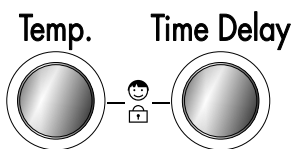

#### ■ **Child-Lock**

The Child-Lock system has been developed to prevent children from pressing any button to change the programme during operation.

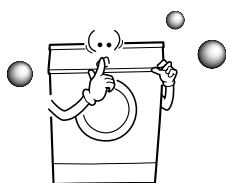

#### ■ **Low noise speed control system**

By sensing the amount of load and balance, evenly distributes load to minimize the spinning noise level.

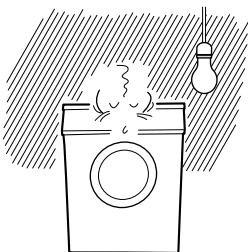

#### ■ **Auto Restart**

Although the washing machine is turned off by a power failure, it restarts automatically in its stopped process when power is supplied again. and it will be the same when the machine unplugged in operation is plugged in again.

---

## 2-2.DETERMINE WASHING TIME BY FUZZY LOGIC

To get the best washing performance optimal time is determined by sensing of water temperature, selected washing temperature and laundry amount.

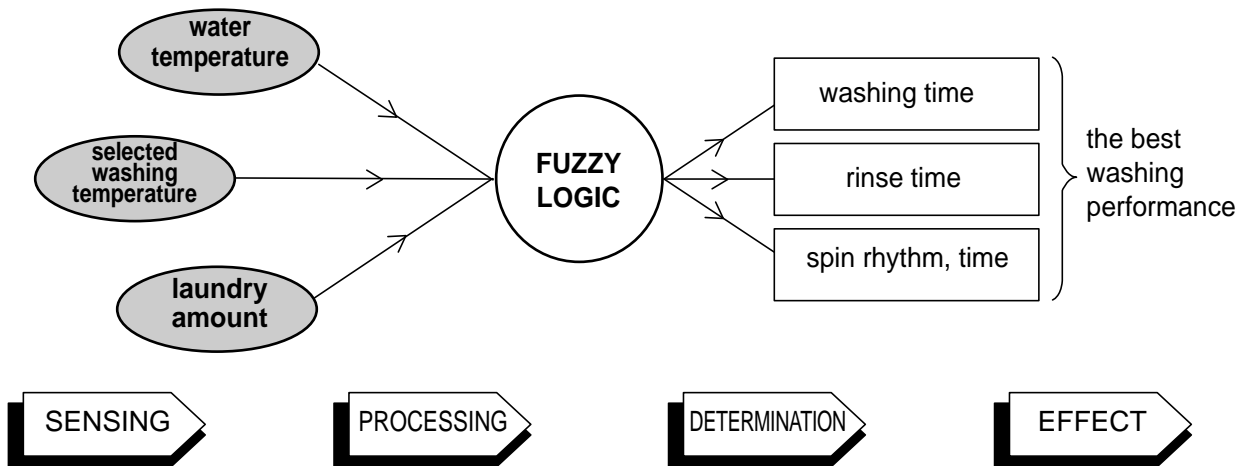

## 2-3.WATER LEVEL CONTROL

- This model adopts a pressure sensor which can sense the water level in the tub.
- When the water level reaches to the preset level water supply is stopped, then washing program proceeds.
- Spinning does not proceed until the water in the tub reduces to a certain level.

## 2-4.THE DOOR CAN NOT BE OPENED

- While program is operating.
- While Door Lock light turns on.

# 4. INSTALLATION

- ① Before servicing ask troubles of customers
- ② Check the adjustment(power supply is 220-240V, remove the transit bolts....)
- ③ Check the troubles referring to the trouble shooting.
- ④ Decide service steps referring to disassembly instructions.
- ⑤ And then, service and repair.
- ⑥ After servicing, operate the appliance whether it works O·K or NOT.

## ■ STANDARD INSTALLATION

The appliance should be installed as follows.

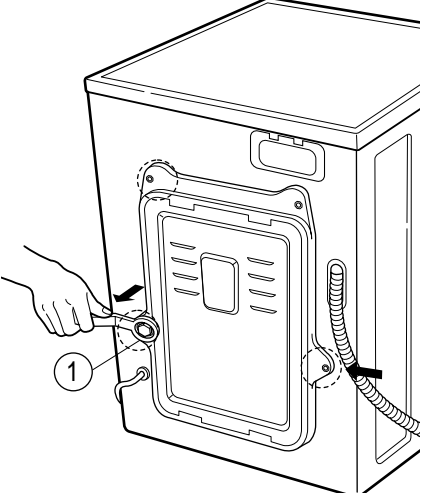
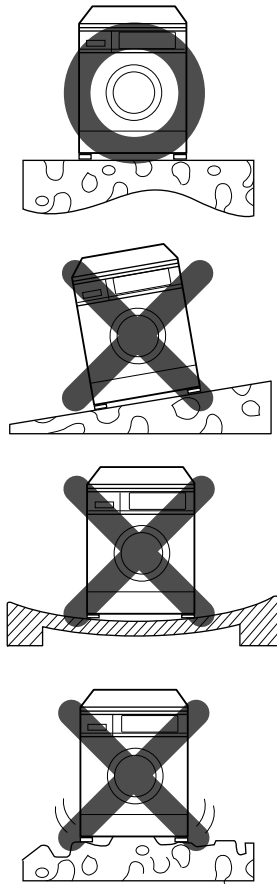
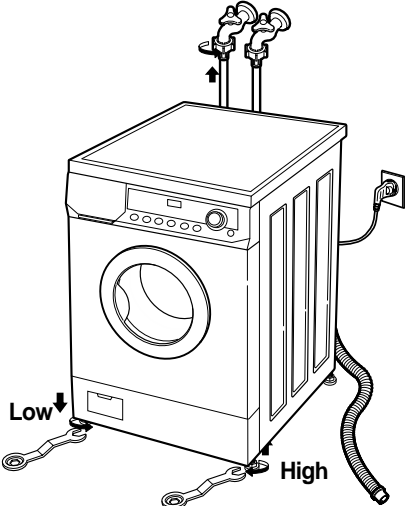
REMOVE THE TRANSIT BOLTS	INSTALL THE APPLIANCE ON FLAT AND FIRM SURFACE	ADJUST THE HORIZONTAL
<ul style="list-style-type: none"> <li>• Remove the transit bolts (4EA: ①) with supplied spanner.</li> <li>• Keep the transit bolts and spanner for future use.</li> <li>• Insert the 4 caps provided into the hole.</li> </ul> 		<ul style="list-style-type: none"> <li>• Turn the leveling feet to set the appliance horizontally.</li> </ul>  <ul style="list-style-type: none"> <li>• The appliance goes up by rotating the feet clockwise.</li> <li>• The appliance come down by rotating the feet counter clockwise.</li> </ul>

## ■ HOW TO CONNECT INLET HOSE

- Check that the rubber packing is inside of the valve connector.
- Connect the inlet hose firmly to prevent leak.

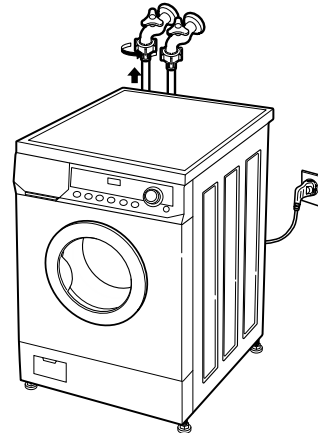

## ■ CONNECT DRAIN HOSE

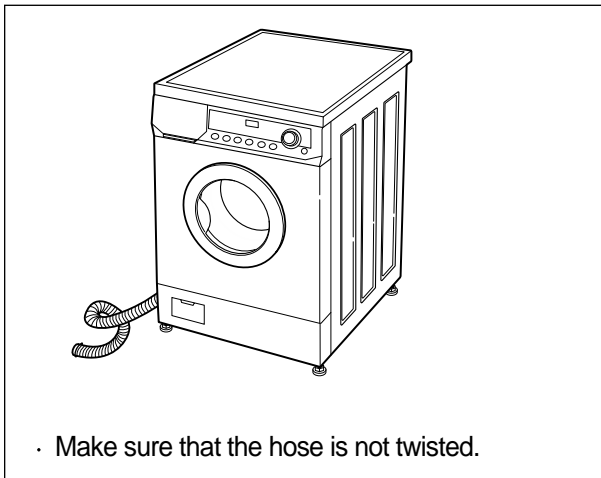

※ The drain hose should be placed under 100cm from the floor.

## ■ CONNECT POWER PLUG

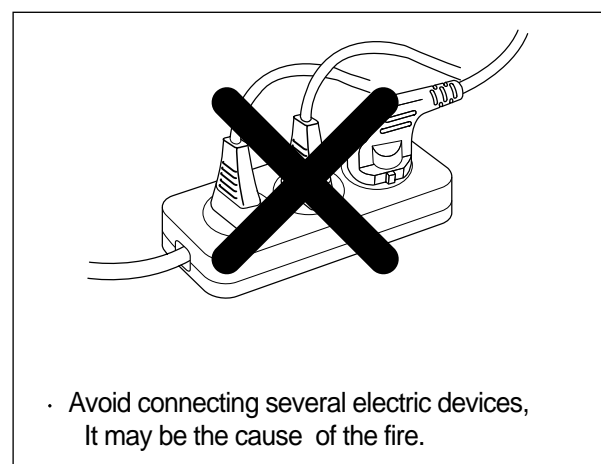
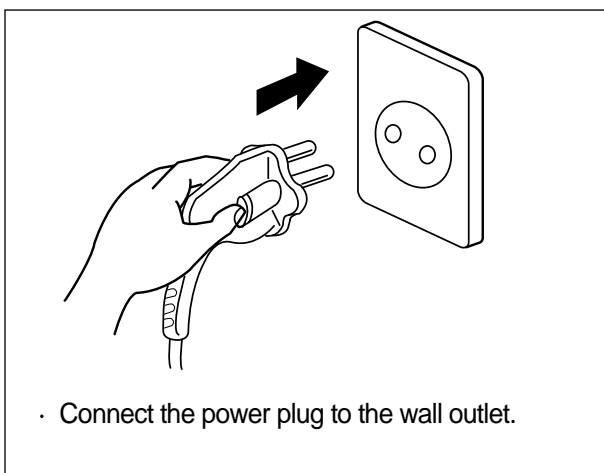

## 7 TEST OPERATION

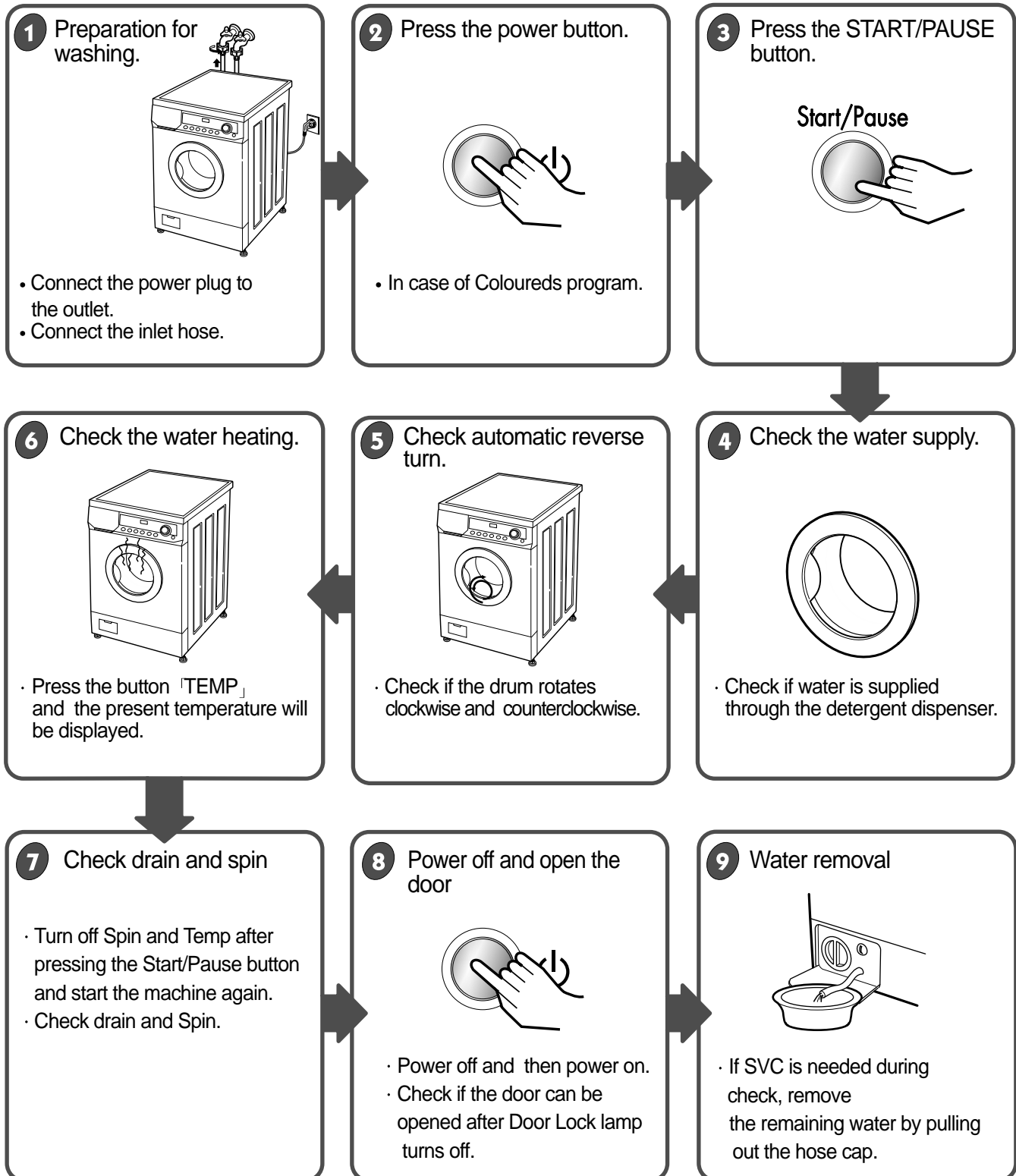

# 6. WIRING DIAGRAM

■ WD(M)-8070F(H)B, WD(M)-1070(5)F(H)B, WD(M)-1170(5)F(H)B, WD(M)-1270(5)F(H)B, WD(M)-1370(5)F(H)B

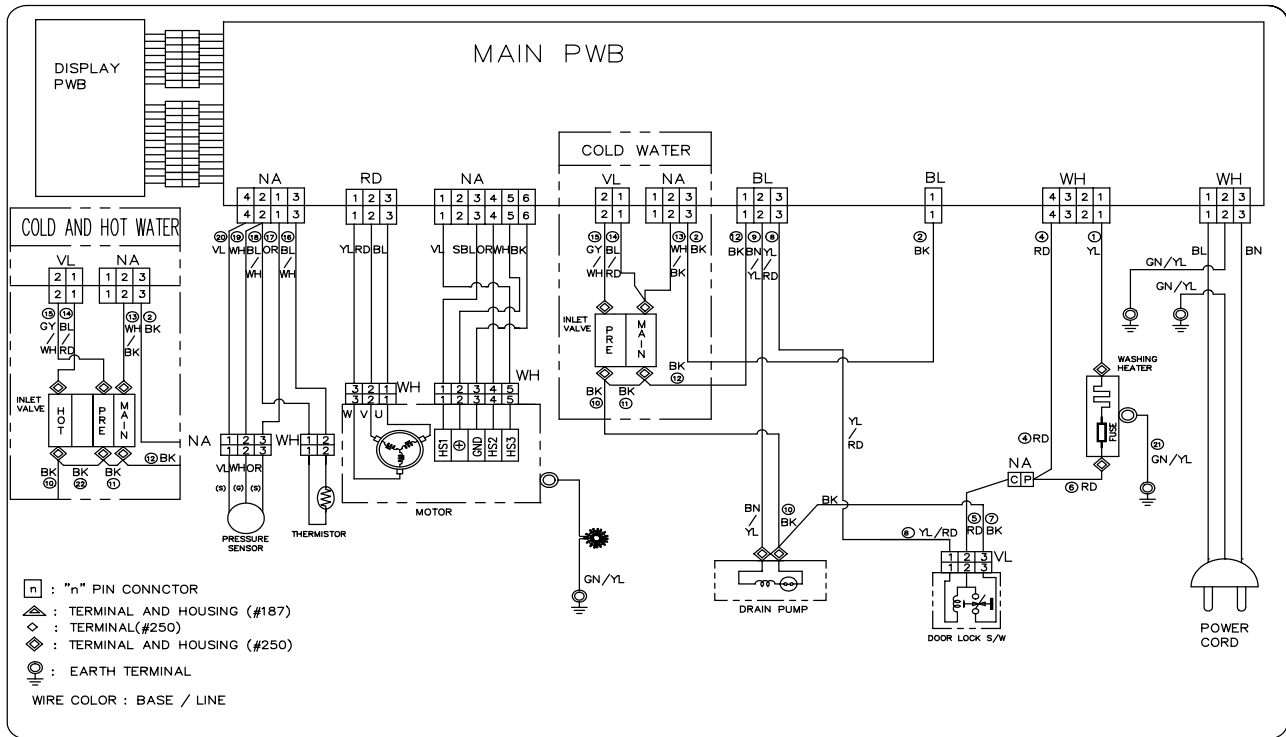

■ WD-8070F(H), WD-1070(5)F(H)

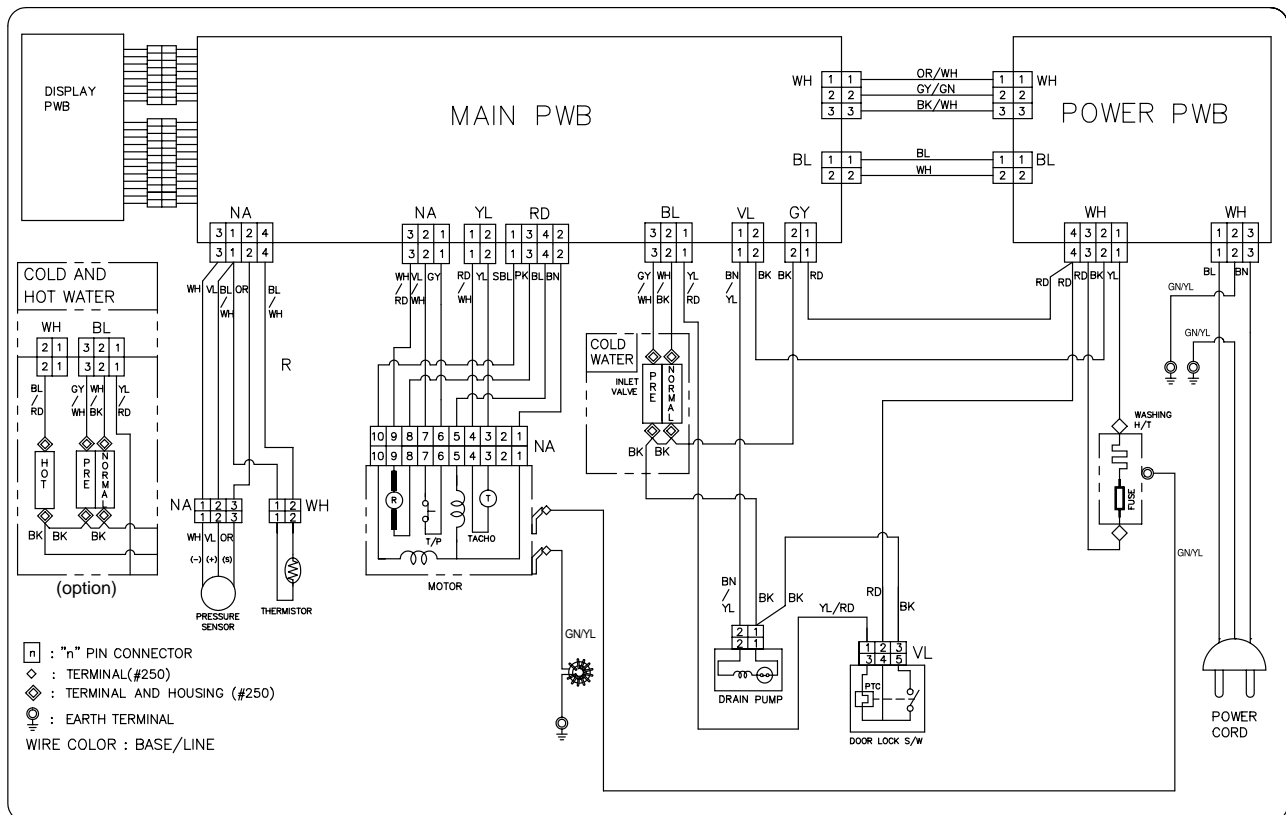

# 7. PROGRAM CHART

C Y C L E P R O G R A M T E M P E R A T U R E (°C)		Washing										Rinse										Spin		A U T O D R Y P R O G R A M		Normal Working Time (Hour:Minute)						
		Pre					Main					Normal					Rinse +					Spin	D-T	N	D							
		W	W	W	W	W	W	W	W	W	W	1	2	3	4	5	6	7	8	9	10						1	2	3	4	5	6
		W	W	W	W	W	W	W	W	W	W	W	W	W	W	W	W	W	W	W	W	W	W	W	W		W	W	W	W	W	W
120	60	65	240	120	60	60	60	60	60	60	60	60	60	60	60	60	60	60	60	60	60	60	60	60	60	60	60	60	60			
Whites	[Bar chart showing active periods for Whites program]																				About 2:30											
Coloureds	[Bar chart showing active periods for Coloureds program]																				About 1:55											
Synthetic	[Bar chart showing active periods for Synthetic program]																				About 1:28											
Delicate	[Bar chart showing active periods for Delicate program]																				About 58											
Wool	[Bar chart showing active periods for Wool program]																				About 58											
Handwash	[Bar chart showing active periods for Handwash program]																				About 57											
Rinse + Spin	[Bar chart showing active periods for Rinse + Spin program]																				About 19											
Spin	[Bar chart showing active periods for Spin program]																				About 11											
Pump	[Bar chart showing active periods for Pump program]																				About 1											

- \* Pre Wash : If the laundry is heavily soiled, "Pre Wash" course is effective. Pre Wash is available in Coloureds, Whites and Synthetic Program.
- \* Eco : By selecting Eco function, the water temperature is reduced and washing time is lengthened. So you can economize in your consumption of energy.
- \* Rinse+ : If you wish to rinse more, the Rinse+ function will remove any trace of detergents.
- \* Bio : If you want to eliminate protein stains (milk, blood, chocolate...), you may select Bio function by pressing the option button.
- \* You can select Bio function and Eco function when temperature is higher than 60°C in Whites, Coloureds and Synthetic.

# 8. TROUBLE SHOOTING

## 8-1. BEFORE SVC CHECKING

- ⌚ Be careful of electric shock or disconnecting the parts while trouble shooting.
- ⌚ Voltage of each terminal in 220-240V~ and DC while applying an electric current.

## 8-2. QC TEST MODE.

- ⌘ Pressing Spin, and Temp button simultaneously.
- ⌘ Power supply ON with pressing upper two button. then buzzer sound twice.
- ⌘ Press the START/PAUSE button as follows.
- ⌚ Press the START/PAUSE button more 4 times until stop spinning ;

Pressing number of START/PAUSE button	Checking Point	Display Status
None	All lamps turn on	
1 time	Clockwise spin(right)	Motor rpm(About 45)
2 times	Low speed Spin	Motor rpm(About 63~67)
3 times	High speed Spin	Motor rpm(About 79~85) : WD(M)-8070F(H)(B)
		Motor rpm(About 100~106) : WD(M)-1070(5)F(H)(B)
		Motor rpm(About 107~103) : WD(M)-1170(5)F(H)(B)
		Motor rpm(About 114~120) : WD(M)-1270(5)F(H)(B)
		Motor rpm(About 122~127) : WD(M)-1370(5)F(H)(B)
4 times	Inlet valve for pre-wash operation	Water level frequency(25~65)
5 times	Inlet valve for main-wash operation	Water level frequency(25~65)
	Hot inlet valve in case of hot water fill	
6 times	Inlet valve for main-wash operation	Water level frequency(25~65)
7 times	Counterclockwise spin(left)	Motor rpm(About 45)
8 times	A Heater is in operation for 3 sec.	Water Temperature
9 times	Draining pump operation	Water level frequency
10 times	Auto off operation	

## 8-3. HOW TO KNOW THE WATER LEVEL FREQUENCY

Press the Option and Spin button simultaneously.

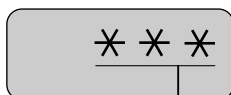







• The digits means water level frequency( $10^{-1}$  )



ex) 241 : Water level frequency =  $241 \times 10^{-1}$   
 $= 24.1$

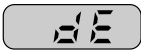

## 8-4. ERROR DISPLAY.







- If you press the [Start/Pause] button in error condition, any error except 'FE' will disappear and the machine will change into pause status.
- In case of 'PE', 'LE', 'dE', if the error is not resolved within 20 sec., and in case of other errors, if the error is not resolved within 4 min., power will be turned off automatically and the error only will be blinked. But in case of 'FE', power will not be turned off.

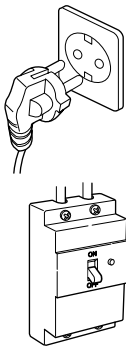

	ERROR	SYMPTOM	CAUSE
1	WATER INLET ERROR		§ Water has not reached to the pre-set level within 4 min. since inlet valve operated or water has not reached to the normal level within 25 min.
2	IMBALANCE ERROR		§ The appliance is tilted. § Laundry is gathered to one side. § Non distributable things are put into the drum.
3	DRAIN ERROR		§ Water has not drained enough within 5 min.
4	OVER FLOW ERROR		§ Water is automatically being pumped out because too much water is in the tub.
5	SENSOR PRESSURE S/W ERROR		§ The sensor pressure switch is out of order.
6	DOOR OPEN ERROR		§ The [Start/Pause] button is pressed with the door open. § The door switch is out of order.
7	HEATING ERROR		§ The thermistor is out of order.
8	SENSOR ERROR		§ The connector (5pin, male, white) in the Wire Harness is not connected to the connector (5 pin, female) of Hall Sensor in the MOTOR. f_ ' reconnect or repair the contact in the connector

	<b>ERROR</b>	<b>SYMPTOM</b>	<b>CAUSE</b>
<b>8</b>	SENSOR ERROR		<ul style="list-style-type: none"> <li>• The electric contact between the connectors (5 pin, male in the Wire Harness and 5 pin female in the Hall Sensor) is bad or unstable. <i>f_</i> Reconnect or repair the contact in the connector</li> <li>• The connector (6 pin, male, natural) in the Wire Harness is not connected to the connector (6 pin, female, natural) of PWB ASSY(Main) or the electric contact of connectors is bad/unstable. <i>f_</i> Reconnect or repair the contact in the connector</li> <li>• The electric contact between the connectors; 6 pin, male in the Wire Harness and 6 pin female in the controller(Main) is bad or unstable. <i>f_</i> Reconnect or repair the contact in the connector</li> <li>• The Wire Harness between Hall Sensor in the MOTOR and PWB ASSY(Main) is cut(open circuited). <i>f_</i> Repair/replace the damaged WIRE HARNESS</li> <li>• The Hall Sensor is out of order/defective. <i>f_</i> Replace the Motor</li> <li>• The controller(Main) is out of order/defective. <i>f_</i> Replace the PWB ASSY(Main)</li> </ul>
<b>9</b>	CURRENT ERROR		<ul style="list-style-type: none"> <li>• PWB ASSY(Main) is out of order <i>f_</i> Replace the PWB ASSY(Main)</li> <li>• Winding in the MOTOR is short-circuited. <i>f_</i> Replace the MOTOR</li> </ul>
<b>10</b>	LOCK ERROR		<ul style="list-style-type: none"> <li>• The Connector(3 pin, male, white) in the Wire Harness is not connected to the Connector(3 pin, female, white) of MOTOR. <i>f_</i> Reconnect or repair the connector</li> <li>• The electric contact between the connectors; 3 pin, male, white in the Wire Harness and 6 pin, female, white in the PWB ASSY(Main) is bad or unstable. <i>f_</i> Reconnect or repair the contact in the connector</li> <li>• The Wire Harness between the MOTOR and PWB ASSY(Main) is cut(open circuited). <i>f_</i> Repair the damaged(open-circuited) WIRE HARNESS</li> <li>• The hall sensor is out of order/defective. <i>f_</i> Replace the PWB ASSY(Main)</li> </ul>

# 9. ERROR DIAGNOSIS AND CHECK LIST

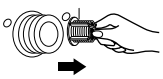
## 9-1. DIAGNOSIS AND ANSWER FOR ABNORMAL OPERATION

SYMPTOM	GUIDE FOR SERVICE CALL	
<p>NO POWER</p>	<p>Is the power plug connected firmly to 220-240V~ outlet?</p> <p style="text-align: center;"><b>YES</b></p> <p>Power failure? or Breaker opened?</p> <p style="text-align: center;"><b>NO</b></p> <p style="text-align: center;">Visit to check</p>	
<p>Water inlet trouble</p> 	<p>Is "no inlet" displayed?</p> <p style="text-align: center;"><b>YES</b></p> <p>Is the tap opened?</p> <p style="text-align: center;"><b>YES</b></p> <p>Is the tap frozen?</p> <p style="text-align: center;"><b>NO</b></p> <p>Is the water supply shut-off?</p> <p style="text-align: center;"><b>NO</b></p> <p>Is filter in the inlet valve clogged with foreign material?</p> <p style="text-align: center;"><b>NO</b></p> <p style="text-align: center;">Visit to check</p>	    <div style="border: 1px solid black; padding: 5px; margin-top: 10px;"> <p style="text-align: center;"><b>YES</b></p> <p style="text-align: center;">Clean the filter of inlet valve</p>  </div>

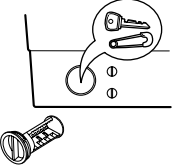
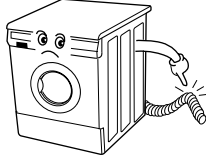
SYMPTOM	GUIDE FOR SERVICE CALL
<p>◦ DOOR OPEN ERROR</p> <p>Refer to 7-4 ERROR DISPLAY</p>	<div data-bbox="544 421 1377 817"> <p>Did you press the 「Start/Pause」 button when the door is open?</p> <p><b>YES</b> → Close the door</p>  <p><b>NO</b> ↓</p> <p>Visit to check</p> <p><b>&lt; Check if the door switch is O.K &gt;</b></p> </div>
<p>◦ Drain Trouble</p> 	<div data-bbox="544 929 1446 1444"> <p>Is "no drain" displayed?</p>  <p><b>YES</b> ↓</p> <p>Is the debris filter clogged with foreign material such as pin, coin and etc.?</p> <p><b>YES</b> → Clean up the filter.</p>  <p><b>NO</b> ↓</p> <p>Is the drain hose frozen with water, kinked or crushed?</p> <p><b>NO</b> ↓</p> <p>Visit to check</p>  </div>

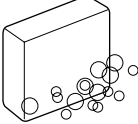
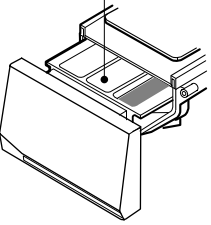
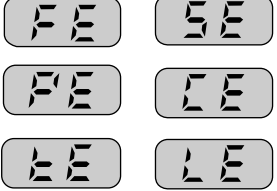
SYMPTOM	GUIDE FOR SERVICE CALL
<p>◦ Suds overflow from the appliance. (In this condition, wash and spin do not operate normally)</p>	<div style="display: flex; justify-content: space-between;"> <div style="width: 65%;"> <p>Is Low-sudsing detergent for the drum washing machine used?</p> <p style="text-align: center;"><b>YES</b></p> <p>Is the proper amount of detergent used as recommended?</p> <p style="text-align: center;"><b>YES</b></p> <p>Recommend to reduce the using amount of detergent.</p> <ul style="list-style-type: none"> <li>* This appliance has the automatic suds sensing function which operates under much suds condition for good rinse and preventing overflow.</li> <li>* When much suds are sensed, suds removing function such as drain, water input and pause will operate without rotating the drum.</li> </ul> </div> <div style="width: 30%; text-align: center;">  <p><b>LOW LATHERING DETERGENT</b></p> </div> </div>
<p>◦ No effect of softener</p>	<div style="display: flex; justify-content: space-between;"> <div style="width: 65%;"> <p>Is softener put in the correct compartment of drawer?</p> <p style="text-align: center;"><b>YES</b></p> <p>Is the drawer closed during wash?</p> <p style="text-align: center;"><b>YES</b></p> <p>Is the softener cap clogged?</p> <p style="text-align: center;"><b>YES</b></p> <p>Explain how to use softener</p> <p><b>&lt; Clean the compartment for softener &gt;</b></p> </div> <div style="width: 30%; text-align: center;"> <p>Compartment for softener</p>  </div> </div>
	<p style="text-align: center;">Visit to check</p>

## 9-2. FAULT DIAGNOSIS AND TROUBLE SHOOTING

■ WD(M)-8070F(H)B, WD(M)-1070(5)F(H)B, WD(M)-1170(5)F(H)B, WD(M)-1270(5)F(H)B, WD(M)-1370(5)F(H)B

### CAUTION

1. Be careful of electric shock or disconnecting the parts while trouble shooting.
2. First of all, check the connection of each part terminal with wiring diagram.
3. If you replace the PWB assy(Main), Put in the connectors correctly.

### NO POWER

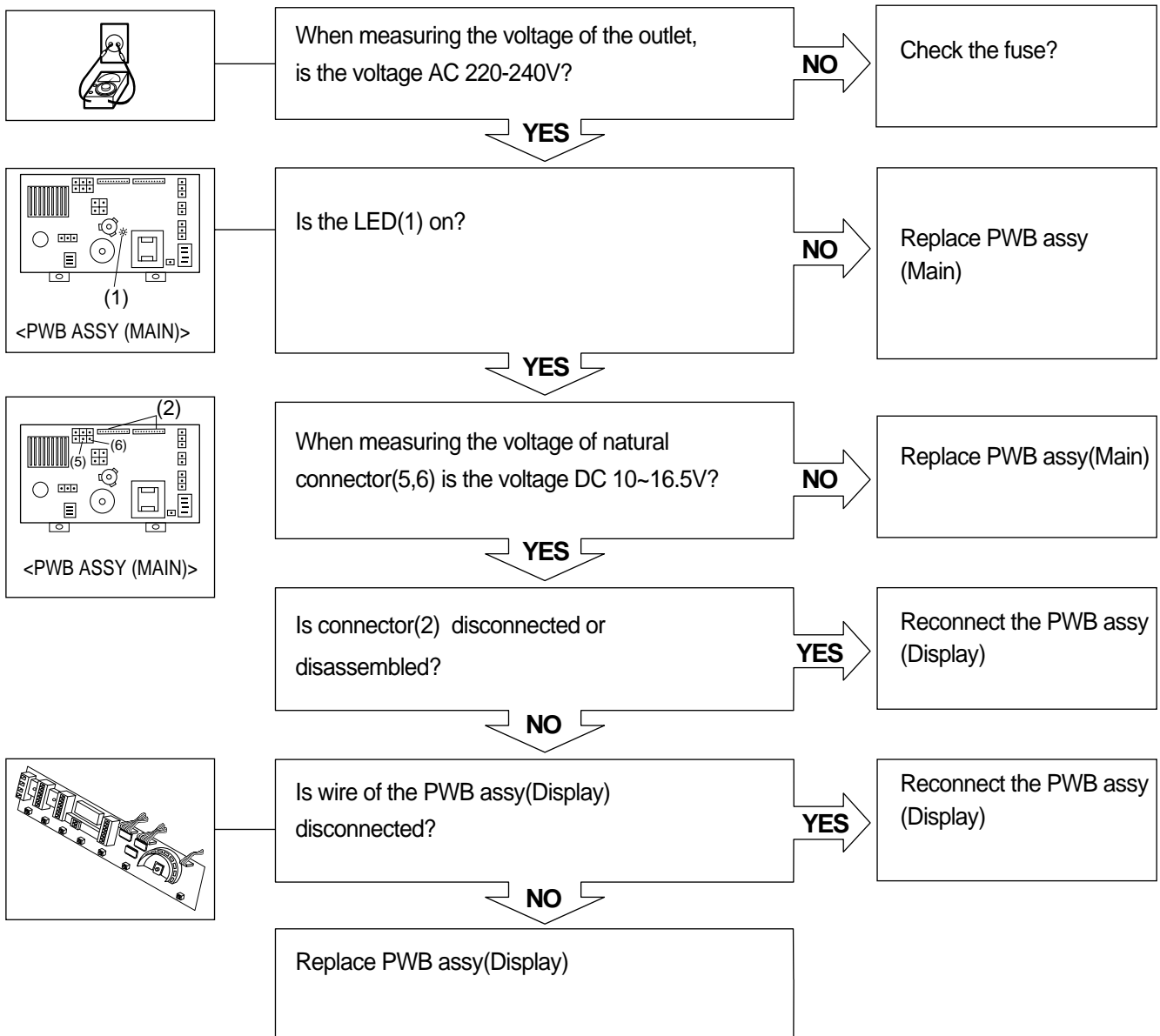

■ WD-8070F(H), WD-1070(5)F(H)

**CAUTION**

1. Be careful of electric shock or disconnecting the parts while trouble shooting.
2. First of all, check the connection of each part terminal with wiring diagram.
3. Voltage between each terminal is AC 220-240V while applying an electric current (except secondary part of the transformer and sensors)

**NO POWER**

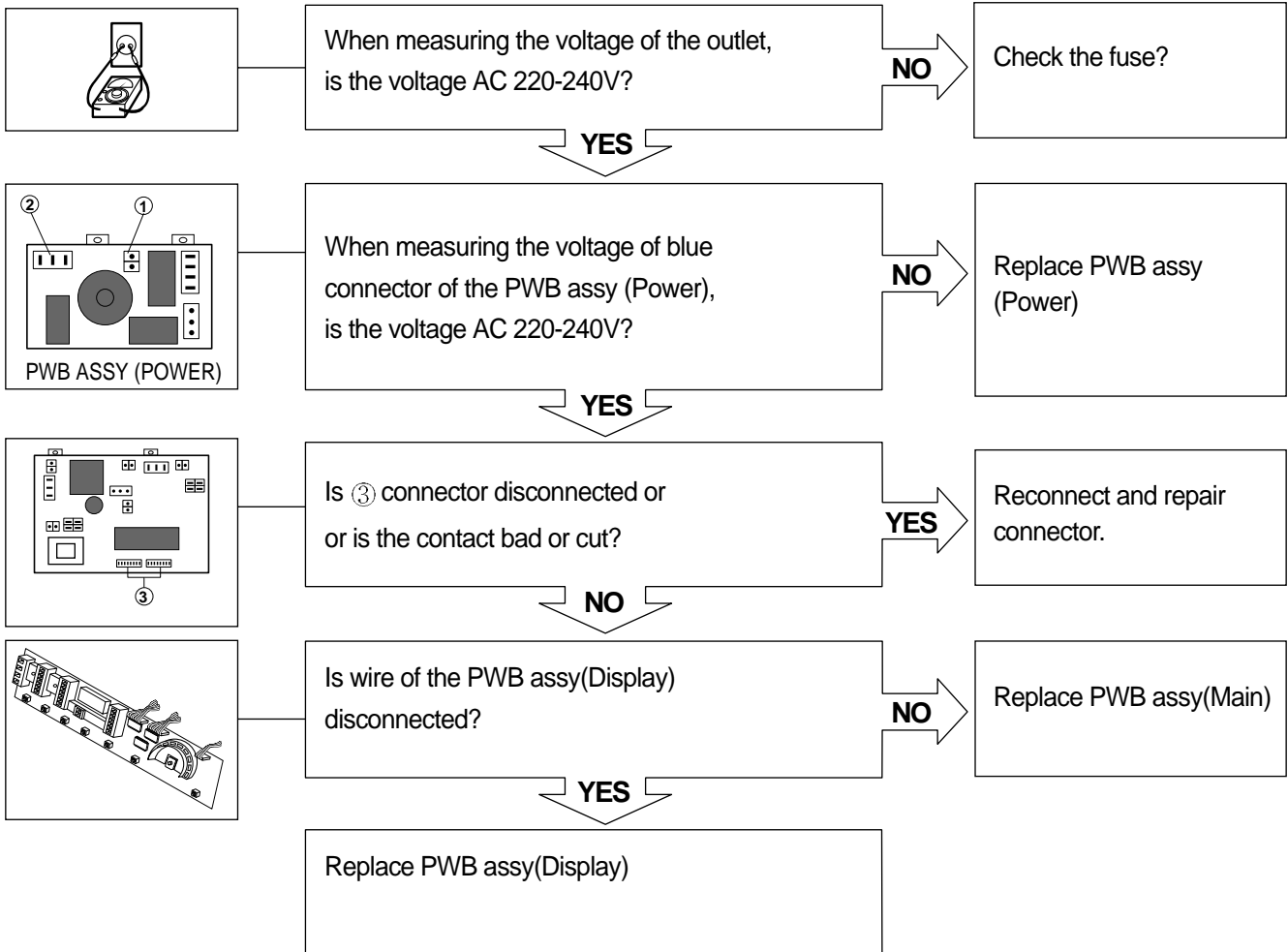

## NO WATER SUPPLY

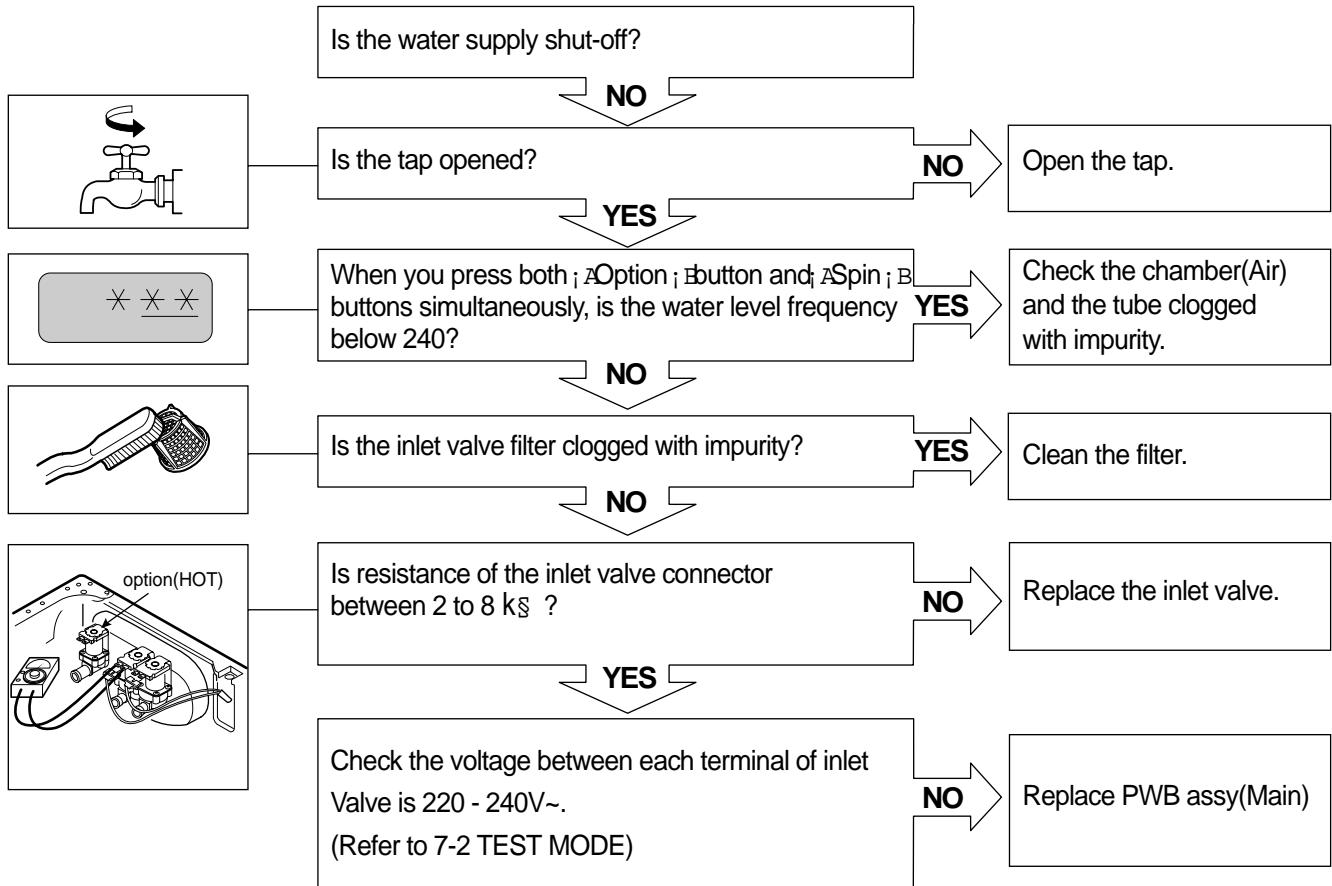

## DETERGENT DOES NOT FLOW IN

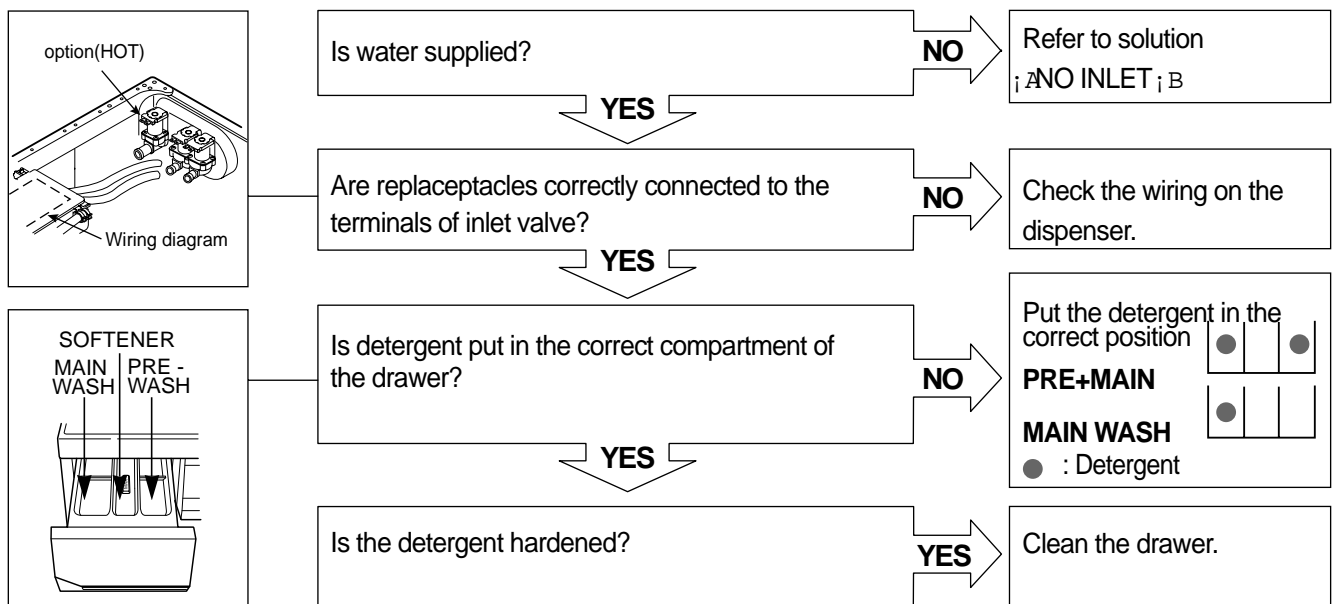



## SOFTENER DOES NOT FLOW IN

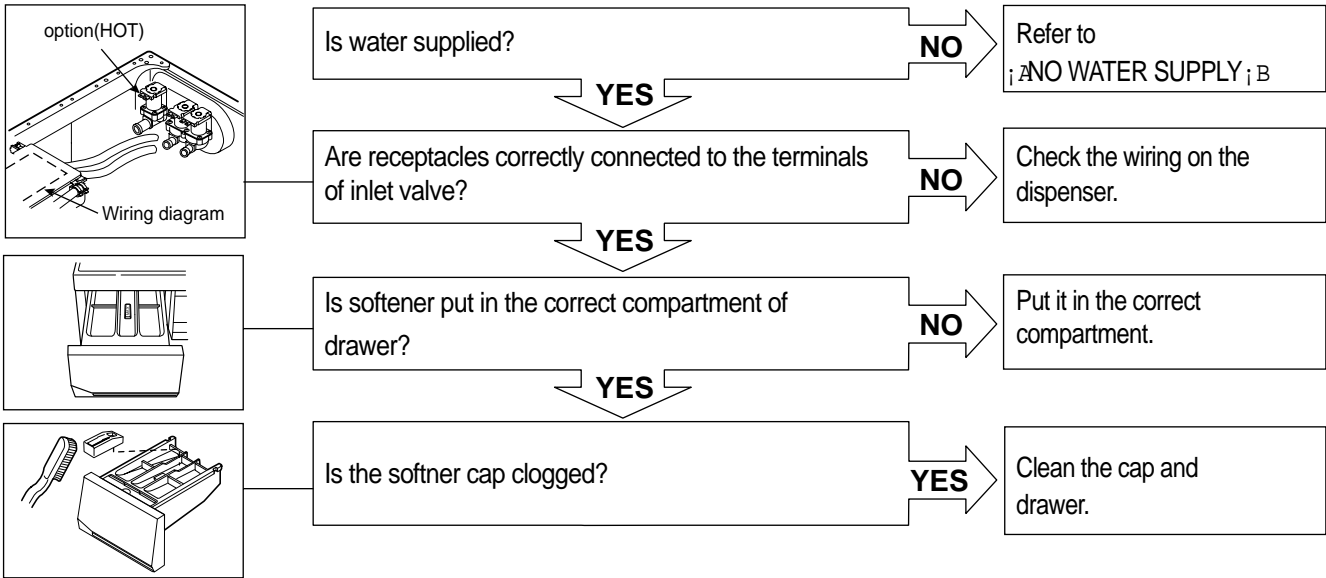

## ABNORMAL SOUND

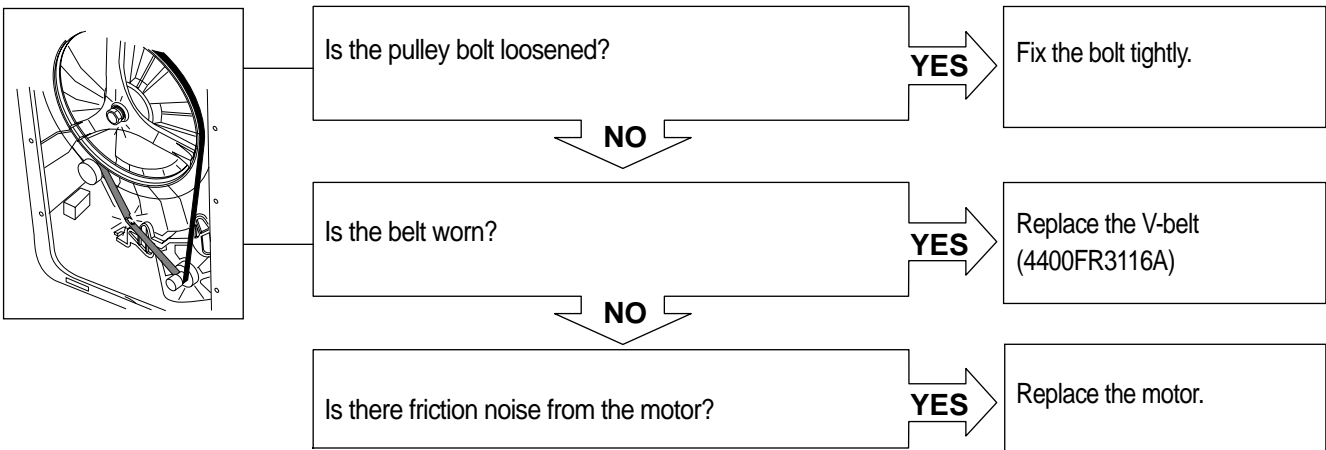

## HEATING WITHOUT WATER

■ WD(M)-8070F(H)B, WD(M)-1070(5)F(H)B, WD(M)-1170(5)F(H)B, WD(M)-1270(5)F(H)B, WD(M)-1370(5)F(H)B

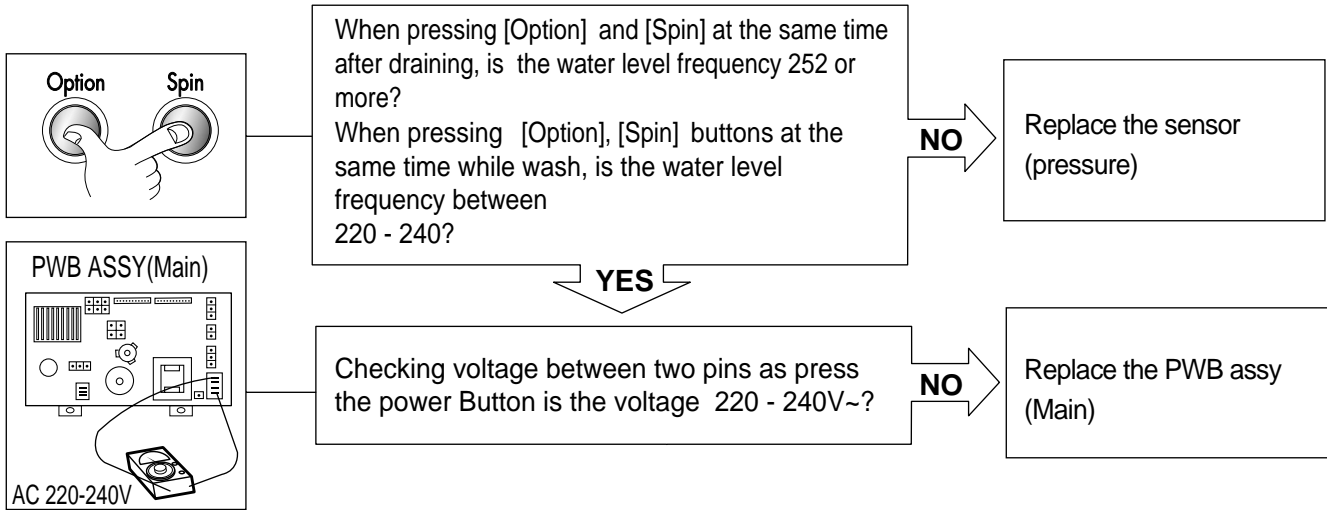

■ WD-8070F(H), WD-1070(5)F(H)

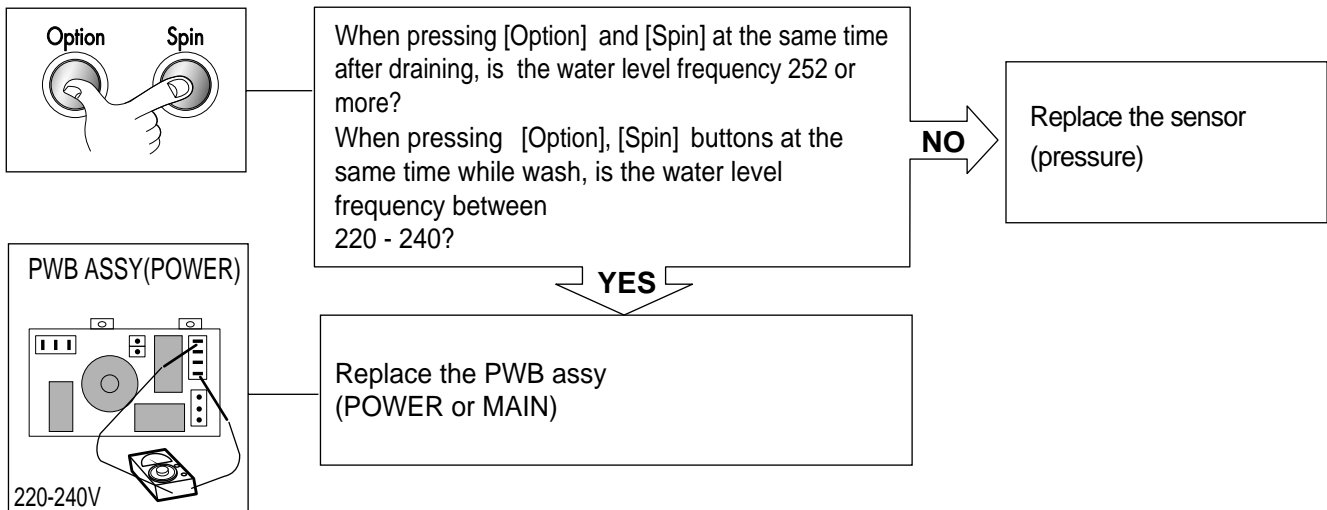

## DRAIN MALFUNCTIONING

■ WD(M)-8070F(H)B, WD(M)-1070(5)F(H)B, WD(M)-1170(5)F(H)B, WD(M)-1270(5)F(H)B, WD(M)-1370(5)F(H)B

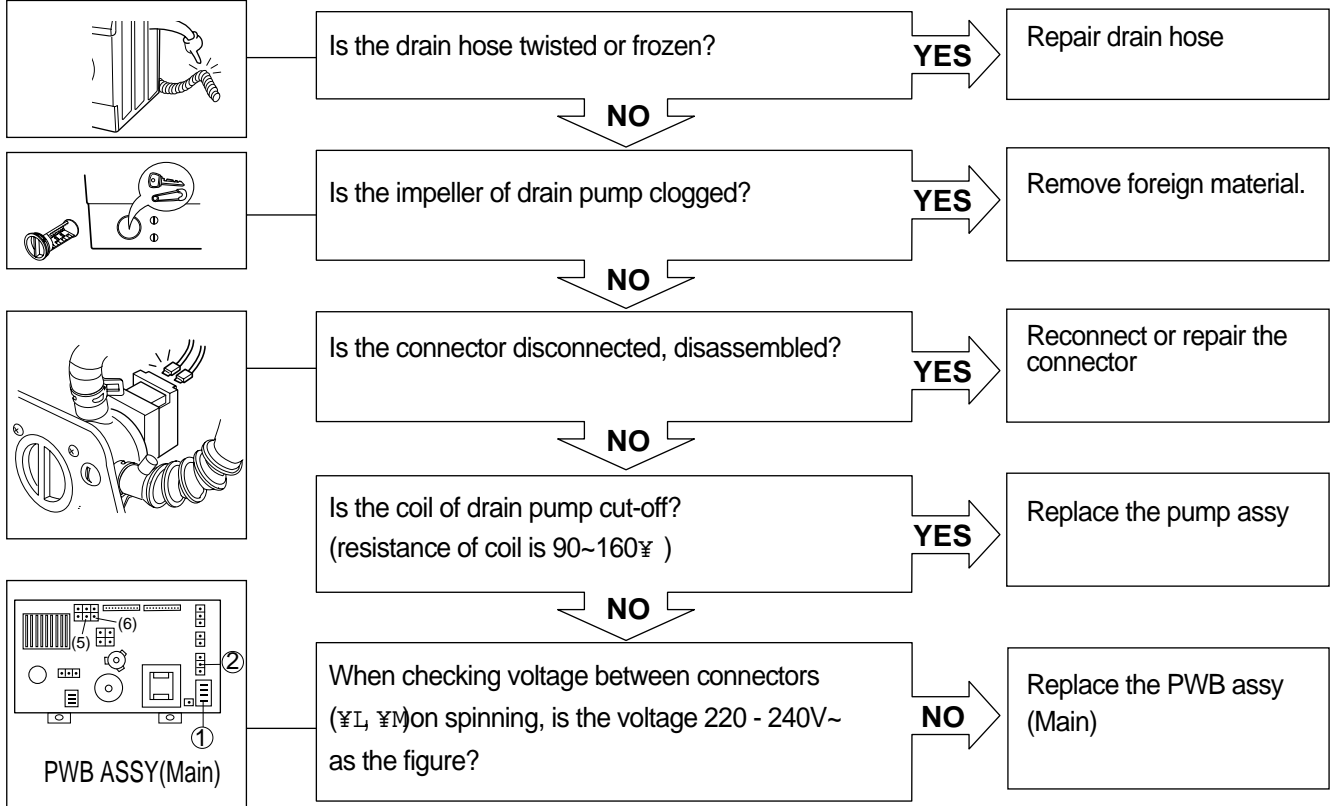

■ WD-8070F(H), WD-1070(5)F(H)

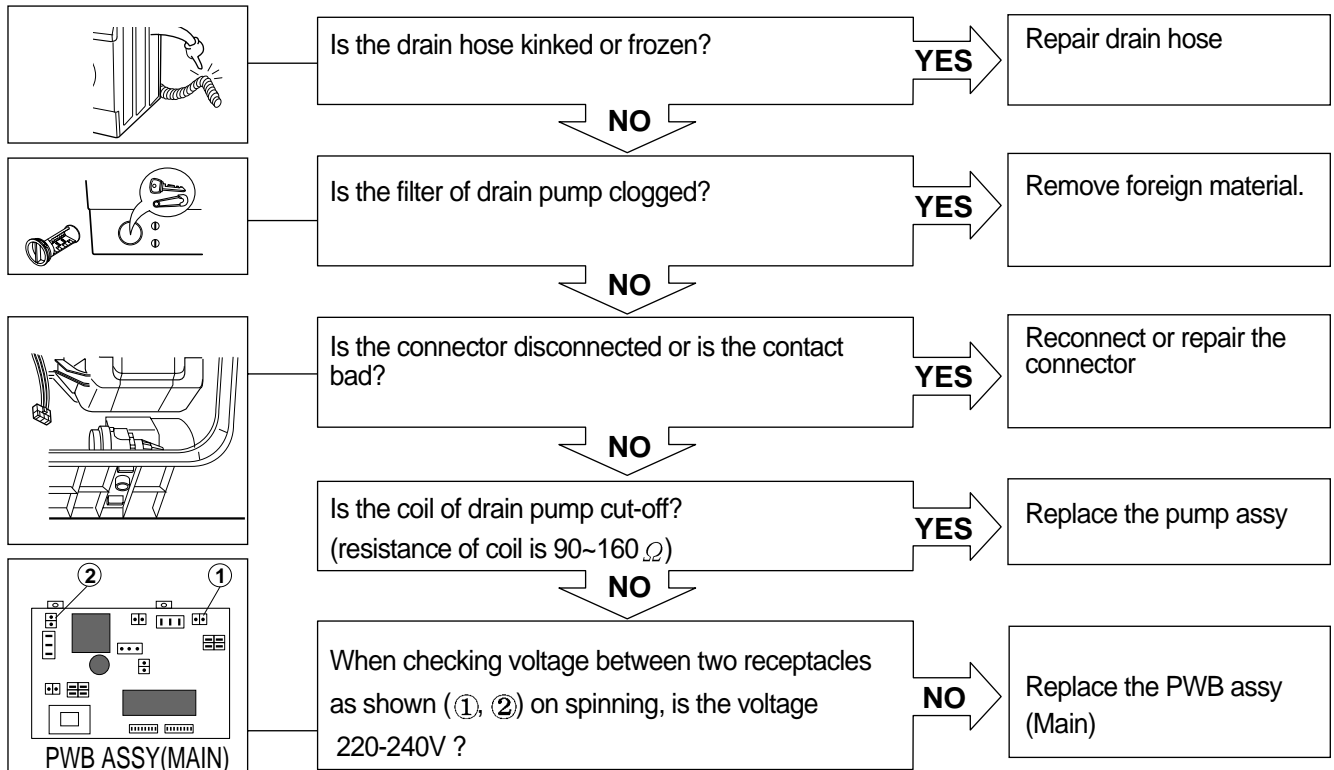

## WASH HEATER TROUBLE

■ WD(M)-8070F(H)B, WD(M)-1070(5)F(H)B, WD(M)-1170(5)F(H)B, WD(M)-1270(5)F(H)B, WD(M)-1370(5)F(H)B

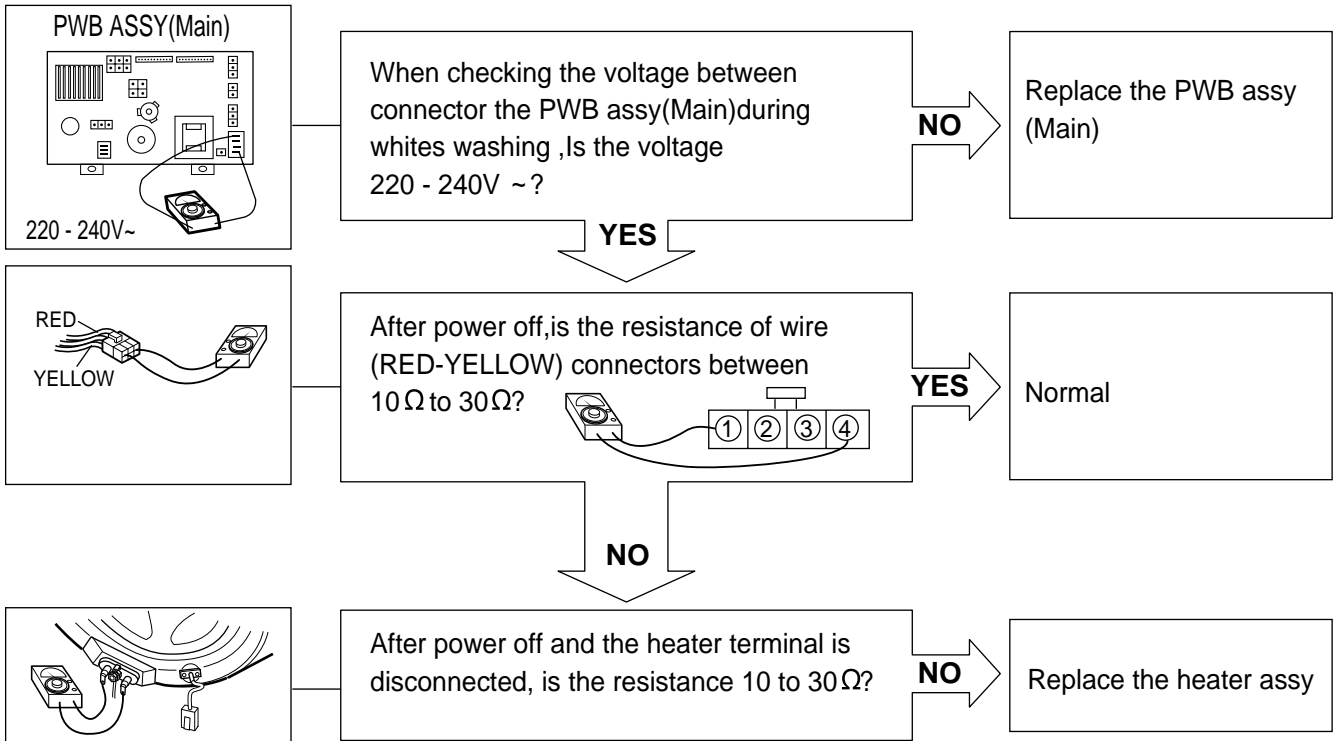

■ WD-8070F(H), WD-1070(5)F(H)

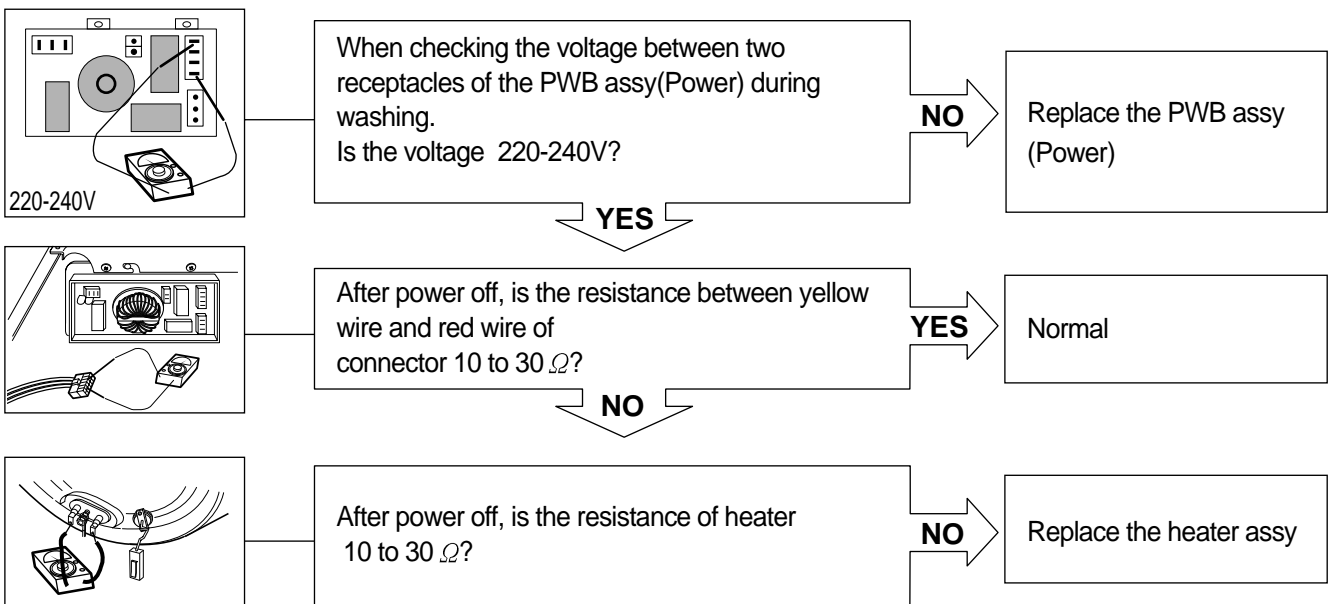

## HEATING CONTINUOUSLY ABOVE THE SETTING WATER TEMPERATURE

### ■ WD(M)-8070F(H)B, WD(M)-1070(5)F(H)B, WD(M)-1170(5)F(H)B, WD(M)-1270(5)F(H)B, WD(M)-1370(5)F(H)B

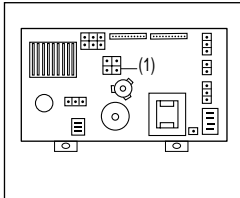

When disconnect the connector(1) on the PWB assy (Main) is the resistance of the Natural connectors;  $\square$  ( Blue/White, Violet),  $\square$  (Blue, White); between 2.5k $\Omega$  to 180k $\Omega$  (105; ~0; )?

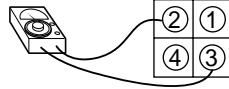

**NO**

Replace the thermistor (6322FR2046B)

**YES**

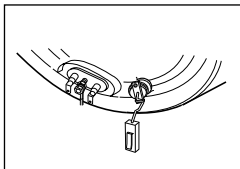

When checking thermistor on the tub cover, is the thermistor loosened above 2mm from the rubber?

**YES**

Push the thermistor tightly to the rubber.

### ■ WD-8070F(H), WD-1070(5)F(H)

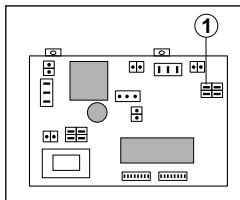

Is the resistance between two receptacles with BL/WH wires parted from PWB assy 2.5k $\Omega$  to 180k $\Omega$  (105°C~0°C)?

**NO**

Replace the thermistor (6322FR2046B)

**YES**

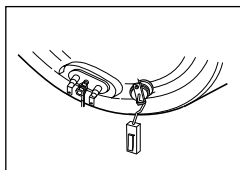

When checking thermistor on the tub cover, is the thermistor gotten more than 2 mm out of the rubber?

**YES**

Get the thermistor back to the rubber.

## SPIN TROUBLE

■ WD(M)-8070F(H)B, WD(M)-1070(5)F(H)B, WD(M)-1170(5)F(H)B, WD(M)-1270(5)F(H)B, WD(M)-1370(5)F(H)B

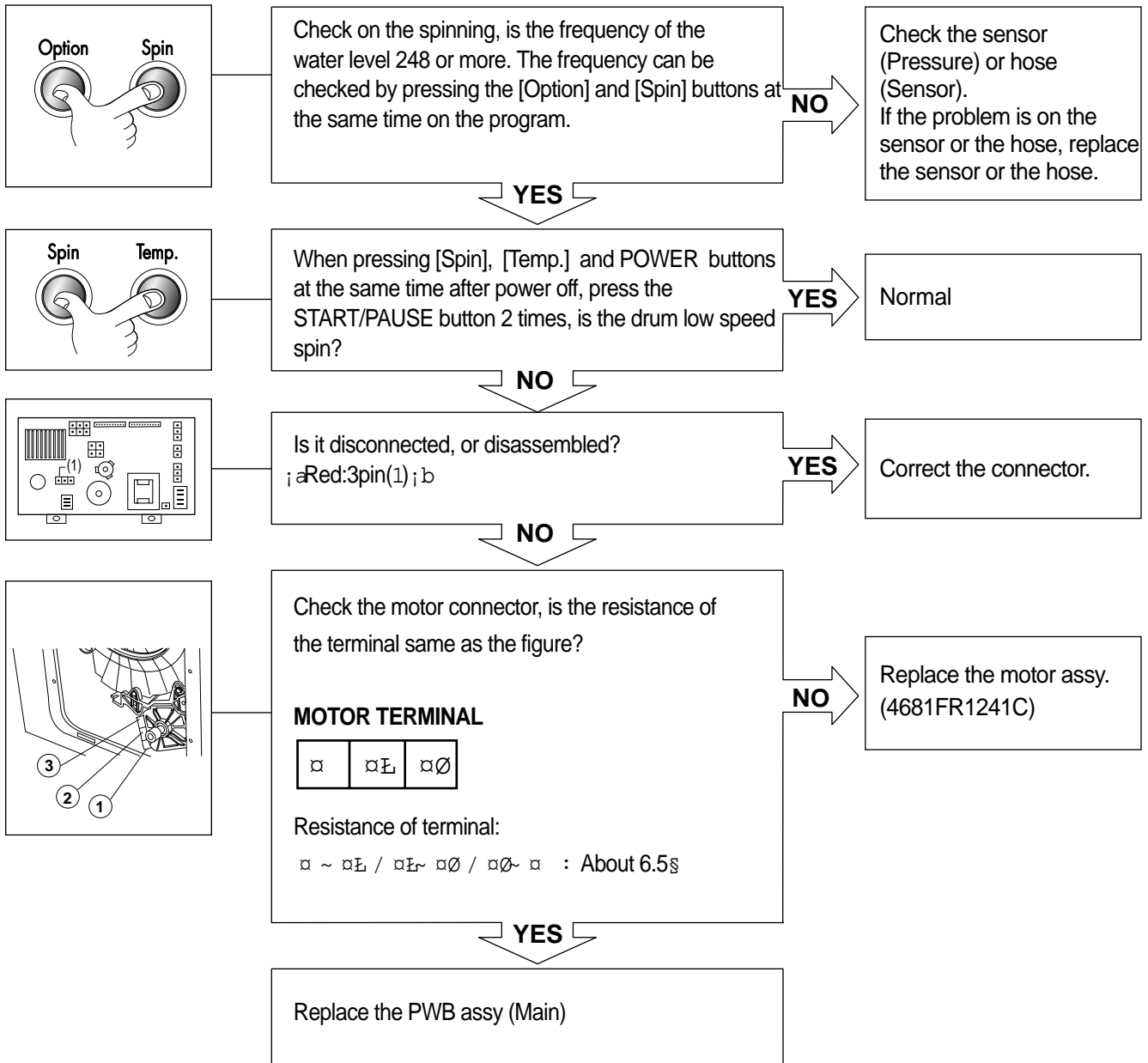

■ WD-8070F(H), WD-1070(5)F(H)

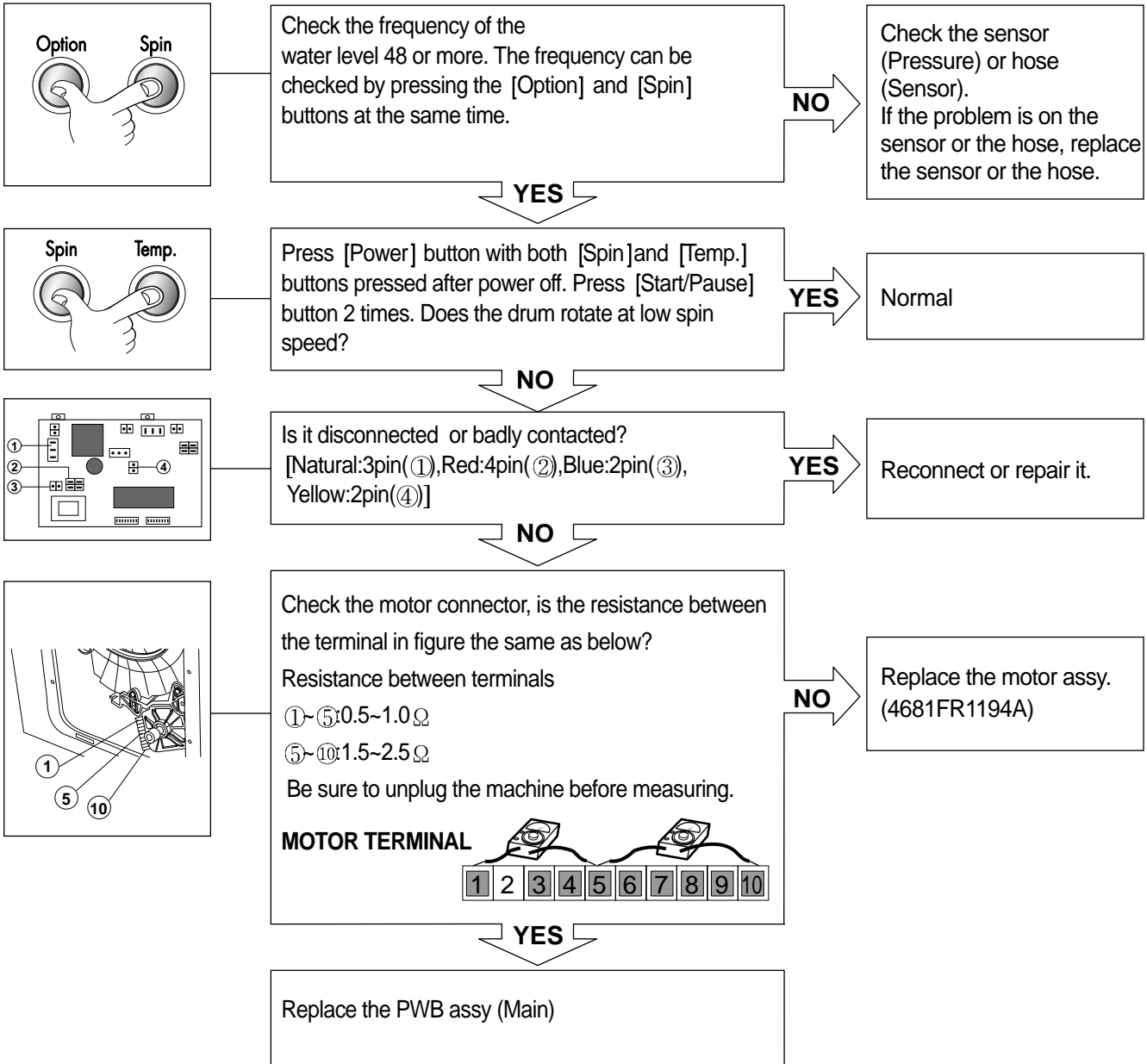

# 10. DISASSEMBLY INSTRUCTIONS

\* Be sure to unplug the machine out of the outlet before disassembling and repairing the parts.

## CONTROL PANEL

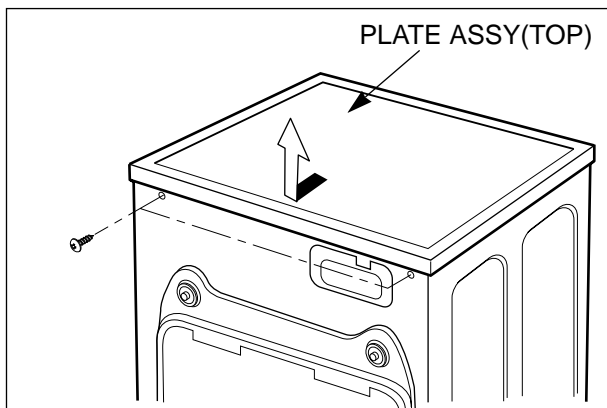

- ① Unscrew 2 screws on the back of the top plate.
- ② Pull the top plate backward and upward as shown.

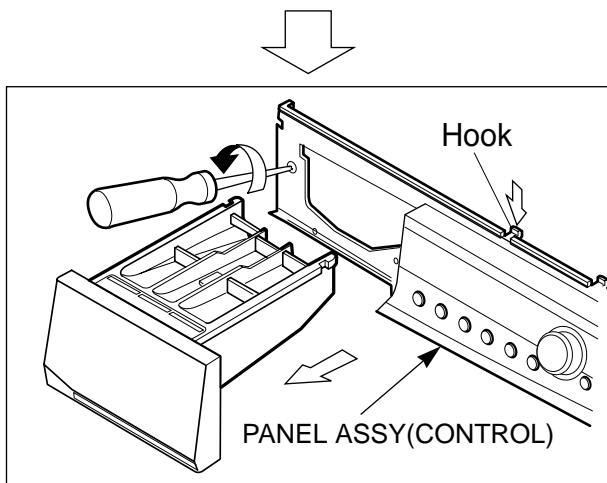

- ① Disconnect the PWB assy (Display) connector.
- ② Pull out the drawer and unscrew 3 screws.
- ③ Push 2 upper hooks down and pull the control panel.

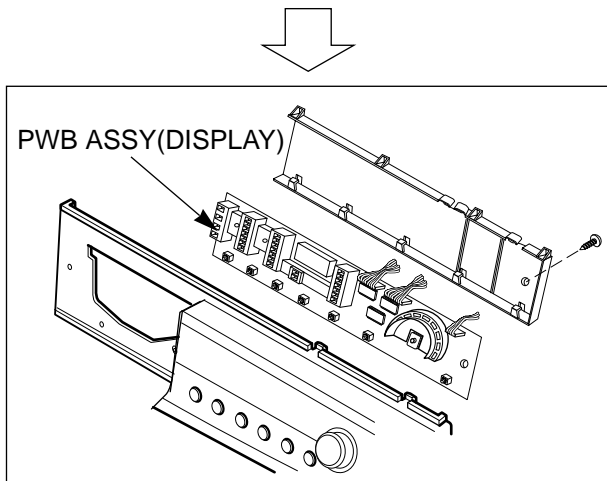

- ① Pull out the Rotary (Dial) knob.
- ② Disconnect the PWB assy (Display) from the control panel by pushing 5 hooks down and unscrewing 1 screw.



## PWB ASSY(POWER)

■ WD-8070F(H), WD-1070(5)F(H)

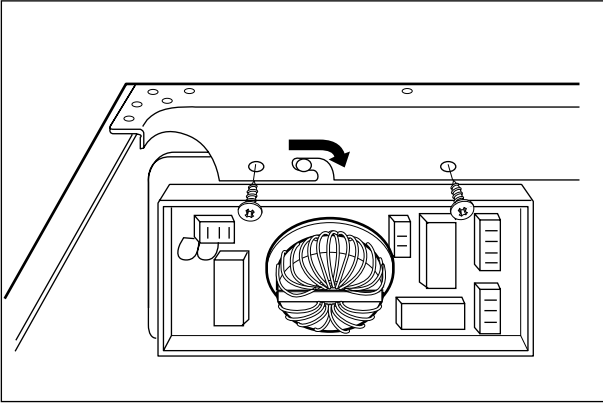

- ① Disassemble the top plate assy.
- ② Unscrew 2 screws.
- ③ Disconnect connector from the wiring.

## DISPENSER ASSY

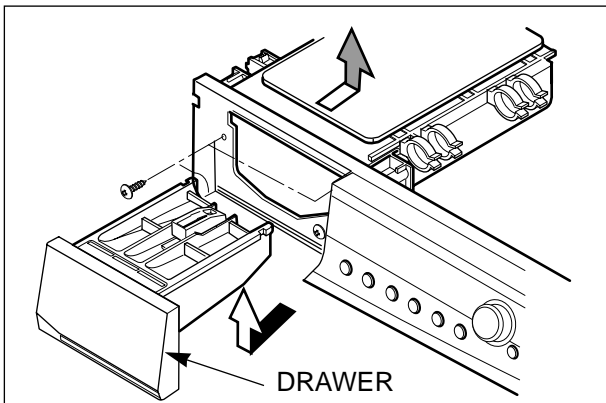

- ① Disassemble the top plate assy.
- ② Pull out the drawer to arrow direction.
- ③ Unscrew 2 screws.

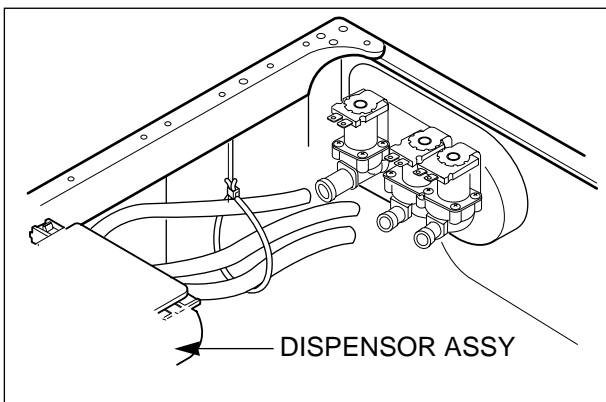

- ① The hose clamps and the hose are disassembled.
- ② The ventilation bellows and the water inlet bellows are disassembled on the tub.

## INLET VALVE

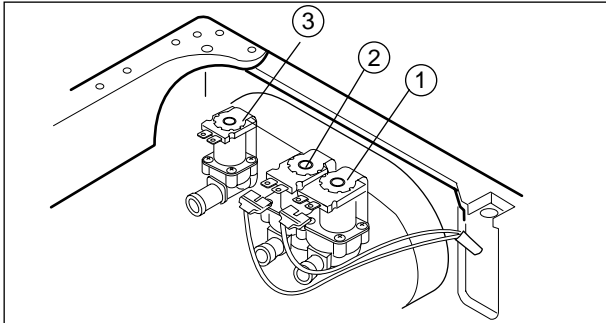

- ① Disconnect the wiring receptacle.
- ② Unscrew 2 screws from the back.
- ※ When reconnecting the connector

VALVE #1(MAIN)	Whited/Black-Black
VALVE #2(PRE)	Gray/ White - Black
VALVE #3(HOT)	Blue/Red - Black

[WD-8070FH/WD-1070(5)FH(B)/WD(M)-1170(5)F(H)B /  
WD(M)-1270(5)F(H)B / WD(M)-1370(5)F(H)B]

## PWB ASSY(MAIN)

■ WD(M)-8070F(H)B, WD(M)-1070(5)F(H)B, WD(M)-1170(5)F(H)B, WD(M)-1270(5)F(H)B, WD(M)-1370(5)F(H)B

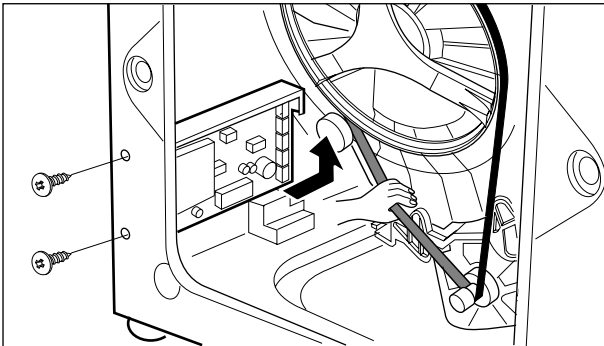

- α The back cover is removed.
- α ± Unscrew 2 screws
- α ∅ Pull the PWB assy (Main) as shown.

■ WD-8070F(H), WD-1070(5)F(H)

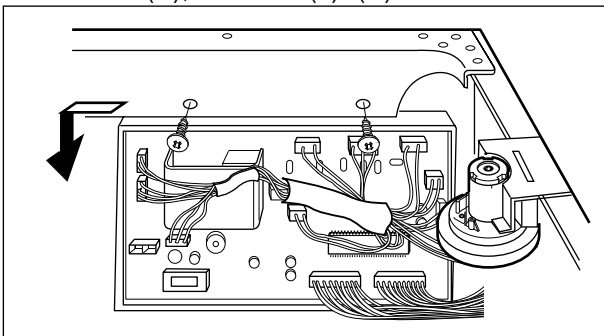

- ① Unscrew 2 screws
- ② Pull the PWB assy(Main) as shown.

## LOWER COVER

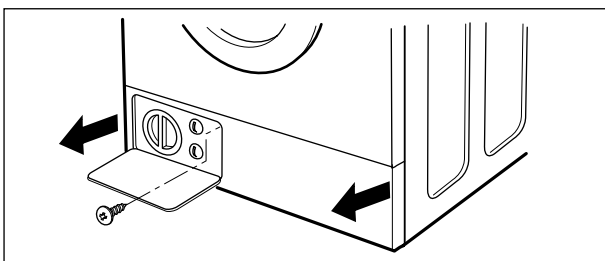

- Open the lower cover plate by using coin and pull out the lower cover in the arrow direction after a screw is unscrewed.

## DOOR

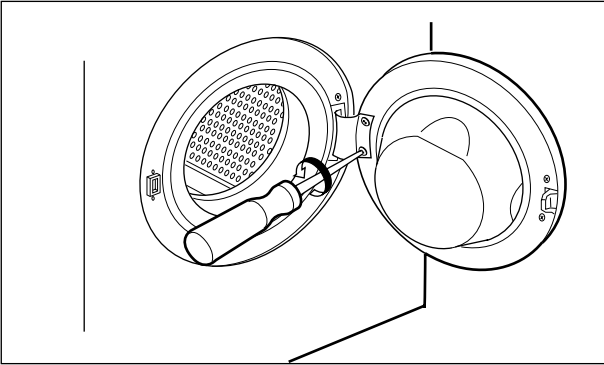

- ① Open the door completely.
- ② Remove the two screws from the hinge.

## GASKET ASSY

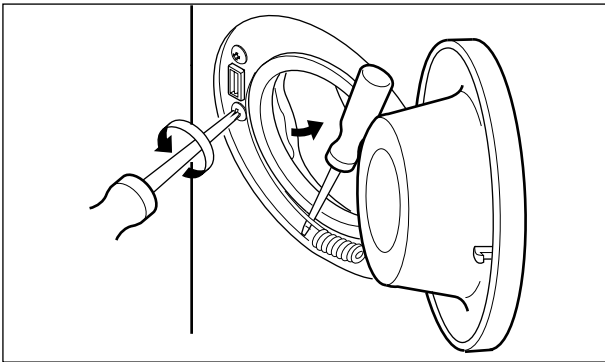

- ① Take apart the cabinet gasket clamp.
- ② Unscrew 2 screws from the cabinet cover.
- ③ Open the lower cover cap and unscrew 1 screw inside
- ④ Take apart the lower cover

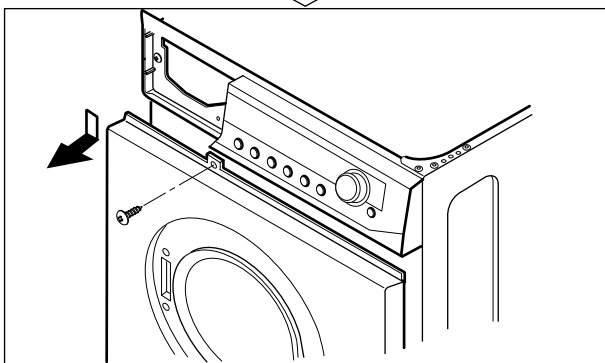

- ① Unscrew all the screws on the upper and lower sides of the cabinet cover.

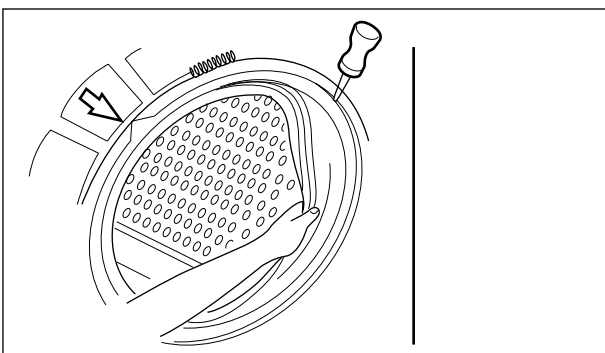

- ① Take apart the tub gasket clamp
  - ② Make sure that the drain hole of the gasket is put beneath when reassembling the gasket.
- ※Refer to the arrow mark on the tub cover.

## PULLEY, MOTOR, DAMPER

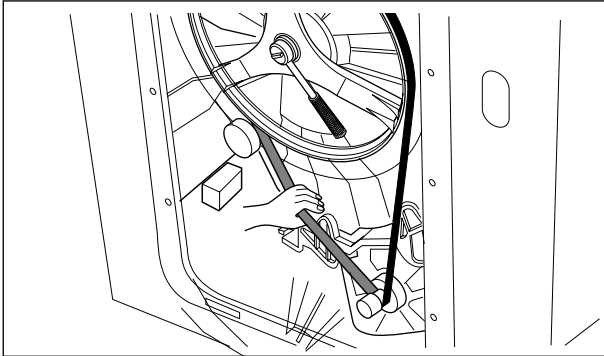

(PULLEY)

- ① Remove the back cover.
- ② Take off the belt turning the pulley.
- ③ Unscrew the bolt to pull out the pulley.

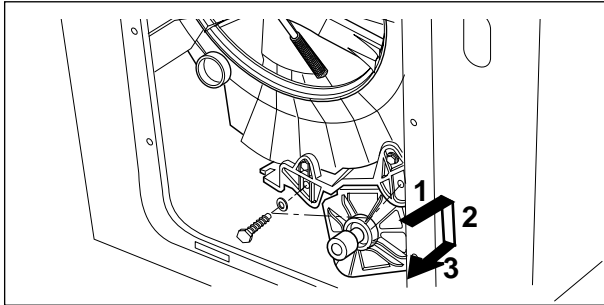

(MOTOR)

- ① Unscrew 2 screws from the bracket.
- ② Push the motor in the arrow direction for disassembling.
- ③ When reassembling the motor, make sure that motor mounting rubbers are not taken off from the bracket.

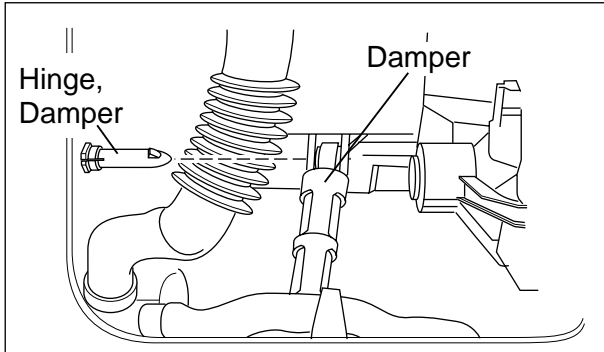

(DAMPER)

- ① Pull out the hinge pressing its snap.
- ② Do not use the pulled out hinge again..it may be taken off during operation.

## ■ Clean the drain pump filter

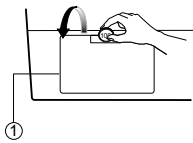

Open the lower cover cap ( ㉞L ) by using coin.

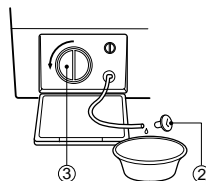

Unplug the drain plug ( ㉞M ), then the water flows out, At this time use a vessel to prevent water flowing on the floor. If the water does not flow any more, turn the pump filter ( ㉞N ) open to the left.

Take out any foreign material

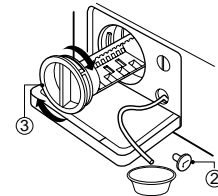

from the pump filter ( ㉞N ). After cleaning, turn the pump filter ( ㉞N ) clockwise and insert the drain plug ( ㉞M ) to the original place. close the lower cover cap.

## PUMP

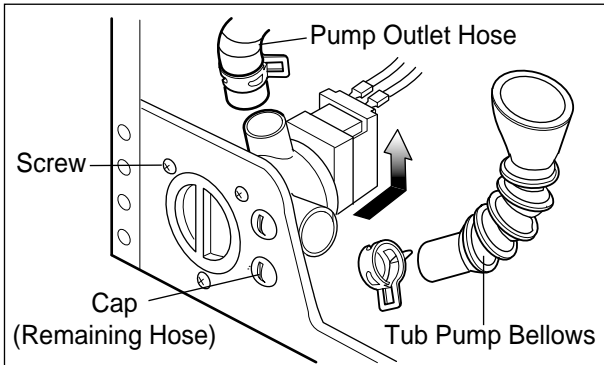

- ① Remove pump outlet hose.
- ② Remove tub pump bellows.
- ③ Remove cap(Remaining Hose.)
- ④ Disconnect the wiring.
- ⑤ Unscrew 3 screws
- ⑥ Remove the pump.

## HEATER

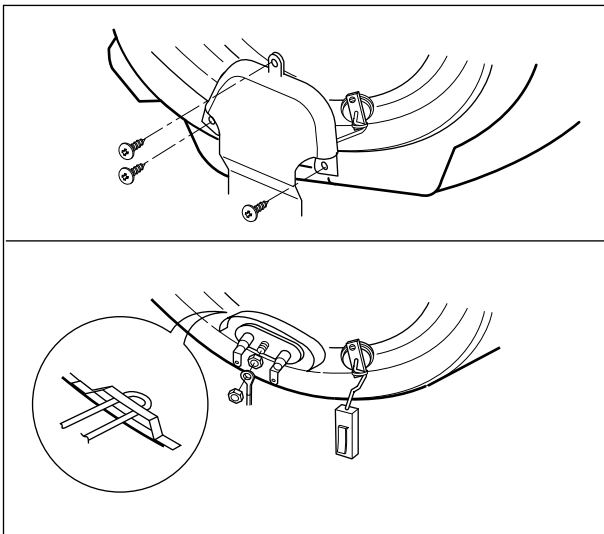

- ① Unscrew 3 screws fixing the heater protecting cover.
- ② Loosen the M6 heater nut to pull out the heater.

### CAUTION

When mounting the heater, be sure to insert the heater into the heater clip on the bottom of the tub.

## THERMISTOR

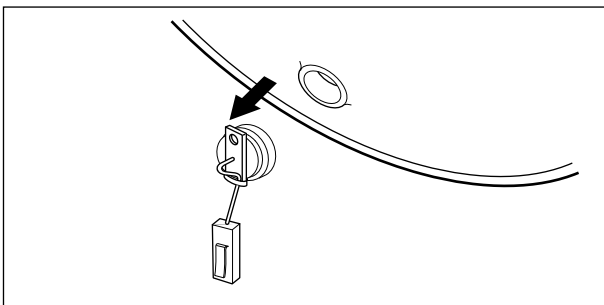

- ① Pull it out by holding the thermistor bracket.
  - \* If it is pulled by the wire, it may be broken.
- ② When mounting the thermistor again, make sure that it is got back tight to the rubber.

## DOOR HINGE ASSY

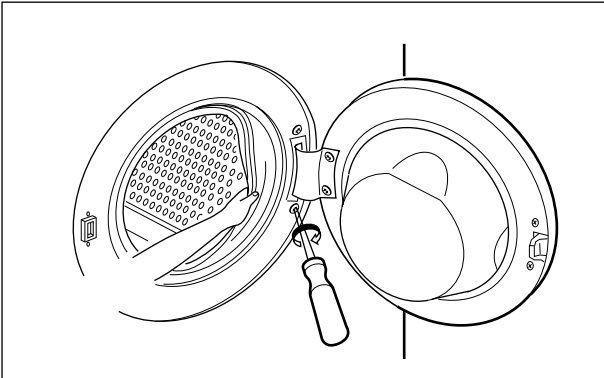

- ① Disassemble the door from the door hinge.
- ② Take apart the cabinet cover clamp and release the gasket.
- ③ Unscrew 2 screws on the door hinge.
- ④ Push the door hinge arm to the inside of the cabinet cover for disassembling.

## SWITCH ASSY, DOOR LOCK

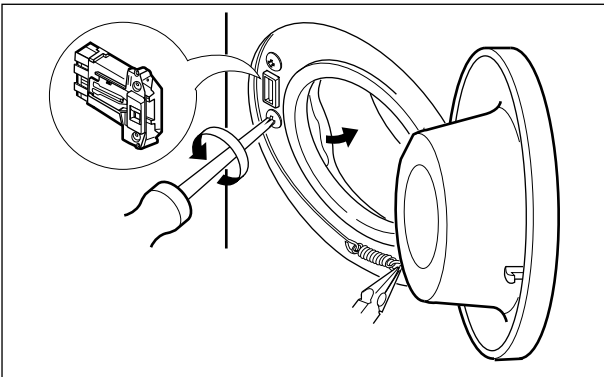

- ① Take apart the cabinet cover clamp and release the gasket.
- ② Unscrew 2 screws holding the Door Lock.
- ③ Disconnect the door lock from the wiring connector.

## WHEN FOREIGN MATERIAL IS STUCK BETWEEN DRUM AND TUB

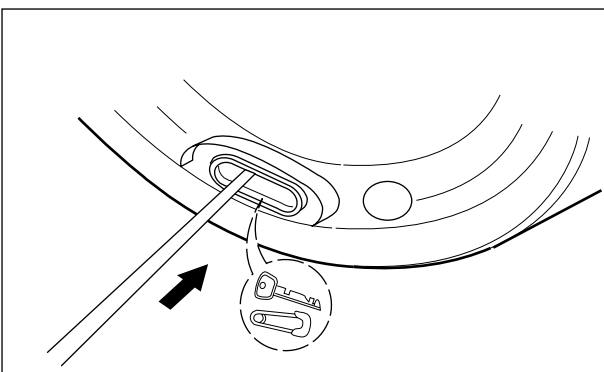

- ① Remove the heater.
- ② Remove the foreign material (wire, coin and others) by inserting a long bar through the hole.



# 11-2 THE EXPLODED VIEW OF CONTROL PANEL & DISPENSER ASSY

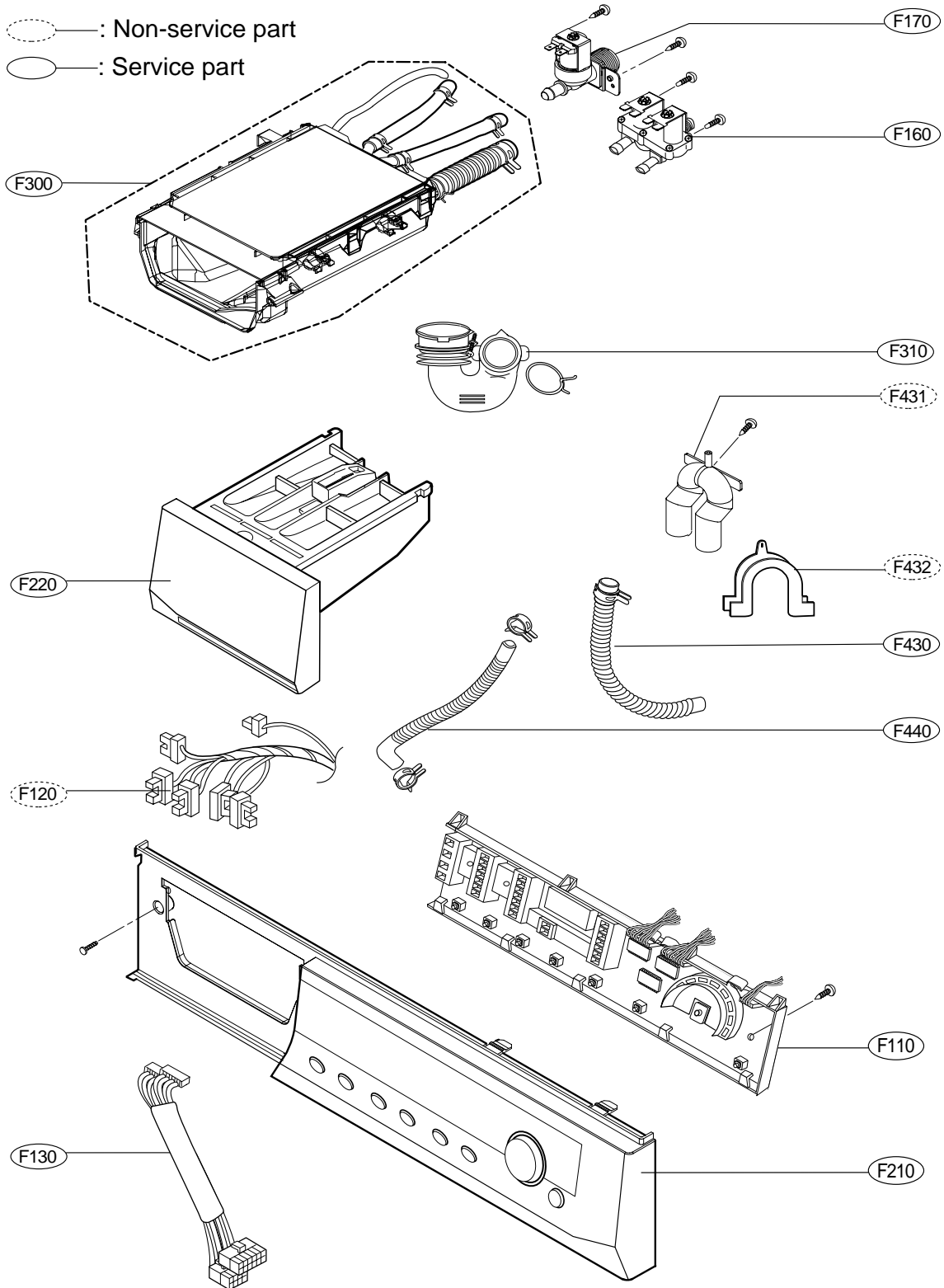



# 11-3 THE EXPLODED VIEW OF DRUM & TUB ASSY

○ : Non-service part  
 ○ : Service part

