

SERVICE NOTE BOOK

**DUAL FUEL SELF-CLEAN FREE STANDING RANGES
WITH SEALED BURNERS**

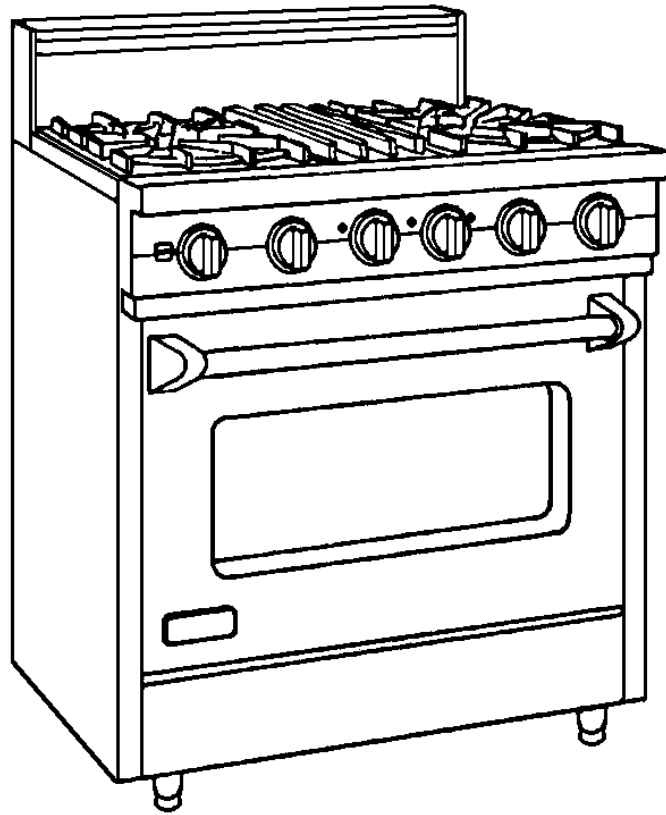

VIKING RANGE CORPORATION ®



VIKING RANGE CORPORATION, P. O. DRAWER 956, GREENWOOD, MS.38930 USA

TABLE OF CONTENTS

TABLE OF CONTENTS -----	3
Customer Information-----	4
VIKING Model Numbers-----	5
Product Warranties-----	6 / 7
Proximity to Adjacent Cabinets-----	8
Wood/Composite Overlay-----	9

COMPONENTS/COLOR CODED WIRES

Control Circuit Board (PC Board)-----	10
Auto Reset-----	10
High Limit Switches-----	11
Cooling Fan Limit Switch-----	11
Selector Switch-----	11
Oven Thermostat-----	11
Door Lock Motor-----	12
Relays 1 through 6-----	12 / 13
Convection Fan Motor-----	14
Cooling Fan Motor-----	14
Oven Light-----	14
Control Board Wiring-----	15
Control Board Voltage Readings-----	16
8-Position Selector Switch (shaft position and internal connections)-----	17
Oven Calibration-----	18
VDSC307 Component Location-----	19
VDSC307 Relay Circuit Connections-----	19
VDSC485 Component Location-----	20
VDSC485 Relay Circuit Connections-----	20

Dual Fuel Oven Element Voltage and Resistance Readings-----	21
VDSC307 Dual Fuel Wiring Diagram-----	22
VDSC485 Dual Fuel Wiring Diagram-----	23

BREAK OUT WIRING DIAGRAMS

Bake / Convection Bake / Convection Cook Mini Broil-----	24
Maxi Broil / Convection Broil / Clean Initiate Door Lock / Clean Lock Below 575°F-----	25
Clean Lock Above 575°F / Clean Finish Above 575°F / Clean Finish Below 575°F / Surface Wiring-----	26

ELECTRICAL CONNECTIONS

3-Wire Power Supply Cord-----	27
4-Wire Power Supply Cord-----	27

ELECTRICAL CONNECTIONS (CONDUIT)

3-Wire Power Connections-----	28
4-Wire Power Connections-----	28

**VDSC307 RANGE TOP &
SELF-CLEAN LOCK SERVICE**

LP/Propane Conversion-----	29
Back guard Assembly / Grates / Burner Head and Cap-----	30
Venturi / Burner Base Removal-----	31
Maintop Removal-----	32
Spark Module Replacement-----	32
Landing Ledge / Main Top Access-----	33
Component Location-----	34
Self-clean Lock Service-----	35
Surface Gas Supply Components-----	36
VDSC “Locked Door”-----	37

TROUBLESHOOTING GUIDE----- 38 / 40

IMPORTANT INFORMATION

The information contained in this manual is intended for use by a qualified service technician who is familiar with the application of all safety procedures required in the repair of any gas or electric appliance, and who is equipped with the proper tools and testing instruments.

Repairs covered in this manual and made by unqualified persons can result in hazards developing due to improper assembly or adjustment.

Inexperienced persons making such repairs subject themselves to the risk of injury or electrical shock which can be serious or even fatal.

IMPORTANT NOTE TO CUSTOMER

If you perform service on your own Viking product, you must assume responsibility of personal injury or property damage which may result.

Viking will not be responsible for injury or property damage arising from service performed by other than Viking Factory Authorized Service Agencies.

In order to locate a Viking Factory Authorized Service Agency, please consult the dealer from whom you purchased this product. You may also write to:

Viking Preferred Service
P.O. Drawer 956
Greenwood, Ms. 38930

VIKING MODEL NUMBERS

RANGES AND RANGETOPS

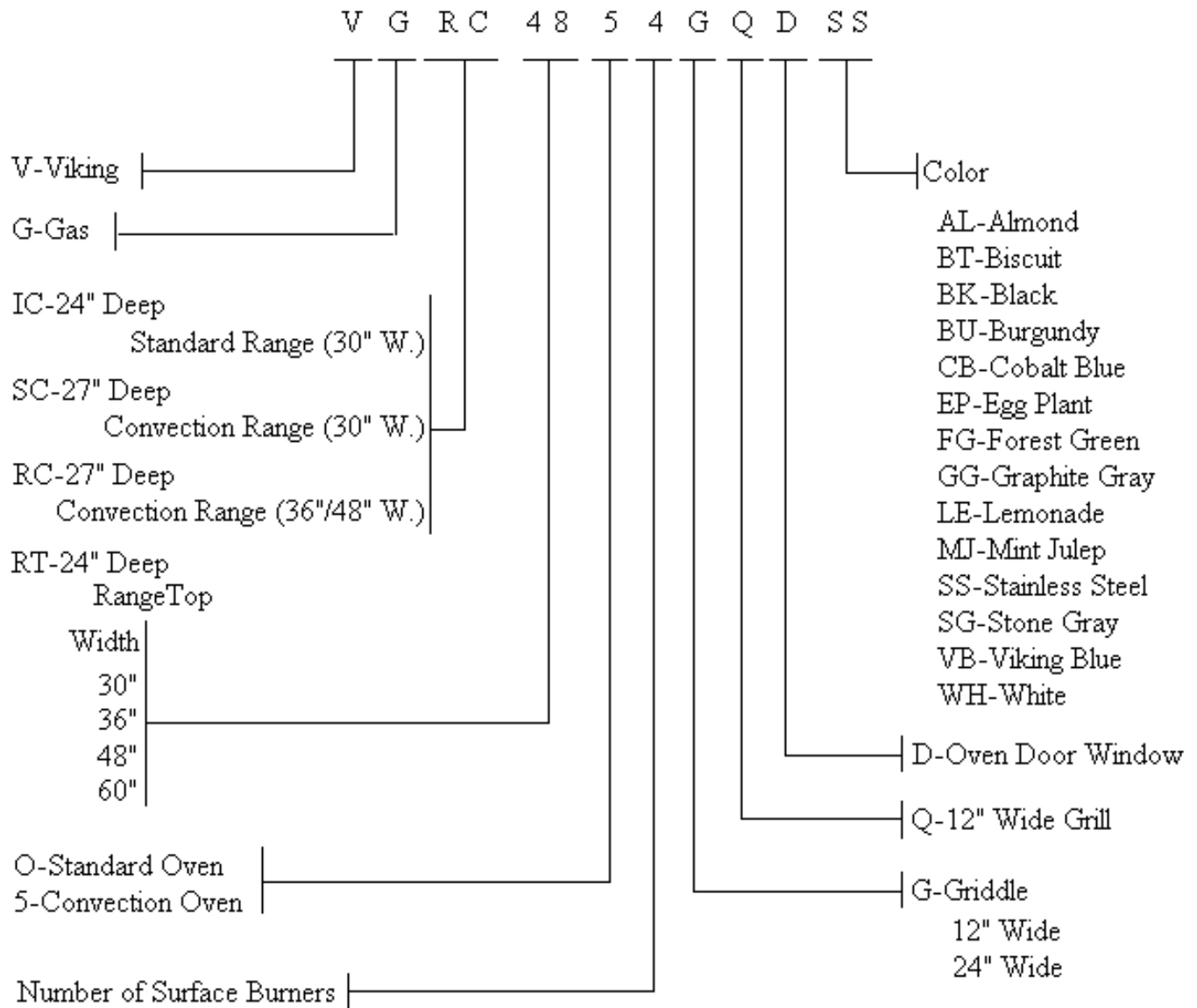

VIKING SERIAL NUMBER LOGIC

RANGES and WALL OVENS

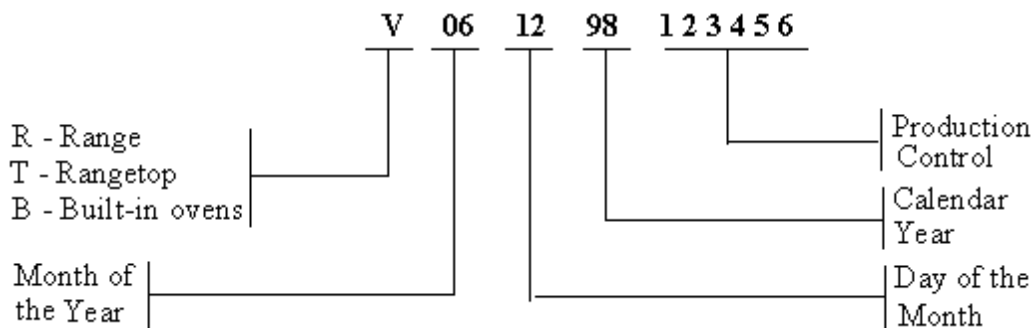

VIKING RANGE CORPORATION PRODUCT WARRANTY COOKING PRODUCTS

FREE STANDING GAS RANGES

- * 90 DAYS-GLASS, PAINTED, PORCELAIN AND DECORATIVE ITEMS
- * 1 YEAR FULL WARRANTY-COMPONENTS AND ACCESSORIES
- * 5 YEAR LIMITED WARRANTY-SURFACE BURNER, GRIDDLE TUBULAR BURNER, GRILL TUBULAR BURNER (PART ONLY)
- 10 YEAR LIMITED WARRANTY-ANY PORCELAIN OVEN OR PORCELAIN INNER DOOR WHICH **RUSTS THROUGH**

DUAL FUEL RANGES

- * 90 DAYS-GLASS, PAINTED, PORCELAIN AND DECORATIVE ITEMS
- * 1 YEAR FULL WARRANTY-COMPONENTS AND ACCESSORIES
- * 5 YEAR LIMITED WARRANTY-SURFACE BURNER, GRIDDLE TUBULAR BURNER, GRILL TUBULAR BURNER, BAKE ELEMENT, BROIL ELEMENT, OR CONVECTION COOK ELEMENT (PART ONLY)
- * 10 YEAR LIMITED WARRANTY-ANY PORCELAIN OVEN OR PORCELAIN INNER DOOR PANEL WHICH **RUSTS THROUGH**

ELECTRIC RANGES

- * 90 DAYS-GLASS, PAINTED, PORCELAIN AND DECORATIVE ITEMS
- * 1 YEAR FULL WARRANTY-COMPONENTS AND ACCESSORIES
- * 5 YEAR-ANY HALOGEN ELEMENT, BAKE ELEMENT, BROIL ELEMENT, OR CONVECTION COOK ELEMENT (PART ONLY)
- * 10 YEAR LIMITED WARRANTY-ANY PORCELAIN OVEN OR PORCELAIN INNER DOOR PANEL WHICH **RUSTS THROUGH**

GAS RANGETOPS

- * 90 DAYS -GLASS, PAINTED, PORCELAIN AND DECORATIVE ITEMS
- * 1 YEAR FULL WARRANTY-COMPONENTS AND ACCESSORIES
- * 5 YEAR LIMITED WARRANTY-SURFACE BURNERS, GRIDDLE TUBULAR BURNER, GRILL TUBULAR BURNER (PART ONLY)

ELECTRIC RANGETOP

- * 90 DAYS-GLASS, PAINTED, PORCELAIN AND DECORATIVE ITEMS
- * 1 YEAR FULL WARRANTY-COMPONENTS AND ACCESSORIES
- * 5 YEAR-ANY HALOGEN ELEMENT, BAKE ELEMENT, BROIL ELEMENT, OR CONVECTION COOK ELEMENT (PART ONLY)

GAS WALL OVENS

- * 90 DAYS-GLASS, PAINTED, PORCELAIN AND DECORATIVE ITEMS
- * 1 YEAR FULL WARRANTY-COMPONENTS AND ACCESSORIES
- * 5 YEARS-OVEN TUBULAR BURNER (PART ONLY)

- * 10 YEAR LIMITED WARRANTY-ANY PORCELAIN OVEN OR PORCELAIN INNER DOOR PANEL WHICH **RUSTS THROUGH**

ELECTRIC WALL OVENS

- * 90 DAYS-GLASS, POINTED, PORCELAIN AND DECORATIVE ITEMS
- * 1 YEAR FULL WARRANTY-COMPONENTS AND ACCESSORIES
- * 5 YEARS LIMITED WARRANTY-OVEN BAKE, BROIL, OR CONVECTION HEATING ELEMENTS
- * 10 YEAR LIMITED WARRANTY-ANY PORCELAIN OR PORCELAIN INNER DOOR PANEL WHICH **RUSTS THROUGH**

WARMING DRAWERS

- * 90 DAYS-PAINTED AND DECORATIVE ITEMS
- * 1 YEAR FULL WARRANTY-COMPONENTS AND ACCESSORIES
- * 5 YEAR LIMITED WARRANTY-HEATING ELEMENT

VENTILATION PRODUCTS

- * 90 DAYS-PAINTED AND DECORATIVE ITEMS
- * 1 YEAR FULL WARRANTY-COMPONENTS AND ACCESSORIES
- * 2 YEAR LIMITED WARRANTY-BLOWER MOTOR OR EXTERIOR VENTILATOR MOTOR

KITCHEN CLEAN -UP

DISHWASHER

- * 90 DAYS-PAINTED OR DECORATIVE ITEMS
- * 1 YEAR FULL WARRANTY-COMPONENTS AND ACCESSORIES
- * 5 YEAR LIMITED WARRANTY-MOTOR/PUMP AND WATER DISTRIBUTION SYSTEM COMPONENTS
 - * CIRCULATION PUMP
 - * DRAIN MOTOR/PUMP
 - * FILL VALVE
 - * LOWER WASH ARM
 - * TUBE TO UPPER WASH ARM
 - * UPPER WASH ARM
- * 25 YEAR LIMITED WARRANTY-STAINLESS STEEL TANK OR INNER DOOR LINER WHICH DEVELOPS A WATER LEAK

TRASH COMPACTORS

- * 90 DAYS-PAINTED OR DECORATIVE ITEMS
- * 1 YEAR FULL WARRANTY-COMPONENTS AND ACCESSORIES
- * 5 YEAR LIMITED WARRANTY-DRIVE SYSTEM MOTOR

DISPOSERS

- * VCFW 1020 AND VBFW
- * 7 YEAR FULL WARRANTY
- * VCHW 1000 AND VBHW 1030
- * 5 YEAR FULL WARRANTY

Product Warranty (continued)

REFRIGERATION PRODUCTS

REFRIGERATION

- * 90 DAYS-PAINTED OR DECORATIVE ITEMS
- * 2 YEARS FULL WARRANTY
- * 6 YEARS FULL WARRANTY ON SEALED

SYSTEM

COMPONENTS

- * COMPRESSOR
- * CONDENSER
- * DRYER/STRAINER
- * EVAPORATOR
- * CONNECTING TUBING
- * 12 YEAR LIMITED WARRANTY-SEALED

SYSTEM

COMPONENT (PARTS ONLY)

- * COMPRESSOR
- * CONDENSER
- * DRYER/STRAINER
- * EVAPORATOR
- * CONNECTING TUBING

ICE MAKER

- * 90 DAYS-PAINTED OF DECORATIVE ITEMS\
- * 2 YEAR FULL WARRANTY
- * 6 YEAR FULL WARRANTY ON SEALED

SYSTEM

COMPONENT

- * COMPRESSOR
- * CONDENSER
- * DRYER/STRAINER
- * EVAPORATOR
- * CONNECTING TUBING
- * 12 YEAR LIMITED WARRANTY-SEALED

SYSTEM

COMPONENT (PART ONLY)

- * COMPRESSOR
- * CONDENSER
- * DRYER/STRAINER
- * EVAPORATOR
- * CONNECTING TUBING

WINE COOLER

- * 90 DAYS-PAINTED OR DECORATIVE ITEMS
- * 2 YEAR FULL WARRANTY
- * 6 YEAR FULL WARRANTY ON SEALED

SYSTEM

COMPONENT

- * COMPRESSOR
- * CONDENSER
- * DRYER/STRAINER
- * EVAPORATOR
- * CONNECTING TUBING
- * 12 YEAR LIMITED WARRANTY-SEALED

SYSTEM

COMPONENT (PART ONLY)

- * COMPRESSOR
- * CONDENSER
- * DRYER/STRAINER
- * EVAPORATOR
- * CONNECTING TUBING

OUTDOOR PRODUCTS

GAS GRILLS

- * 90 DAY-PAINTED, PORCELAIN, AND

DECORATIVE

ITEMS

- * 1 YEAR FULL WARRANTY
- * 5 YEAR LIMITED WARRANTY-CAST IRON BURNER ASSEMBLIES, INFRARED ROTISSERIE

BURNERS,

AND PORCELAIN GRILL GRATES

- * LIFETIME WARRANTY-STAINLESS STEEL

PART

WHICH RUST THROUGH

PROXIMITY TO SIDE CABINET INSTALLATION

1. Range / Range tops may be installed directly adjacent to existing 36" high base cabinets. **IMPORTANT**-the top grate support **MUST** be 3/8" above the adjacent base cabinet countertop. This may be accomplished by raising the unit, (using the adjustment spindles on the range legs) or (using shims for the range top).
2. The range / range top **CANNOT** be installed directly adjacent to sidewalls, tall cabinets, tall appliances, or other side vertical surfaces above 36" high. There must be a minimum of 6" side clearance from the range to such combustible surfaces above the 36" counter height.
3. Within the 6" side clearance to combustible vertical surfaces above 36", the maximum wall cabinet depth must be 13" and wall cabinets within this 6" side clearance must be 18" above the 36" high countertop.
4. Wall cabinets above the range / range top must be a minimum of 36" above the cooking surface for the full width of the range / range top.

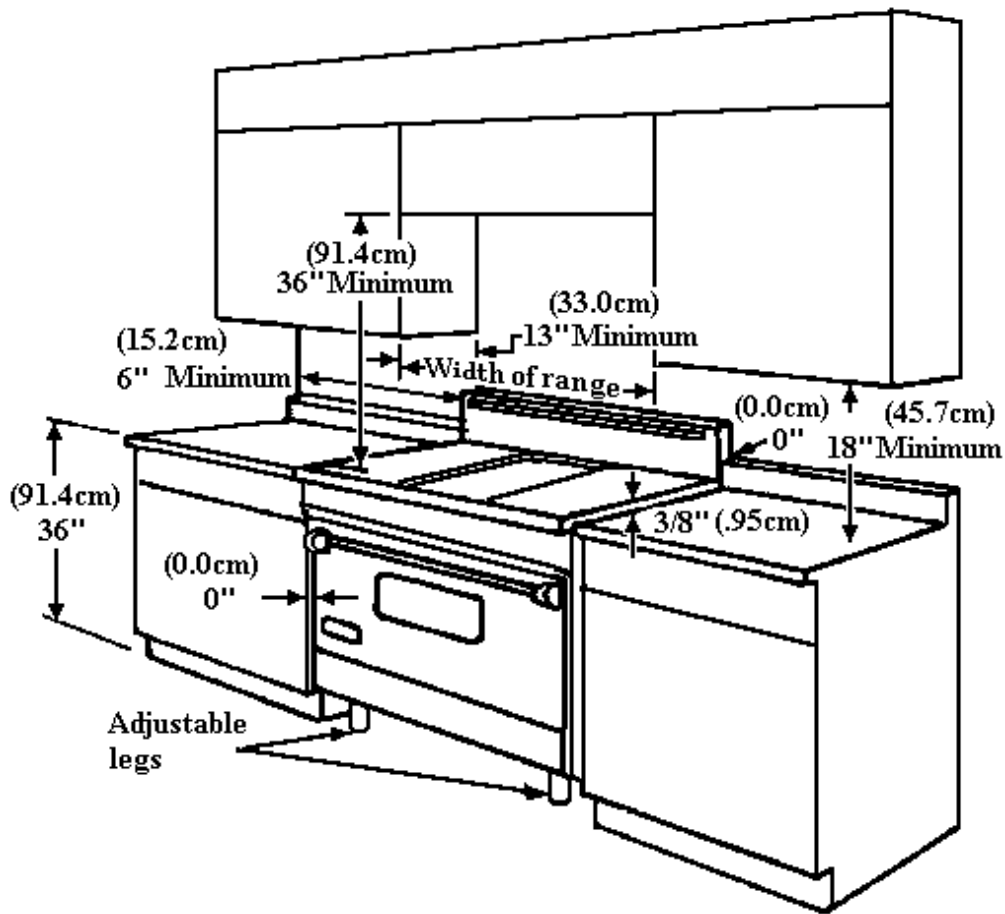

	30" W Models	36" W Models	48" W Models	60" W Models
Overall Width	29 7/8" (75.9cm)	35 7/8" (91.1cm)	47 7/8" (121.6cm)	59 1/2" (151.1cm)

WOOD/COMPOSITE OVERLAY INSTALLATION

The bottom of the hood should be no less than 27" (68.6cm) above the grates. It is more desirable for the bottom of the hood to be 29 5/8" to 35 5/8" above the grates. This would typically result in the bottom of the hood being 66" (167.6cm) to 72" (182.9cm) above the floor. The bottom of the hood should never be more than 72" (182.9cm) above the floor or more than 35 5/8" (90.5cm) above the grates. These dimensions provide for safe and efficient operation of the hood.

WALL INSTALLATION

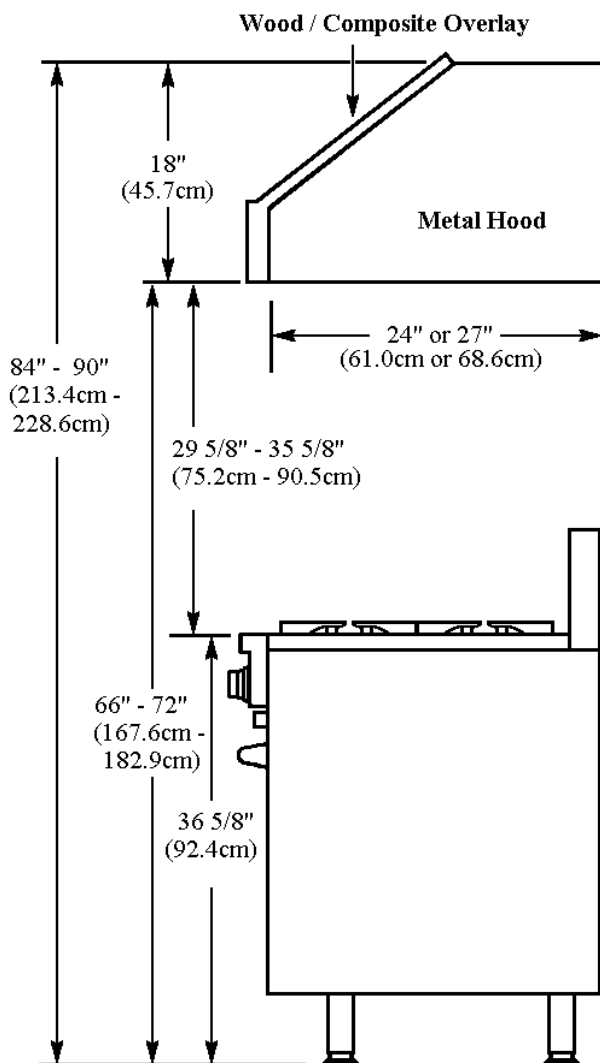

ISLAND INSTALLATION

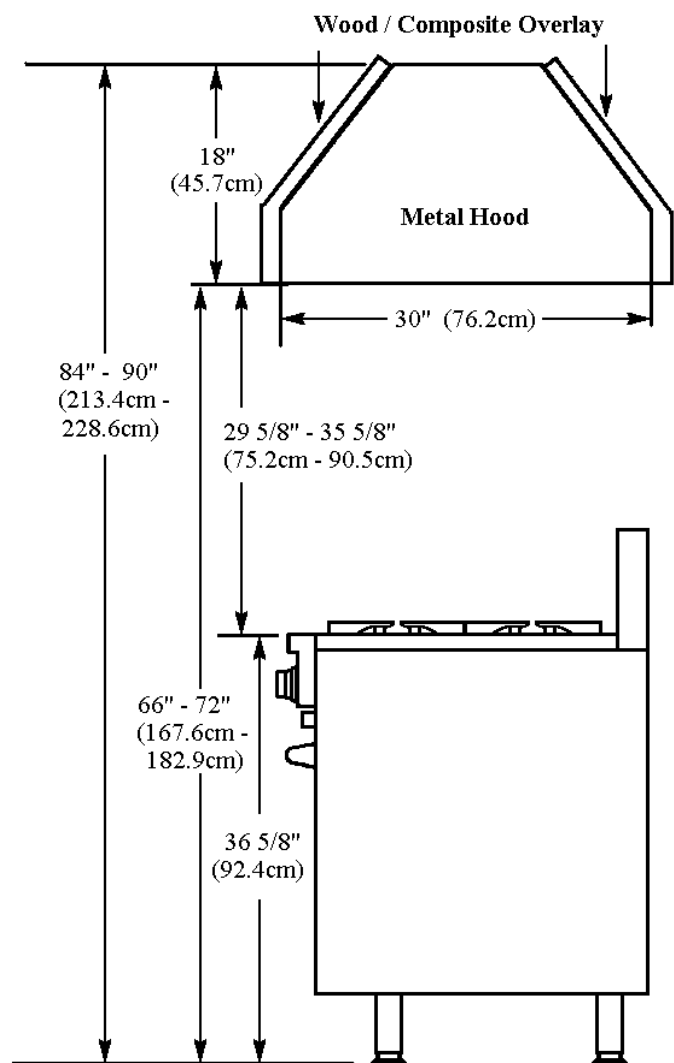

COMPONENTS (WITH COLOR CODED WIRIES)

CONTROL CIRCUIT BOARD (P.C. BOARD) DUAL FUEL SELF-CLEAN FREE-STANDING RANGES WITH SEALED BURNERS

Function: The Door Lock Control / Timer is activated by the line voltage at the "SEL" (1) contact. Relay "RL1" (2) and "RL2" (3) close providing voltage to the Door Lock Motor. The Relays stay closed until 10 seconds after sensor #3 (4) receives a signal that the Door Lock is fully closed. Once this happens Relay "RL2" (3) opens to stop the Door Lock Motor. Relay "RL1" (1) stays closed providing voltage to the Auto Reset thermostat. Relays "RL3" and "RL4" close powering the Cooling Fan Motor and Cycle Relay. "RL3" and "RL4" will stay closed for 3 ½ hours unless power is interrupted to sensor #3 (4) or SEL (1). In which case "RL3" and "RL4" will open, interrupting the clean cycle and Cooling Fan, and "RL2" (3) will close, opening the Door Lock. "RL2" (3) will stay closed until 2 seconds after sensor #4 (5) is powered.

AUTO RESET SWITCH: DUAL FUEL SELF-CLEAN FREESTANDING RANGES WITH SEALED BURNERS

Function: The Auto Reset Switch is a single pole / double throw switch (thermostat) which is activated by a thermo-bulb and lever which is calibrated to 575* F plus / minus 25* F. **Clean door lock below 575* F.** The Door Lock Motor is energized through the Auto Reset Switch (thermostat) contacts 2 - 1. **Clean door lock above 575* F.** Auto Reset Switch (thermostat) switches to contacts 1 -3 turning on the Door Lock indicator Light and disables the Door Lock Motor circuit. **Final below 575* F.** Auto Reset Switch (thermostat) switches to contacts 1 -2, turning off the Door Lock Motor circuit through door Lock Motor / Timer Relay LS2 - M1. Door Lock Motor operates until 2 seconds after sensor 4 is signaled by VC that the Door Lock switch SW1 has been closed mechanically by the door lock bolt. The Door Lock / Timer switches LS2 - M1 and LS1-L1 open and the timer resets.

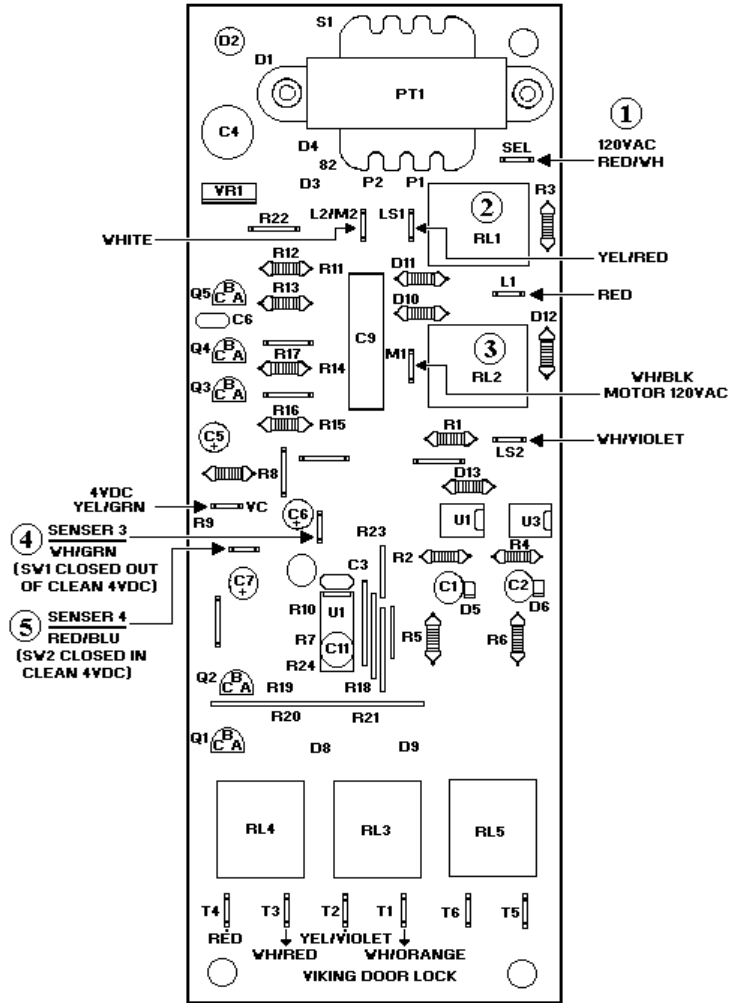

CONTROL CIRCUIT BOARD

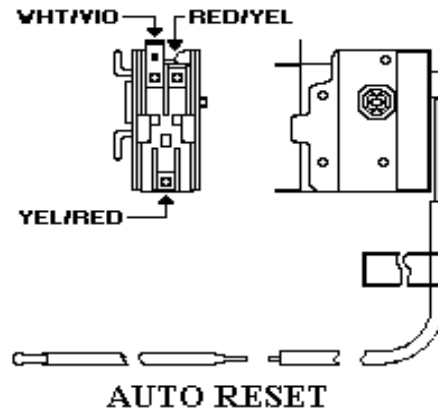

AUTO RESET

HIGH LIMIT SWITCH: DUAL FUEL SELF-CLEAN FREE-STANDING RANGES WITH SEALED BURNERS

Function: The Switch has a ½ “ bi-metal disc. The two metals have different thermal coefficients of expansion which cause the disc to bow as it heats up. When it reaches the calibration temperature the disc snaps open, which opens the electrical contacts. The Switch opens when temperature reaches 275°F plus or minus 9°F and will close when temperatures are 248° F plus or minus 9°F.

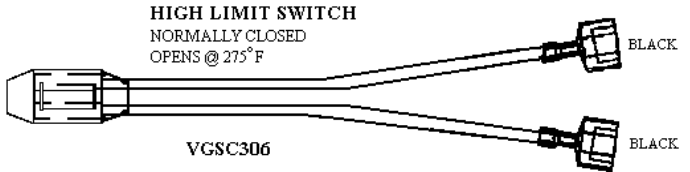
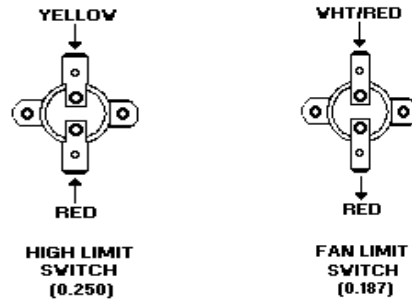

COOLING FAN LIMIT SWITCH: DUAL FUEL SELF-CLEAN FREE-STANDING RANGES WITH SEALED BURNERS

Function: The Switch has a ½ “ bi-metal disc. The two metals have different thermal coefficients of expansion which cause the disc to bow as it heats up. When it reaches the calibration temperature the disc snaps closed, which closes the electrical contacts. The Switch closes when temperatures reach 230°F plus or minus 9°F and will open when temperatures are below 203°F plus or minus 9°F.

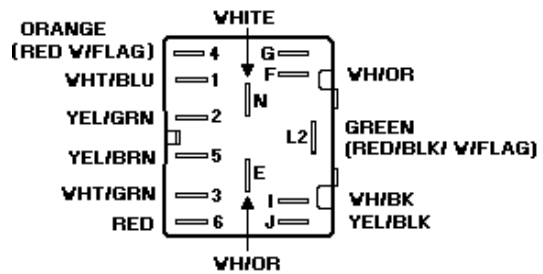

SELECTOR SWITCH (8 POS)

SELECTOR SWITCH (8 POS) (PJ030001)

Function: Rotating the shaft twists a cam which moves one or more spring loaded levers, which make contact with a terminal closing the circuit.

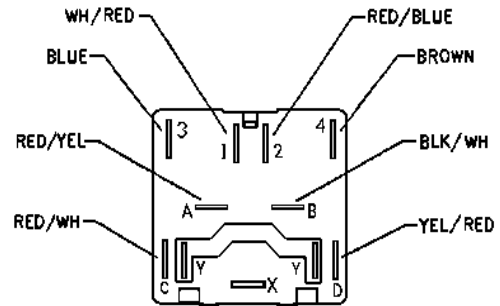

SELECTOR SWITCH (PJ030009) VDSC485(LH)

SELECTOR SWITCH (3 POS)

SELECTOR SWITCH (3 POS) (PJ030010)

OVEN THERMOSTAT

Function: As the shaft is rotated from the OFF position clockwise, an internal cam pushes a lever, which increases the temperature at which the thermostat cycles. Rotating the shaft 212° (angle °) switches an external (clean) Micro Switch to the closed position.

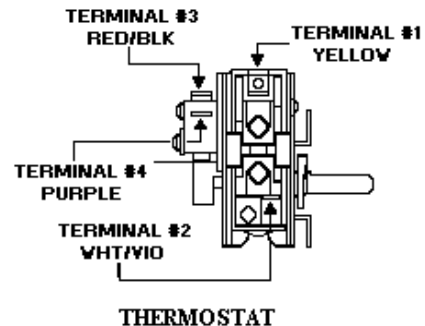

COMPONENTS (continued)

DOOR LOCK MOTOR:DUAL FUEL SELF-CLEAN FREESTANDING RANGES WITH SEALED BURNERS'

Function: When the Door Lock Motor is powered it turned a cam which pulls back a lever. As the lever moves back it allows a micro switch (SW1) to open. When the lever reaches the fully closed position it closes a double stacked micro switch (SW2 & SW3). **Door lock switch SW2** completes the circuit to sensor #3 on the Door Lock Control/timer board. After 10 seconds LS1-M1 opens, stopping the Door Lock motion. **Door Lock Switch #3** closes T1-T2 and T3-T4 energizing Power Relay #1 and the Cooling Fan. Closing Power Relay contacts supplies 240 VAC to both Broil Elements and 120 VAC to the Bake Element.

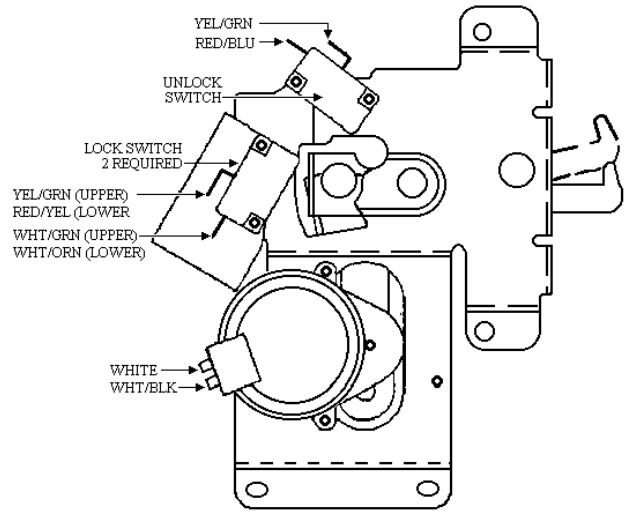

POWER RELAY #1 (PM010129): DUAL FUEL SELF-CLEAN FREESTANDING RANGES WITH SEALED BURNERS

Function: Relay #1 (power) supplies power to the Bake and Broil Elements.

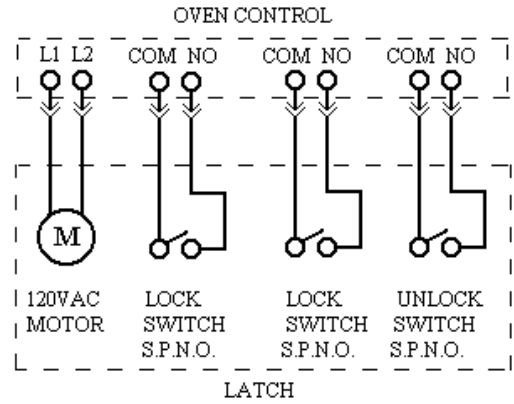

RELAY #2 - #3 - #5 - #6

VEDO205 (PM010020)

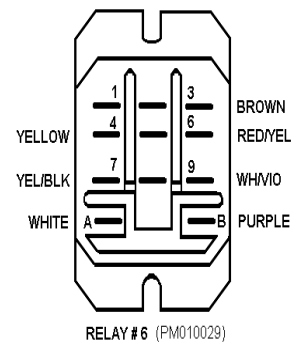
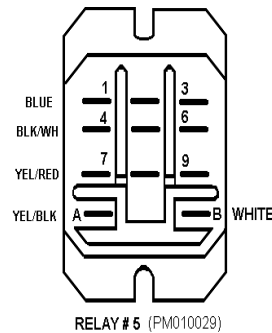
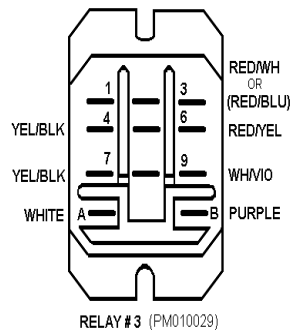
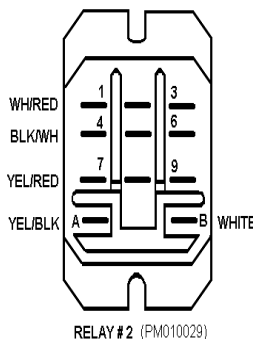
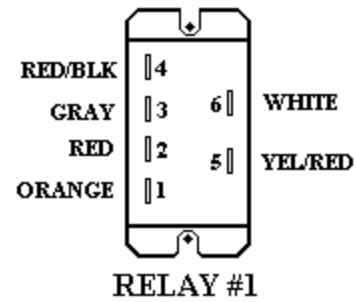

COMPONENTS (continued)

RELAY #2 – #3 - #5 (PM010025): DUAL FUEL SELF-CLEAN FREE- STANDING RANGES WITH SEALED BURNERS.

Function: Setting the selector switch to clean closes the Heating Element circuits 4-F, 1-N, 2-L2, 3-L2 and Door Lock Module / Timer circuit J-6, energizing Relay #2. The thermostat cycling contacts 1 to 2 and the clean switch contacts 3 to 4 close energizing Relay #3. Relay #3 allows circuit J-6 to turn on the Clean Indicator Light and enable the Door Lock Module / Timer to close Relays LS1-L1 and LS2 - M1. This powers the Door Lock Motor until 10 seconds after Sensor 3 is signaled by VC that Door Lock Switch SW2 has been closed mechanically (along with SW3) by the Door Lock Bolt.

RELAY #4 (PM010129)
VDSC485 (LH)

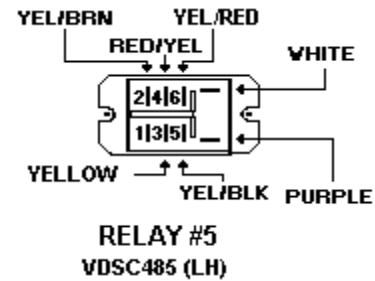
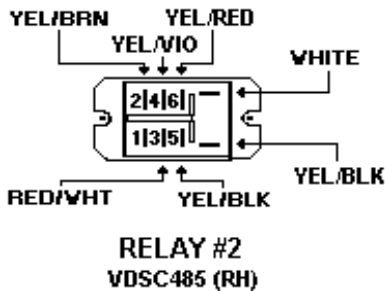
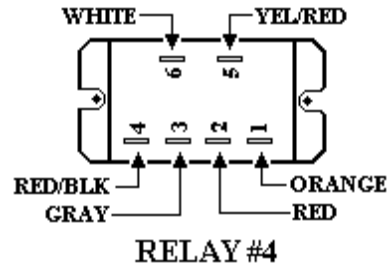
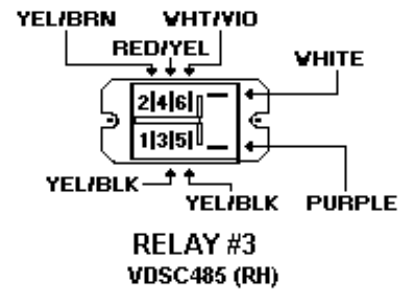
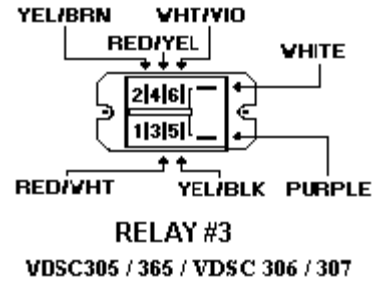
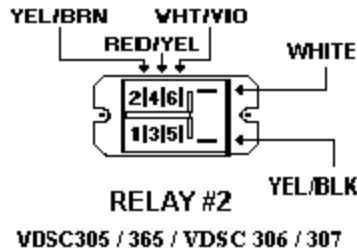

COMPONENTS (continued)

CONVECTION FAN MOTOR:DUAL FUEL
SELF-CLEAN FREE STANDING RANGES WITH
SEALED BURNERS

Function: Provides an even flow of air
in the oven cavity for more even
baking.

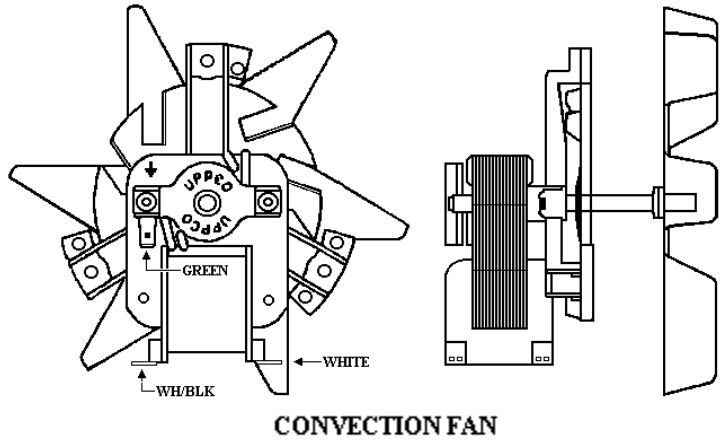

COOLING FAN MOTOR

Function: Provides a continuous supply
of cool air during self clean cycles to
keep the Door Lock Motor and
associated circuits cool.

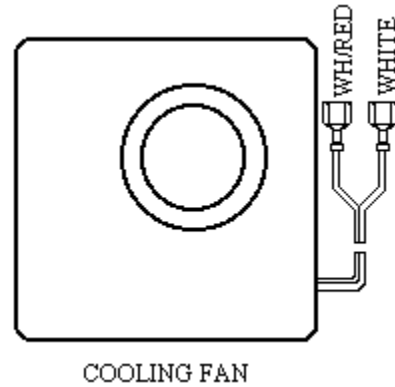

OVEN LIGHT

Function: Provides interior oven light for
viewing baking products.

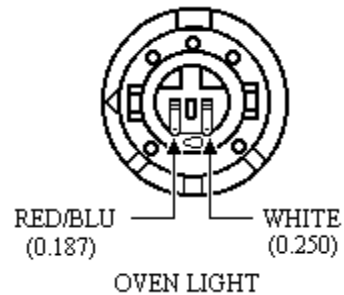

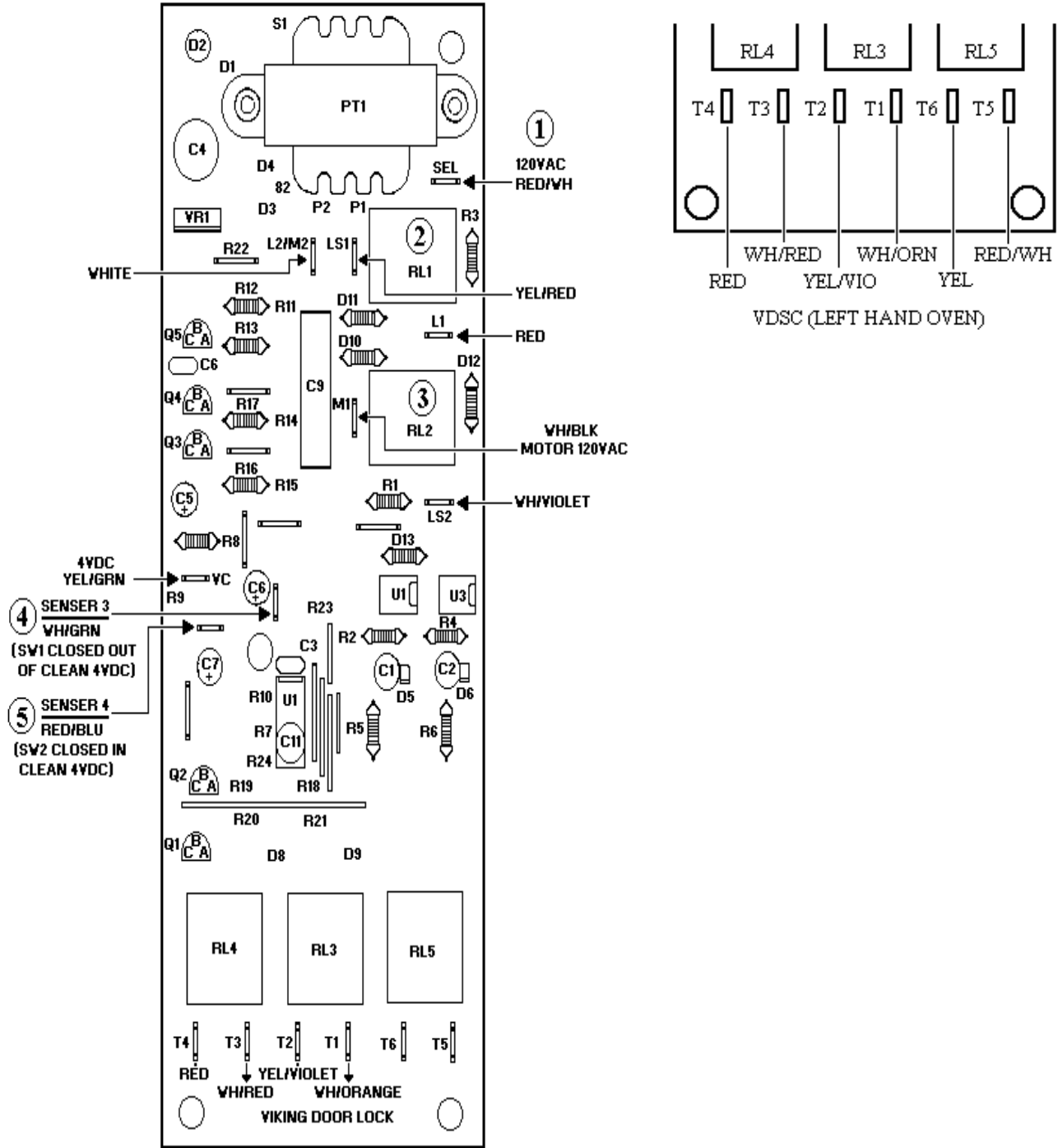

P.C. CONTROL BOARD WIRING FOR RELAYS T4 – T3 – T2 – T1 – T6 – T5





CONTROL CIRCUIT BOARD

VOLTAGE READINGS

MEASURED WITH DOOR OPEN

		
T4	107VAC	70VAC
T3	4VAC	16VAC
T2	4VAC	16VAC
T1	5VAC	1VAC

MEASURED WITH DOOR LOCKED

T4	80VAC	56VAC	
T3	85VAC	56VAC	
T2	90VAC	56VAC	
T1	93VAC	56VAC	

VC--4VDC

SENSOR 3--3VDC SW2 closed in self clean (Locked). 

SENSOR 4--4VDC SW1 closed with clean lock open. 

M1--120VAC lock motor supply voltage.
(31VAC in locked position)

LS2--70VAC (unlocked)--**55VAC** (locked)

L1-- 70VAC (unlocked)--**56VAC** (locked) 

L2/M2--16VAC(unlocked)--**32VAC**
(locked)

LS1--107VAC (locked or unlocked)

SEL--120VAC SUPPLY

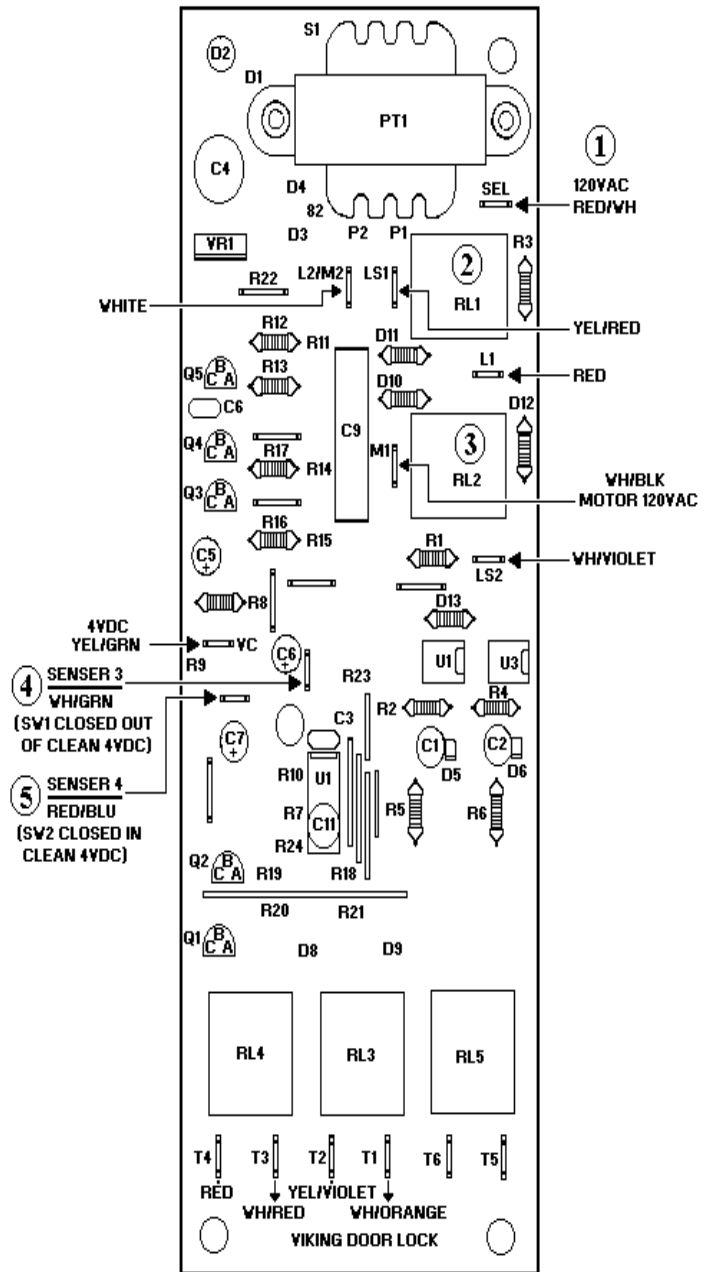
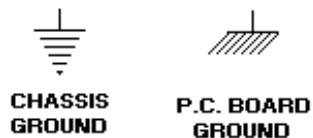

CONTROL CIRCUIT BOARD

8 POSITION SELECTORSWITCH (With shaft position and internal connections)

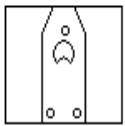
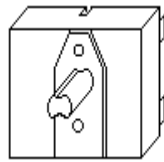
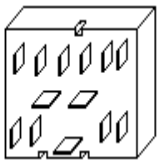

OFF

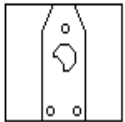
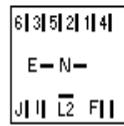

BAKE

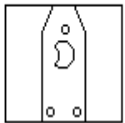
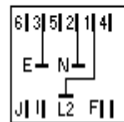

CONVECTION
BAKE

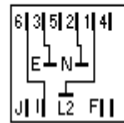

CONVECTION
COOK

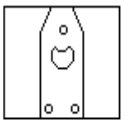

BROIL

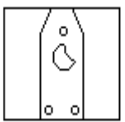

MAXI
BROIL

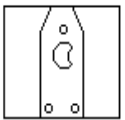
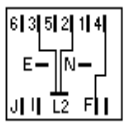

CONVECTION
BROIL

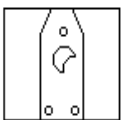
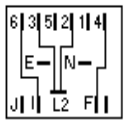

SELF
CLEAN

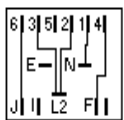

SELF CLEAN

Selector Switch closes Heating Element contacts 4-F, 1-N, 2-L2, 3-L2, and Door Lock Module / Timer contacts J-6 energizing Relay #1.

Thermostat Clean Position closes Thermostat cycling contacts 1-2 and normally open (N) - common (C) energizing Relay #3.

Relay # 3 turns on the Clean indicator Light and energizes Door Lock Module / Timer (PC Board) relays LS1-L1 and LS2-M1, also supplying 120VAC to SEL on the PC board

Relays LS1 and LS2 turns the Door Lock Motor on through the Auto Reset Thermostat contacts 2-1.

Door Lock Motor rotates opening SW1 and closing SW2 and SW3.

Door Lock Switch #2 completes the circuit to sensor #3 on the PC board. After 10 seconds LS1-M1 opens, stopping the Door Lock motion.

Door Lock Switch #3 closes T1-T2 and T3-T4 energizing Power Relay #1 and the Cooling Fan. Closing Power Relay #1's contacts supplies 240VAC to both Broil Elements and 120VAC to the Bake Element.

CLEAN DOOR LOCK ABOVE 575°F ± 25°F

Auto Reset Thermostat switches to contacts 1-3 turning on the Door Lock indicator Light and disables the Door Lock Motor circuit.

CLEAN TEMPERATURE (875°F) REACHED.

Door Lock Module / Timer opens T3 -T-4 and T1-T2 turning off the Cooling Fan, now powered by the Fan Limit Switch when needed, and opens the circuit to the Power Relay #1 disabling the Heating Elements.

FINAL BELOW 575°F ± 25°F

Auto Reset Thermostat switches to contacts 1-2. turning off the Door Lock Motor circuit through Door Lock Motor / Timer Relay LS2-M-1. Door Lock Motor operates until 2 seconds after sensor 4 is signaled by VC that the Door Lock /Timer switches LS2- M1 and LS1-L1 open and the Timer reset.

OVEN TEMPERATURE CALIBRATION

DUAL FUEL RANGES SELF-CLEAN FREESTANDING RANGES WITH SEALED BURNERS

Electric oven calibration using the EATON thermostat. The adjustment screw is located on the bottom of the thermostat (3/32 Allen head screw). Each 1/4 turn is equal to approximately 35 degrees. **COUNTER CLOCKWISE** adjustment will **DECREASE** the temperature. **CLOCKWISE** adjustment will **INCREASE** the temperature.

If the oven temperature is off more than 50 degrees you should replace the thermostat.

REMEMBER WHEN YOU CHANGE THE OVEN TEMPERATURE YOU ARE ALSO CHANGING THE SELF-CLEAN TEMPERATURE. (As a rule of thumb you should only calibrate the thermostat to increase the oven temperature.)

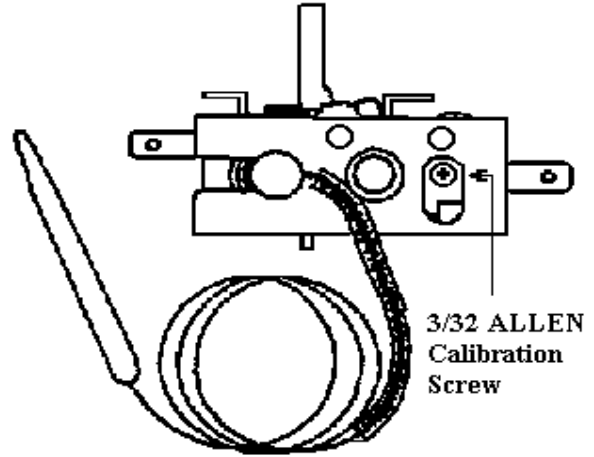

- A. **Center Oven Temperature Check:** Before turning the oven on, check the thermostat sensor bulb position. It should be straight, no kinks and secured in the mounting clips.
- B. Place the oven rack in the center of the oven.
- C. Place a loaded thermocouple lead in the center of the rack and close the door. Avoid touching metal with the thermocouple junction.
- D. Set the selector switch to “BAKE” and the temperature dial to 350°F.

NOTE: Do not overshoot the 350°F mark. When you go beyond 350°F, return the control to the lowest setting and reset to 350°F.

- E. Cycle the oven 5 times; Average the 3rd, 4th, and 5th cycles. The temperature is acceptable if the average is 350°F ± 25 °.

TEMPERATURE: CONVENTIONAL OVEN

CYCLE	1	2	3	4	5	AVERAGE
HIGH	(XX)	(XX)	()	()	()	()
LOW	(XX)	(XX)	()	()	()	()

- F. For convection test lower the oven temperature to 325°F. Preheat the oven with convection fan on.

TEMPERATURE; CONVECTION OVEN

CYCLE	1	2	3	AVERAGE
HIGH	(XX)	()	()	()
LOW	(XX)	()	()	()

- G. On conventional baking place pans in the center of the oven.
- H. On convection baking place pans on rack positions 2 and 4.
- I. Uneven temperatures left to right in the oven:
 1. Check air shutter adjustment: sharp blue flame, no yellow tipping.
 2. Check orifice hood adjustment.

DUAL FUEL SELF-CLEAN FREESTANDING RANGES WITH SEALED BURNERS

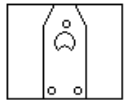
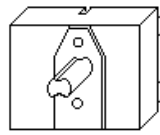
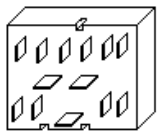
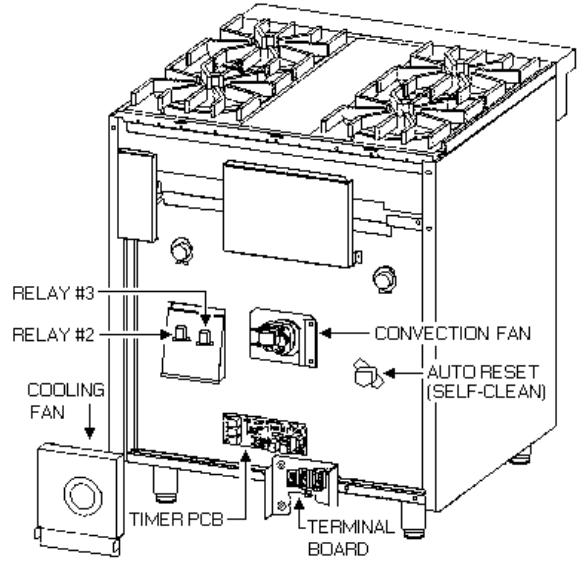
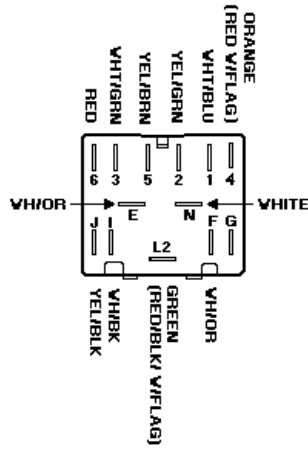

OFF

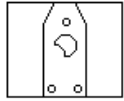
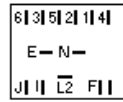

BAKE

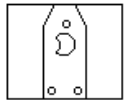
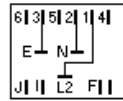

CONVECTION
BAKE

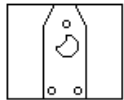
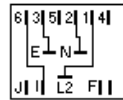

CONVECTION
COOK

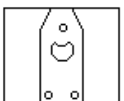
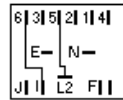

BROIL

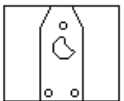
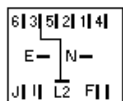

MAXI
BROIL

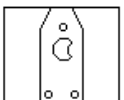
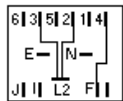

CONVECTION
BROIL

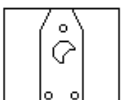
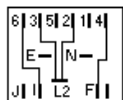

SELF
CLEAN

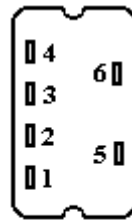
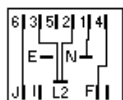

RELAY #1
RELAY #4

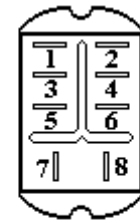

RELAY #2

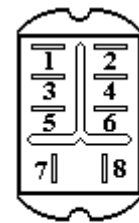

RELAY #3

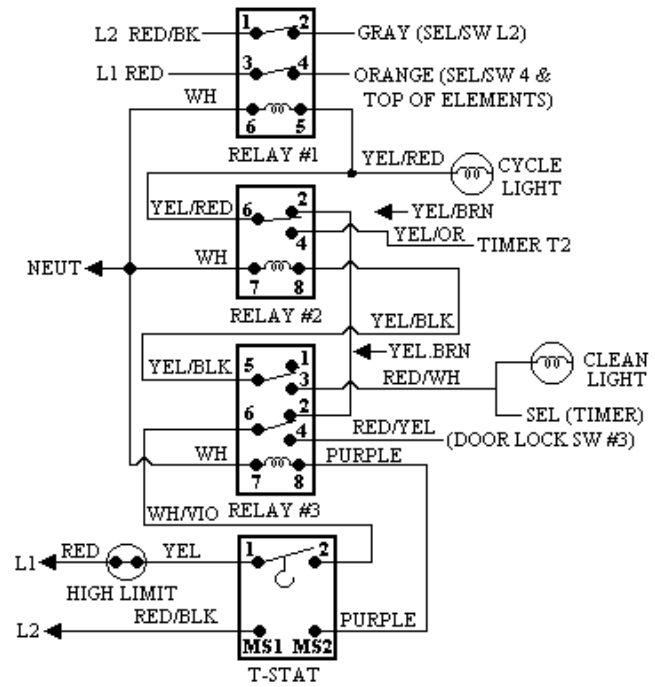

DUAL FUEL SELF-CLEAN FREESTANDING RANGES WITH SEALED BURNERS

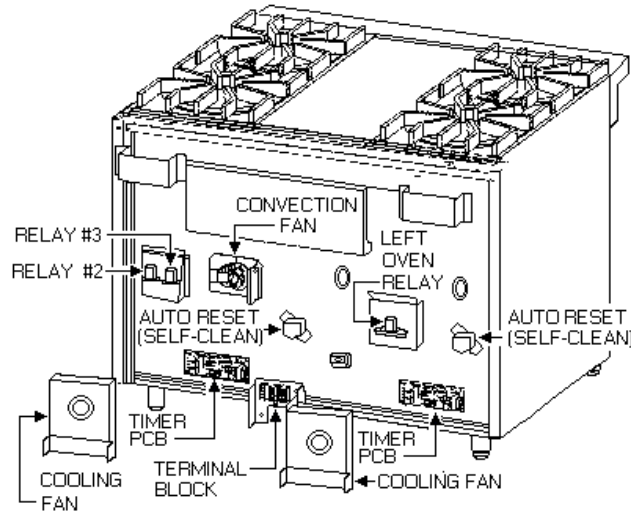

VDSC485 DUEL FUEL
Relay location and wiring connection

RIGHT HAND OVEN

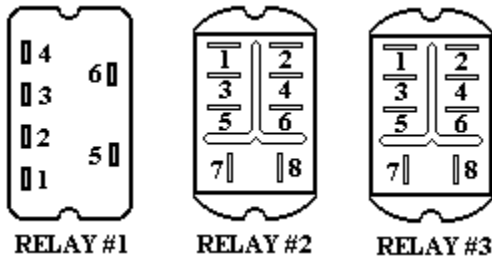

LEFT HAND

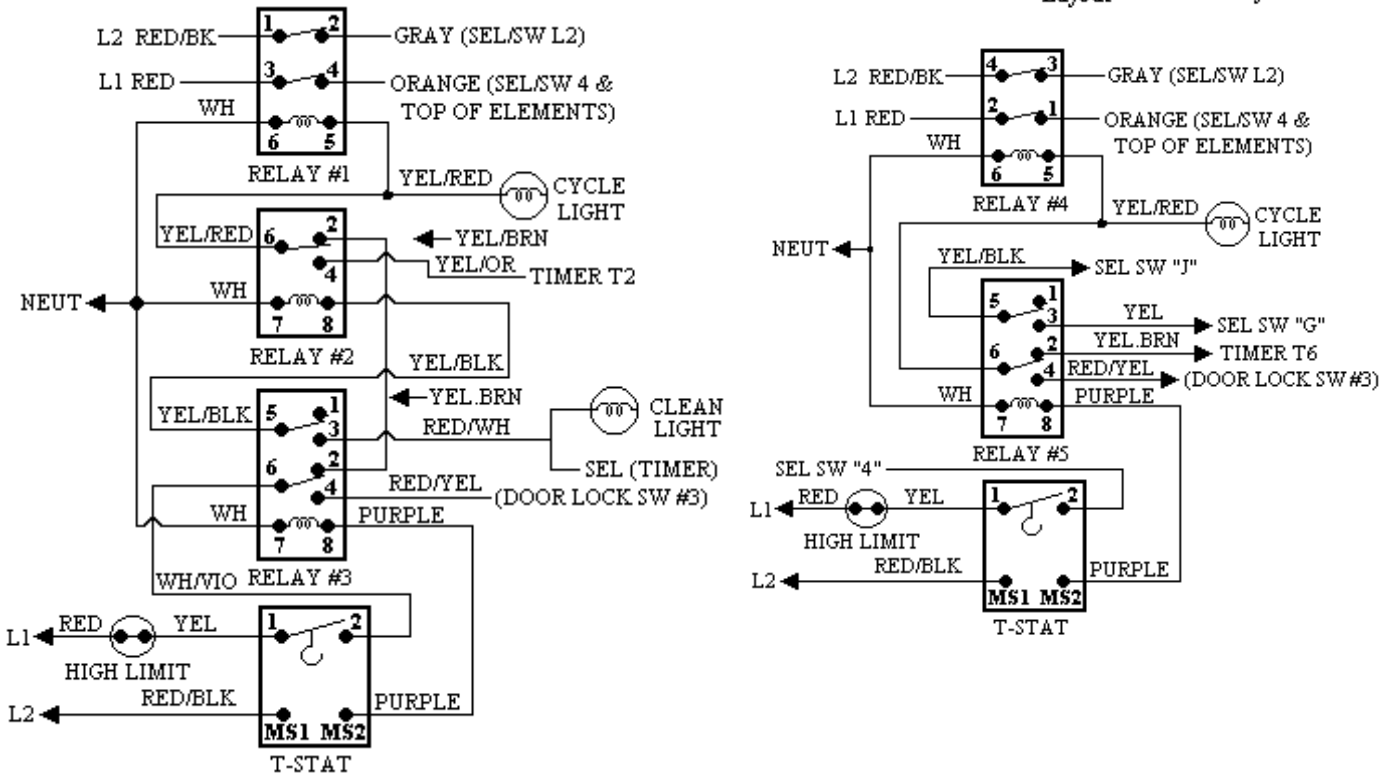
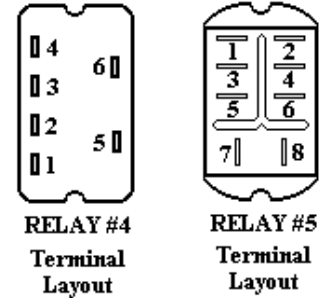

VOLTAGE and RESISTANCE READINGS

BAKE ELEMENT:

“A” to “B” 21.1 Ohms

“A” to “B” 240VAC during Bake and Convection Bake.

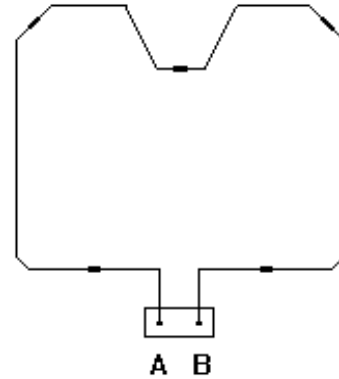

BROIL ELEMENT:

“A” to “D” (outside element) 32.6 Ohms

“A” to “D” 50VAC during Bake and Convection Bake.
240VAC during Maxi Broil.
240VAC during Convection Broil
240VAC during Self-clean

“B” to “C” (inside element) 45.2 Ohms

“B” to “C” 70VAC during Bake and Convection Bake.
240VAC during Mini Broil
240VAC during Maxi Broil
240VAC during Convection Broil
240VAC during Self-clean

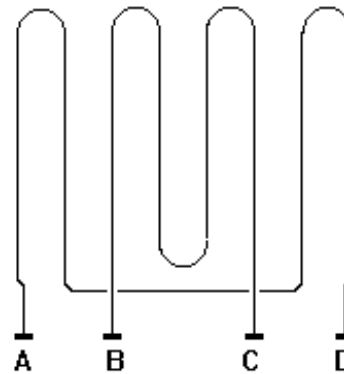

CONVECTION ELEMENT:

“A” to “B” 26 Ohms

“A” to “B” 240VAC during Convection Cook

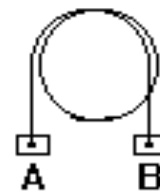

WIRING DIAGRAM DUAL FUEL 30" W. & 36" W. CONVECTION RANGES

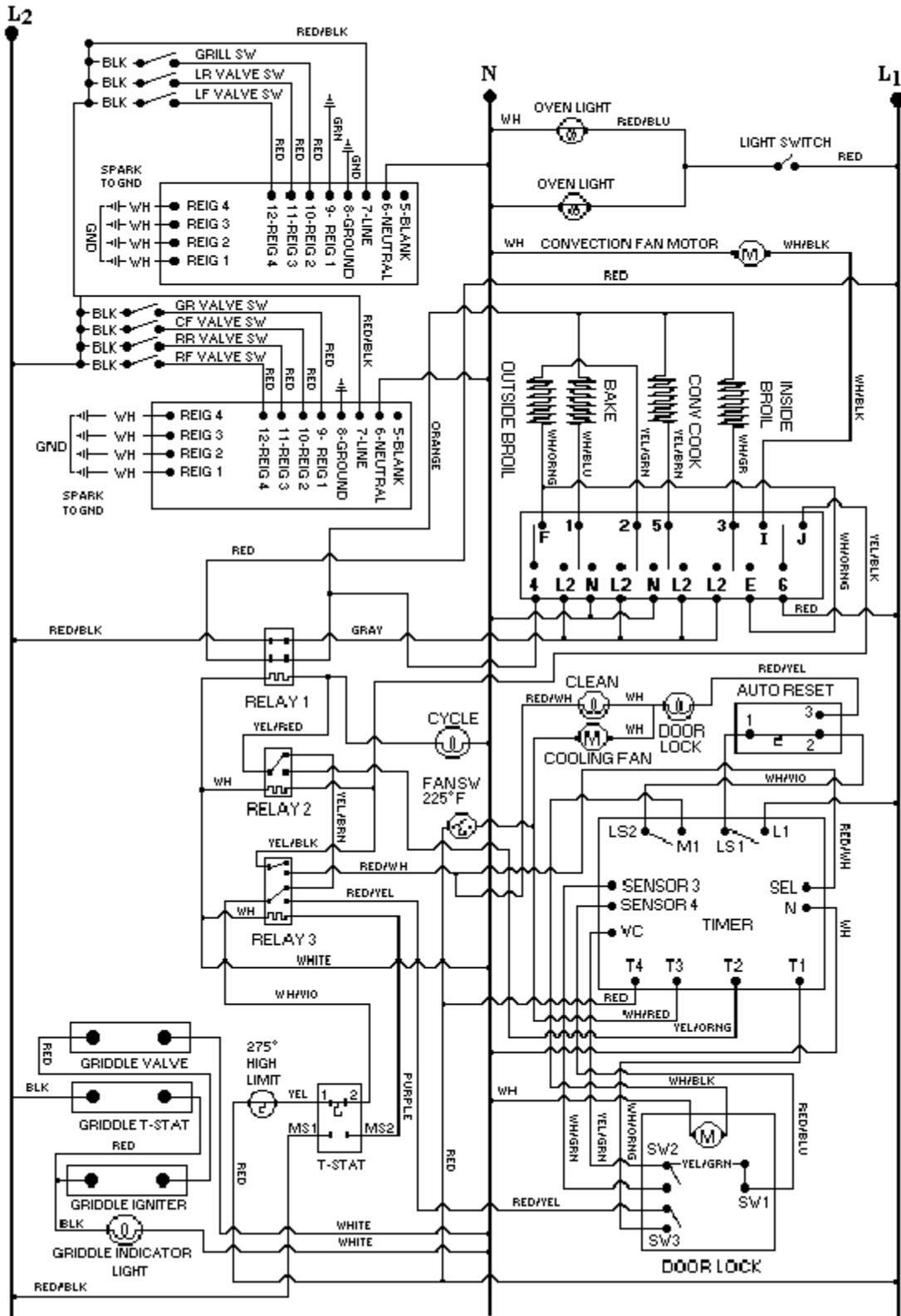

WIRING DIAGRAM
DUAL FUEL SELF-CLEAN FREESTANDING RANGES
WITH SEALED BURNERS

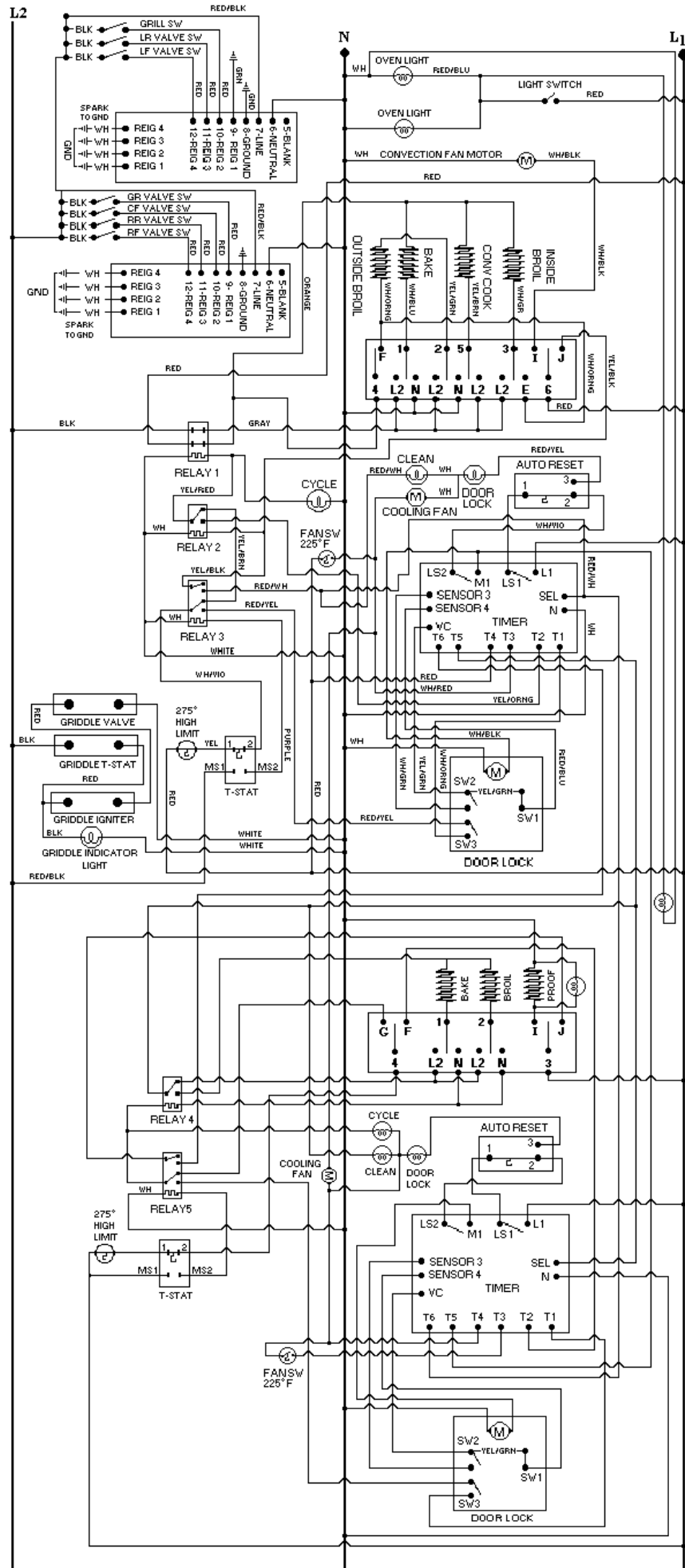

BREAKOUT DIAGRAMS FOR EACH FUNCTION

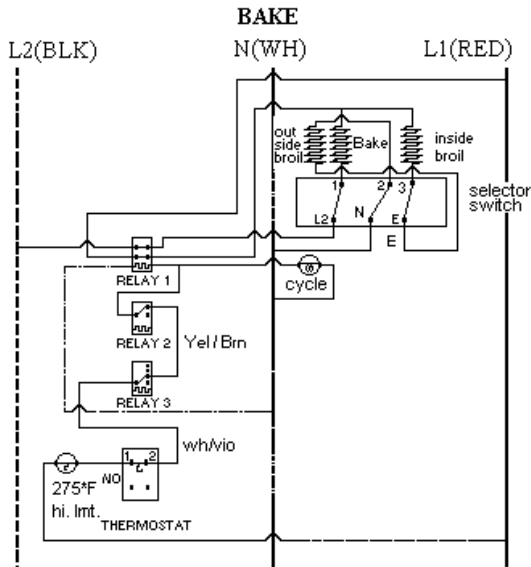

SELECT BAKE, position closes switches 1-L2, 2-N, and 3-E. The Thermostat closes Switches Cy1-Cy2, which cycles with oven Temperature powering Relay 1 and the Oven Cycle Light. When Relay 1 closes, it powers the Bake Element at 208/240VAC, and with the Broil Element in series across a 120VAC circuit it powers the inside Broil Element at 70VAC and the outside Broil Element at 50VAC.

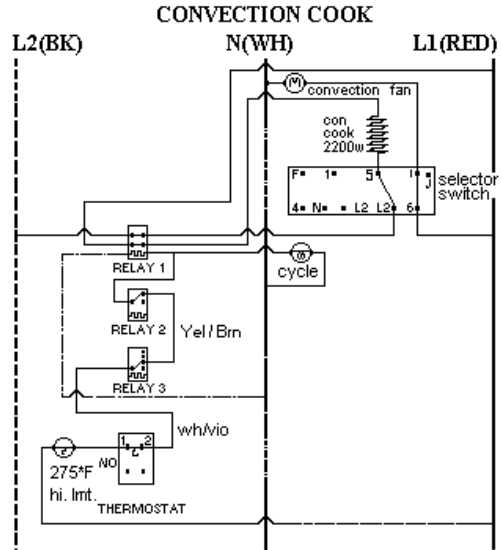

SELECT CONVECTION COOK position closes Switches 5-L2 and 6-L1. 6-L1 powers the Convection Fan through L1 at 120VAC. The thermostat closes Switch Cy1-Cy2, which cycles the Oven temperature, powering relay #1 and the Oven Cycle Light. When Relay #1 closes, it powers the Convection Element at 208/240VAC

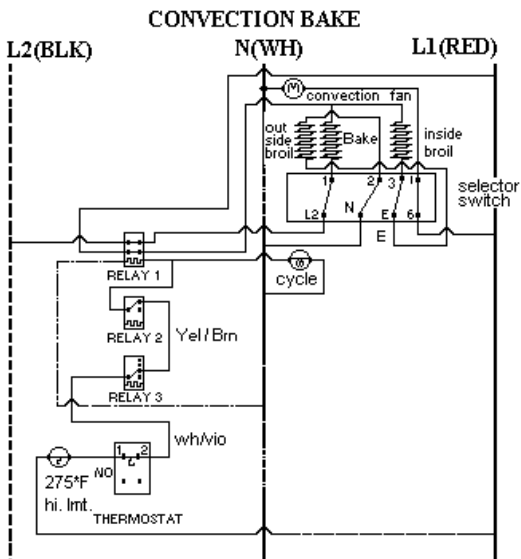

SELECT CONVECTION BAKE position closes Switches 1-L2, 2-N, 3-E, and 6-L1. 6-L1 powers the Convection Fan through L1 at 120VAC. The Thermostat closes Switches Cy1-Cy2, which cycles with oven temperature powering Relay 1 and the Oven Cycle Light. When Relay 1 closes, it powers the Bake Element at 208/240VAC, and with the Broil Element in series across a 120VAC circuit, it powers the inside Broil Element at 760VAC and the outside Broil Element at 50VAC.

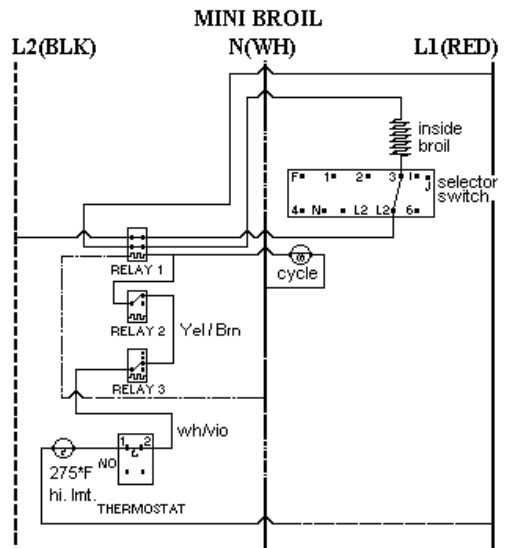

SELECT MINI BROIL position closes Switches 3-L2. The thermostat closes Switch Cy1-Cy2, powering Relay #1 and the Oven Cycle Light. When Relay #1 closes, it powers the inside Broil Element at 208/240VAC.

BREAKOUT DIAGRAMS FOR EACH FUNCTION

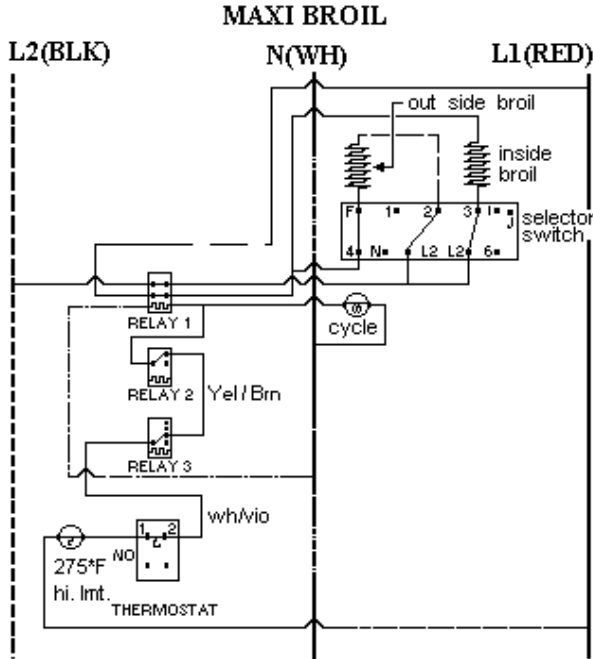

SELECT MAXI BROIL position closes Switches 4-F, 2-L2 and 3-L2. the thermostat closes Switch Cy1-Cy2, which cycles with the oven temperature, powering Relay #1 and the oven cycle light. When Relay #1 closes, it powers the inside broil element at 208/240 VAC and the outside broil element at 208/240 VAC.

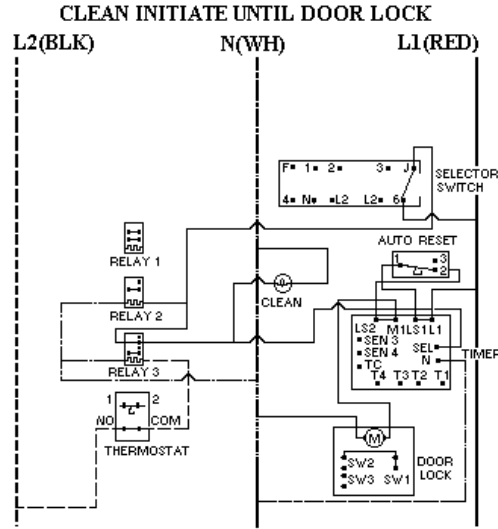

SELECT CLEAN position closes heating element circuits 4-F, 1-N, 2-L2, 3-L2 and door lock module / timer circuit J6 switches relay2. Thermostat clean position closes the cycle switch and thermostat clean switch, which switches relay 3. Switching relay 3 allows circuit J-6 to turn on the clean indicator light and enable the door lock module / timer which closes relay LS-L1 and LS2-M1. This powers the door lock motor until 10 seconds after sensor #3 is signaled by VC that the door lock switch SW2 has been closed mechanically (along with SW3) by the door lock bolt.

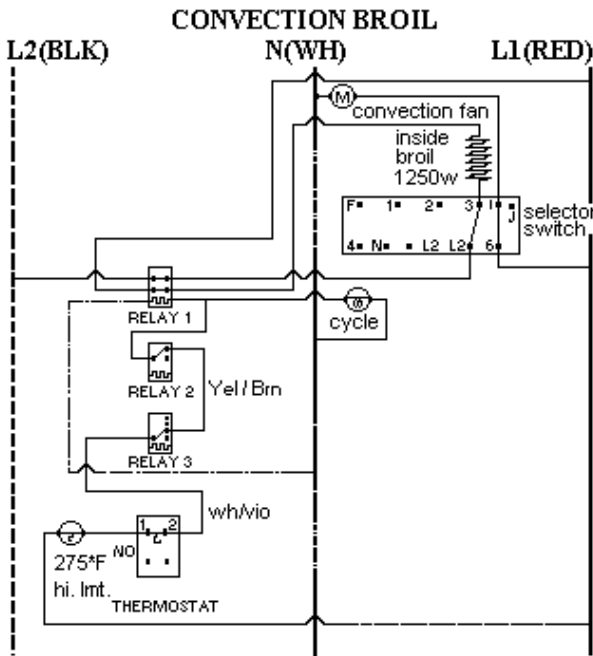

SELECT CONVECTION BROIL position closes switches 4 - F, 2 -L2, 3 - L2 and 6 - 1. 6-1 powers the convection fan through L1 at 120VAC. The thermostat closes switch Cy1 - Cy2, which cycles the oven temperature, powering relay 1 and the oven cycle light. When relay 2 closes it powers the inside broil element at 208/240VAC and the outside broil element at 208/240VAC.

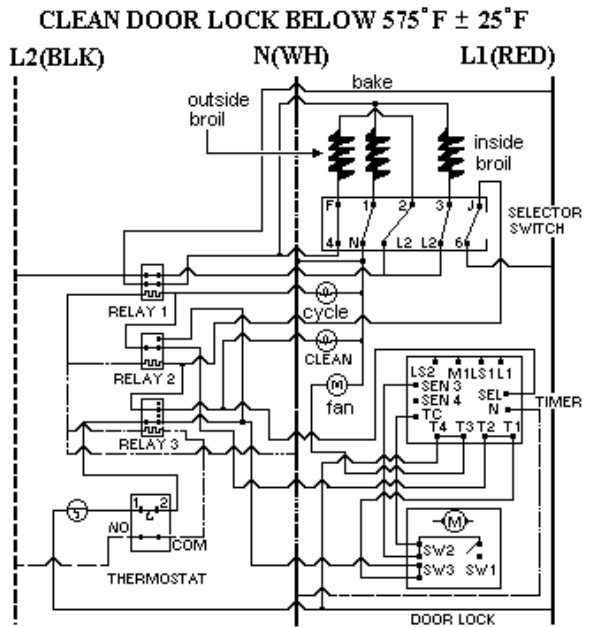

10 seconds after the signal to sensor #3, switch LS2 - M1 is opened, stopping the door lock motion and switches T1 - T2 and T3 - T4 which switches relay 1, powering the cooling fan, which closes relay 1 powering the inside and outside broil elements at 208/240VAC and the bake element to 120VAC.

BREAKOUT DIAGRAMS FOR EACH FUNCTION

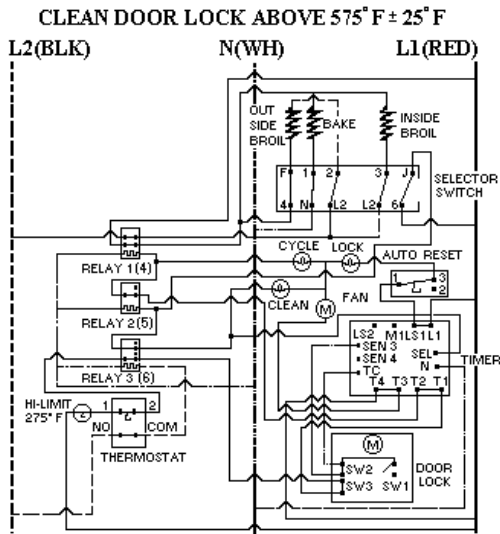

AUTO RESET switches to 1-3 which turns Door Lock Indicator light on and disables Door Lock Motor circuit.

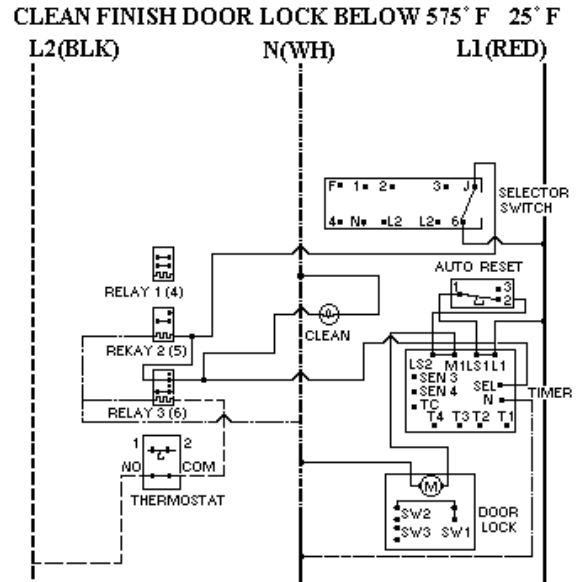

AUTO RESET Switches 1-2 closed allowing Door Lock Motor to operate and turning the Door Lock Light off. The Door lock Motor operates until 2 seconds after Sensor 4 is signaled by VC that the Door Lock SW1 has been closed mechanically by the Door Lock Bolt. The Door / Timer switches LS2-M1 and LS1-L1 open and the Timer resets.

CLEAN FINISH DOOR LOCK ABOVE 575° F ± 25° F

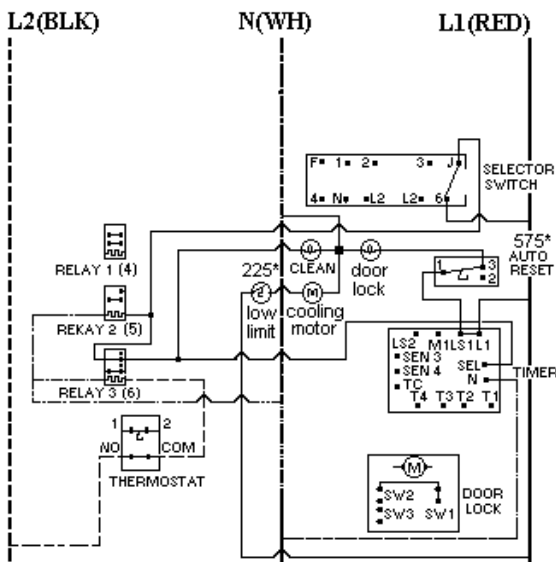

TIMER SWITCHES T3-T4, T1-T2 open, turning off the Cooling Fan which will then be powered at 120VAC by the Fan Limit Switch when needed, and opening the circuit to Relay # 1 which disables the Heating Elements. Switch LS2-M1 closes to power the Door Lock Motor.

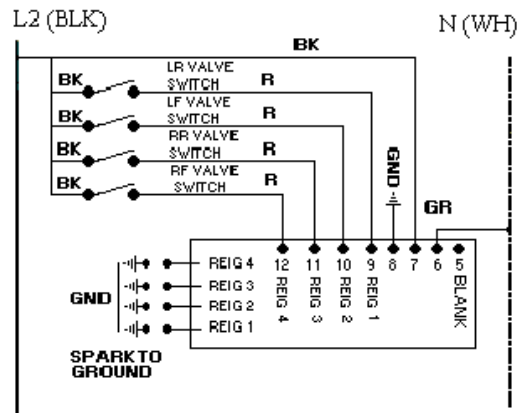

SURFACE BURNERS SPARK MODULE AND SPARK ELECTRODE CIRCUITS. (From L2 to Neutral).

ELECTRICAL CONNECTION

Use a 3 - wire power supply cord kit rated for 30 amps - 125/250 volts for Models VDSC and VERT or 50 amps - 240 volts for Model VESC with closed loop terminals and marked for use with ranges. Where local codes do not permit grounding through neutral, use a 4 - wire power supply cord. The cord or conduit must be secured to the range with the strain relief bracket. The electrical connection is made at the terminal block, which is located behind the access door on the back of the range.

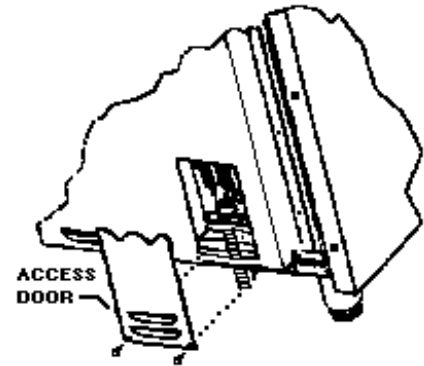

3 - Wire Power Supply Cord

1. Remove access door.
2. Remove supply cord strain relief bracket and 3 supply cord mounting screws on the terminal block.
3. Feed supply cord up through the hole in the bottom of range back.
4. Attach the line #1 (red) and line #2 (black) leads to the outside terminals and the neutral wire (white) to the center terminal on the terminal block.
5. Reattach supply cord strain relief bracket over supply cord, pushing supply cord up toward terminal block to relieve strain before tightening.
6. Reattach access door.

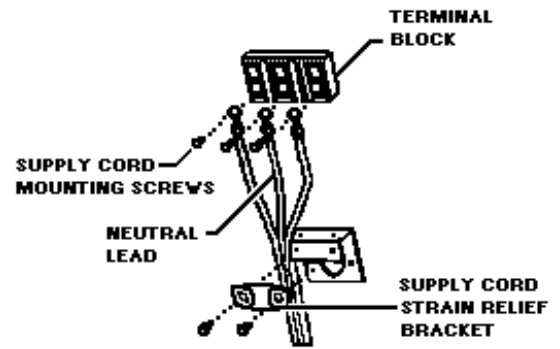

4 - Wire Power Supply Cord

1. Remove access door.
2. Remove supply cord strain relief bracket and 3 supply cord mounting screws on the terminal block.
3. Remove grounding screw; cut-off and discard ground strap.
4. Feed supply cord up through hole in the bottom of the range back.
5. Attach the ground lead (green) with the ground screw that was removed in step #3.
6. Attach the line #1 (red) and line #2 (black) leads to the outside terminals and the neutral wire (white) to the center terminal on the terminal block..
7. Reattach supply cord strain relief bracket over supply cord, pushing supply cord up towards terminal block to relieve strain before tightening.
8. Reattach access door.

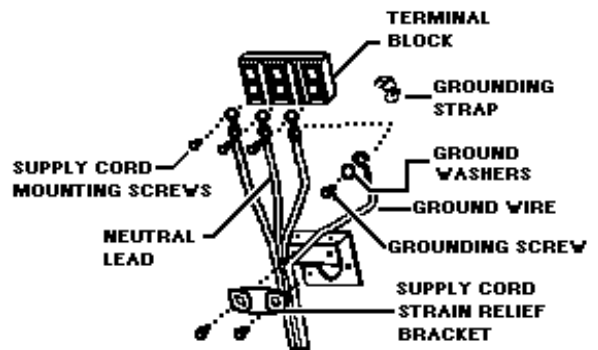

ELECTRICAL CONNECTIONS WITH CONDUIT

Use ½" trade size conduit with a conduit clamp, 12 AWG /600 volt copper conductor colored red for line # 1 and black for line # 2 and 14 AWG /600 volt copper conductor colored white for neutral with closed loop terminals marked for use with ranges. Where local codes do not permit grounding through neutral, use a green 12 AWG copper conductor as directed in the 4 - wire connector directions. The conduit must be secured to the range with the strain relief bracket. The electrical connection is made at the terminal block which is located behind the access door on the back of the range.

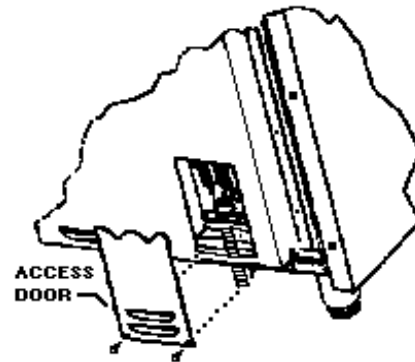

3 - Wire Power Connection

1. Remove access door.
2. Remove strain relief mounting angle and reattach as shown.
3. Feed ½" trade size conduit through the hole in the bottom of the range back and secure to the strain relief bracket with a conduit clamp.
4. Feed line #1 (red 12 AWG / 600v copper conductor), line #2 (black 12 AWG / 600v copper conductor), and neutral (white 14 AWG / 600v copper conductor) through conduit and attach closed loop terminals marked for use with ranges.
5. Remove 3 mounting screws and attach line #1 (red) to left terminal, line #2 (black) to the right terminal, and the neutral wire (white) to the center terminal.
6. Reattach the access door.

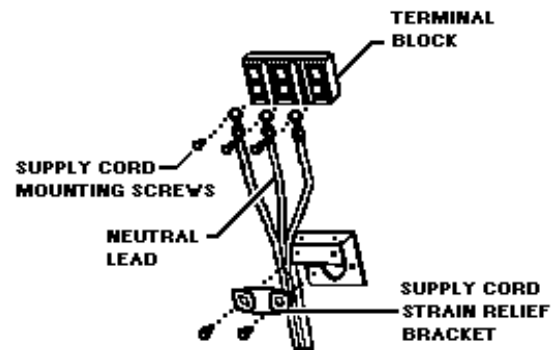

4 - Wire Power Connector

1. Remove access door.
2. Remove strain relief mounting angle and reattach as shown.
3. Feed 1½" trade size conduit through the hole in the bottom of the range back and secure to the strain relief bracket with a conduit clamp.
4. Feed line #1 (red 12 AWG / 600v copper conductor), line #2 (black 12 AWG / 600v copper conductor), neutral (white 14 AWG / 600v copper conductor), and a grounding wire (green 12 AWG copper conductor) through conduit and attach closed loop terminals marked for use with ranges. (Terminal is not required on grounding wire if used with ground washer).
5. Remove 3 mounting screws and green grounding screw. Cut-off and discard ground strap. Attach line #1 (red) to the left terminal, line #2 (black) to the right terminal, the neutral wire (white) to the center terminal and the copper ground wire to the green grounding screw using the ground washer.
6. Reattach the access door.

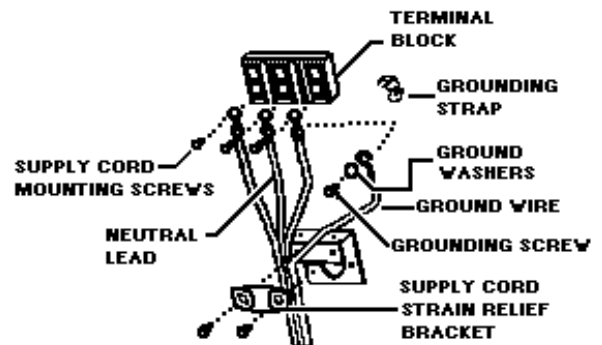

Natural to LP/Propane Conversion (For Sealed Burners)

This product is manufactured and adjusted for operation with natural gas as shipped from the factor. CAUTION: Before proceeding with conversion, turn off gas supply to the appliance and disconnect the electrical power.

To operate with LP/ Propane gas, the following adjustment should be made:

1. Remove the surface grates.
2. Remove the burner cap (item #1) and the burner head (item #2) by lifting up.
3. Remove the venturi (item #3).
4. Use a 5/16" (0.9cm) socket or nut driver to remove orifice (item #4) and replace it with LP orifices located next to the pressure regulator. Save the natural gas orifice for future use.
5. Replace the venturi (item #3) and hand tighten. Replace the burner head (item #2), the burner cap (item #1) and the surface grates.
6. To convert surface, griddle, and grill burners to LP/Propane, turn the burner orifice hoods clockwise until they become snug against the internal LP/Propane pin orifice.
7. A pressure regulator is located in the left rear corner of the burner box. Convert the regulator by removing the cap marked "Nat" and reverse it to read "LP". Be sure not to disturb or remove the spring beneath the cap.
8. Manifold pressure should be checked with a manometer. LP/Propane requires 10.0 W.C.P. Incoming line pressure upstream from the regulator must be 1" W.C.P. higher than the manifold pressure.

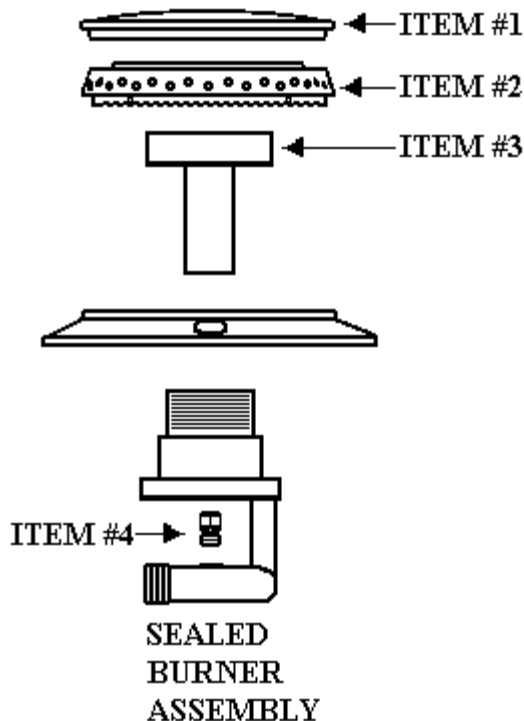

VDSC307 RANGETOP and SELF-CLEAN LOCK SERVICE

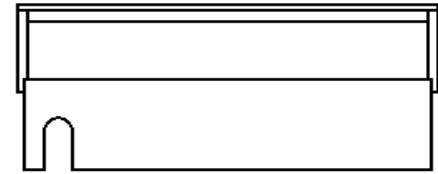
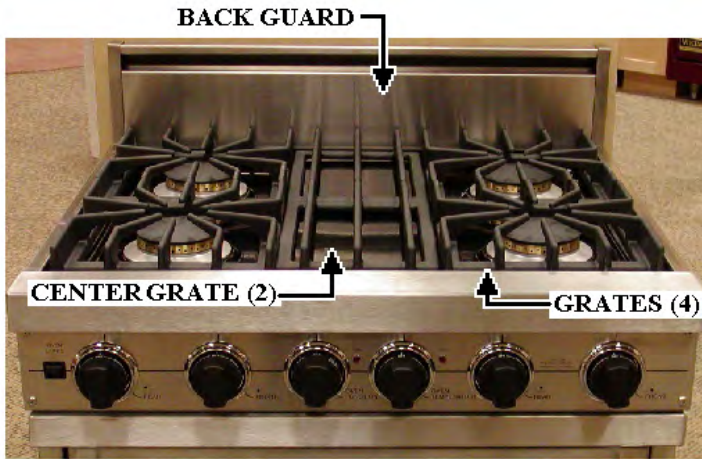

Backguard Assembly

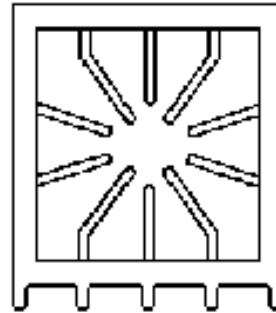

BURNER GRATE

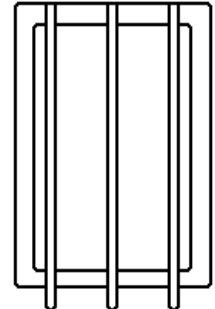

CENTER GRATE

1. Remove the Back guard, Grates (4), and the Center Grates (2).

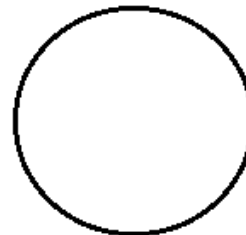
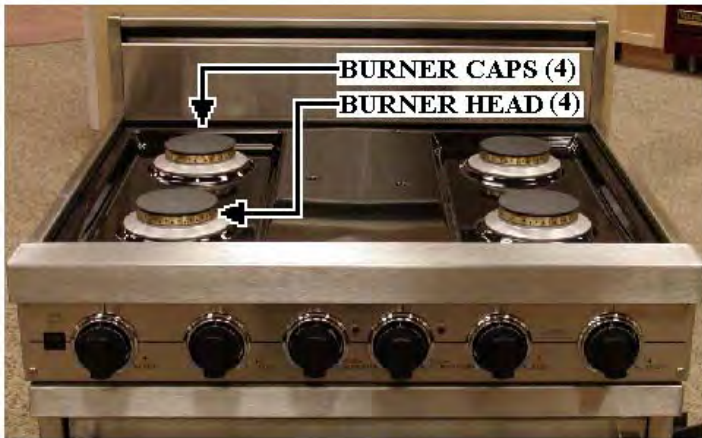

BURNER CAP

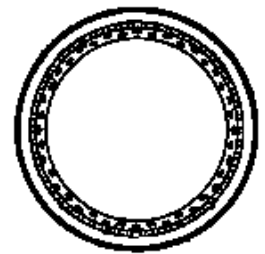

BURNER HEAD

2. Remove the Burner Caps (4) and Burner Heads (4) to gain access to the gas orifices. The unit is shipped from the factory with Natural Gas Orifices. The L.P. orifices are attached to the incoming gas line at the rear. The L.P. orifices are accessible before the backguard is installed.

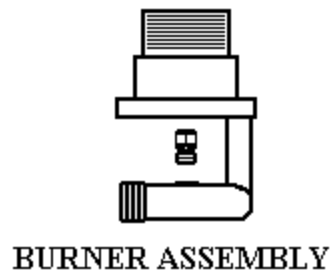
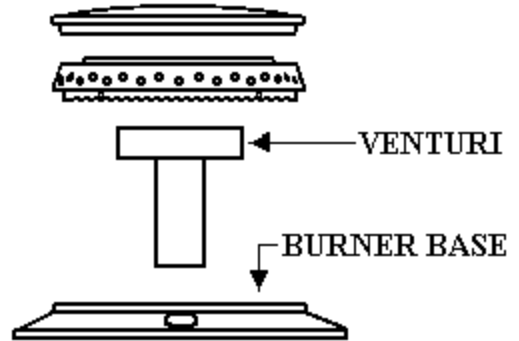

3. Remove the Brass venturi. To keep from scoring the brass venturi, wrap the jaws of a pair of channel locks with several turns of tape.

4. After removing the venturi the burner base can be lifted out of the main top. Disconnect the wire from the igniter. Lay the burner base aside taking care not to damage the customers property.

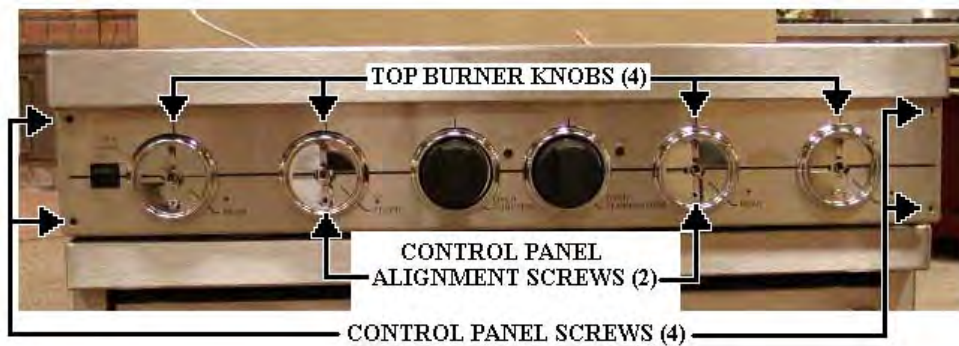

5. To remove the main top: a) remove the four (4) top burner knobs; b) remove the four screws holding the control panel in place; c) remove the two (2) bottom screws at the knob bezels second from either end. Lay the control panel down to rest on the restraining strap.

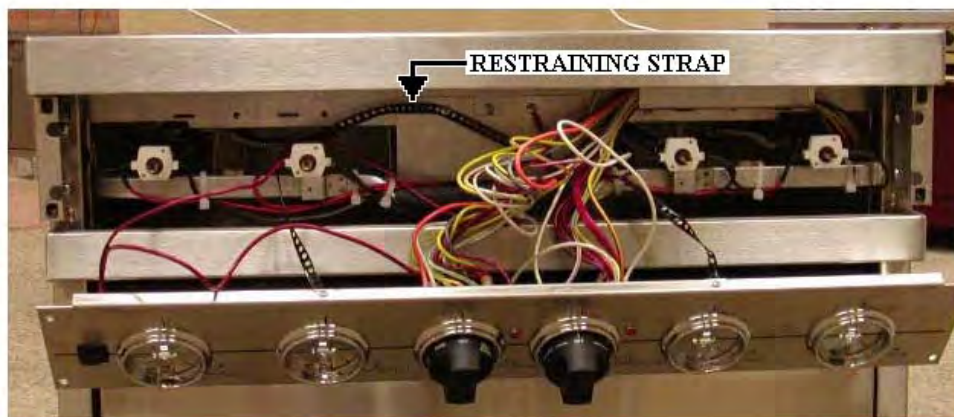

6. To replace or service the spark module remove the two screws (A) that secure the spark module support to the cover box. Do not remove the screw that is marked (B). The spark module support with the spark module can now be removed from the front after the control panel has been lowered.

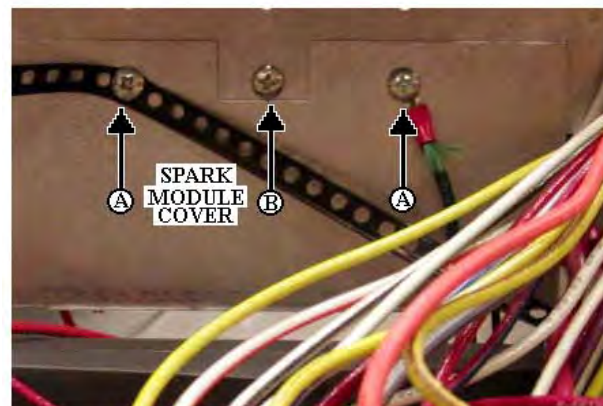
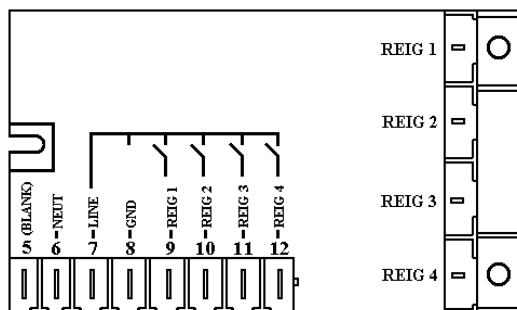

- Ⓐ SPARK MODULE COVER SCREWS
- Ⓑ SPARK MODULE COVER BOX SCREW

7. Remove the four (4) screws holding the landing ledge to the burner box. Lift the landing ledge up and lay aside.

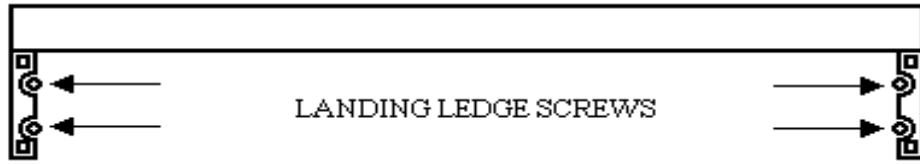

8. Once the landing ledge is removed the main top can now be removed. Lay aside for reassembling.

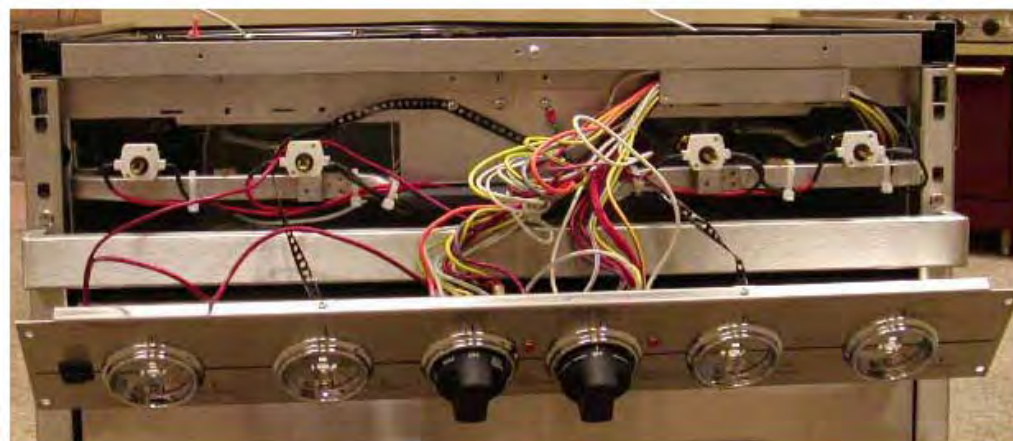

9. Components located beneath the main top are: Burner supports; Center support; Burner body supports; Main supports; Burner body; Orifice; Regulator; and Gas supply lines.

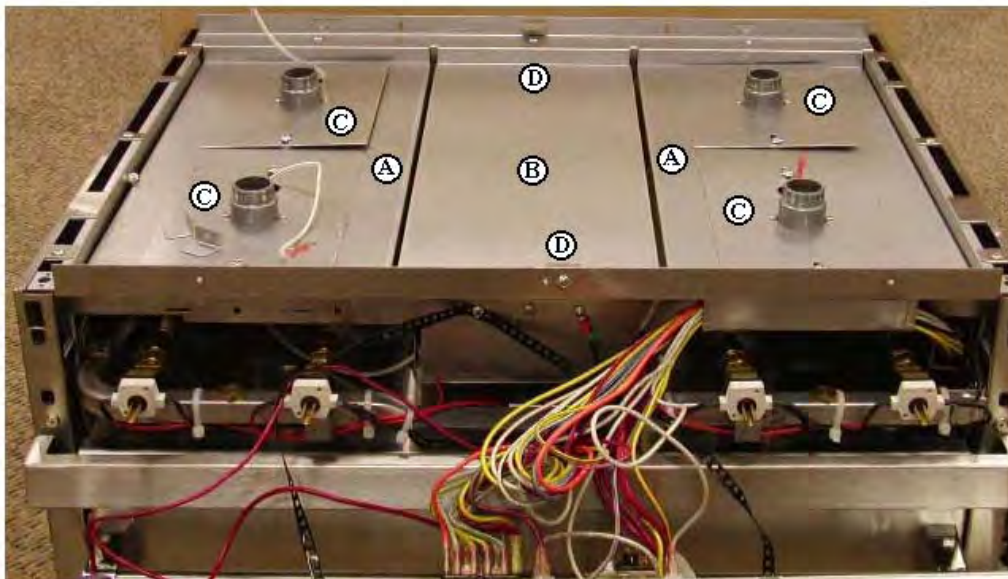
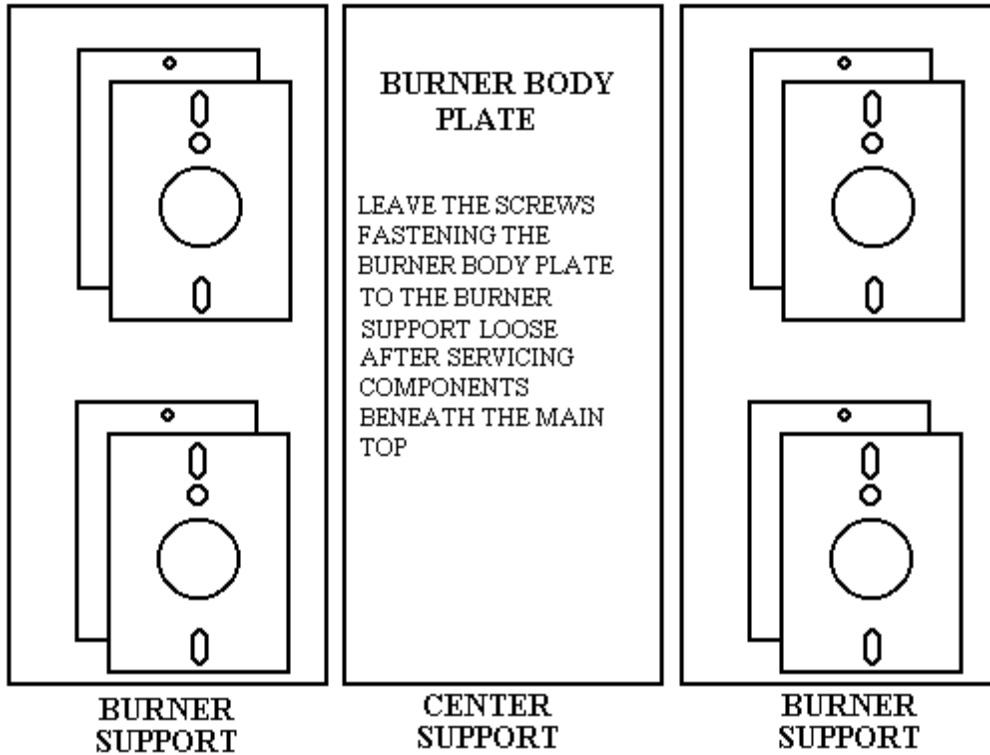

Ⓐ BURNER SUPPORTS (2) Ⓑ CENTER SUPPORT (1) Ⓒ BURNER BODY SUPPORTS(4) Ⓓ MAIN TOP SUPPORTS(2)

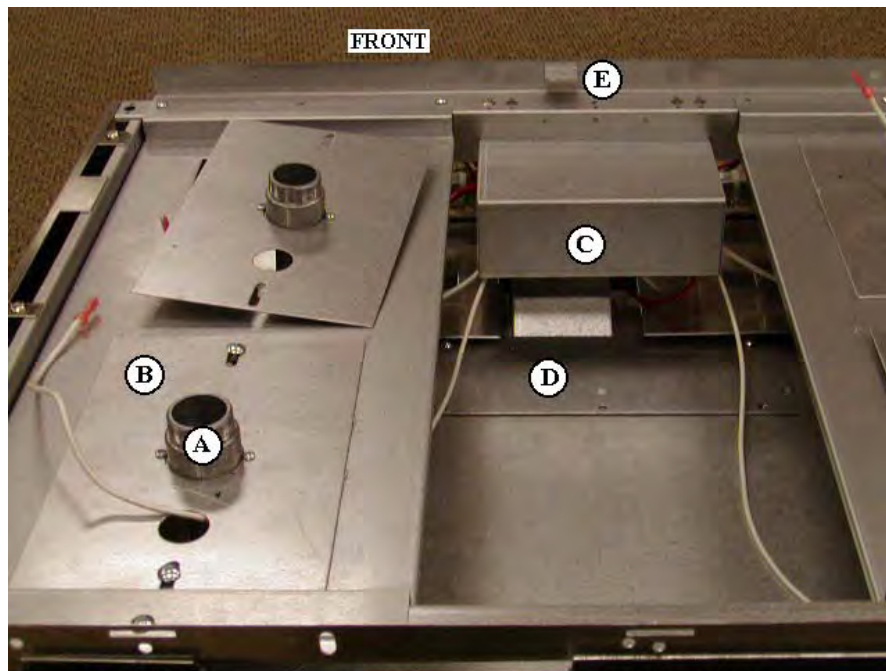

- (A) BURNER BODY
- (B) BURNER BODY PLATE
- (C) SPARK MODULE COVER
- (D) DOOR LOCK INSULATION BOX ASSY.
- (E) MAIN TOP SUPPORT

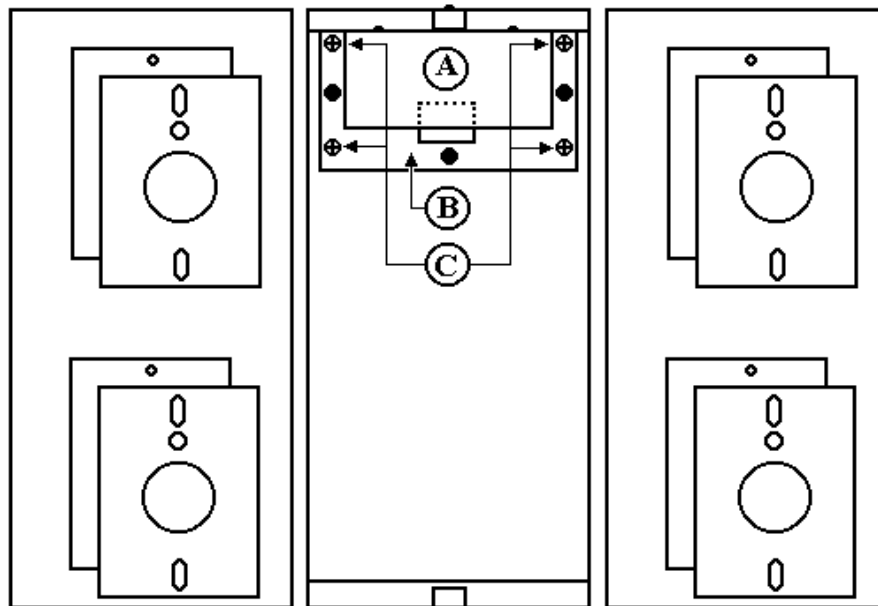

- (A) SPARK MODULE COVER
- (B) DOOR LOCK INSULATION BOX ASSY.

10. With the main top and center support removed you can access the door lock insulation box assembly. Remove the screws marked ©. Lift the door lock insulation assembly up and out to expose the self-clean latch and motor.

11. A street elbow has been added to the gas supply at the rear of the range to keep the flex line from having to bend over the edges of the back panel. Also a union has been added for easier access to install or replace the regulator.

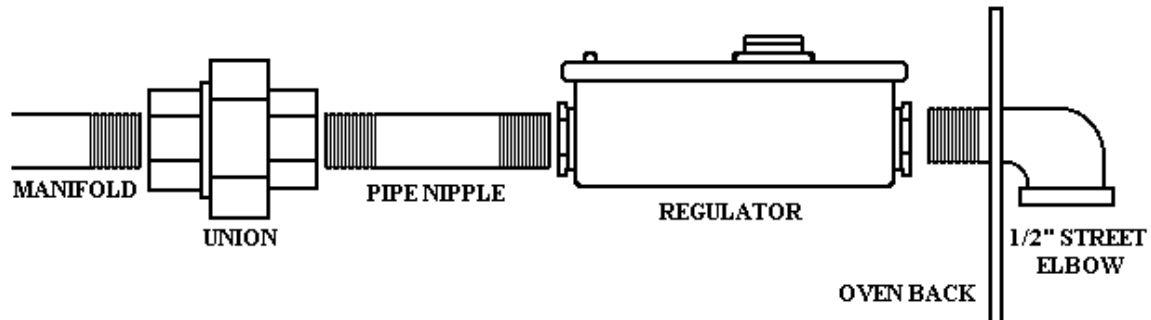

12. Illustrated below is the gas flow pattern from the manifold to the burner head. The necessary part numbers are listed for your convenience when ordering the flex tubing for the different lengths. The part numbers for the fixed orifices, Nat or LP, are also listed. Each burner is rated at 15,000 BTU's, NAT Gas and 13,500 BTU's on LP/Propane Gas.

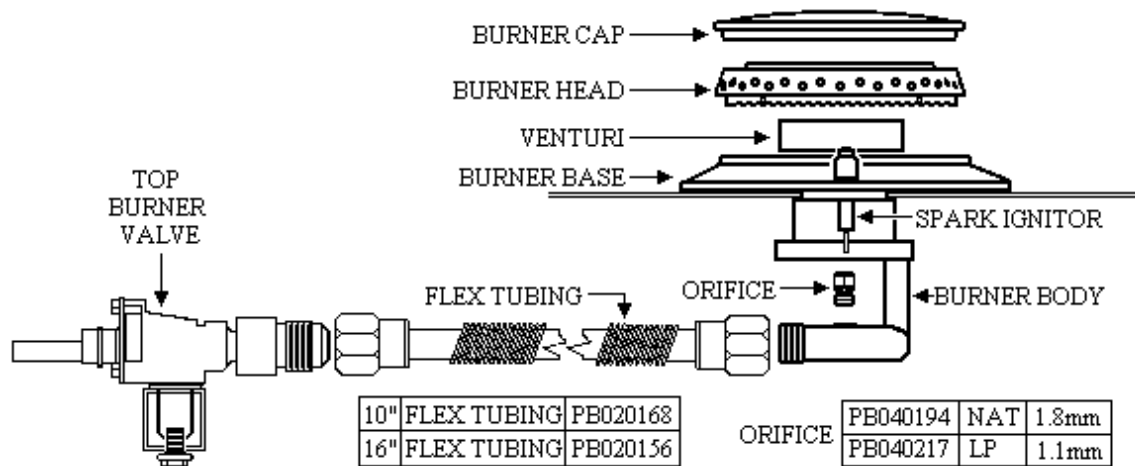

VDSC "LOCKED" DOOR

In the unlikely event the door lock motor should fail in the "locked" position you will need:

1. To fashion a hook on the end of a 12" long stiff wire.
2. Insert the hook between the door and the front frame assembly at the top, see "A" illustration at the right. The hook on the wire should be to the right of the latch hook.
3. Engage the door latch hook with the wire hook and pull the latch hook to the left until the door is released, see illustration below.

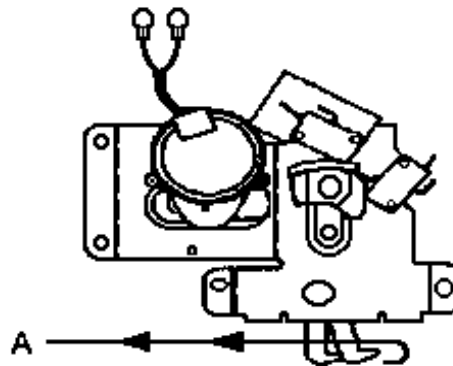
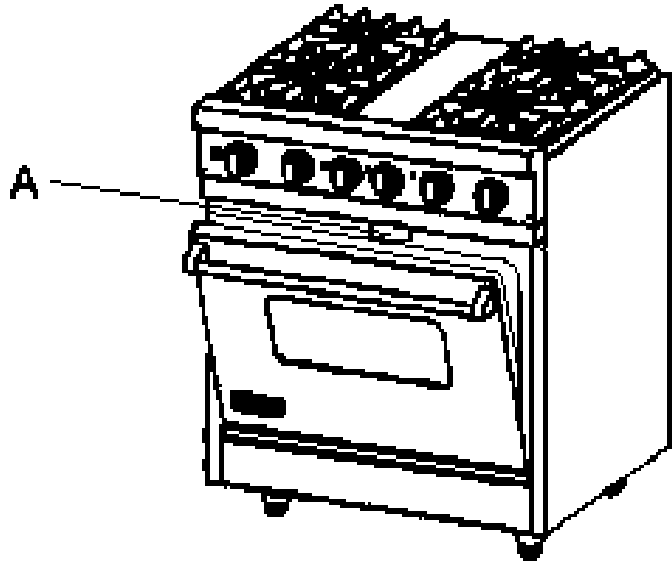

TROUBLESHOOTING GUIDE VDCSC (DUAL FUEL RANGES)

PROBLEM	PROBABLE CAUSE	CORRECTION
A. No Bake, No Broil No Cycle Light, No Power to Relay #1	A-1 House Breaker or Fuse open	A-1 Reset Breaker or replace Fuse
B. No Bake, No Broil, No Cycle Light, Power to Relay #1 (Red – Red/Blk terminals #1 & #3) No power to Relay #1 Heater	B-1 Timed Bake/Broil function switch set to Timed function. B-2 Power Relay #1 Heater circuit open . B-3 Open contacts Relay #2 (single/ upper oven) (wh/red wire to neutral pin #1 and #7) B-4 Open contacts Relay #3 (single/upper oven) (red/blu contact #3 to wh/vio contact #9) or open contact Relay #6 (lower oven) (Brown contact #3 to wh/vio contact #9) B-5 Open Thermostat Cycling contacts #1 and #2 B-6 Open High Limit Switch (contacts normally Closed)	B-1 Set Timed Bake/Broil function switch to manual. B-2 Replace Power Relay #1 (Power Relay #1 part # PM010026) B-3 Replace Relay #2 (single/ upper oven) or #5 (lower oven) (Relay #2 and #5 part # PM010029) B-4 Replace Relay #3 (upper oven) or Relay #9 (lower oven) (Relay part # PM010029) B-5 Replace Thermostat B-6 Replace High Limit Switch
C. No Bake Function Broil functions normal and the Cycle Light is on	C-1 Open Bake Element C-2 Open Selector Switch contacts 1 to L2 C-3 Burned Wiring or Terminal connections.	C-1 Replace Bake Element C-2 Replace Selector Switch C-3 Replace or Repair Burned Wiring and / or Terminal (spade) connector.
D. Poor Baking Results, Broil Functions normal Cycle Light is on	D-1 Low Voltage Supply (240VAC Required). D-2 Restricted Air Flow through the oven cavity. D-3 No Top Heat from Broil Element. Open selector Switch contacts 3 to E. D-4 Check Use and Care for suggested baking tips.	D-1 Inform Customer of requirements. D-2 Clear restriction from Oven Vent. D-3 Replace Selector Switch.
E. No Convection Bake, Bake and Broil functions normal, Cycle Light is on.	E-1 Open Selector Switch contact 6 to 1 E-2 Open Convection Motor winding E-3 Burned Wiring or terminal connections	E-1 Replace Selector Switch E-2 Replace Convection Motor Replace burned wiring or terminal connectors.
F. No Convection Cook, Bake and Broil functions normal. Cycle Light is on.	F-1 Open Convection Cook Element F-2 Open Selector Switch contacts 5 to L2	F-1 Replace Convection Cook Element. F-2 Replace Selector Switch

TROUBLESHOOTING GUIDE VDSC (DUAL FUEL RANGES)		
PROBLEM	PROBABLE CAUSE	CORRECTION
G. Convection Cook Heats, No Air Circulation	G-1 Open Winding in Convection Fan Motor G-2 Frozen Motor Shaft G-3 Open Selector Switch contacts 1 to 6	E-1 Replace Fan Motor E-2 Replace Fan Motor E-3 Replace Selector Switch
H. No Mini-Broil, Bake functions normal, Cycle Light is on.	H-1 Open Selector Switch contacts 3 to L2 H-2 Open Inside Broil Element	H-1 Replace Selector Switch H-2 Replace Inside Broil Element
I. No Maxi-Broil, Bake and Mini-Broil functions normal, Cycle Light is on.	I-1 Open Selector Switch contacts F to 4, 2 to L2 and / or 3 to L2 I-2 Open Outside Broil Element	I-1 Replace Outside Broil Element
J. No Maxi-Broil, No Top heat in Bake Mode, Cycle Light is on.	J-1 Open Selector Switch contacts F to 4, 2 to L2 J-2 Open Inside and Outside Broil Elements.	J-1 Replace Selector Switch J-2 Replace Open Broil Elements.
K. No Convection Broil Bake and Broil are Normal, Cycle Light Is on. No Mini-Broil	K-1 Open Convection Motor winding K-2 Open Selector Switch contacts 3 to L2 K-3 Open Inside Broil Element	K-1 Replace Convection Motor. K-2 Replace Selector Switch K-3 Replace Inside Broil Element
L. No Self-Clean, Bake and Broil functions normal ▪ Door won't lock. No Clean Light. No 120 VAC supply to Door Lock module / timer (PC board)	L-1 Open Selector Switch contacts J to 6 L-2 Open contacts Relay #2 (single/upper oven) or Relay #5 (lower oven). L-3 Open contacts Relay #3 (single/upper Oven) or Relay #6 (lower oven).	L-1 Replace Selector Switch L-2 Replace Relay #2 (single/upper oven) or #5 (lower oven). L-3 Replace Relay #3 (single/upper oven) or #6 (lower oven).
M. No Self-Clean Bake And Broil function Normal. ▪ Door won't Lock 120VAC to Door Lock module / timer (PC board) is present – No Motor movement – Clean Light is on.	M-1 Open Relay contacts LS1-1 and /or LS2-M1 on Door Lock Module / timer (PC board) M-2 Open contacts 1 to 2 on Auto Reset Thermostat. M-3 Open windings in Lock Motor	M-1 Replace Door Lock Module / Timer (PC board) M-2 Replace Auto Reset Thermostat M-3 Replace Lock Motor assembly

TROUBLESHOOTING GUIDE VDSC (DUAL FUEL RANGES)		
PROBLEM	PROBABLE CAUSE	CORRECTION
N. Door Lock Motor continues to run no signal to sensor #3 on PC board the closes T1-T2 and T3-T4. Clean Light is on.	N-1 No SW2 Switch (closed be motor Movement) on Door Lock Mechanism not closing.	N-1 Adjust SW2 Switch position or Replace faulty Switch.
O. Door Lock Motor Engaged. Signal To Sensor #3 on PC board . No Heat, Clean Light is on.	O-1 Door Lock Module / Timer Relay T1 –T2 and T3-T4 not closing.	O-1 Replace PC board.
P. Door Lock Motor Engaged. Cooling Fan Motor runs. (PC board T3 –T4 closing) No Heat.	P-1 Door Lock Module / Timer (PC board) Relay T1-T2 not closing. P-2 Door Lock Module / Timer (PC board) Relay T1-T2 closing. Check SW3 on Door Lock Assembly.	P-1 Replace PC board P-2 Replace SW3 switch on Door Lock Assembly .

Viking Range Corporation
111 Front Street, Greenwood, Mississippi (MS) 38930 USA (662) 455-1200

Viking products are marketed under the Ultraline brand name in Canada
F90192

Specifications subject to change without notice
(LP10/02)