

**SERVICE NOTEBOOK
REFRIGERATOR
VCBB360R / VCBB362R (Right) – VCBB360L / VCBB362L (Left)**



VIKING RANGE CORPORATION [®]

Table of Contents

Technical Information.....	3
Display Panel.....	4
Display Panel Operation.....	5
Electronic Functional Description.....	6
Power Disconnect Switch	
Showroom Switch	
Alarms	
Temperature Control Operation.....	7
Adaptive Defrost Operation.....	8
Program Mode.....	9
Electronic Testing.....	11
Electronic Function Description.....	12
Wiring Diagram.....	14
Wiring Schematic (Complete).....	15
Wiring Schematic (Freezer Compartment).....	16
Wiring Schematic (Refrigeration Compartment).....	17
Wiring Schematic (Refrigerator and Freezer Compartment).....	18
Wiring Schematic (Adaptive Defrost).....	19
Component Specification.....	20
Component Testing.....	23
Troubleshooting Charts.....	31
System Diagnosis.....	33
Service Procedures.....	34
Refrigerant Flow.....	40
Cabinet Airflow.....	41
Machine Compartment Air Flow.....	42
Typical External Sweat Pattern.....	43
Disassembly Procedures.....	44
Ice Maker.....	47
Ice Maker Troubleshooting Chart.....	52
Ice Maker Wiring Diagram and Part Layout.....	55

Technical Information – Refrigerator



To avoid electrical shock which can cause severe personal injury or death, disconnect power to refrigerator using power switch before servicing. Wires removed during disassembly must be replaced on proper terminals to insure correct earth ground and polarization. After servicing, reconnect power using power switch.

	Kw/24 hr ± 0.4	Percent Run Time ± 10%	Cycle/24 hr ± 25%	Refrigerator Center Compartment Food Average temperature ± 3°F	Freezer Compartment Food Average Temperature ± 3°F	
Ambient °F	65° 90° 110°	65° 90° 110°	65° 90° 110°	65° 90° 110°	65° 90° 110°	
	1.2 2.3 4.2	28 52 100	30 32 0	39 39 45	3 3 3	
Temperature Relationship Test Chart						
	T-1 Outlet ± 3°	F T-1 Inlet ± 3° F	T-3 Suction Line	Average Total Wattage ±10%	Suction Pressure ± 2 PSIG	Head Pressure ± 5 PSIG
			± 7°F			
Ambient °F	65° 110°	65° 110°	65° 110°	65° 110°	65° 110°	65° 110°
	-14 -14	-14 -14	25 103	157 168	0 0	110 157

Display Panel

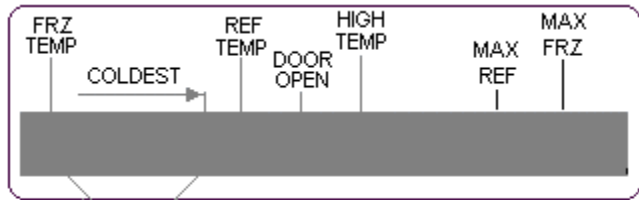

TEMPERATURE
DISPLAY LIGHTS

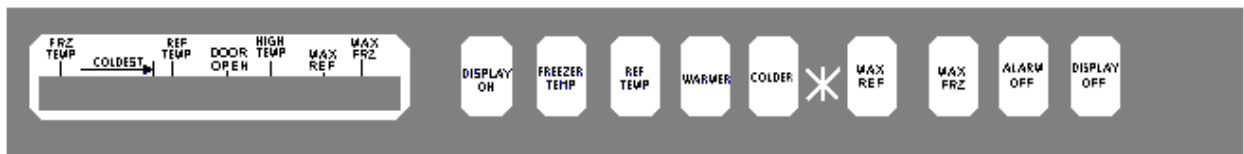
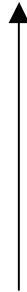

Display Panel Keyboard

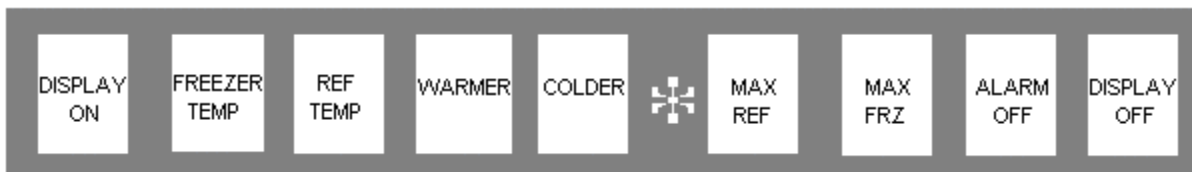

Display Panel Operation

Keyboard Tone

Entry Tone

Indicates a pad was pressed, command read and accepted, Turn off entry tone by pressing and holding *Display On* pad for 3 to 5 seconds.

Command Accepted Tone

Three short tones indicate command accepted.

Display On Pad

1. Activates control panel. Control panel remains active at least 10 minutes.
2. Turns off Power Up Alarm (flashing lights) after power is first plugged in or after power outage.

Note: All pads, except *Alarm Off*, are inactive until *display On* is pressed.

Freezer Temp Pad

Activates freezer temperature settings mode.

1. Freezer indicator light will glow. Freezer temperature setting will be displayed. Factory setting is 5.
2. Change freezer temperature setting by pressing *Warmer* or *Colder* pad.

Ref Temp Pad

Activates refrigerator temperature settings mode.

1. Refrigerator indicator light will glow. Refrigerator temperature setting will be displayed. Factory setting is 5.
2. Change refrigerator temperature setting by pressing *Warmer* or *Colder* pad.

Warmer Pad

Raises temperature settings one bar at a time. If entry tone is on, tone will sound at each bar level until top level is reached.

1. Turn on temperature setting function of control panel by pressing *Warmer* pad.
2. Press and hold *Warmer* pad to raise temperature setting at a faster rate.

Colder Pad

Lowers temperature setting one bar at a time. If entry tone is on, tone will sound at each bar level until bottom level is reached.

1. Turn on temperature setting function of control panel by pressing *Colder* pad.
2. Press and hold *Colder* pad to lower temperature setting at a faster rate.

Max Frz Pad

Activates Maximum freezer mode setting freezer temperature to coldest setting for 24 hours or until *Max Frz* pad is pressed again.

1. Freezer indicator light will glow.
2. To adjust maximum freezer mode time refer to Program Mode B functions.

Max Ref Pad

Activates Maximum refrigerator mode setting refrigerator to coldest setting for 24 hours or until *Max Ref* pad is pressed again.

1. Refrigerator indicator light will glow.
2. To adjust maximum refrigerator time refer to Program Mode B functions.

Alarm Off Pad

Turns off alarm signals. See Alarms section to interpret alarm signals.

1. Press and hold *Alarm Off* pad for 3 seconds to deactivate *Door Open* alarm. To reactivate *Door Open* alarm, press and hold *Alarm Off* pad for 3 seconds.
2. If *Alarm Off* pad is pressed and condition causing alarm is not corrected, alarm will reset.

**

Activates Program Mode. See Program Mode section for description of functions available.

1. Open refrigerator door.
2. Press *Display On* pad.
3. Press * pad.
4. Within 6 seconds press the following pads in this sequence; *Max Ref*, *Max Frz*, *Max Ref*, *Max Frz*.
5. Tone will sound 3 times and control will be in program mode A.

Display Off Pad

1. Deactivates control panel
2. Deactivates temperature indication area of control panel.

Electronic Functional Description

Power Disconnect Switch

Use power disconnect switch to disconnect power without unplugging refrigerator. Power disconnect switch is located behind air grille on top right side. Refrigerator is shipped with power disconnect switch in the on position.

Showroom Switch

Showroom switch allows electronic controls and interior lights to function independently of refrigeration system. Showroom switch is located behind air grille to right of control panel. Refrigerator is shipped with showroom switch in the unit run position.

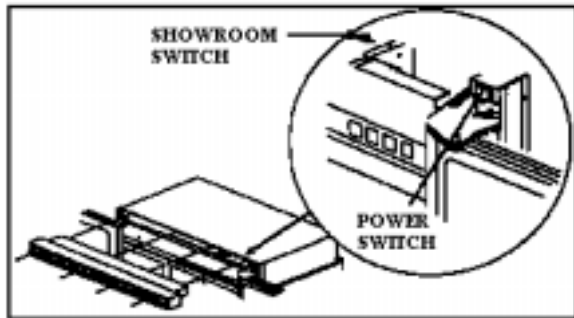

Alarms

Power Up Alarm

After power is initially plugged in, after a power loss, or if power switch is turned off, all temperature indicator lights will flash until *Alarm Off* or *Display On* is pressed.

Note: All settings return to default factory settings.

Door Open Alarm

Alarm tone sounds and indicator lights blink if either refrigerator or freezer door is open more than 3 minutes.

1. Turn off Door Open alarm by pressing *Alarm Off* pad or by closing door.
2. Deactivate door open alarm by pressing *Display On* pad and then press and hold *Alarm Off* pad for 3 seconds.
3. Door alarm delay can be adjusted in Program Mode B.

High Temperature Alarm

Alarm sounds and indicator light shows if freezer or refrigerator temperature has gone above critical level and remains warm for 2 hours. Alarm tone stops if temperature falls again.

1. Critical temperature for freezer is +15°F; for refrigerator critical temperature is +55°F.
2. Press *Alarm Off* to turn off alarm.

Thermistor Alarm

Alarm sounds and freezer or refrigerator indicator light shows and temperature indicators 4 through 7 will turn on in sequence if either thermistor circuit opens. Refer to Temperature Control Operation Section and Electronic Testing Section.

1. Press *Alarm Off* pad to turn off alarm.
2. Alarm will reset for normal operation. If condition has not been corrected, alarm will sound again.

Electronic Functional Description

Temperature Control Operation

For any temperature setting, outputs will be turned off/on based on cut-in, cut-out temperatures determined by resistance levels of freezer and refrigerator thermistors.

Refrigerator and Freezer Thermistor

Temp °F (+°C)	Resistance Ohms	Temp °F (+°C)	Resistance Ohms
-20 (-29)	495600	36 (2)	87510
-15 (-26)	418200	38 (3)	82740
-9 (-23)	354000	39 (4)	78300
-6 (-21)	300600	43 (6)	74100
-4 (-18)	256200	45 (7)	70170
5 (-15)	218850	46 (8)	66450
10 (-12)	187470	48 (9)	62970
16 (-9)	161040	50 (10)	59670
19 (-7)	138690	55 (13)	52290
25 (-4)	119760	61 (16)	45900
30 (-1)	103680	64 (18)	40410
32 (0)	97920	70 (21)	36540
34 (1)	92550	77 (25)	30000

As temperature decreases, resistance increases.

As temperature increases, resistance decreases.

Open thermistor or thermistor circuit will result in failure of refrigerator to cool.

Shorted thermistor will cause refrigerator to run 100 percent of time except for defrost cycle.

- Freezer temperature setting and thermistor value will determine if compressor/condenser fan and evaporator fan switches are open or closed. Compressor/condenser fan switch must be open for 6 minutes before switch can close again (compressor dwell time.)
- Refrigerator temperature setting and thermistor valve will determine if fresh food fan switch is open or closed.
- Cut-out and cut-in temperature values must be reached and maintained for 15 minutes before output state will change (digital delay).
- Refrigerator and freezer control calibration can be adjusted in Program Mode B.

Factory set freezer and refrigerator settings.

Electronic Functional Description

Adaptive Defrost Operation

Defrost occurs after predetermined length of compressor run hours. Compressor run time between defrost changes, or adapts, depending upon recent history of defrost lengths (time it takes for defrost terminator to open after defrost heater has been turned on).

- Defrost terminator opens at 55°F (-13°C) and closes at 20°F (-7°C).
- Compressor run time between defrost (CRDT) will be one of 3 values under normal operation CRDT 1 (8 hours) or CRDT 2 (12 hours) or CRDT 3 (15 hours).

If defrost length is low (DT-LO defined as 21 minutes) indication small frost load, CRDT for next defrost cycle is advanced to next level.

If defrost length is high (DI-HI defined as 24 minutes) indicating large frost load, CRDT for next defrost cycle is lowered to next level.

If defrost length is between 21 and 24 minutes, CRDT for next defrost cycle remains the same.

Initial value at power up CRDT is 4 hours.

- Vacation Mode CRDT equals 96 hours. Vacation Mode CRDT is interrupted with door openings. Defrost interval will revert back to interval before vacation mode. Three things must occur to reach Vacation Mode CRDT.
 - 1) Defrost interval must be CRDT 3 (16 hours).
 - 2) Both refrigerator and freezer doors must have remained closed since last defrost cycle.
 - 3) Defrost thermostat must have opened in less than 21 minutes during last defrost cycle.
- Six minutes dwell time occurs after defrost terminator opens before compressor and condenser fan motor will operate. Ten minutes dwell time occurs after defrost terminator opens before evaporator fan motor will operate. Dwell time can be bypassed by disconnecting power to the unit for 30 seconds.
- Conventional defrost can be selected in Program Mode B.

Program Mode

Accessing Program Mode

Two programming modes are available. Mode A allows reading refrigerator and freezer thermistor temperatures. Mode B is used for all other programmable functions.

1. Open refrigerator door.
2. Press *Display On* pad.
3. Press * pad.
4. Press the following sequence of pads within 6 seconds; Max Ref, Max Frz, Max Ref, Max Frz.
5. When access is granted, tone will sound three times and control will be in Program Mode A. Unmarked indicator light will illuminate.
6. Toggle to Program Mode B by pressing *Display On* pad. Unmarked indicator light is off.

EEPROM Update in Control Memory

EEPROM is permanent programmable memory of the control panel.

- Entry tone, door audio alarm and status are stored in EEPROM after control is deactivated.
- Information stored in EEPROM memory is not affected by power loss.

Mode A Function

Reading Temperature Display

Temperature display will show thermistor temperature in binary coded decimal format (BCD).

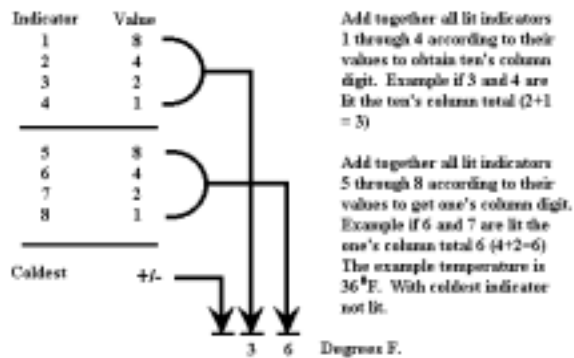

Indicator lights 1 through 4 represent the ten's digit with 1 being the most significant bit. Indicator lights 5 through 8 represent one's digit with 5 being the most significant bit. Positive and negative are shown by indicator light 9. Light glows to show negative value.

Freezer Thermistor Temperature

1. Choose freezer thermistor temperature display by pressing *Freezer Temp* pad.
2. Freezer thermistor temperature displays.

Refrigerator Thermistor Temperature

1. Choose refrigerator thermistor temperature display by pressing *Ref Temp* pad.
2. Refrigerator thermistor temperature displays.

Mode B Functions

Automatic Keyboard Functions

Activate and deactivate keyboard by toggling *Display Off* pad. If high temperature indicator glows, keyboard will disable after 10 minutes. If high temperature indicator is off, keyboard is always enabled. **DO NOT LEAVE KEYBOARD IN ENABLE MODE AFTER PROGRAMMING IS COMPLETE.**

Door Alarm Delay

1. Press *Alarm Off* pad. Door open indicator will glow. One temperature indicator should glow indicating present delay setting in minutes (indicator 1 means 1 minute, 2 means 2 minutes, etc.). Default delay is 3 minutes.
2. Press *Warmer* pad to decrease delay by 1 minute.
3. Press *Colder* pad to increase delay by 1 minute.

Max Ref Run Time Duration

1. Press *Max Ref* pad. Max Ref light will glow. One temperature indicator should glow indicating present Max Ref run time duration in 2 hour increments (indicator 1 means 2 hours, 2 means 4 hours, etc.). Default delay is 10 hours.
2. Press *Warmer* pad to decrease Max Ref duration by 2 hours.
3. Press *Colder* pad to increase Max Ref duration by 2 hours.

Program Mode

Max Frz Run Time Duration

1. Press *Max Frz* pad. Max Frz light will glow. One temperature indicator should glow indicating present Max Frz run time duration in 4 hour increments (indicator 1 means 4 hours, 2 means 8 hours, etc.) Default delay is 24 hours.
2. Press *Warmer* pad to decrease Max Frz duration by 4 hours.
3. Press *Colder* pad to increase Max Frz duration by 4 hours.

Temperature Offset Calibration

Offset amount adjusts temperatures for refrigerator cut-ins and cut-outs by the amount of offset. The chart below shows the indicator and the amount of offset from the factory default setting.

INDICATOR	OFFSET
1	+8
2	+6
3	+4
4	+2
5	+0
6	-2
7	-4
8	-6
Coldest	-8

- Setting refrigerator Temperature Offset. Press *Ref Temp* pad. Refrigerator indicator and one indicator will glow. Press *Warmer* pad to move offset to the next warmer setting. Press *Colder* pad to move to the next colder setting. Factory default refrigerator offset is +2.

- Setting Freezer Temperature Offset. Press *Freezer* pad. Freezer temperature indicator and one indicator will glow. Press *Warmer* pad to move offset to the next warmer setting. Press *Colder* pad to move offset to the next colder setting. Factory default freezer offset is 0.

Defrost Mode Selection

Toggle (*) pad to select adaptive or conventional defrost mode. Vacation indicator glows when adaptive defrost has been selected. If vacation indicator is off, conventional defrost is selected. Conventional defrost uses 8 hour CRDT value.

Forced Defrost

Defrost can be forced to start by pressing and holding the *Alarm Off* pad for 3 seconds. Program changes will be saved permanently in EEPROM and program mode will exit to Run Mode.

Forced Pull down (Compressor Start)

Compressor start can be forced by pressing and holding Max Frz for 3 seconds. Program changes will be saved permanently in EEPROM. Compressor, evaporator fan, damper heater, and condenser fan will come on.

Exiting Program Mode

Press *Display On* pad for 3 seconds to exit Program Mode. Tone will sound three times. Changes made in Program Mode will be permanently saved in EEPROM.

Note: If no pad is pressed for 10 minutes, Program Mode will be automatically exited. However, no changes will be saved if Program exits automatically.

Electronic Testing

Electronic Testing Mode

Forced Defrost Start

1. Press *Display On* pad to activate control panel.
2. Simultaneously press and hold Max Ref and *Display Off* pads for 3 seconds.

Forced Compressor Start

1. Press *Display On* pad to activate control panel.
2. Simultaneously press and hold Max Frz and *Display Off* pad for 3 seconds.

Open Thermistor Detect

Alarm sounds and freezer or refrigerator indicator light shows and temperature indicators 4 through 7 will turn on in sequence if either thermistor circuit opens. Refer to Temperature Control Operation Section and Electronic Testing Section.

1. Press Alarm Off pad to turn off alarm.
2. Alarm will retest for normal operation. If condition has not been corrected, alarm will sound again.

Evaporator Fan Suppression

The evaporator fan will turn off every time either refrigerator or freezer door is open.

To test if this function is operating:

1. Perform forced pull down procedure as noted above--evaporator fan should be on.
2. Open the refrigerator or freezer door--the fan should turn off.
3. Push the light switch off--the evaporator fan should start.

If fan does not toggle off and on when refrigerator light switch is turned off and on it has been determined evaporator fan motor operational, perform following tests to determine failure:



1. Check for line voltage on terminal E7 on high voltage board. With refrigerator door open (refrigerator light ON) reading should be 120-VAC. With door closed (refrigerator light OFF) reading should be approximately 0 VAC. If voltage does not change with light switch and light is turning light off and on red/white wire is broken between switch and high voltage board.
2. Check for voltage on terminal E7 on high voltage board. Output voltage should toggle with toggling of light switch. If it does not toggle, high voltage board needs replacing.
3. If terminal 7 on high voltage board changes with opening and closing of door, orange wire in low voltage harness is broken (check for continuity between pin 7 on high voltage board and pin 10 on low voltage board) or low voltage board needs replacing.



1. Check for line voltage on terminal E8 on high voltage board. With freezer door open, reading should be 120VAC. With door closed, reading should be approximately 0 VAC. If voltage does not change with light switch and light switch is turning light off and on, violet/white wire is broken between switch and high voltage board.
2. Check for voltage on pin 7 on pin connector of high voltage board. Output voltage should toggle with toggling of light switch. If it does not toggle, high voltage board needs replacing.
3. If voltage on pin 7 on pin connector on high voltage board changes with opening and closing of door, orange wire in low voltage harness is broken (check for continuity between pin 7 on high voltage pin connector and pin 10 on low voltage board) or low voltage board needs replacing.

Electronic Function Description

WARNING: To avoid electrical shock which can cause severe personal injury or death, disconnect power to refrigerator using power switch before servicing. Wires removed during disassembly must be replaced on proper terminals to insure earth ground and polarization. After servicing, reconnect power using power switch.

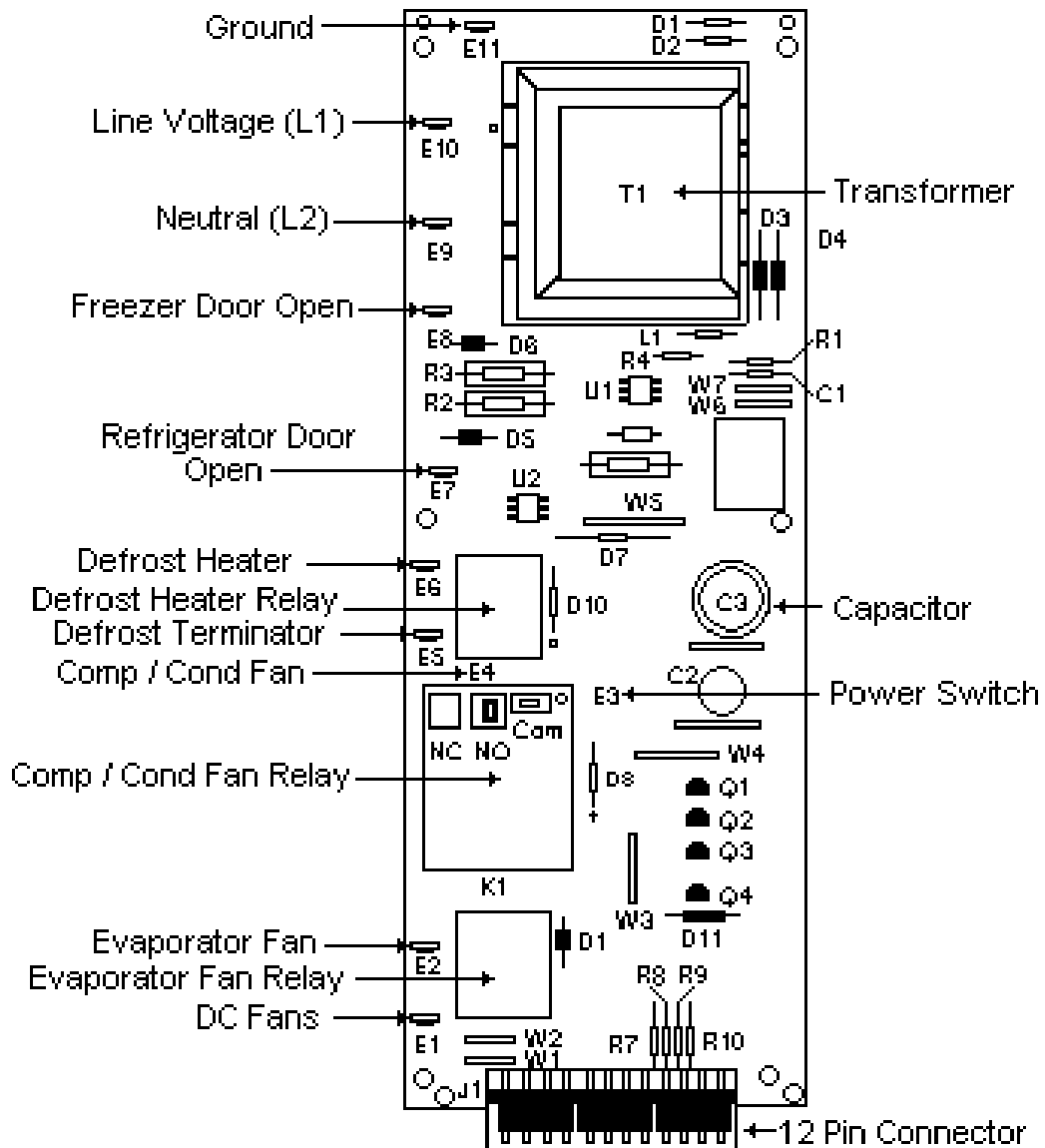

Electronic Function Description



WARNING

To avoid electrical shock which can cause severe personal injury or death, disconnect power to refrigerator using power switch before servicing. Wires removed during disassembly must be replaced on proper terminals to insure correct earth ground and polarization. After servicing, reconnect power using power switch

Refrigeration and Defrost Component Checks Made at High Voltage Board

Low voltage board input	W1 to D11 E10 to E9 (Neutral) or ground	approximately -25VDC approximately 120VDC
Compressor/condenser fan motor	“ON” = E4 to E9 (Neutral) or ground “OFF” = E4 to E9 (Neutral) or ground	approximately 120VDC
Compressor/condenser fan motor relay	“CLOSED” = R7 to ground “OPEN” = R7 to ground	approximately -11VDC approximately -25VDC
Evaporator fan motor relay	“CLOSED” = R8 to ground “OPEN” = R8 to ground	approximately -11VDC approximately -25VDC
Evaporator fan motor	“ON” =E2 (Neutral) or ground “OFF” = E2 (Neutral) or ground	approximately 120VDC 0VDC
Defrost heater	“ON” = E6 to E9 (Neutral) or ground “OFF” = E6 to E9 (Neutral) or ground	approximately 120VDC 0VDC
Defrost heater relay	“CLOSED” = R9 to ground “ OPEN” = R9 to ground	approximately -11VDC approximately -25VDC
Defrost terminator	“CLOSED” =E5 to E9 (Neutral) ground “OPEN” = E5 to E9 (Neutral) or ground	approximately 120VDC 0VDC
DC fan output voltage from high voltage board to fresh food fan or condensate evaporator fan	“ON” = E1 to ground “OFF” = E1 to ground	approximately -25VDC 0VDC
DC fan input voltage signal to high voltage board from low voltage board for fresh food fan and for condensate evaporator	“ON” =R10 to ground “OFF” = R10 to ground	approximately -11VDC approximately -25VDC

Filament voltage at pin 11 and 12 = less than 5VDC

Wiring Diagram



WARNING To avoid electrical shock which can cause severe personal injury or death, disconnect power to refrigerator using power switch before servicing. Wires removed during disassembly must be replaced on proper terminals to insure correct earth ground and polarization. After servicing, reconnect power using power switch.

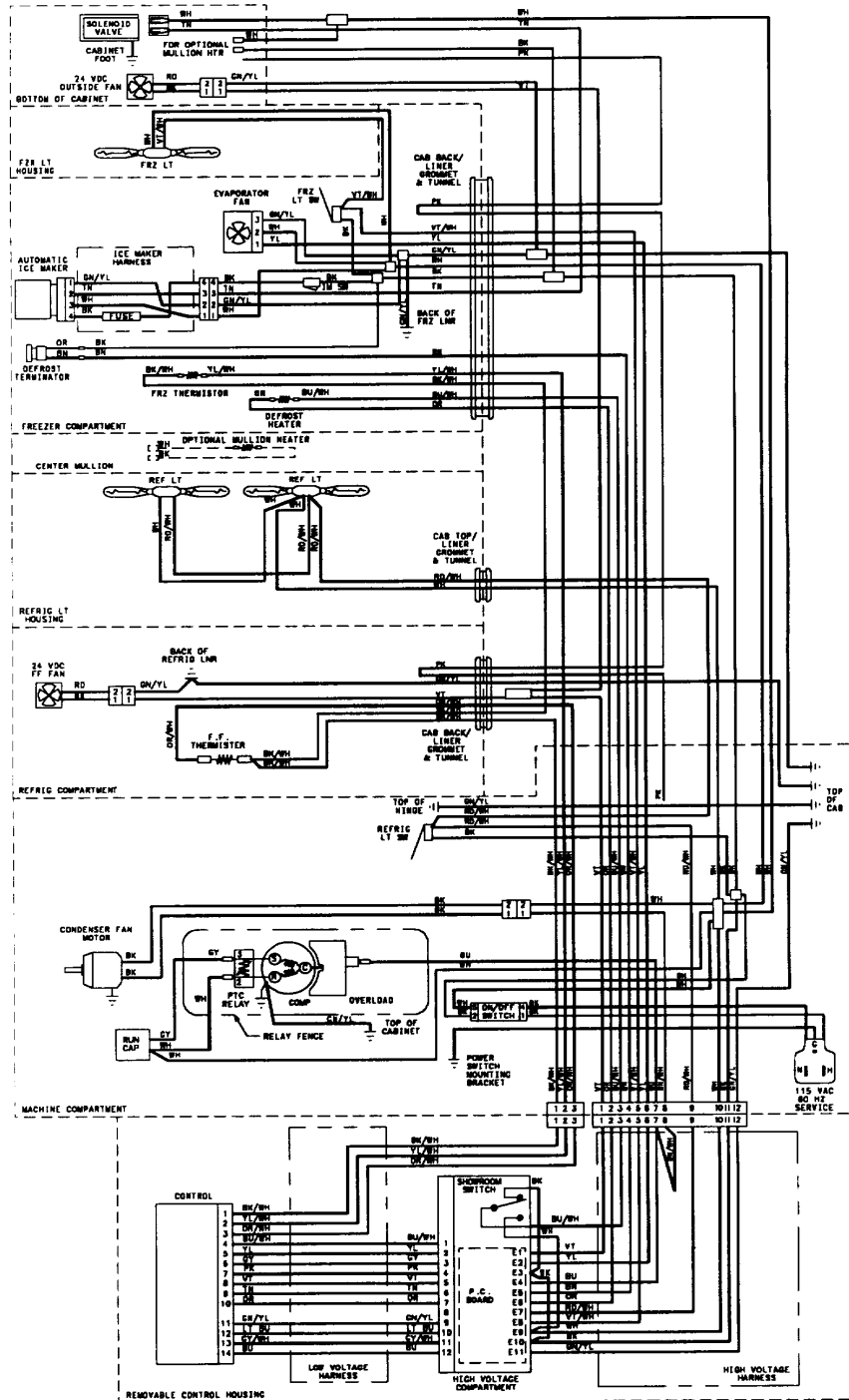

Wiring Schematic



To avoid electrical shock which can cause severe personal injury or death, disconnect power to refrigerator using power switch before servicing. Wires removed during disassembly must be replaced on proper terminals to insure correct earth ground and polarization. After servicing, reconnect power using power switch

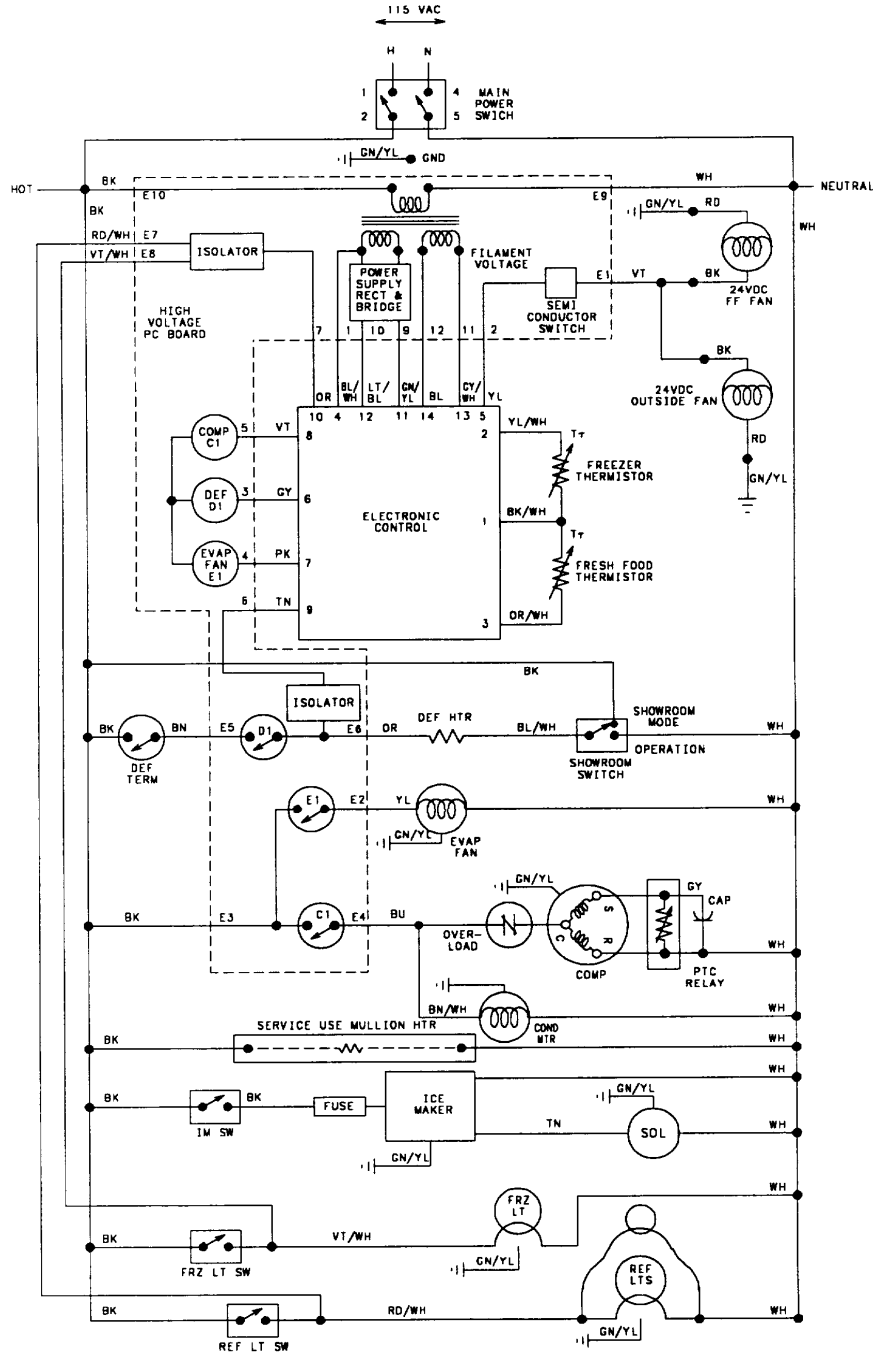

Electronic Function Description



WARNING: To avoid electrical shock which can cause severe personal injury or death, disconnect power to refrigerator using power switch before servicing. Wires removed during disassembly must be replaced on proper terminals to insure correct grounding and polarization. After servicing, reconnect power using power switch.

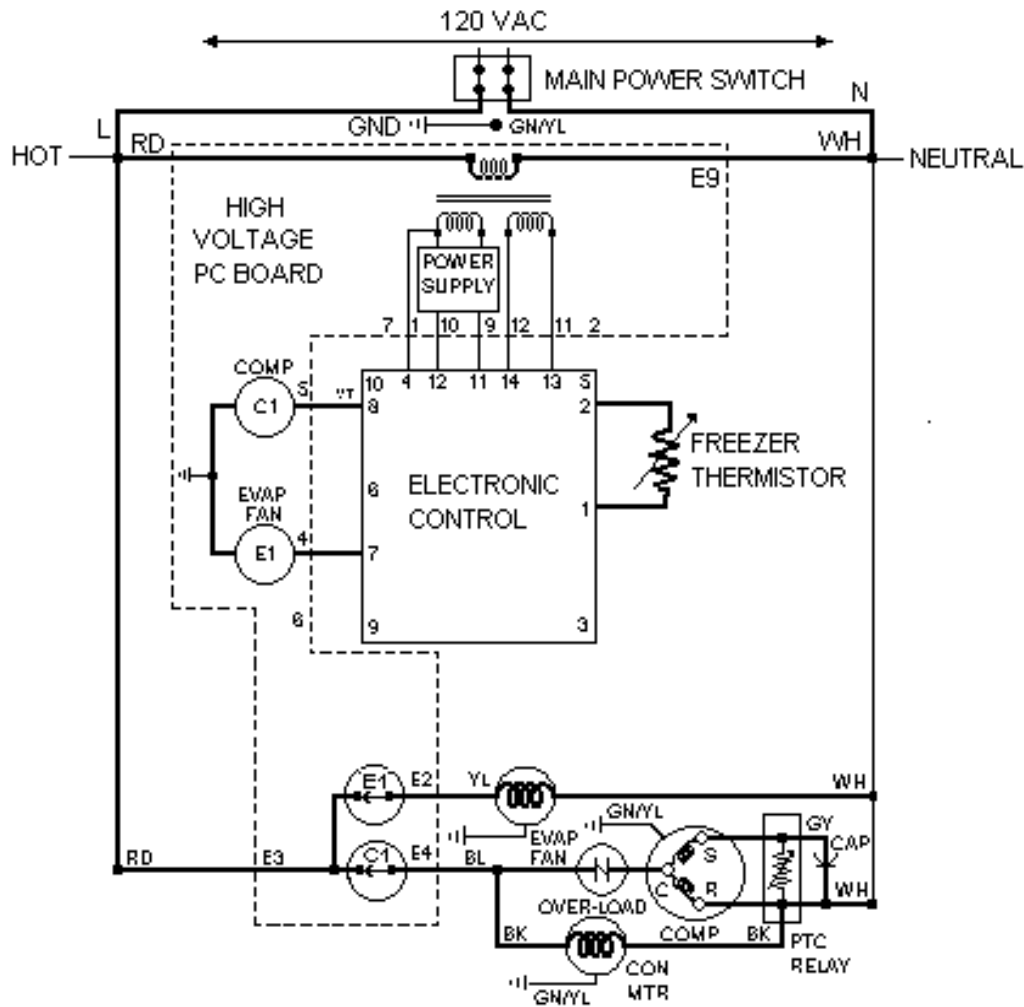

Freezer Compartment Theory of Operation

As a freezer thermistor warms, the resistance decreases allowing low voltage signal to be sent to electronic control. Electronic control sends two low voltage signals, one to the compressor relay coil (C1) and one to the evaporator relay coil (E1).

When both relay coils are energized and both relay contacts are closed, high voltage circuits to evaporator fan motor and compressor / condenser fan motor are complete.

As thermistor cools during refrigeration cycle, resistance through thermistor increases blocking low voltage signal to electronic control interrupting circuit.

Electronic Function Description



WARNING: To avoid electrical shock which can cause severe personal injury or death, disconnect power to refrigerator using power switch before servicing. Wires removed during disassembly must be replaced on proper terminals to insure correct grounding and polarization. After servicing, reconnect power using power switch.

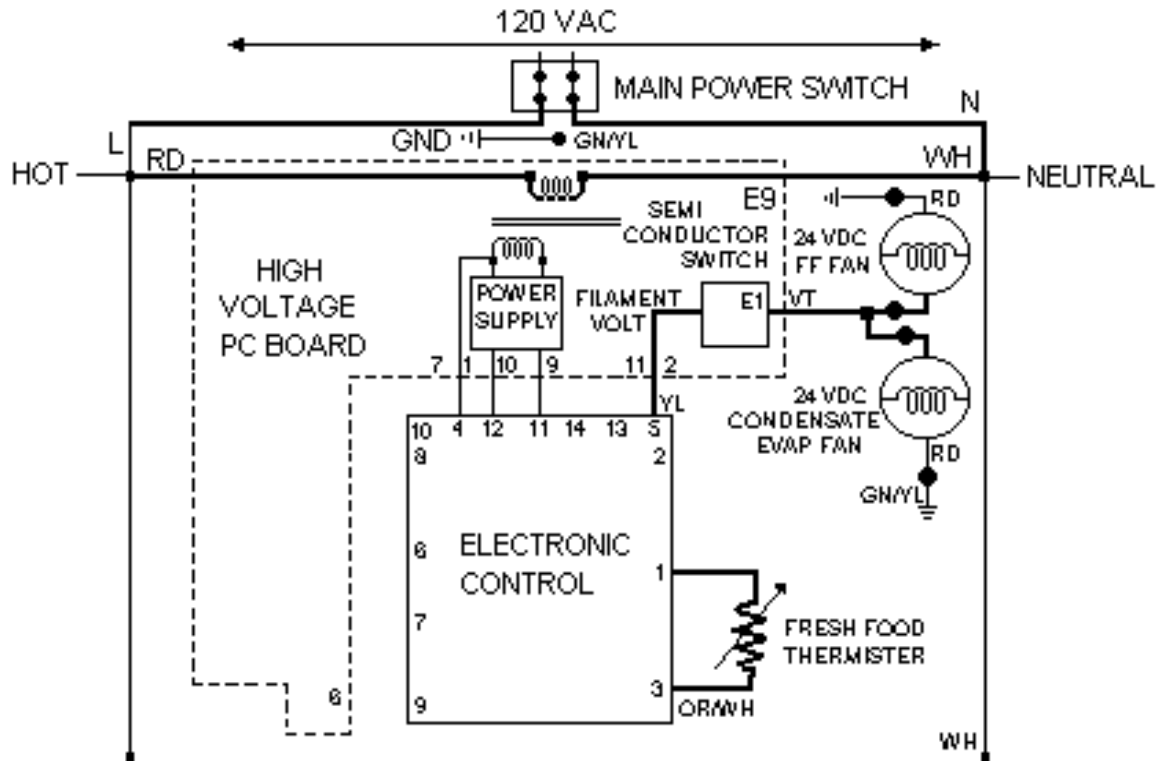

Refrigeration Compartment Theory of Operation

As fresh food thermistor warms, resistance decreases allowing low voltage signal to be sent to the electronic control. Electronic control sends a low voltage signal, to semiconductor switch for DC fresh food fan and DC condensate evaporator fan.

Both fans begin operating. Fresh food fan circulates freezer air into fresh food compartment. Condensate evaporator fan circulates air over condensate drain pan aiding in evaporation.

As fresh food thermistor cools, resistance increases blocking low voltage signal to electronic control interrupting circuit to DC fresh food fan and DC condensate evaporation fan.

Electronic Function Description



WARNING: To avoid electrical shock which can cause severe personal injury or death, disconnect power to refrigerator using power switch before servicing. Wires removed during disassembly must be replaced on proper terminals to insure correct grounding and polarization. After servicing, reconnect power using power switch.

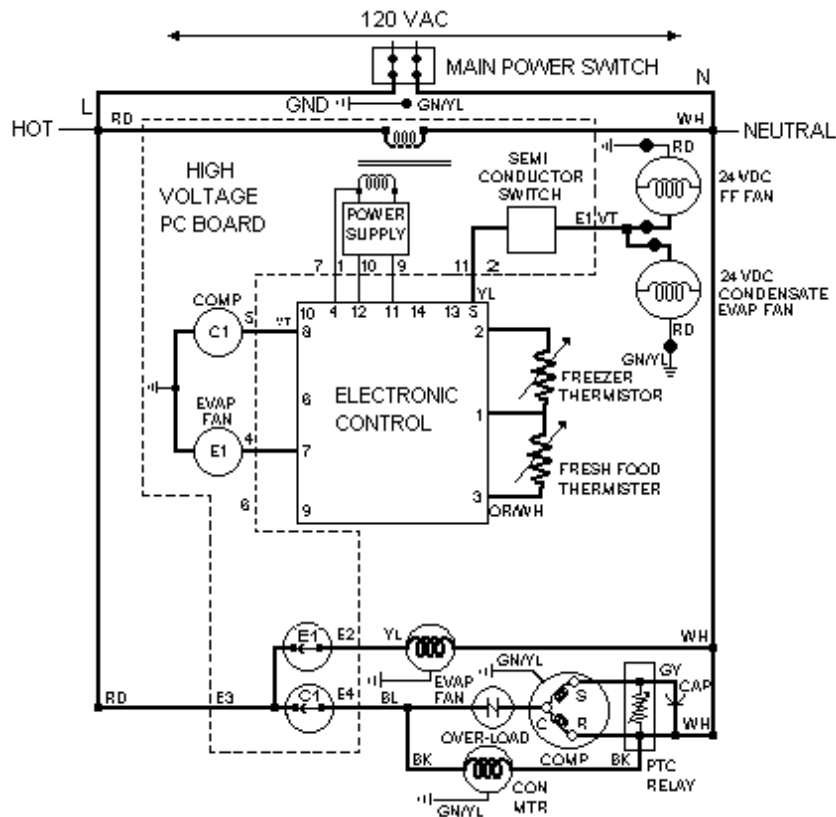

Refrigerator and Freezer Compartment Theory of Operation

If both freezer and fresh food thermistors are warm, their resistance drops (see table Refrigerator and Freezer Thermistor in Temperature Control Section) and the electronic signals for compressor / condenser fan motor operation and for operation of fresh food and condensate evaporator fans.

After freezer thermistor cools sufficiently to raise resistance and block the signal to the electronic control, compressor / condenser fan motor will shut off.

However, fresh food and condensate evaporator fans will continue to run until fresh food thermistor cools and signal is blocked to electronic control.

If fresh food thermistor cools before freezer thermistor, electronic control will interrupt circuit to fresh food and condensate evaporator fans while evaporator fan motor will continue to operate under control of freezer thermistor.

Electronic Function Description



WARNING: To avoid electrical shock which can cause severe personal injury or death, disconnect power to refrigerator using power switch before servicing. Wires removed during disassembly must be replaced on proper terminals to insure correct grounding and polarization. After servicing, reconnect power using power switch.

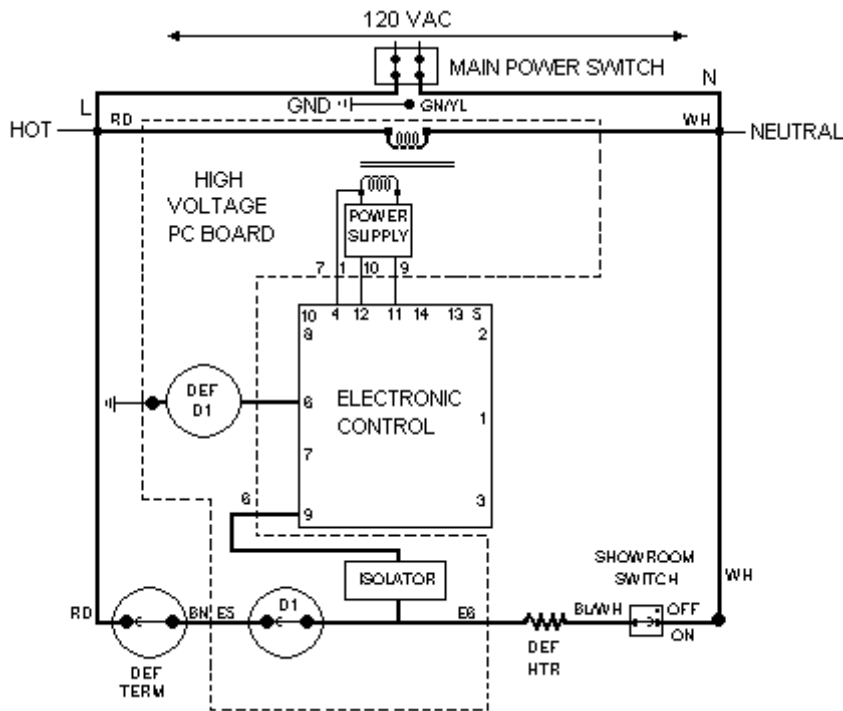

IMPORTANT: When the showroom switch is OFF, the isolator sees line voltage which keeps the electronic controller from signaling the evaporator fan motor or compressor relay coils and also keeps the fresh food and condensate evaporation fans off.

Adaptive Defrost Theory of Operation

After designated compressor run time, refrigeration cycle is interrupted and electronic control sends a low voltage signal to defrost relay coil (def D1).

Powering the relay coil closes contact (D1) completing high voltage circuit to defrost heater through closed defrost terminator (closes at 15 F).



Isolator, which is part of high voltage PC board, recognizes presence of line voltage to defrost heater and sends low voltage signal to electronic control.

Electronic control keeps count of number of minutes, defrost terminator remains closed (opens at 48 F).

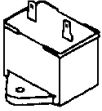
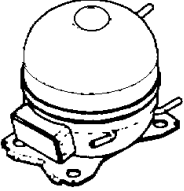

Length of time defrost terminator is closed determines if the next defrost cycle advances by 4 hours of compressor run, stays at the same interval, or delays by 4 hours of compressor run.

If defrost terminator does not open before 29 minutes, defrost cycle is automatically terminated by electronic control and refrigeration cycles will resume after 6 minutes dwell time.



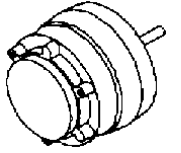
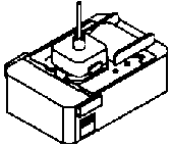
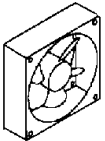
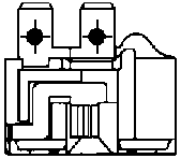
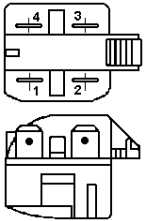
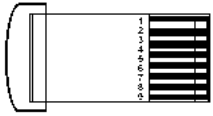
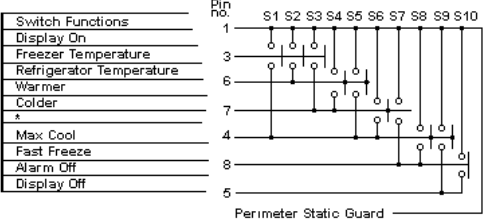

Component Specifications

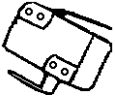
Component	Description	Test Procedures
	Bulb	Volts 120VAC Watts 40 watts
	Capacitor, compressor run	Volts 220VAC Capacitance 15 µfc + 10% - 5%
	Compressor Type	Fan cooled, R134a refrigerant BTUH 970 BTUH Volts 120VAC 60Hz Watt 176 watts Current: Lock rotor 21.3 A Full load 1.6 A Resistance: Run windings 2.60Ω Start windings 4.35Ω
	Drier	Drier must be changed every time the system is opened for testing or compressor replacement. Desiccant (20) 8x12.4AXH – 7 M. S.-Grams
	Heater, evaporator	Volt 120VAC Wattage 450 ±5% W Resistance 30 ± 5% Ω
	Heater, Mullion For service use only, foamed in place. Not powered from the factory.	Volt 120VAC Wattage 20Watts Resistance 661 ± 7.5Ω <div style="border: 1px solid black; padding: 5px;"> WARNING</div> <p>To avoid risk of electrical shock which can cause death or severe injury, disconnect electrical power to unit before servicing.</p> <p>To connect mullion heater to power:</p> <ol style="list-style-type: none">1. Disconnect power to unit using power switch.2. Remove toe grille. Locate water valve wiring harness.3. Carefully, slit wiring harness vinyl sleeve to expose one black and one white lead bent with bullet terminators.4. Locate mullion heater leads at the left side of cabinet and connect to black and white leads.5. Wrap vinyl sleeve with electrical tape to close slit.
	High voltage circuit board P.C.	See “Electronic Functional Description”.
	Low voltage circuit board	See “Electronic Functional Testing”.

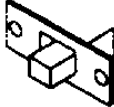

Component Specifications

	<p>Motor, condenser PSC</p>	<p>Volt Rotation (facing end opposite shaft) RPM Watt Current Resistance</p>	<p>120 VAC Clockwise 1300 RPM 6.4 Watts 0.05 Amp 480 Ω</p>																						
	<p>Motor, ECM evaporator fan.</p>	<p>Volt Rotation (facing shaft) RPM Watt</p>	<p>120VAC Counterclockwise 2150 RPM 1.4 Watts</p>																						
	<p>Motor and blade, Refrigerator, condenser, evaporator fan.</p>	<p>Volt Rotation (facing shaft) RPM Watt</p>	<p>120VAC Counterclockwise 3300 RPM 1.4 Watts</p>																						
	<p>Overload</p>	<p>Volt Ult. Trip amps @158°F (70°C) Close temperature Open temperature Short time trip (seconds) Short time trip (amps @ 77°F (925°C)</p>	<p>120VAC 3.51 Amps 142°F (61°C) ± 9° 257°F (125°C) ± 5° 10 seconds 14 amps.</p>																						
	<p>Relay</p>	<p>Resistance with power off check across terminals 2 & 3. Shorted Open</p>	<p>3 – 12 Ω 0 Ω very high or infinite ohms.</p>																						
<div style="display: flex; align-items: center;"> <div style="flex: 1;"> <p>Switch Keyboard</p>  </div> <div style="flex: 2;"> <table border="1"> <thead> <tr> <th>Switch Functions</th> <th>Pin no.</th> </tr> </thead> <tbody> <tr><td>Display On</td><td>1</td></tr> <tr><td>Freezer Temperature</td><td>2</td></tr> <tr><td>Refrigerator Temperature</td><td>3</td></tr> <tr><td>Warmer</td><td>4</td></tr> <tr><td>Colder</td><td>5</td></tr> <tr><td>Max Cool</td><td>6</td></tr> <tr><td>Fast Freeze</td><td>7</td></tr> <tr><td>Alarm Off</td><td>8</td></tr> <tr><td>Display Off</td><td>9</td></tr> <tr><td>Perimeter Static Guard</td><td>10</td></tr> </tbody> </table> </div> <div style="flex: 1;">  </div> </div>				Switch Functions	Pin no.	Display On	1	Freezer Temperature	2	Refrigerator Temperature	3	Warmer	4	Colder	5	Max Cool	6	Fast Freeze	7	Alarm Off	8	Display Off	9	Perimeter Static Guard	10
Switch Functions	Pin no.																								
Display On	1																								
Freezer Temperature	2																								
Refrigerator Temperature	3																								
Warmer	4																								
Colder	5																								
Max Cool	6																								
Fast Freeze	7																								
Alarm Off	8																								
Display Off	9																								
Perimeter Static Guard	10																								
	<p>Switch, auger</p>	<p>Type Volts Current</p>	<p>DPST, NO 250 / 125 VAC 10 / 5 Amp.</p>																						
	<p>Switch, refrigerator light (left opening door hinge)</p>	<p>Type Volt Current</p>	<p>SPST, NC 125 / 25 VAC 3 Amps.</p>																						

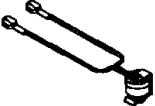
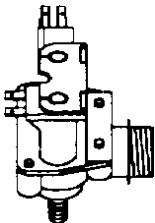
Component Specifications

	Switch, refrigerator light (Right opening door hinge)	Type Volt Current	SPST, NC 125 / 250 VAC 3 Amps
	Switch, power	Type Volt Current	DPST 125 / 250 VAC 15 Amps
	Switch, freezer light, sealed	Type Volt Current	SPST, NC 125 / 250 VAC 5.0 Amps.
	Switch, showroom	Type Volt Current	SPDT 125VAC 6 Amps
	Thermister	Check resistance across Terminals. Bell curve Resistance (see page 13) @77°F @45°F	30,000 ohms ± 1% ohms 68,000 ohms ± 2% ohms
	Thermostat	Volt Watt Current Resistance across terminals Above 55°F ± 6°F Below 20°F ± 8°F Between 55°F ± 6°F And 20°F ± 8°F	120VAC 1000 Watts 10 Amps Open Closed Will stay in current state (either Open or closed) until either 55°F ± 6°F and 20°F ± 8°F is reached.
	Valve, water	Volt Watt Water pressure (inlet) Max Min Fill rate	120VAC, 60Hz. 20 Watts 120psi 20psi 140 ± 10 CC's at 7.5 seconds.

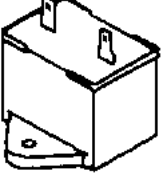
Component Testing

Component	Description	Testing
<p>Capacitor</p> 	<p>Run capacitor connects to relay terminals 3 and L2 side of line.</p>	<div style="border: 1px solid black; padding: 5px; margin-bottom: 10px;">  <p>WARNING</p> <p>To avoid electrical shock which can cause severe personal injury or death, discharge capacitor through a resistor before handling</p> </div> <ol style="list-style-type: none"> 1. Disconnect power to refrigerator 2. Remove captor cover and disconnect capacitor wires. 3. Discharge capacitor be shorting across terminals with a resistor for 1 minute. 4. Check resistance across capacitor terminals with ohmmeter set on “Rx1K “scale. <ul style="list-style-type: none"> • Good—needle swings to 0 ohms and slowly moves back to infinity. • Open—needle does not move. Replace capacitor • Shorted—needle moves to zero and stays. replace capacitor. • High resistance leak—needle jumps toward 0 and then moves back to constant high resistance (not infinity)
<p>Capillary tube</p>	<p>Capillary is sized in diameter, and length to feed proper amount refrigerant to evaporator.</p> <p>Capillary is soldered to suction line to transfer heat from capillary and add additional superheat to gas refrigerant in compressor suction line.</p>	<p>Restricted or clogged capillary tube must be replaced with tube of same inner diameter and length.</p>

Component Testing

Component	Description	Test Procedures
Compressor	<p>When compressor electrical circuit is energized, the start winding current causes relay to heat. After an amount of starting time, start winding circuit turns off. Relay will switch off start winding circuit even though compressor has not started (for example, when attempting to restart after momentary power interruption).</p> <p>With “open” relay, compressor will not start because there is little or no current to start windings. Overload protection will open due to high locked rotor run winding current.</p> <p>With “shorted” relay or capacitor, compressor will start and overload Protector will quickly open due to high current of combined run and start windings.</p> <p>With open or weak capacitor, compressor will start and run as normal but will consume more energy.</p>	<p>Resistance test</p> <ol style="list-style-type: none"> 1. Disconnect power to unit. 2. Discharge capacitor by shorting across terminals with a resistor for 1 minute. 3. Remove leads from compressor terminals. 4. Set ohmmeter to lowest scale. 5. Check for resistance between Terminals “S” and “C” Terminals “R” and “C” <p>If either compressor winding reads open (infinite or very high resistance) or dead short (0 ohms), replace compressor.</p> <p>Ground Test</p> <ol style="list-style-type: none"> 1. Disconnect power to refrigerator. 2. Discharge capacitor by shorting terminals through a resistor for 1 minute. 3. Remove compressor leads and use an ohmmeter set on highest scale. 4. Touch one lead to compressor body (clean point of contact and the other probe to each compressor terminal. If a reading is obtained, compressor is grounded and must be <p>Operation Test</p> <p>If voltage, capacitor, overload, and motor winding test good, perform the following test.</p> <ol style="list-style-type: none"> 1. Disconnect power to refrigerator using power switch. 2. Discharge capacitor by shorting capacitor terminals through a resistor for 1 minute. 3. Remove leads from compressor terminals. 4. Wire a test cord to power switch. 5. Place time delayed fuse with UL rating equal to amp rating of motor in test cord socket. 6. Remove overload and relay. 7. Connect start, common and run leads of test cord on appropriate terminals of compressor. 8. Attach capacitor leads of test cord together. If capacitor is used, attach capacitor to a known good capacitor of

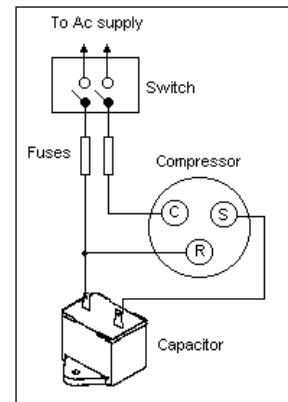

Component Testing

Compressor	Description	Test Procedure
		<p>9. Plug test cord into volt-watt meter to determine start and run wattage as well as check for low voltage which can also be a Source of trouble.</p> <p>10. With power to voltmeter, press start cord switch and release.</p> <ul style="list-style-type: none"> • If compressor motor start and draws normal wattage, compressor is okay and trouble is in capacitor, relay / overload, freezer temperature control , or elsewhere in system. • If compressor does not start when direct wired, recover system at high side. After system is recovered, repeat compressor direct wire test. If compressor runs after recovery, a restriction is indicated. • If compressor does not run when wired direct after recovery <u>replace faulty compressor.</u>
Condenser	<p>Condenser is of tube and wire Construction located in Compressor compartment</p> <p>Condenser is on high pressure discharge side of compressor transfer heat absorbed by refrigerant to ambient.</p> <p>Higher pressure gas is routed to condenser where, as gas temperature is reduced, gas condenses into a high pressure liquid state. Heat transfer takes place because discharge gas is at a higher temperature than air that is passing over condenser. It is very important that adequate air flow over condenser is maintained.</p> <p>Condenser is air cooled by Condenser fan motor. If efficiency of heat transfer from condenser to surrounding air is impaired, condensing temperature becomes higher. High liquid temperature means the liquid will not remove as much heat during boiling in evaporator as under normal head pressure, long run time, and high wattage.</p> <p>From compressor refrigerant Flows into serpentine under Condensate pan to help evaporate condensate, and then into pre-condenser loop which helps control exterior condensation on flange, center mullion, and around freezer door.</p>	<p>Leaks in condenser can usually be determined by using an electronic or soap solution. Look for signs of compressor oil when checking for leaks. A certain amount of compressor oil is circulated with refrigerant.</p> <p>Leaks in post condenser loop are rare because loop is a one-piece copper tube except for brazed joint visible in machine.</p> <p>For Minute Leaks:</p> <ol style="list-style-type: none"> 1. Separate condenser from rest of refrigeration system and pressurize condenser up to a maximum of 9.65 bars (140psi) with a refrigerant and dry nitrogen combination. 2. Recheck for leaks. <div style="text-align: center; margin: 10px 0;">  WARNING </div> <p>To avoid severe personal injury or death from sudden eruption of high pressure gases, observe the following:</p> <ul style="list-style-type: none"> • Protect against a sudden eruption if high pressure are required for leak checking. • Do not use high pressure compressed gases in refrigeration systems without a reliable pressure regulator and pressure relief valve in the lines.

Component Testing

Compressor	Description	Test Procedure
	<p>From condenser refrigerant flows into capillary and then to evaporator before returning to compressor through suction line.</p>	
<p>Drier</p> 	<p>Drier is placed at post condenser loop outlet and passes liquefied refrigerant to capillary. Desiccant (20) 8x12 4AXH-7 M.S. Grams.</p>	<p>Drier must be changed every time the system is opened for testing or compressor replacement. NOTE: Drier used in R12 sealed system is not interchangeable with drier used in R134a sealed system.</p> <p>Before opening refrigeration system, recover HFC 134a refrigerant for safe disposal.</p> <ol style="list-style-type: none"> Score capillary tube close to drier and break. Reform inlet tube to drier allowing enough space for large tube cutter. <p style="text-align: center;">CAUTION</p> <p>To avoid death or severe personal injury, cut drier at correct location. Cutting drier at incorrect location will allow desiccant beads to scatter. If spilled, completely clean area of beads</p> <ol style="list-style-type: none"> Cut circumference of drier 1/4" below condenser inlet tube joint to drier. Remove drier. Apply heat trap paste on post condenser tubes to protect grommets from high heat. Unbrazed remaining part of drier. Remove drier from system. Discard drier in safe place. Do not leave drier with customer. If refrigerator is under warranty, old drier must accompany warranty claim.
<p>Evaporator</p>	<p>Inner volume of evaporator allows liquefied refrigerant discharged from capillary to expand into refrigerant gas.</p> <p>Expansion cools evaporate tube and fin temperature to approximately -20°F transferring heat from freezer section to refrigerator.</p> <p>Passing through suction line to compressor, the refrigerant picks up superheat (a relationship between pressure and temperature that assures complete vaporization of liquid refrigerant) as result of capillary in suction line.</p>	<p>Test for leaks in evaporator with electronic leak detector or with soap solution. Compressor oil is circulated with refrigerant, check for oil when checking for leaks. NOTE: Follow all procedures for recovering R134a Refrigerant for safe disposal when opening system.</p> <p>For Minute Leaks.</p> <p style="text-align: center;">WARNING</p> <p>To avoid severe personal injury or death from eruption of high pressure gasses, observe the following:</p> <ol style="list-style-type: none"> Protect against a sudden eruption if high pressures are required for leak checking. Do not use high pressure compressed gasses in refrigeration systems without a reliable pressure regulator and pressure relief valve in the line.



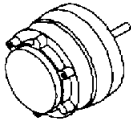
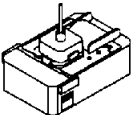

Component Testing

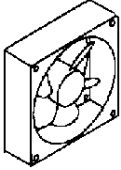
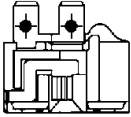
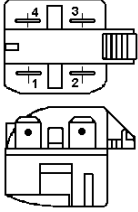
Compressor	Description	Test Procedure
	Refrigerant gas is pulled through suction line by compressor to complete the refrigerant cycle.	<ol style="list-style-type: none"> 1. Separate evaporate from rest of refrigeration system and pressurize evaporator up to a maximum of 235 PSI with a refrigerant and dry nitrogen combination. 2. Recheck for leaks.
Heater, cavity	Applied to back of ice and water cavity to help prevent condensation from forming on face of cavity. Wire in series with hot side of line through auger motor interlock switch.	<p>Check resistance across heater.</p> <p>If heater is faulty, use spare heater foamed in place at factory.</p>
Heater, evaporator (defrost)	See "Electronic Function Description, Adaptive Defrost Circuitry.	<p>Check resistance across heater.</p> <p>To check defrost system:</p> <ol style="list-style-type: none"> 1. Thermocouple defrost thermostat and plug refrigerator into wattmeter. 2. Force into defrost mode (see section on electronic testing) Wattmeter should read specified watts (according to Technical Data Sheet) ± 5 F; thermostat should interrupt power to heater
Heater mullion	<p>For service use only to reduce condensation on center mullion.</p> <p>Heater formed in place. Not powered from the factory.</p>	<p>⚠ WARNING To avoid risk of electrical shock, personal injury, or death, disconnect power to unit before servicing.</p> <p>To connect mullion heater to power:</p> <ol style="list-style-type: none"> 1. Disconnect power to unit using power switch. 2. Remove ice grille. 3. Remove bracket holding condenser evaporation fan and water valve. 4. Locate water valve wiring harness. 5. Carefully slit wiring harness vinyl sleeve to expose one black and one white lead with bullet terminals inside harness sleeve. 6. Connect to heater leads at left side of cabinet. 7. Wrap vinyl sleeve with electrical tape to close slit.
Icemaker	See "icemaker" section for service information.	
Motor Condenser 	Condenser fan moves cooling air across condenser coil and compressor body.	Check resistance across motor windings
Motor Evaporator 	Evaporator motor moves air across evaporator coil.	<ol style="list-style-type: none"> 1. Disconnect power to unit. 2. Disconnect fan motor leads. 3. Check resistance from ground connection solder. Trace to motor frame must not exceed .05 ohms. 4. Check for voltage at connection to motor.

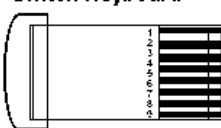
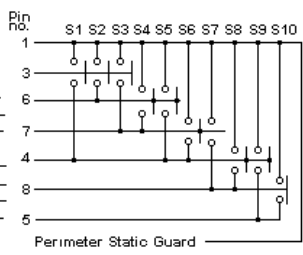

Component Testing

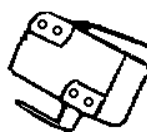
Compressor	Description	Test Procedure
<p>Motor, DC</p> 	<p>Refrigerator fan circulates cold air into refrigerator</p> <p>Condensate evaporation fan and out through toe grille to assure complete condensate evaporation.</p> <p>DC fan motors are connected in series with semiconductor switch.</p>	<p>See Refrigeration and Defrost Component Checks Made at High Voltage Board. For DC fan voltage check procedures at High Voltage Board.</p> <p>Check for voltage across terminals.</p>
<p>Overload / Relay</p> 	<p>Overload is a temperature and current sensing device.</p> <p>Overload opened when high current or high compressor temperature is sensed.</p> <p>After overload opens, reset can require up to two hours depending on ambient temperature and residual heat load in compressor.</p>	<ol style="list-style-type: none"> 1. Disconnect power to the refrigerator. 2. Remove relay cover and pull relay off compressor. Pull overload protector off compressor common terminal. 3. With ohmmeter, check the resistance between male terminal and female pin receptacle terminal which pushes onto Compressor common terminal. At ambient room temperature Overload protector should have less than 1 ohm resistance. An open overload protector will have infinite resistance. <p>Relay (See PTC Relay).</p>
<p>Relay, PTC</p> 	<p>When voltage is connected and relay is cool, current passed through relay to start winding. After a short time, current heats the resistor in relay and resistance will rise blocking current flow through relay. start winding remains in the circuit through run capacitor.</p> <p>Solid state relay plugs directly on compressor start and run terminals. Relay terminals 2 and 3 are connected within relay. Run capacitor is connected to relay terminals 3. L2 side of the 120 VAC power is connected to relay terminal 2.</p>	<p>With power off check resistance across terminals 2 and 3. Refer to Technical Data Sheet for values for model being serviced.</p>

Component Testing

Compressor	Description	Test Procedure											
Switch, keyboard	<p>Semiconductor Switch for control panel keyboard Electronic control is not repairable. If any component is faulty, entire control must be replaced.</p> <p>NOTE: Repair or replaced line voltage components before testing or replacing electronic control. Do not assume problems are caused by electronic control system. Opened, shorted, grounded or otherwise faulty line voltage components (including power cord and wiring) can create problems that appear to be caused by electronic control.</p>	<div style="display: flex; align-items: flex-start;"> <div style="margin-right: 20px;">  <p>Switch Keyboard</p> </div> <div style="margin-right: 20px;"> <table border="1" style="font-size: small;"> <tr><th>Switch Functions</th></tr> <tr><td>Display On</td></tr> <tr><td>Freezer Temperature</td></tr> <tr><td>Refrigerator Temperature</td></tr> <tr><td>Warmer</td></tr> <tr><td>Colder</td></tr> <tr><td>*</td></tr> <tr><td>Max Cool</td></tr> <tr><td>Fast Freeze</td></tr> <tr><td>Alarm Off</td></tr> <tr><td>Display Off</td></tr> </table> </div> <div>  </div> </div>	Switch Functions	Display On	Freezer Temperature	Refrigerator Temperature	Warmer	Colder	*	Max Cool	Fast Freeze	Alarm Off	Display Off
Switch Functions													
Display On													
Freezer Temperature													
Refrigerator Temperature													
Warmer													
Colder													
*													
Max Cool													
Fast Freeze													
Alarm Off													
Display Off													
Switch, NO 	Interrupts connection to ice maker when freezer door is open .	Check resistance across terminals. Switch arm depressed closed Switch arm not depressed open											
Switch, NC 	Completes circuit to allow indicated function. See tech sheet and wiring diagram for individual switch.	Check resistance across terminals. Switch arm down "NC" terminals closed "NO" terminals open Switch arm up "NC" terminals open "NO" terminals closed											
Switch, power DPST 	Disconnect all power to unit when switch is OFF (open) Unit shipped with switch ON.	Check resistance across terminals Switch OFF (open) No continuity between 1&2, 4&5 Switch ON (closed) continuity between 1&2, 4&5											

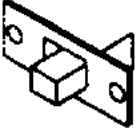
Component Testing

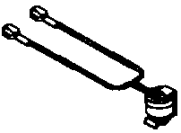
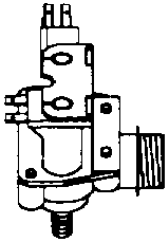
Compressor	Description	Test Procedure
<p>Switch, showroom SPDT</p> 	<p>ON position completes circuit to lights and display only</p> <p>OFF position completes circuit for normal operation.</p> <p>Unit shipped with switch in OFF position.</p>	<p>Check resistance at test points.</p> <p>Showroom operation –E3 at high voltage board to pin 3 (blue/white wire) at high voltage wire harness.</p> <p>Unit run—E9 at high voltage board to pin 3 (blue/white wire) at high voltage wire harness.</p>
<p>Thermistor</p> 	<p>Senses temperature within Refrigerator and freezer.</p>	<p>Check resistance across terminals. See Technical Date Sheet for bell curve resistance chart at given temperature.</p>
<p>Thermostat</p> 	<p>Thermostat is in a series circuit with high voltage board and defrost heater.</p> <p>Controls the circuit through defrost terminator to defrost heater. Opens and breaks circuit when thermostat senses present high voltage.</p> <p>After defrost thermostat opens thermostat remains open until end of defrost cycle and refrigerator starts cooling again. When defrost thermostat senses a preset low temperature and closes.</p>	<p>With power off and evaporator coil below freezing thermostat should check continuous when checked with ohmmeter. See “Heater, evaporator (defrost)” section for additional tests.</p>
<p>Valve, water</p> 	<p>controls water flow to the ice Maker.</p>	<p>Check resistance across coil windings. See Technical Data Sheet for valves for model being serviced.</p>

Troubleshooting Guide

Symptom	Possible Causes	Corrective Action
Unit does not run	No power to unit	Check for power at outlet. Check fuse box / circuit breaker for blown fuse or tripped breaker. Replace or reset.
	Faulty service cord	Check with test light at unit, if no circuit and current is indicated at outlet, replace or repair.
	Low voltage	Check input voltage for proper voltage. Take appropriate action to correct voltage supply problem.
	Freezer temperature set too warm	Adjust freezer temperature.
	Faulty timer	Check with test light. Replace if necessary.
	Faulty relay	Check relay. Replace if necessary.
	Faulty compressor	Check compressor motor windings for opens / shorts. Perform compressor direct wiring test. Replace if necessary.
	Faulty overload	Check overload for continuity. NOTE: Ensure compressor / overload are below trip temperature before testing. Replace if necessary.
Refrigerator section too warm	Excessive door opening	Consumer education.
	Overloading of shelves	Consumer education.
	Warm or hot foods placed in cabinet	Consumer education.
	Refrigerator temperature set too warm.	Adjust refrigerator temperature.
	Poor door seal	Level cabinet. Adjust hinges. Replace gasket.
	Dirty condenser	Clean condenser.
	Refrigerator airflow	Check airflow grille for obstructions. Adjust as necessary. Check airflow fan. Replace if faulty.
	Interior light remains on	Check switch. Replace if necessary.
	Faulty condenser fan or evaporator fan	Check fan switch, fan, and wiring. Replace if necessary.
Faulty compressor	Check intake valve. Replace compressor.	
Refrigerator section too cold	Refrigerator temperature set too cold.	Adjust refrigerator temperature.
	Refrigerator airflow not properly adjusted	Adjust airflow grille to freezer. Adjust Chef's pantry temperature control.
Refrigerator section too cold	Refrigerator temperature set too cold	Adjust refrigerator temperature.
	Refrigerator airflow not properly adjusted.	Adjust airflow grille to freezer. Adjust Chef's pantry temperature control.
Freezer section too cold	Freezer temperature set too cold	Adjust freezer temperature.
Unit runs continuously	Temperature set too cold	Adjust temperature.
	Dirty condenser or obstructed grille	Check condenser and grille. Clean.
	Poor door seal	Level cabinet. Adjust hinges. Replace gasket.
	Interior light remains on	Check switch. Replace if necessary.
	Faulty condenser fan or evaporator fan	Check fan switch, fan, and wiring. Replace if necessary.
	Refrigerant shortage or restriction	Check for leak or restriction. Repair, evacuate and recharge system.

Symptom	Possible Causes	Corrective Action
	Air in system	Check for low side leak. Repair, evacuate and recharge system.
Unit runs continuously. Temperature normal	Ice on evaporator	See "Ice on evaporator."
Noisy operation	Loose flooring or floor not firm	Repair floor or brace floor.
	Cabinet not level	Level cabinet.
	Tubing in contact with cabinet, other tubing or other metal	Adjust tubing.
	Drip tray vibrating	Adjust drain pan.
	Fan hitting another part	Ensure fan properly aligned and all attaching hardware and brackets are tight and not worn. Tighten or replace.
	Worn fan motor bearings	Check motor for loss of lubricant or worn bearings. Replace if necessary.
	Compressor mounting grommets worn or missing; mounting hardware loose or missing.	Tighten hardware. Replace grommets if necessary.
	Free or loose parts causing or allowing noise during operation	Inspect unit for parts that may have worked free or loose or missing screws. Repair as required.
Frost or ice on evaporator	Evaporator fan faulty	Check fan motor. Replace if defective.
	Defrost heater remains open	Check defrost heater continuity. Replace if faulty.
	Defrost thermostat faulty	Check defrost thermostat and replace if faulty.
	Open wire to connector	Check wiring and connections. Repair as necessary.
	Refrigerant shortage or restriction	Check for leak or restriction. Repair, evacuate and recharge system.
Unit starts and stops frequently (cycles on & off)	Loose wire or thermostat connections	Check wiring and connections. Repair as necessary.
	High ambient temperature	Consumer education.
	Supply voltage out of specifications.	Check input voltage. Correct and supply problems.
	Overload protector open	Check overload protector for continuity. If open, replace overload. NOTE: Ensure overload / compressor are below trip temperature before testing.
	Faulty compressor motor capacitor	Check capacitor for open / short. Replace if necessary. NOTE: Discharge capacitor before testing.
	Faulty compressor	Test and replace compressor if faulty.
	Faulty fan motor	Check fan motor. Replace if necessary.
	Restricted air flow	Check condenser and grille for dirt. Clean.
	Refrigerant shortage or restriction	Check for leak or restriction. Repair, evacuate and recharge system.

System Diagnosis

Pressure and Temperature Relationship Chart

(See Service Procedures for additional information about items in this chart.)

Condition	Suction Pressure Variation from Normal	Head Pressure Variation from Normal	T1 Inlet Temperature Variation from Normal	T2 Outlet Temperature Variation from Normal	T3 Suction Temperature Variation from Normal	Wattage Variation from Normal
Refrigerant Overcharge	Increase	Increase	Warmer	Warmer	Colder	Increase
Refrigerant Shortage	Decrease	Decrease or Increase (Restriction Symptoms)	Colder	Warmer	Warmer	Decrease
Partial Restriction	Decrease	Decrease or Increase (Restriction Symptoms)	Colder	Warmer	Warmer	Decrease
Air in System	Near Normal	Increase	Warmer	Warmer	Warmer	Increase
Low Ambient Installation (Reverse from High Ambient Installation)	Decrease	Decrease	Colder	Warmer	Warmer	Decrease
Additional Heat Load	Increase	Increase	Warmer	Warmer	Warmer	Increase
Inefficient Compressor	Increase	Normal or Decrease	Warmer or Colder	Warmer	Warmer	Decrease

Service Procedures



To avoid risk of electrical shock, personal injury, or death, disconnect electrical power source to unit and discharge capacitor through resistor before attempting to service, unless test procedures require power to be connected. Ensure all ground wires are connected before certifying unit as repaired and / or operational

Service Equipment

Listed below is equipment needed for proper servicing of HFC134a systems. Verify equipment is confirmed by manufacturer as being compatible with HFC134a and ester oil system.

Equipment must be exclusively used for HFC134a. Exclusive use of equipment only applies to italic items.

- **Evacuation Pump**
Check with vacuum pump supplier to verify equipment is compatible for HFC134a. Robinair, Modes 15600, 2 stage, 6 cubic feet per minute pump is recommended.
- **Four-way manifold gauge set, with low loss hoses .**
- **Leak detector**
- **Charging cylinder**
- **Line piercing saddle valve**
(Schroeder valves). Seals must be HFC134a and ester oil compatible. Line piercing valves may be used for diagnosis but are not suitable for evacuation or charging, due to minute holes pierced in tubing. Do not leave mechanical access valves on system. Valves eventually will leak. Molecules of HFC134a are smaller than other refrigerants and will leak where other refrigerants would not.
- **Swagging tools**
- **Flaring tools**
- **Flux**
- **Sil-flos**
- **Silver solder**
- **Oil for swagging and flaring**
- **Copper tubing**
- **Dry nitrogen**
99.5% minimum purity, with -40°F or lower dew point.
- **Crimp tools**
- **Tube bender**
- **Micron vacuum gauge**
- **Process tube adaptor**
- **Heat trap paste**
- **ICI appliance grade HFC134a**

Refrigerant Precautions



To avoid personal injury, do not allow refrigerant to contact eyes or skin.



To avoid risk of property damage, do not use refrigerant other than that shown on unit serial number identification plate.

NOTE; All precautionary measures recommended by refrigerant manufacturers and suppliers apply and should be observed.

Line Piercing Valves

Line piercing valves can be used for diagnosis, but are not suitable for evacuating or charging due to holes pierced in tubing by valves.

NOTE; Do not leave line piercing valves on system. Connection between valve and tubing is not hermetically sealed. Leaks will occur.

Open Lines

During any processing of refrigeration system, never leave lines open to atmosphere. Open lines allow water vapor to enter system, making proper evacuation more difficult.

Service Procedures



To avoid risk of electrical shock, personal injury, or death, disconnect electrical power source to unit and discharge capacitor through resistor before attempting to service, unless test procedures require power to be connected. Ensure all ground wires are connected before certifying unit as repaired and / or operational

Dehydrating Sealed Refrigeration System

Moisture in a refrigerator sealed system exposed to heat generated by the compressor and motor reacts chemically with refrigerant and oil in the system and forms corrosive hydrochloric and hydrofluoric acids. These acids contribute to the breakdown of motor winding insulation and corrosion of compressor working parts, causing compressor failure.

In addition, sludge, a residue of the chemical reaction, coats all surfaces of sealed system, and will eventually restrict refrigerant flow through capillary tube.

To dehydrate sealed system. Evacuate system (see paragraph **Evacuation**).

Leak Testing



To prevent serious injury or death from violent explosions, NEVER use oxygen or acetylene for pressure testing or clean out of refrigeration systems. Free oxygen will explode on contact with oil. Acetylene will explode spontaneously when put under pressure.

It is important to check sealed system for refrigerant leaks. Undetected leaks can lead to repeated service calls and eventually result in system contamination, restrictions, and premature compressor failure.

Refrigerant leaks are best detected with halide or electronic leak detectors.

Testing Systems Containing a Refrigerant Charge

1. Stop the operation (turn refrigerator off.)
2. Holding leak detector exploring tube as close to system tubing as possible, check all piping, joints, and fittings.

NOTE: Use soap suds on areas leak detector cannot reach or reliable test.

Testing Systems Containing No Refrigerant Charge

1. Connect cylinder of nitrogen, through gauge manifold, to process tube of compressor and liquid line strainer.
2. Open valves on nitrogen cylinder and gauge manifold. Allow pressure to build within sealed system.
3. Check for leaks using soap suds.

If leak is detected in tubing, replace tubing. If leak is detected in either coil, replace faulty coil.

Restrictions (Symptoms)

Restrictions in sealed system most often occur at capillary tube or filter drier, but can exist anywhere on liquid side of system.

Restrictions reduce refrigerant flow rate and heat removal rate. Wattage drops because compressor is not circulating normal amount of refrigeration.

Common causes of total restrictions are moisture, poorly soldered joints, or solid contaminants. Moisture freezes at evaporator inlet end of capillary tube. Solid contaminants collect in filter drier.

If restriction is on low side, suction pressure will be in a vacuum and head pressure will be near normal.

If restriction is on high side, suction pressure will be in a vacuum and head pressure will be higher than normal during pump out cycle.

Refrigeration occurs on low pressure side of partial restriction. There will be a temperature difference at the point of restriction. Frost and /or condensation will be present in most cases at the point of restriction. Also system requires longer to equalize.

Slight or partial restriction can give the same symptoms as refrigerant shortage including lower than normal back pressure, head pressure, wattage, and warmer temperatures.

Total restriction on the discharge side of compressor when restriction is between compressor and first half of condenser results in higher than normal head pressure and wattage while low side is being pumped out.

Testing for Restrictions

To determine if a restriction exists:

1. Attach gauge and manifold between suction and discharge sides of sealed system.
2. Turn unit on and allow pressure on each side to stabilize. Inspect condenser side of system. Tubing on condenser should be warm and temperature should be equal throughout (no sudden drops at any point along tubing.)

Service Procedures

Testing for Restrictions (continued)

- If temperature of condenser tubing is consistent throughout, go to step 4.
 - If temperature of condenser tubing drops suddenly at any point, tubing is restricted at point of temperature drop (if restriction is severe, frost may form at point of restriction and extend down in direction of refrigerant flow in system). Go to step 5.
3. Visually check system for kinks in refrigeration line which is causing restriction. Correct kink and repeat step 2.
 4. Turn unit off and time how long it takes high and low pressure gauges to equalize.
 - If pressure equalization takes longer than 10 minutes, a restriction exists in the capillary tube or drier filter. Go to step 5.
 - If pressure equalization takes less than 10 minutes, system is not restricted. Check for other possible causes of malfunction.
 5. Recover refrigerant in sealed system'
- NOTE:** Before opening any refrigeration system, capture refrigerant in system for safe disposal.
6. Remove power from unit.

CAUTION To reduce risk of personal injury or property damage, take necessary precautions against high temperatures required for brazing.

7. Remove and replace restricted device.
8. Evacuate sealed system.
9. Charge system to specification.

NOTE: Do not use captured or recycled refrigerant in Viking units. Captured or recycled refrigerant voids any Viking and /or compressor manufacturer's warranty

NOTE: Charge system with exact amount of refrigerant. See Technical Sheet or refer to unit nameplate for correct refrigerant charge. Inaccurately charged system will cause future problems

Evacuation and Charging

CAUTION To avoid risk of fire, sealed refrigeration system must be air free. To reduce risk of air contamination, follow evacuation procedures exactly.

NOTE: Before opening any refrigeration system, EPA regulations require refrigerant in system to be captured for safe disposal.

Proper evacuation of sealed refrigeration system is an important service procedure. Usable life and operational efficiency greatly depends upon low completely air, moisture and other non-condensables are evacuated from sealed system.

Air in sealed system causes high condensing temperature and pressure, resulting in increased power requirements and reduced performance.

Moisture in sealed system chemically reacts with refrigerant and oil to form corrosive hydrofluoric and hydrochloric acids. These acids attack motor windings and parts, causing premature breakdown.

Before opening system, evaporator coil must be at ambient temperature to minimize moisture infiltration into system.

Evacuation

To evacuate sealed refrigeration system:

1. Connect vacuum pump. Vacuum tight manifold set with tight vacuum hoses, thermocouple vacuum gauge and charging cylinder as shown in illustration. Evacuation should be done through I.D. opening of tubes not through line piercing valve.

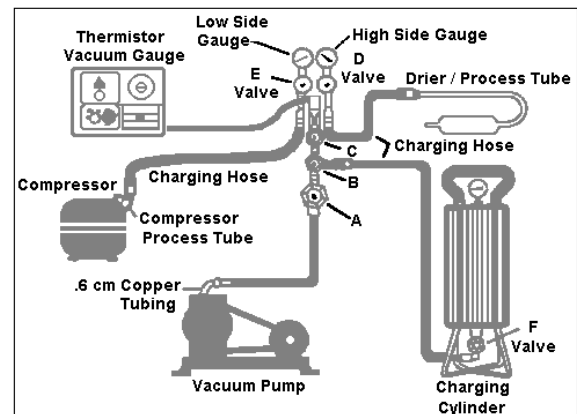

Service Procedures

Evacuation (continued)

2. Connect low side line to compressor process tube.
3. Connect high side line to drier / process tube.
4. Evacuate both simultaneously. With valve "C" and "F" closed, open all other valves and start vacuum pump.
5. After compound gauge (low side) drops to approximately 29 inches gauge, open valve "C" to vacuum thermocouple gauge and take micron reading.
6. Continue evacuating system until vacuum gauge registers 600 microns.
7. At 600 microns, close valve "A" to vacuum pump and allow micron reading in system to balance. Micron level will rise.
 - If in 2 minutes, micron level stabilizes at 1000 microns or below, system is ready to be charged.
 - If micron level rises above 1000 microns and stabilizes, open valve "A" and continue evacuating.
 - If micron reading rises rapidly and does not stabilize, a leak still exists in system.

Close valve "A" to vacuum pump and valve "C" to vacuum gauge. Invert charging cylinder and open charging cylinder valve "F" to add partial charge for leak checking. With leak detector, check manifold connections and system for leaks. After locating leak, capture refrigerant, repair leak, and begin at step 1.

Charging

NOTE: Do not use captured or recycled refrigerant in Viking units. Captured or recycled refrigerant void any warranty.

NOTE: Charge system with exact amount of refrigerant. See Technical Sheet or refer to unit serial plate for correct refrigerant charge. Inaccurately charged system will cause future problems.

To charge system:

1. Close valves "A" to vacuum pump and "C" to vacuum gauge and "E" to low side manifold gauge.
2. Set scale on dial-a-charge cylinder for corresponding HFC134a pressure reading.
3. Open valve "F" to charging cylinder and let exact amount of refrigerant flow from cylinder into system. Close valve.

Low side gauge pressure should rise shortly after opening charging cylinder valve as system pressure equalized through capillary tube.

If pressure does not equalize, a restriction typically exists at capillary/drier braze joint.

4. If pressure equalizes, open valve "E" to low side manifold gauge and pinch off high side drier process tube.
5. Start compressor and draw remaining refrigerant from charging hoses and manifold into compressor through compressor process tube.
6. To check high side, pinch off drier process tube. Close valve "D" to high side gauge. If high side pressure rises, repeat high side pinch off and open valve "D". Repeat until side pinch off does not leak.
7. Pinch off compressor process tube and remove charging hose. Braze stub closed while compressor is operating.
8. Disconnect power. Remove charging hose and braze high side drier process tube closed.
9. Recheck for refrigerant leaks.

Refrigerant Charge

Refrigerant charge in all capillary tube system is critical and exact amount is required for proper performance. Factory charges are shown on serial plate. Do not use refrigerant other than shown on serial plate.

HFC134a Service Information

To minimize risk of contamination which can cause property damage, exercise extreme care when servicing R134a sealed systems

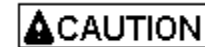

- No trace of other refrigerant is allowed in HFC134a systems. Chlorinated molecules in other refrigerants such as CFC12, etc. will lead to capillary tube plugging.
- Ester oil is used in HFC134a systems. Do not use mineral oil. HFC134a and mineral oils cannot be mixed. If mineral oils were used in HFC134a systems, lubricant would not return to compressor and would cause early compressor failure. If significant amount of oil has been lost from compressor, replace oil rather than adding oil.
- Ester oils used in HFC134a systems are so hydroscopic that by the time an adequate system performance is detected, oil will be saturated with moisture.
- CFC12 has much higher tolerance to system processing materials, such as drawing compounds, rust inhibitors, and cleaning compounds, than HFC134a. Such materials are not soluble in HFC134a systems. If materials were to be washed from system surfaces by ester oils, they could accumulate and eventually plug capillary tube

Service Procedures

HFC134a service Information (continued)

- Care must be taken to minimize moisture from entering HFC134a system. Do not leave compressor or system open to atmosphere for more than 10 minutes. Excessive moisture in HFC134a system will react with compressor oil and generate acid.
- Compressor must be replaced when performing low side leak repair..
- Drier filter must always be replaced with service drier filter. **Important:** Un-brazing drier filter from tubing will drive moisture from desiccant and into system, causing acids to form. Do not un-braze filter drier from tubing. If CFC12 service drier was installed in HFC134a system, drier could overload due to excessive moisture.
- HFC134a compatible copper tubing must be used when replacing tubing.
- Avoid system contamination by using an evaporating oil when flaring, swagging, or cutting refrigeration tubing.

HFC134a is alternative for CFC12.

HFC134a has an ozone depletion potential (ODP) factor of 0.0 and a global warming potential (GWP) factor of 0.27. HFC134a is not flammable and has acceptable tonicity levels. HFC134a is not interchangeable with CFC12. there are significant differences between HFC1134a and CFC12 which must be considered when handling and processing refrigerant system.

Comparison of CFC12 AND HFC134a Properties

Properties / Characteristics	CFC12	HFC134a
Ozone Depletion Potential	1.0	0.0
Global Warming Potential	3.2	0.27
Molecular Weight	121	102
Boiling Point at 1 Atmosphere	-22 F (-30 C)	-15 F (-126 C)
Vapor Pressure at 77 F (25 C)	80 psig	82 psig
Liquid Density at 77 F (25 C)	82 lb/ft	75 lb/ft
Flammability	No	No
High-side System operating Pressure at 65 F (18 C)	HFC134a approximately 3 psig Higher than CFC12	
Low-side System operating Pressure at 65 F (18 C)	HFC134a approximately 2 psig Lower than CFC12	

Health, Safety, and Handling

Health, safety, and handling considerations for HFC134a are virtually no different than those for CFC12.

Health, Safety, and Handling	CFC12	HFC134a
Allowable overall exposure limit	1,000ppm	Same
Vapor exposure to skin	No effect	Same
Liquid exposure to skin	Can cause frostbite	Same
Vapor exposure to eye	Slight eye irritant	Same
Liquid exposure to eye	Can cause frostbite	Same
Above minimum exposure limit	Can cause Asphyxiation, Tachycardia, and Cardia Anthythmia	Same
Safety and handling	Wear appropriate skin and eye protection. Use with adequate ventilation.	Same
Spill management	Remove or extinguish ignition or combustion sources. Evacuate or ventilate area.	Same
Fire explosion hazards	May decompose if contact with flames and heating elements. Container may explode if heated due to resulting pressure rise. Combustion products are toxic.	Same
Disposal procedures	Recycle or reclaim	Same

Replacement Service Compressor

HFC134a service compressor will be charged with ester oil and pressurized with dry nitrogen. Before replacement compressor is installed, pull out 1 rubber plug. A pop from pressure release should be heard. If a pop sound is not heard, do not use compressor. Positive pressure in compressor is vital to keep moisture out of ester oil. Do not leave compressor open to atmosphere for more than 10 minutes.

Compressor Testing Procedures



To avoid death or severe personal injury, never use oxygen, air or acetylene for pressure testing or clean out of refrigeration system. Use of oxygen, air or acetylene may result in violent explosion. Oxygen may explode on contact with oil and acetylene will spontaneously explode when under pressure.

Refer to Technical Date Sheet “Temperature and Relationship Chart” for operating watts, test points, and temperature relationship test for unit being tested

- Temperature testing is accomplished by using 3 lead thermocouple temperature tester in specific locations. Test point “T-1” is outlet on evaporator coil and “T-2” inlet. Test point”T-3” is suction tube temperature midway between where armafex ends and suction port of compressor (approximately 12 inches from compressor).

Service Procedures

Replacement Service Compressor (continued)

- Thermocouple tips should be attached securely to specific locations.
- Do not test during initial pull down. Allow one off cycle or balanced temperature condition to occur before proceeding with testing.
- Refrigerator must operate minimum of 20 minutes after thermocouples are installed.
- Turn control to colder to obtain required on time.
- Wattage reading must be recorded in conjunction with temperature test to confirm proper operation.
- Suction and head pressure are listed on "Temperature and Relationship Chart". Normally these are not required for diagnosis but used for conformation on system which have been opened.

Brazing

CAUTION To reduce risk of personal injury or property damage, take necessary precautions against high temperature required for brazing.

Satisfactory results require cleanliness, experience, and use of proper materials and equipment.

Connections to be brazed must be properly sized, free on rough edges, and clean.

Generally accepted brazing materials are:

- **Copper to copper joints;** SIL-FOS (alloy of 15% silver, 80% copper, and 5% phosphorous). Use without flux. Recommended brazing temperature is approximately 1400°F. **Do not use for copper to steel connection.**
- **Copper to steel joints;** SILVER SOLDER (alloy of 30% silver, 38% copper, 32% zinc). Use with fluoride based flux. Recommended brazing temperature is approximately 1200°F.
- **Steel to steel joints;** SILVER SOLDER (See copper to steel joints.)
- **Brass to copper joints;** SILVER SOLDER (See Copper to steel joints).
- **Brass to steel joints;** SILVER SOLDER (See copper to steel joints).

Checking Electric Heater Assembly

1. Disconnect power to unit.
2. Ensure heater element is cold, then remove suspect heater visually inspect element for obvious damage (breaks, cracks in element, etc.)

3. Attach ohmmeter to element leads. Check for continuity (see tech sheet for unit under test).

If element reads open (infinite or very high resistance): replace element.

4. Check disc type thermostat for continuity (see tech sheet for open and closed values). If open, replace.

Door stop adjustment:

1. Remove center grille blade from top air grille.
2. Remove top air grille by removing (4) 1/4" screws with magnetic screwdriver. Pull assembly forward.]
3. Open refrigerator door so door stop arm and shoulder screw are accessible. Shoulder screws should be in 110° door opening position.
4. Remove shoulder screw and place shoulder screw in the 90° or 120° door opening position.

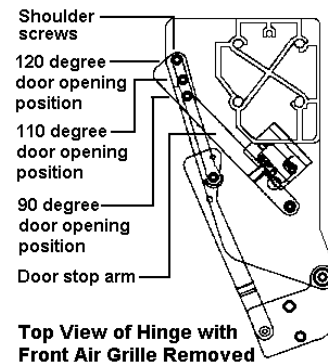

Hinge adjustment:

Verify proper door alignment. Wait until panels are installed for door settlement. Only the top hinge is adjustable.

Adjust top hinge by completing the following:

1. Remove air grille blade and air grille assembly.
2. Loosen top hinge screws.

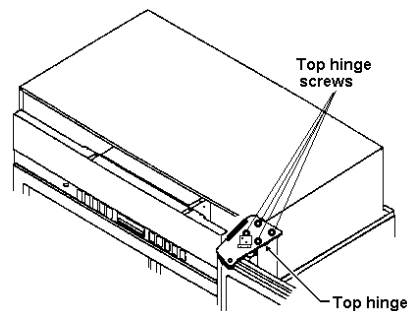

3. Align refrigerator door by lifting.
4. Tighten screws.
5. Install air grille.
6. Replace air grille assembly.

Refrigerant Flow

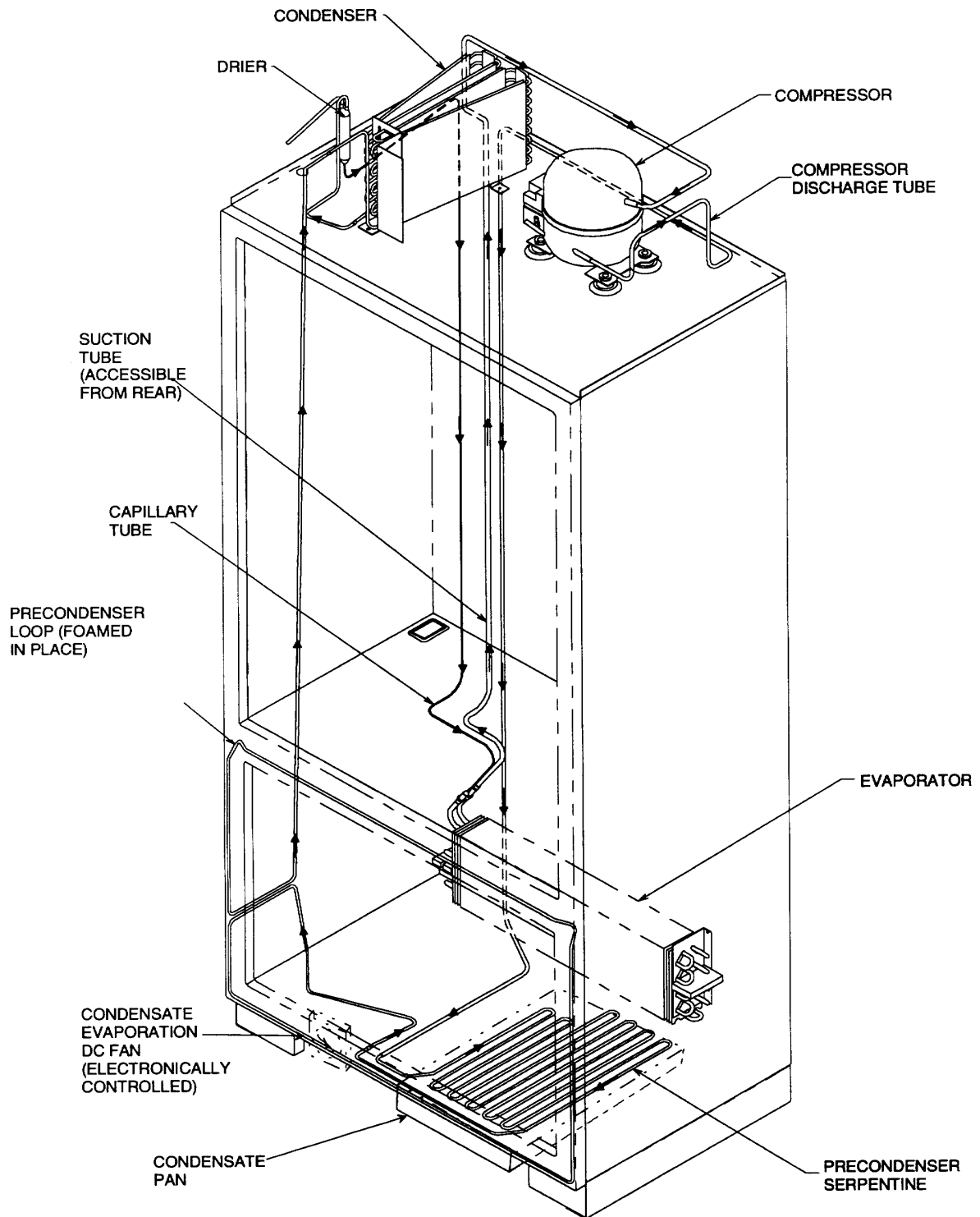

Cabinet Air Flow

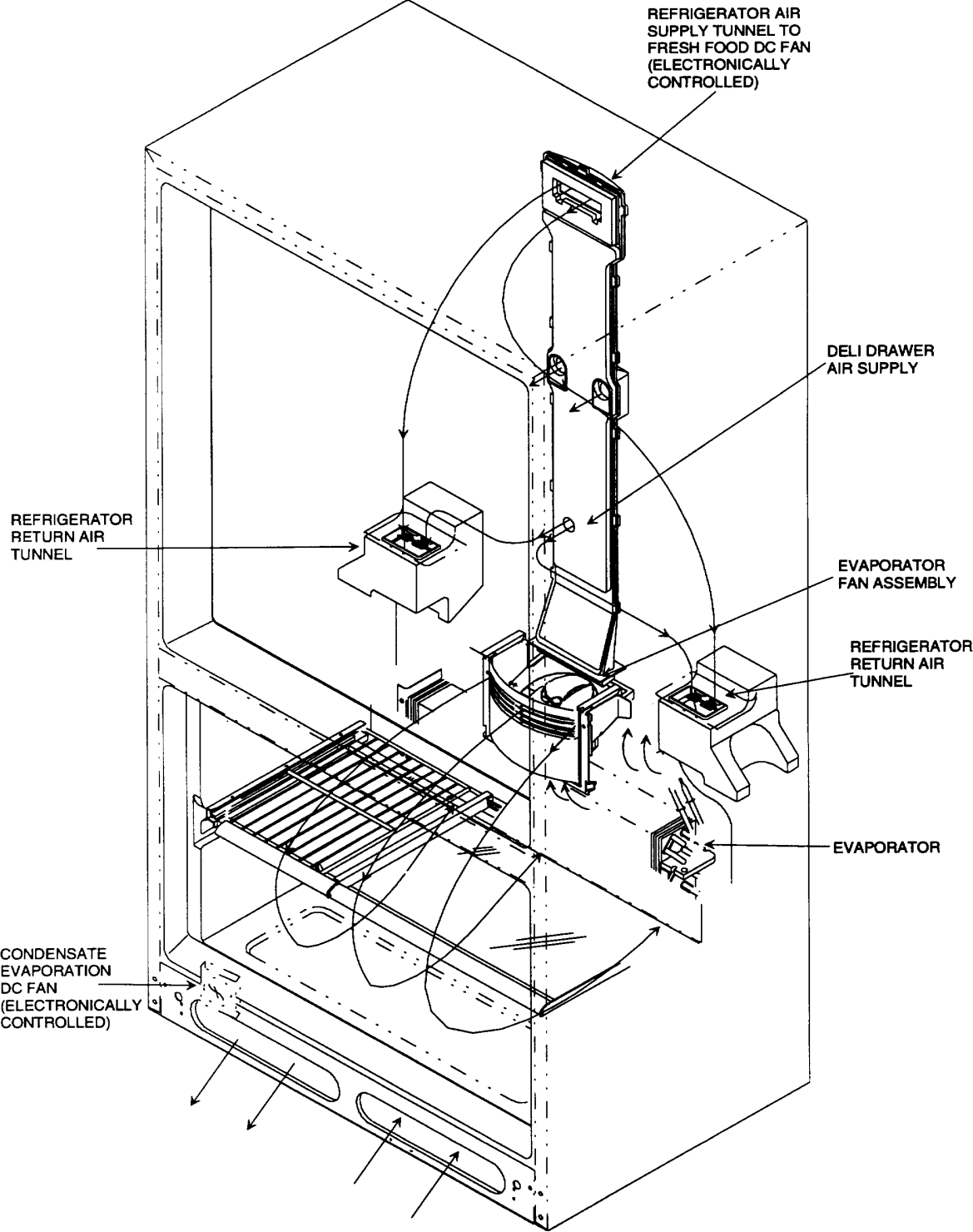

Machine Compartment Air Flow

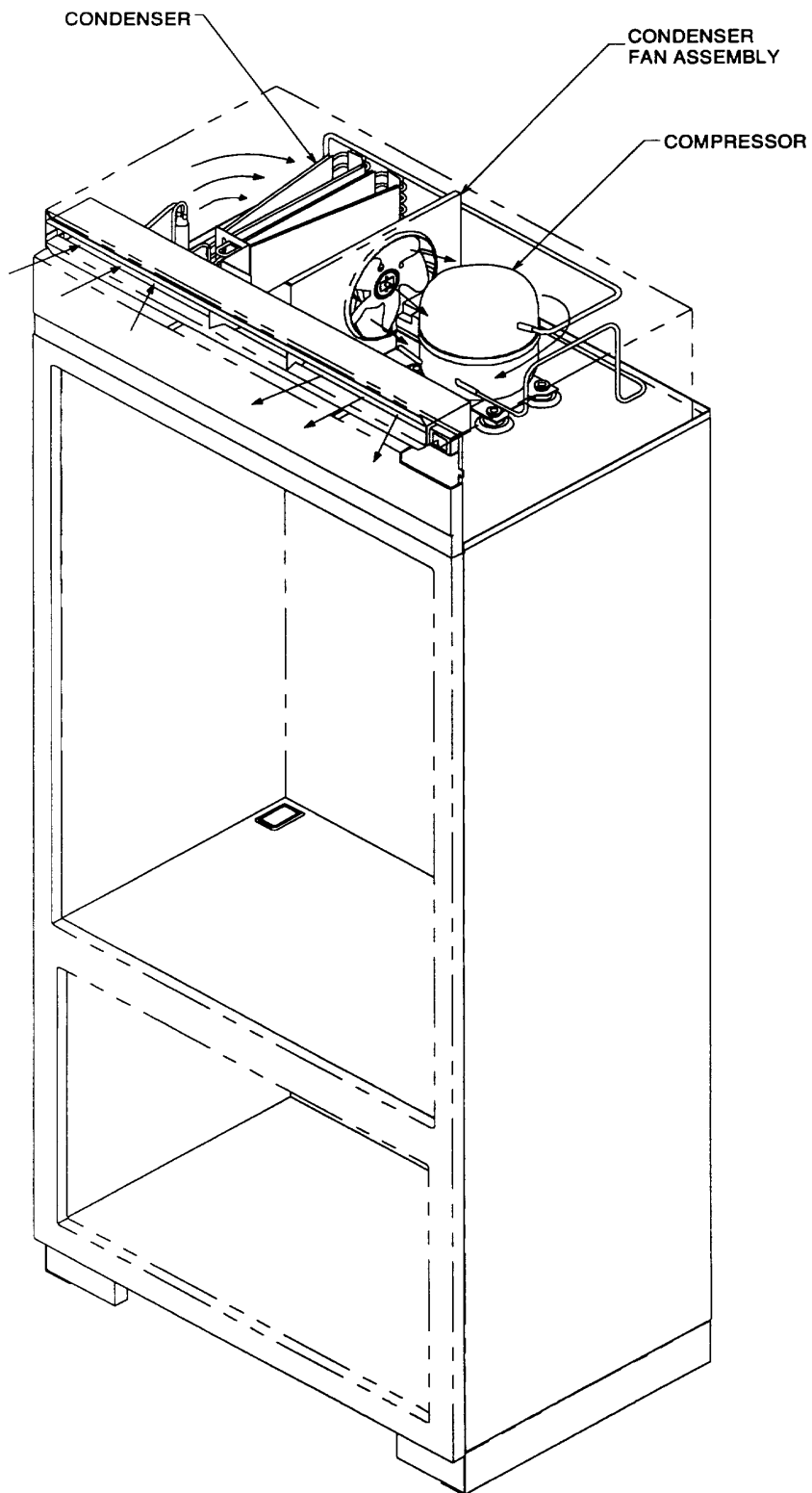

Typical External Sweat Pattern

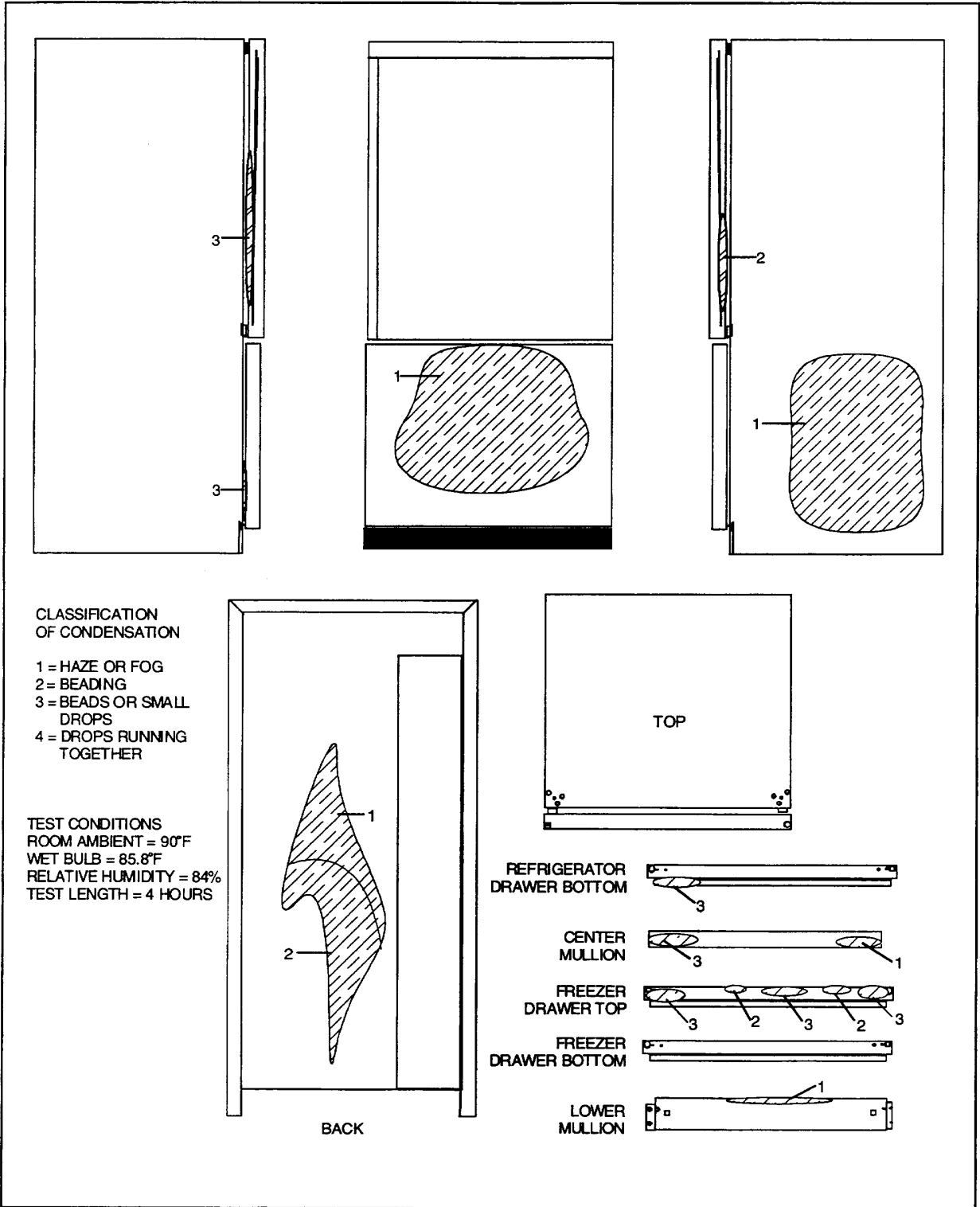

Disassembly Procedures

Door Components

Air Discharge Grille

1. Remove center vane.
NOTE: During reassembly replace vane with curve up, curved/notches end first.
2. Remove 4 screws.
3. Pull grille assembly forward.

Refrigerator Door

 To avoid personal injury or property damage, two people are required for door removal.

1. Remove grille.
2. Turn power switch off.
3. Remove glide pin screw (torx #15M) from underside of top door hinge pin plate.
4. Loosen four 3/8" bolts enough to raise upper hinge plate to clear door hinge pin.
5. Lift door off of center hinge plate.
6. Remove door.

Freezer Drawer and Basket

Pull forward

Door Stops

1. Remove air discharge grille.
2. Remove two #15 torx screws.

Door Handles

1. Pry off screw trim. New trim will be required for reassembly.
2. Remove 6 screws on freezer door and 9 screws on refrigerator door, using a Phillips screwdriver.

Door Gaskets

1. Gently pull gasket away from door liner.
2. Reinstall beginning in bottom corner, working up. Align raised portion of gasket into liner track and apply pressure.

Inner Door Liner and Outer Door Shell

Replace complete door assembly.

Refrigerator Door Switch

1. Remove air discharge grille.
2. Remove two #1 point Phillips screws with an offset ratchet tool.

Cabinet Components

Refrigerator Fan

1. Remove air grille caps.
2. Remove air grille by removing four 1/4" hex head screws.
3. Disconnect leads
4. Remove fan by removing 1/4" hex head screws.

Refrigerator Light Switch

An offset or ratchet #1 point Phillips driver is required

1. Remove air discharge grille.
2. Remove 2 Phillips screws securing switch to top door hinge.

Refrigerator Light Socket

1. Remove cover by removing four 1/4" hex head shoulder screws and sliding cover to rear.
2. Remove bulbs.
3. Remove four 1/4" hex head screws on light socket housing. Uncap front and drop down.
4. Pry socket through housing.
5. Remove wiring.

Center Mullion

Center mullion is not replaceable.

Service Mullion Heater

Heater is connected by servicer to spare wire in harness. See Component Testing for connection procedures. Heater is not replaceable.

Freezer Switches and Thermistor Panel

1. Remove screw retaining assembly to evaporator cover.
2. Remove leads.
3. Pry switch assemblies from cover.
4. Remove thermistor by removing 2 screws

Freezer Evaporator Cover

1. Remove freezer shelf, freezer basket, ice service rack, icemaker, switch, and thermistor mounting plate.
2. Remove four 1/4" hex head evaporator cover mounting screws.
3. Push icemaker electrical block through opening in panel. Remove panel.

Defrost Thermostat

1. Uncap thermostat from outlet on evaporator coil.
2. Disconnect orange and brown leads.

Evaporator Defrost Heater

1. Complete steps 1 – 3 of evaporator coil removal.
2. Tip bottom of evaporator coil out.
3. Remove 2 clips.
4. Slide heater down and out from coil.
5. Unplug heater leads.

Important: When reassembling, verify air diverter strips have been reinstalled properly.

Disassembly Procedures

Evaporator

Reclaim refrigerant before proceeding with evaporator removal. To avoid refrigeration system contamination, do not leave refrigeration system or compressor open for more than 10 minutes.

1. Remove freezer switch and thermostat cover.
2. Remove evaporator cover
3. Remove one ¼" hex head screw from left of coil and 2 from right side.
4. Remove defrost thermostat.
5. Remove defrost heater.
6. Shield interior from heat source and un-braze suction tube at evaporator.
7. Score and break capillary tube at inlet to evaporator coil.

Evaporator Fan Blade

1. See Evaporator Fan Motor steps 1-4.
2. Pull fan blade off motor shaft. When replacing fan blade, ½" of motor shaft should extend through hub of fan blade.

Evaporator Fan Motor

1. Remove air discharge grille
2. Remove two 5/16" hex head screws from evaporator fan motor mounting bracket.
3. Maneuver motor / bracket from housing.
4. Remove lead and ground wires.
5. Remove two ¼" hex head screws from brackets.

Toe Grille

1. Remove two ¼" hex head screws
2. Pull forward

Front and Rear Roller Assembly

Refrigerator cannot be installed when replacing roller assembly.

1. Remove toe grille.
2. Raise front of refrigerator 4" (101.6mm) from floor.
3. Remove cotter pin from shaft.
4. Remove leveling bolt.
5. Drive pin out from roller assembly and through access hole in cabinet.

Condensate Evaporator Fan

1. Remove toe grille.
2. Remove two ¼" hex head screws holding valve/bracket assembly to fan bracket.
3. Remove two ¼" hex head screws holding fan bracket to left front roller assembly.
4. Unplug fan leads from wiring harness.
5. Remove two bolts at fan corners mounting fan on bracket.

Water Valve

1. Remove toe grille.
2. Disconnect water supply.
3. Disconnect and remove outlet waterline.
4. Remove two ¼" hex head screws holding valve/bracket to condensate evaporator fan bracket.
5. Unplug wiring harness.

Condensate Drain Pan

Before removing drain pan, have towels ready to absorb condensation.

1. Remove toe grille.
2. Pull pan forward.

NOTE: During reassembly, be sure serpentine is inside drain pan for proper evaporation.

Shelf Support Ladders

1. Remove shelves.
2. Remove four #15 torx screws for each ladder.

Chef's Pantry Assembly

1. Remove drawer by sliding up and out.
2. Remove side support rails by removing three ¼" hex head screws on each side.

Refrigerator Thermistor

1. Remove air grille caps by removing four ¼" hex head screws.
2. Remove thermistor attached to rear of grille with tinnerman clips.

Machine Compartment Components

Machine Compartment Access

1. Remove air discharge grille.
2. Open refrigerator door.
3. Remove machine compartment panel by removing 2 Phillips screws. Door will drop down and be held in place by straps. Ribbon connector must be properly connected when testing.

Low Voltage Board

1. See Low and High Voltage Board Showroom Switch Access.
2. Remove 4 Phillips screws.
3. Disconnect edge connector from right edge of board.

Disassembly Procedures

High Voltage Board

1. See Low and High Voltage Board and Showroom Switch Access.
2. Remove board by squeezing clip tips.
3. Mark location of wiring to showroom switch at top right corner of compartment.
4. Unclip molex plug at right side.
5. Pull board forward.
6. Transfer wiring from old board to replacement board.

IMPORTANT: Always recover refrigerant prior to any sealed system component repair or replacement. Replace drier when performing a sealed system repair

Compressor, Condenser, and Condenser Fan Access

1. See Machine Compartment Access.
2. Unplug ribbon connector.
3. Remove two 1/4" hex head screw retaining straps for control panel.
4. Remove control panel.
5. Unplug thermistor 3 pin lead.
6. Unplug 12 pin high voltage molex plug.
7. Remove four 1/4" hex head screws that retain low / high voltage compartment box to floor of machine compartment.
8. Remove low / high voltage compartment.

Capacitor

 **WARNING** To avoid electrical shock which can cause death or severe personal injury discharge capacitor through a resistor before handling.

1. See Compressor, Condenser, Condenser Fan Access.
2. Remove one 1/4" hex head screw from capacitor cover.

Overload and Relay

1. See Compressor, Condenser, Condenser Fan Access.
2. Remove terminal cover by springing plastic clip.

Condenser Fan Blade

1. See Compressor, Condenser, Condenser Fan Access.
2. Remove nut from motor shaft.
3. Remove fan blade. Replace rubber washer behind fan blade when reassembling.

Condenser Fan Motor

1. See Condenser Fan Blade.
2. Remove three 1/4" hex head screws retaining shroud to machine compartment.

3. Access mounting screws by rotating shroud front to right.
4. Remove three 1/4" hex head screws.
5. Unplug 2 pin wire harness.

Pre-condenser Pan Loop

1. Remove toe grille
2. Remove drain pan.
3. Remove "P" clamp from inlet / outlet ends of drain pan loop.
4. Un-braze inlet and outlet tube joints at front left corner, next to water valve. Protect adjoining surfaces from heat source.

Compressor

Always replace drier when repairing refrigeration system. Wear eye protection.

1. See Compressor, Condenser, Condenser Fan Access.
2. See Overload and Relay.
3. Remove four 7/16" hex head shoulder bolts mounting compressor to machine compartment floor.
4. Un-braze suction and discharge tubing from compressor.

Condenser

1. See Compressor, Condenser, Condenser Fan Access.
2. See Condenser Fan Motor, steps 1-3.
3. Remove three 1/4" hex head screws that mount condenser to machine compartment floor.
4. Score capillary tube at drier and break.
5. Un-braze condenser inlet.
6. Slide condenser assembly out.
7. Un-braze 3/16" copper tube from condenser to drier to be reused on replacement condenser and drier.

Power Disconnect Switch

1. See Machine Compartment Access.
2. Remove leads
3. Pop switch out through front.

Showroom Switch

1. See Low and High Voltage Board and Showroom Switch Access.
2. Remove screws and pull switch down.
3. Remove leads.

ICEMAKER

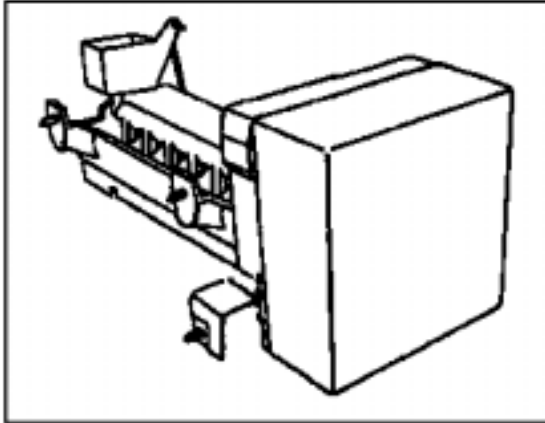

Operation

Thermostat closes when temperature reaches $17^{\circ} \pm 3^{\circ}\text{F}$ ($-8.3^{\circ} \pm 1.5\text{C}$). current flows through thermostat to motor. See "Icemaker Wiring Diagram". Motor is linked with drive gear. From module, there are copper contacts that ride on copper strips on backside of drive gear. As the drive gear rotates, contacts will make or break a circuit (track) to the copper strips to operate icemaker.

All components can be tested without removing icemaker or moving refrigerator away from installation. Remove cover. Test points are identified on Module.

N=Neutral side of line
M=Motor connection
H=Heater connection
T=Thermostat connection
L=L1 side of line
V= Water valve connection

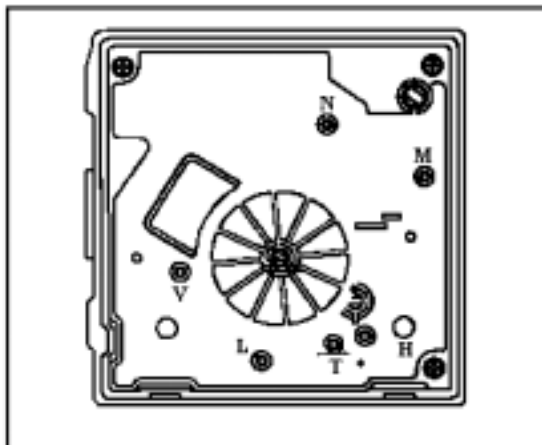

Specifications

Mold Heater	185 watts, 264 ohms
Thermostat (Bimetal)	Close $17^{\circ} \pm 3^{\circ}\text{F}$ ($-8^{\circ} \pm 1^{\circ}\text{C}$) Open $32^{\circ} \pm 3^{\circ}\text{F}$ ($0^{\circ} \pm 1^{\circ}\text{C}$)
Water Fill	140cc, 7.5 seconds
Motor Cycle	Stamped in circuit. Plug in connectors One revolution of blades takes 3 minutes plug stall time on ice (eject and water fill).

Test Procedures

Verify icemaker has power, shut-off arm is down, and freezer is cold enough to close bimetal thermostat.

- Test point L and N will verify 120 volts to icemaker module.
 - Test point T and H will verify bimetal thermostat is open or closed.
 - Verify test probe go into test point $\frac{1}{2}$ " (1.25cm)
1. Short T and H with shunt (insulated 14 gauge wire with ends stripped back $\frac{5}{8}$ " (1.6cm) to run motor. If motor runs, replace bimetal thermostat. If motor does not run, replace module.

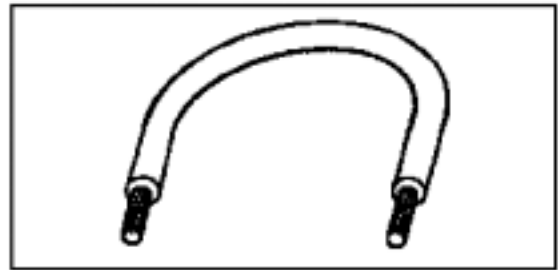

Caution
To avoid icemaker damage do not short any contacts together other than those specified

ICEMAKER

Module Ohmmeter Checks No Power to IceMaker and Ejector Blades in End of Cycle			
Test Points	Component	Module Position	Ohms
L - H	Mold & Heater	Attached to Support	264
L - M	Motor	Separate from Heater	16,100

Module Voltage Checks with Meter or Test Light Power to IceMaker			
L - N	Module	Line Voltage	0 Volts
T - H	Bimetal	Power On	Power Off
L - H	Heater	On	Off
L - M	Motor	On	Off
N - V	Water Valve	On	Off

Disassembly Procedures

Cover

1. Pull water adjustment knob forward.
2. Snap off cover.



Warning

To avoid electrical shock which can cause severe personal injury or death, disconnect power to refrigerator using power switch before servicing. Wires removed during disassembly must be replaced on proper terminals to insure correct grounding and polarization. After servicing reconnect power using power switch.

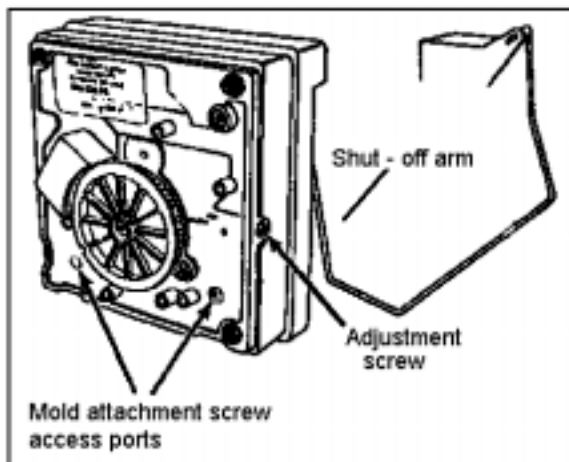

Module, Motor, and Support Assembly

1. Loosen both screws in module access ports.
2. Disconnect shut-off arm.
3. Pull mold from support assembly.

Remove module only by removing 3 screws and pulling module out of housing.

Shut-Off Arm

1. Pull shut-off arm out from white bushing.
2. Replace by pushing completely in.
3. Follow steps below.

Module and Heater Assembly

1. Remove module and support assembly.
2. Install module and support assembly on replacement mold and heater assembly.

Fill Cup

1. Remove module and support assembly
2. Remove ejector blades and shut-off arm.

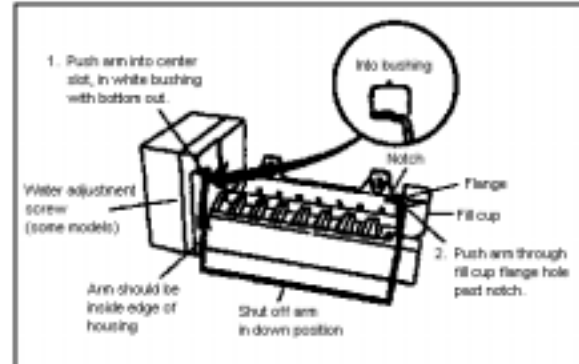

ICEMAKER

Ejector Blades or Stripper

- 1 Remove module and support assembly
- 2 Install ejector blades, realigning "D" coupling with module cam.

Accessing Control Box

1. Remove motor and contact assembly from control box by removing 3 screws.
2. Remove shut-off arm
3. Pull free.

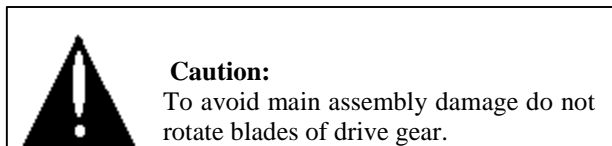
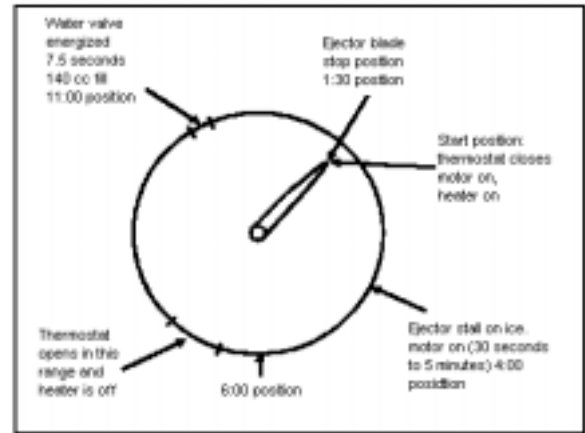
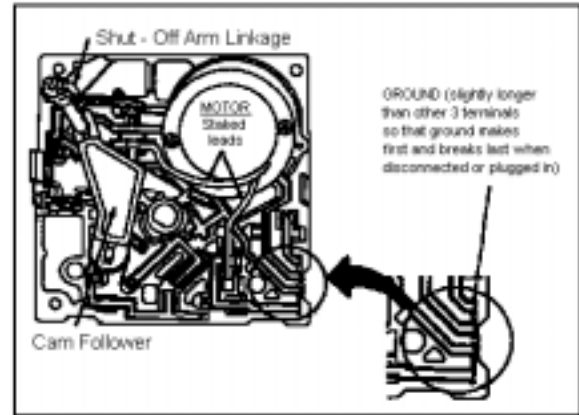
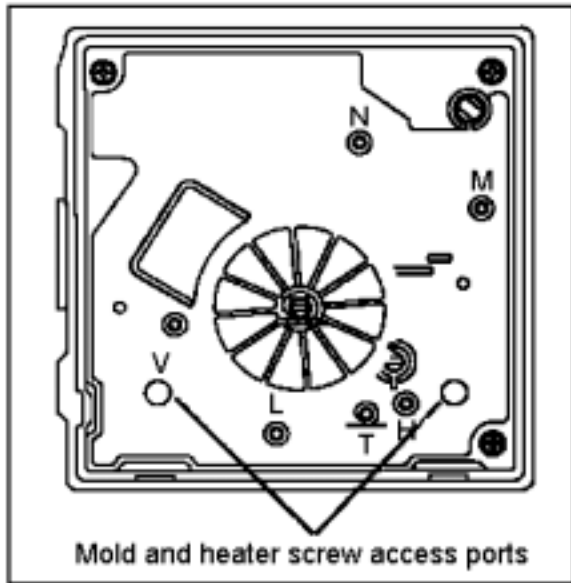

Switches will jam if turned counterclockwise and gears will be destroyed if turned clockwise. Advance icemaker into cycle by using a jumper to bridge H and R. Icemaker will not run if motor is defective. Shut-off arm must be in on position. There are several slotted shafts on motor assembly board. Do not insert screwdriver and attempt to turn shafts. Slots permit assembly only. There are non-repairable and non-replaceable components in module. When diagnosing or repairing icemaker, do not remove module unless replacing module.

Water Fill Adjustment

Turning water level adjustment screw will move contact in relationship with contact ring segment. This causes contact to vary time water valve is energized. Contact ring is tapered at end of fill time.

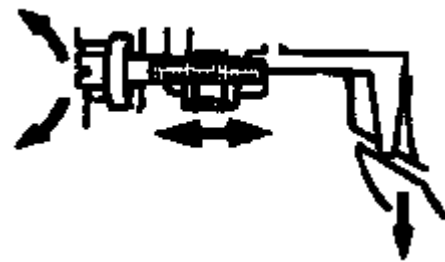

- Turning screw clockwise decreases fill time.
- Turning screw counterclockwise increases fill time
- ½ turn equals 20 cc or 1.2 seconds.
- Full turn equals 40 cc or 2.4 seconds.

ICEMAKER

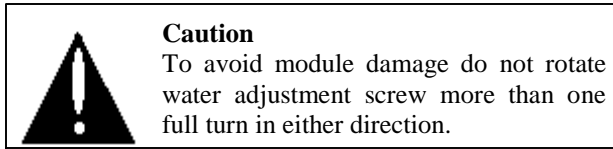

If water valve adjustment screw fall out, put screw in hole and align as shown below.

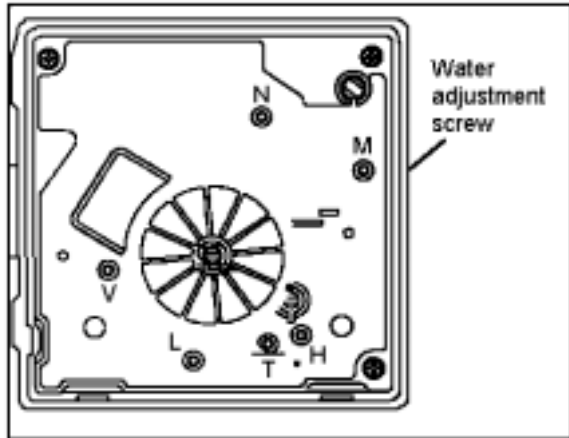

When small hole is centered in large hole, water fill adjustment is 7.5 seconds (normal fill time).

Water Problems

Poor water quality can cause icemaker to fall or produce unacceptable cubes. Mineral content or sand can restrict screen in water fill valve or particle of sand can keep valve from seating properly.

- No ice production
- Small or hollow cubes
- Flooding of ice container

Install water filter to eliminate bad taste, odor and visible contaminates. Mineral contact can cause lime build up in mold. Wicking of water over mold and cube release can occur. Silicone is applied at upper edges around fill cup and stripper.

Temperature Problems

Freezing temperatures above normal $0^{\circ} \pm 2^{\circ}\text{F}$ ($-18^{\circ} \pm 1^{\circ}\text{C}$) will slow down ice production. Increase ice production by setting freezer to coldest setting. Thermostat cycling temperature (1 revolution icemaker) is $17^{\circ} \pm 3^{\circ}\text{F}$ ($-8^{\circ} \pm 1^{\circ}\text{C}$). Ice will freeze when these temperatures are achieved. Cycling time will be slower if freezer temperature is not cold enough to achieve mold temperature easily. Thermostat, mold heater and wiring harness are replaceable. Any other failure, including motor, requires replacement of module assembly.

Replacement mold assembly comes with new mold heater installed.

Thermostat

1. Remove control box from mold by removing screws.

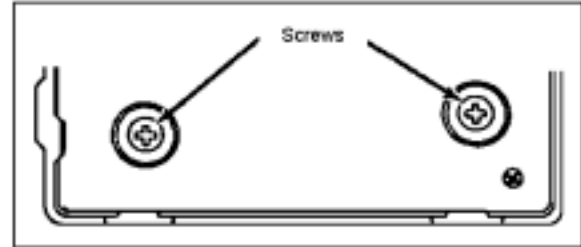

2. Pull front of black housing free of mold. Thermostat is on mold side.

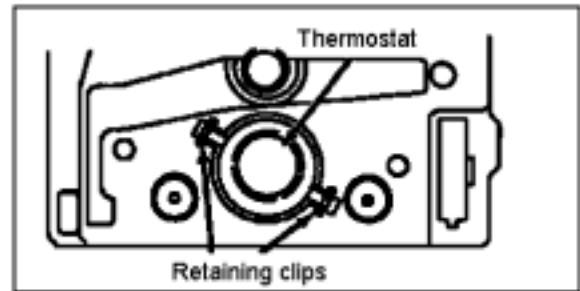

3. Grasp 1 thermostat clip and pull out.
4. Press in new thermostat. Verify pins are properly indexed. Electrical assembly does not need to be removed.

If replacing module, transfer clips to new mold support. Use new thermal bonding material.

Wiring Harness

Remove wiring harness by pressing retaining tab and pulling forward.

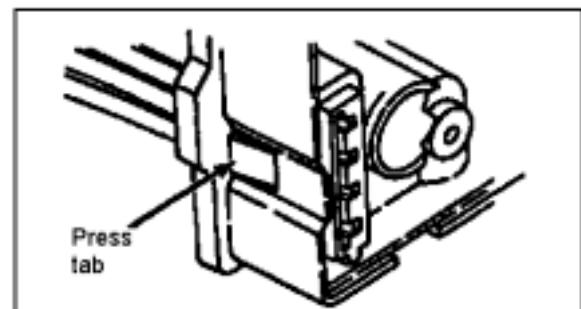

ICEMAKER



To avoid property damage, test for water leaks after repair or replacement of water valve. Do not over tighten connection to household water supply.

Water Valve

Water valve has 1 solenoid. Valve has 80 mesh screen water strainer. When tan encapsulated solenoid is energized, the amount of water entering icemaker mold is directly proportional to length of time water valve switch is held closed by timing cam. Inside valve is a flow washer which acts as a water pressure regulator. Proper icemaker fill is 140cc \pm 10cc at 7.5 seconds of water fill at an inlet pressure ranging from 20 to 120 psi (1.4 to 8.2 bar).

Wire Harness

A non-resettable thermal fuse micro device 170°F (78°C) is spliced into red wire of icemaker wiring harness. Excessive heat can cause no ice production. Replacing wiring harness will only temporarily solve the problem. Replace icemaker thermostats.

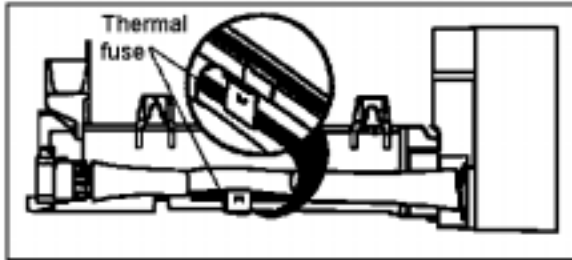

Ice Maker Troubleshooting Chart

No or Low Ice Production	
Problem	Action
Warm freezer	Adjust freezer control or repair refrigerator
Broken locking tab on vertical cam	Replace module
Shorted and burned module shut-off switch and contacts	Replace module
Stalled or stripped motor	Replace module
2:30 Ejector Position	
Contaminated module. Motor won't run when "T" and "H" test points are shorted.	Replace module
Open or missing thermostat	Replace or install thermostat Apply alumilastic
No power to ice maker (harness)	Determine discontinuity by tracing power
Jammed cubes Notice size and density of cubes	Un-jam cubes Check fill tube cup assembly
Frozen fill tube	Replace water valve
Kinked water line	Un-kink line and check line for weak sections
Obstructed water line to ice maker or refrigerator.	Clear water line
Clogged water valve	Replace water valve
No power to water valve Low water pressure	Determine discontinuity by tracing power Short "T" and "H" test points for 10 seconds. Remove jumpers. Catch water in glass. Increase water pressure to 20-120 (1.4-8.2 bar) 140cc's.
Open heater circuit	Replace mold and heater assembly
Closed thermostat	Replace thermostat
Damaged heater tulips on module	Replace module
Short heater pins that do not contact module	Replace mold and heater assembly
Raised shut-off arm	Lower shut-off arm to begin cycle
Water or ice in actuator/housing hole	Remove module Dry actuator and housing hole
Small or burred housing hole	Repair or replace ice maker
Large or burred actuator O.D.	Replace module
Damaged module housing	Replace module
Deformed shut-off arm	Replace shut-off arm
Little or no alumilastic on thermostat	Apply alumilastic to thermostat
Housing to mold screws not seated	Tighten 2 screws (20-26 in.lb) (22.8-29.6 cm.kg)
Heater not staked in mold	Replace mold and heater assembly Apply alumilastics

Ice Maker Troubleshooting Chart

Incorrect heater temperature	Replace mold and heater assembly Apply alumilastic
Broken shut-off lever or mislocated shut-off switch	Replace module
3:00 Ejector Position	
Contaminated	Replace module
Jammed cubes Notice size and density of cubes	Un-jam cubes
Refrigerator or ice maker not level	Level refrigerator or ice maker
No power to ice maker	Determine discontinuity by tracing power
Excessive water-fill volume	Adjust module screw, lower water pressure, or replace water valve
Cubes falling back into mold during ejection Check fill tube assembly	Replace fill cup
4:00 Ejector Position	
Contaminated	Replace mold and heater assembly Apply alumilastic
Thermostat out of calibration	Replace thermostat. Apply alumilastic
Open heater circuit Motor should oscillate	Replace mold and heater assembly Apply alumilastic
Little or not alumilastic on thermostat	Apply alumilastic to thermostat
Heater not staked in mold	Replace mold and heater assembly Apply alumilastic
Broken locking tabs on vertical cam	Replace module
6:00 Ejector Position	
Contaminated	Replace mold and heater assembly Apply alumilastic
Insufficient water to ice maker small or hollow cubes	Refer to "Hollow Ice Cubes"
7:30 Ejector Position	
Contaminated Motor will not oscillate	Replace module
Shut-off arm stuck in ice or obstructed	Remove obstruction Replace module
Cubes not formed properly	Un-Jam Check fill cup and fill tube assembly
9:00 Ejector Position	
Contaminated	Replace module
Cubes frozen to fill cup or mold	Un-Jam Replace fill cup and module

Ice Maker Troubleshooting Chart

Excessive Ice Production	
Problem	Action
Shut-off arm not in actuator	Replace shut-off arm in actuator
Deformed Shut-off arm	Replace shut-off arm
Broken shut-off lever or lever bypassing vertical cam	Replace module
Broken module actuator	Replace module
Hollow Ice Cubes	
Low water fill volume	Adjust module screw, clear water path, or replace water valve
Improper freezer air-flow	Direct air flow away from thermostat
Thermostat out of calibration	Replace thermostat Apply alumilastic
Flooding or Ice in Bucket or Freezer	
Thermostat out of calibration	Replace thermostat Apply alumilastic
Jammed cube stalled in water-fill cycle	Remove cube Determine reason for stall
Leaky water valve	Replace water valve
Excessive water fill volume	Replace water valve
Motor stalled in water-fill cycle (12: ejector position)	Replace module
Contaminated module	Replace module
Refrigerator or ice maker not level	Level refrigerator or ice maker
Excessive water pressure	Decrease water pressure (20-120 psi) (1.4- 8.2bar)
Shorted and burned module shut-off switch and contacts	Replace module
Broken locking tab on vertical cam (Stalled in water fill)	Replace module
Fill-tube not properly positioned in fill cup	Reposition fill tube
Fill cup water opening blocked	Replace fill cup
Cubes fall over back of ice maker, melting in freezer	Replace fill cup

Ice Maker Wiring Diagram and Parts Layout

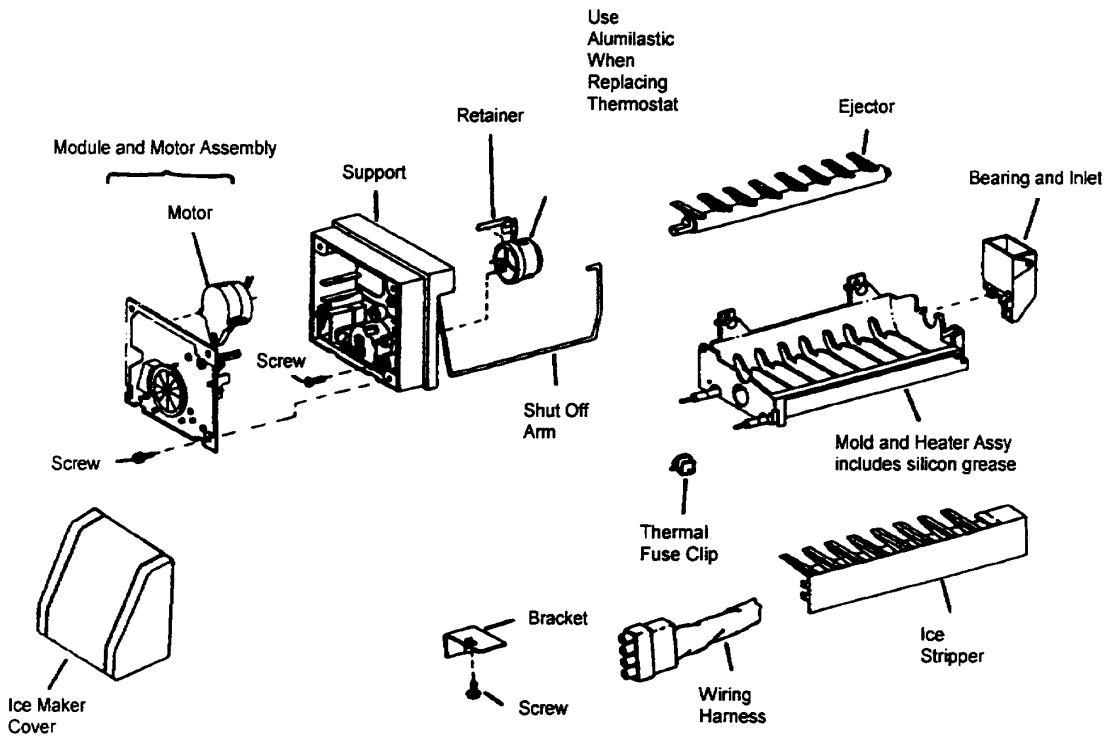
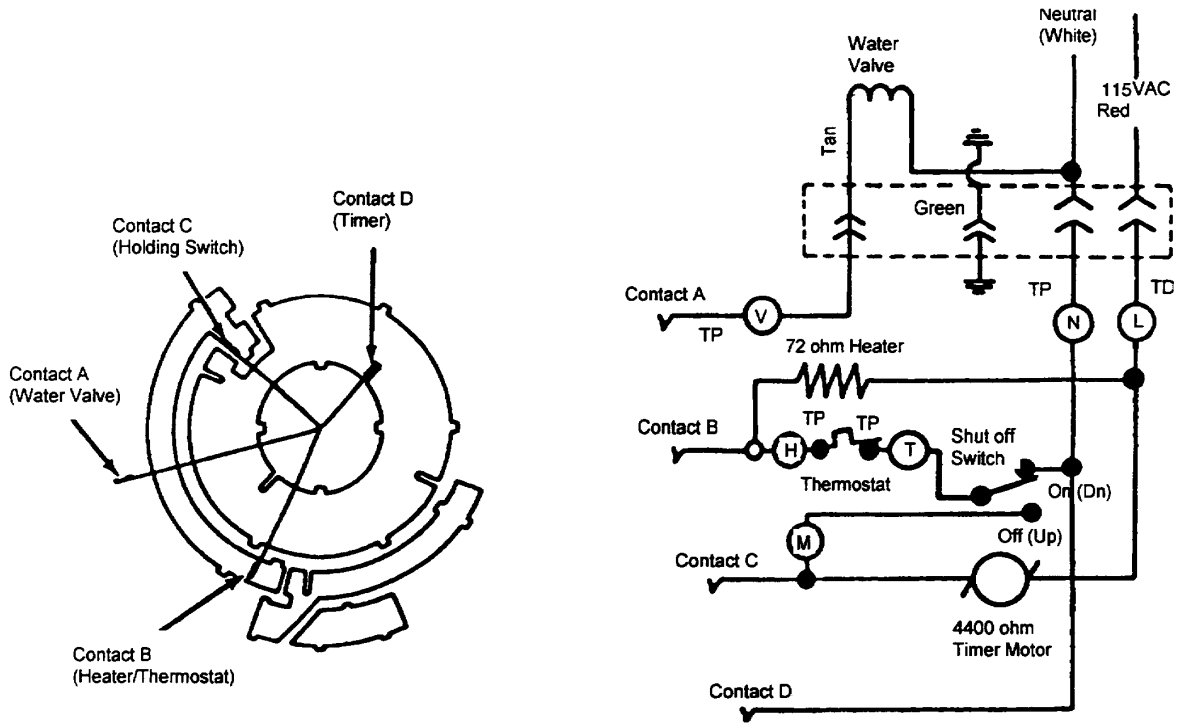

Filename: VCB36055.doc
Directory: D:\VBCODE\IPLUTILS\PDFGenerator\InputData\F90558 VCB360-362
Template: C:\Documents and Settings\tomw.EYECOM\Application
Data\Microsoft\Templates\Normal.dot
Title:
Subject:
Author: Viking Range
Keywords:
Comments:
Creation Date: 10/24/2001 2:09 PM
Change Number: 3
Last Saved On: 3/28/2003 3:54 PM
Last Saved By: Ken Sievert
Total Editing Time: 3 Minutes
Last Printed On: 3/28/2003 6:03 PM
As of Last Complete Printing
Number of Pages: 1
Number of Words: 2 (approx.)
Number of Characters: 17 (approx.)