



CONSUMER SERVICES TECHNICAL  
EDUCATION GROUP PRESENTS

L-78

duet  
sport™

# FRONT-LOADING AUTOMATIC WASHER



MODELS: WFW8300SW, WFW8500SW, WFW8500SR

JOB AID  
Part No. 8178558





**For More Appliance Troubleshooting, Repair Help, & DIY Videos  
Visit  
[ApplianceAssistant.com](http://ApplianceAssistant.com)**

**Note: This Page was not included by Whirlpool Corporation  
ApplianceAssistant.com is not affiliated Whirlpool Corporation  
Whirlpool Corporation in no way endorses ApplianceAssistant.com**

## FORWARD

This Whirlpool Job Aid, “Duet Sport™ Front-Loading Automatic Washer” (Part No. 8178558), provides the technician with information on the installation, operation, and service of the Duet Sport™ Front-Loading Automatic Washer. For specific information on the model being serviced, refer to the “Use and Care Guide,” or “Tech Sheet” provided with the washer.

The Wiring Diagram used in this Job Aid is typical and should be used for training purposes only. Always use the Wiring Diagram supplied with the product when servicing the unit.

## GOALS AND OBJECTIVES

The goal of this Job Aid is to provide information that will enable the service technician to properly diagnose malfunctions and repair the Duet Sport™ Front-Loading Automatic Washer.

The objectives of this Job Aid are to:

- Understand and follow proper safety precautions.
- Successfully troubleshoot and diagnose malfunctions.
- Successfully perform necessary repairs.
- Successfully return the washer to its proper operational status.

WHIRLPOOL CORPORATION assumes no responsibility for any repairs made on our products by anyone other than Authorized Service Technicians.

# TABLE OF CONTENTS

	Page
<b>GENERAL</b> .....	1-1
Washer Safety .....	1-1
Model & Serial Number Designations .....	1-2
Model & Serial Number Label And Tech Sheet Locations .....	1-3
Specifications .....	1-4
<b>INSTALLATION INFORMATION</b> .....	2-1
Installation Requirements .....	2-1
Installation Instructions .....	2-6
<b>PRODUCT OPERATION</b> .....	3-1
Features And Benefits .....	3-1
Washer Use .....	3-3
Washer Care .....	3-12
Troubleshooting .....	3-15
<b>COMPONENT ACCESS</b> .....	4-1
Component Locations .....	4-1
Removing The Console And The Touchpad/LED Assembly .....	4-2
Removing The Central Control Unit .....	4-4
Removing The Water Inlet Valve .....	4-6
Removing The Pressure Switch .....	4-7
Removing The Line Filter & Power Supply Cord .....	4-8
Removing The Detergent Dispenser Assembly .....	4-10
Removing The Detergent Dispenser Motor .....	4-13
Removing The Door Switch Assembly And The Bellows .....	4-14
Removing The Drain Pump .....	4-17
Removing The ECO Valve .....	4-19
Removing The Motor Control Unit .....	4-20
Removing The Temperature Sensor & Heater .....	4-22
Removing The Drive Belt And Motor .....	4-23
Removing An Interlock Switch .....	4-25
Removing The Basket Drive Pulley .....	4-27
Removing The Tub & Basket And Baffle .....	4-28
<b>COMPONENT TESTING</b> .....	5-1
Inlet Valve Solenoids .....	5-1
Pressure Switch .....	5-2
Line Filter .....	5-3
Detergent Dispenser Motor & Switch .....	5-4
Door Switch .....	5-5
Drain Pump .....	5-6
Temperature Sensor & Heater .....	5-7
Drive Motor .....	5-8
Interlock Switch .....	5-8

	Page
<b>DIAGNOSTICS &amp; TROUBLESHOOTING</b> .....	6-1
Diagnostics .....	6-1
Diagnostic Guide .....	6-1
Failure/Error Display Codes .....	6-2
Diagnostic Test .....	6-5
Error History Display .....	6-6
History Overview Test Program .....	6-6
Manual Diagnostic Test .....	6-7
Manual Overview Test Program .....	6-7
Electronic Assemblies - Removal Or Replacement .....	6-8
Washer Care .....	6-9
Troubleshooting Guide .....	6-11
<b>WIRING DIAGRAMS</b> .....	7-1
Washer .....	7-1
Grounding System .....	7-2

# GENERAL WASHER SAFETY

## Your safety and the safety of others is very important.

We have provided many important safety messages in this Job Aid and on the appliance. Always read and obey all safety messages.



This is the safety alert symbol.

This symbol alerts you to potential hazards that can kill or hurt you and others.

All safety messages will follow the safety alert symbol and either the word “DANGER” or “WARNING.” These words mean:

**! DANGER**

**You can be killed or seriously injured if you don't immediately follow instructions.**

**! WARNING**

**You can be killed or seriously injured if you don't follow instructions.**

All safety messages will tell you what the potential hazard is, tell you how to reduce the chance of injury, and tell you what can happen if the instructions are not followed.

# MODEL & SERIAL NUMBER DESIGNATIONS

## MODEL NUMBER

<b>MODEL NUMBER</b>	W	F	W	8	3	00	S	W	0
<b>BRAND</b> W = Whirlpool									
<b>ACCESS</b> F = Front Loading									
<b>PRODUCT</b> W = Washer									
<b>SERIES</b> 5 = Whirlpool Leap    6 = Oasis 7 = 24" Front Load    8 = Mid Line Front Load 9 = Duet Front Load									
<b>PRICE POINT LEVELS (1 - 9)</b>									
<b>TRADE PARTNER ID (00 = BRANDED)</b>									
<b>YEAR OF INTRODUCTION</b> S = 2006, T = 2007									
<b>COLOR CODE</b> T = Biscuit Q = White W = White With Metallic Accent R = White With Metallic (Sport Only)									
<b>ENGINEERING CHANGE (NUMERIC)</b>									

## SERIAL NUMBER

<b>SERIAL NUMBER</b>	HL	T	35	10901
<b>DIVISION RESPONSIBILITY</b> Horizontal Washer Facility, Monterrey, MX				
<b>YEAR OF PRODUCTION</b> T = 2006				
<b>WEEK OF PRODUCTION</b> 35 = 35th Week				
<b>PRODUCT SEQUENCE NUMBER</b>				

# MODEL & SERIAL NUMBER LABEL AND TECH SHEET LOCATIONS

The Model & Serial Number Label and Tech Sheet locations are shown below.

Model & Serial Number Label



Tech Sheet (Behind Lower Access Panel)



# SPECIFICATIONS

Model Number	WFW8300SW	WFW8500SW	WFW8500SR
Model Description	Front Load Washer	Front Load Washer	Front Load Washer
Color	White with Gray Accents	White with Gray Accents	White with Sterling Bright Accents
Capacity (Cu.Ft. IEC)	3.3	3.6	3.6
Temperature Control	ATC - 2	ATC - 4	ATC - 4
Heater	No	Yes	Yes
Sensors	Suds Sensor, NTC (Thermistor), Water Level Sensor	Suds Sensor, NTC (Thermistor), Water Level Sensor	Suds Sensor, NTC (Thermistor), Water Level Sensor
Tumble Speed	Heavy Duty & Normal = 40/35 RPM Gentle = 31 RPM	Heavy Duty & Normal = 40/35 RPM Gentle = 31 RPM	Heavy Duty & Normal = 40/35 RPM Gentle = 31 RPM
Spin Speed	High = 1050 RPM Medium = 800 RPM Low = 600 RPM	High = 1100 RPM Medium = 800 RPM Low = 600 RPM	High = 1100 RPM Medium = 800 RPM Low = 600 RPM
Motor	Variable Speed; 1/4 HP	Variable Speed; 1/4 HP	Variable Speed; 1/4 HP
Voltage	120V	120V	120V
Frequency	60 Hz	60 Hz	60 Hz
Amps	10 Amp	10 Amp	10 Amp
Water Consumption Average DOE (Gallons-Per-Cycle)	12.77	14.1	14.1
Rated Load	15.43 lbs. (7 kg)	17.64 lbs. (8 kg)	17.64 lbs. (8 kg)
Load Pounds	Maximum = 11.7 Average = 7.35 Minimum = 3	N/A	N/A
Height	36.0"	36.0"	36.0"
Install Depth: Min - Max	29.25"	30.00"	30.00"
Width	27"	27"	27"
Product Weight (approx)	242 lbs.	242 lbs.	242 lbs.

# INSTALLATION INFORMATION

## INSTALLATION REQUIREMENTS

### TOOLS AND PARTS

Gather the required tools and parts before starting installation. The parts supplied are in the washer drum.

#### Tools needed for connecting the water inlet hoses

- Pliers (that open to 1-9/16" [39.5 mm])
- Flashlight (optional)

#### Tools needed for installation

- Open end wrenches 17 mm and 13 mm
- Level
- Wood block
- Ruler or measuring tape

#### Parts supplied

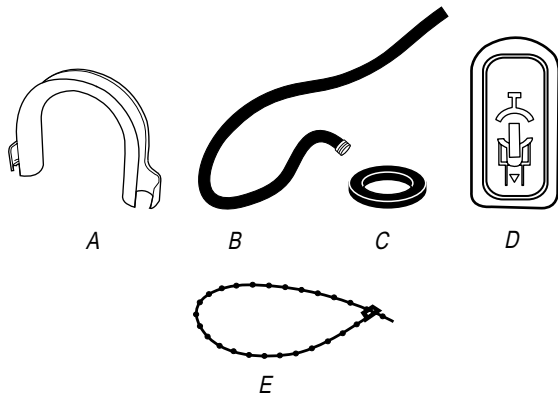

A. U-shaped hose form  
B. Water inlet hoses (2)  
C. Inlet hose washers (4)

D. Transit bolt hole plug  
E. Beaded tie strap

#### Alternate Parts

Your installation may require additional parts. If you are interested in purchasing one of the items listed here, call the toll-free number on the cover or in the "Assistance or Service" section in the "Use & Care Guide."

If You Have	You Will Need to Buy
Laundry tub or standpipe taller than 96" (2.4 m)	Sump pump system (if not already available)
Overhead sewer	Standard 20 gal. (76 L), 30" (76.2 cm) tall drain tub or utility sink and sump pump (available from local plumbing suppliers)
Floor drain	Siphon break, Part Number 285834; additional drain hose Part Number 8318155; and connector kit, Part Number 2858835
Drain hose too short	4 ft (1.2 m) drain hose extension kit, Part Number 2858863
Water faucets beyond reach of fill hoses	2 longer water fill hoses: 6 ft (1.8 m) Part Number 76314 10 ft (3.0 m) Part Number 350008

### OPTIONS

#### Pedestal

You have the option of purchasing pedestals of different heights separately for this washer. You may select a 10" (25.4 cm) or a 15.5" (39.4 cm) pedestal. Remember that the pedestal will add to the total height of the unit.

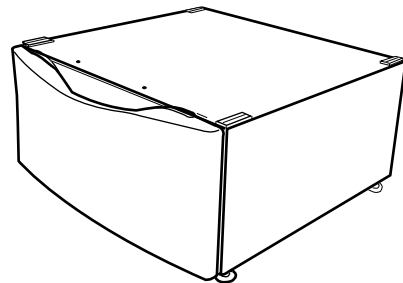

Optional pedestal

Pedestal Height	Approximate Height with Washer	Color	Model Number
10" (25.4 cm)	46" (116.8 cm)	White	WHP1000SQ
15.5" (39.4 cm)	51.5" (130.8 cm)	White	WHP1500SQ

## Stack Kit

Are you planning to stack your washer and dryer? To do so you will need to purchase a Stack Kit.

To order, call the dealer from whom you purchased your dryer or refer to the "Assistance or Service" section in the "Use & Care Guide." Ask for Part Number 8572546.

## LOCATION REQUIREMENTS

Selecting the proper location for your washer improves performance and minimizes noise and possible washer "walk."

The washer can be installed under a custom counter, or in a basement, laundry room, closet, or recessed area. See "Drain System."

Companion appliance location requirements should also be considered. Proper installation is your responsibility.

### You will need

- A water heater set to deliver 120°F (49°C) water to the washer.
- A grounded electrical outlet located within 6 ft (1.8 m) of where the power cord is attached to the back of the washer. See "Electrical Requirements."
- Hot and cold water faucets located within 4 ft (1.2 m) of the hot and cold water fill valves, and water pressure of 20-100 psi (137.9-689.6 kPa).
- A level floor with a maximum slope of 1" (2.5 cm) under entire washer. Installing the washer on soft floor surfaces, such as carpets or surfaces with foam backing, is not recommended.
- A sturdy and solid floor to support the washer with a total weight (water and load) of 400 lbs (180 kg).

Do not operate your washer in temperatures below 32°F (0°C). Some water can remain in the washer and can cause damage in low temperatures.

## Installation Clearances

- The location must be large enough to allow the washer door to be fully opened.
- Additional spacing should be considered for ease of installation and servicing. The door opens more than 90°, and it is not reversible.
- Additional clearances might be required for wall, door, and floor moldings.
- Additional spacing of 1" (2.5 cm) on all sides of the washer is recommended to reduce noise transfer.
- Companion appliance spacing should also be considered.

## Washer Dimensions

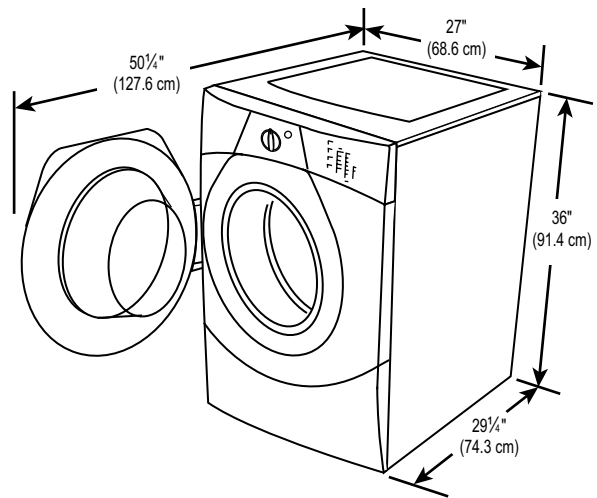

## Recommended installation spacing for custom undercounter installation

The dimensions shown are for the recommended spacing.

### Custom undercounter installation - Washer only

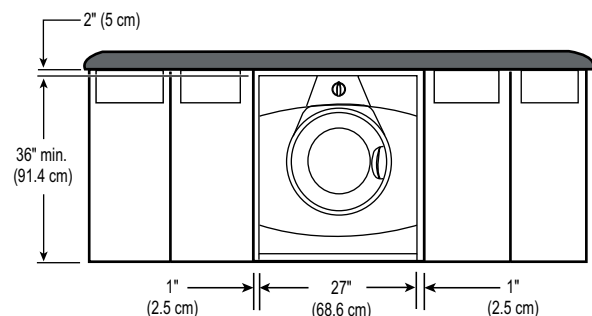

## Recommended installation spacing for recessed or closet installation, with or without a pedestal

The dimensions shown are for the recommended spacing.

### Recessed area or closet installation

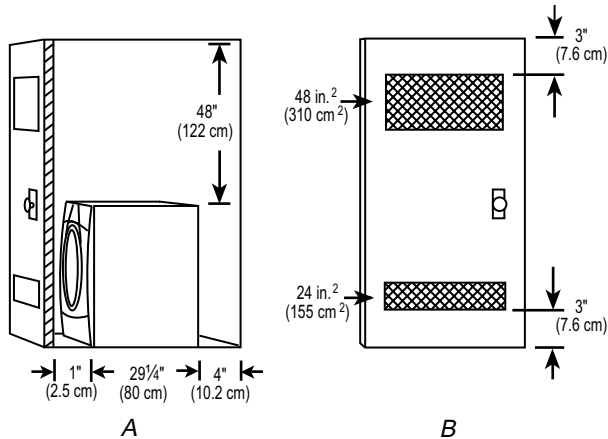

A. Side view - closet or confined area  
B. Closet door with vents

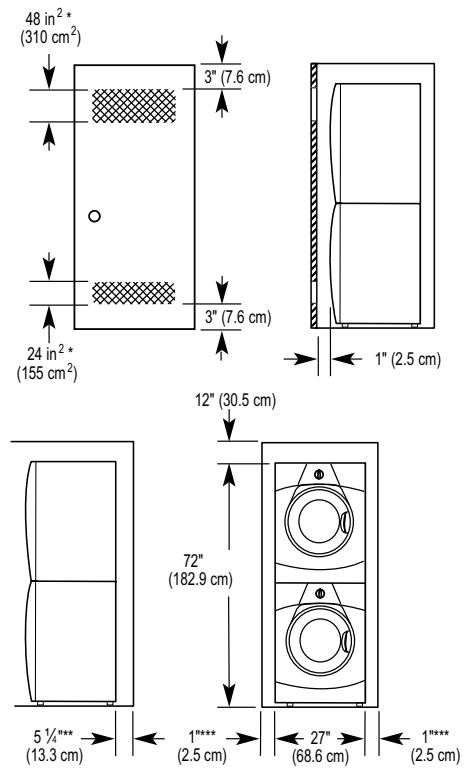

- \* Min. top and bottom air openings for closet door.
- \*\* External exhaust elbow requires additional space.
- \*\*\* Wall, door and floor molding may require additional spacing.

### Recessed or closet installation - Washer on pedestal

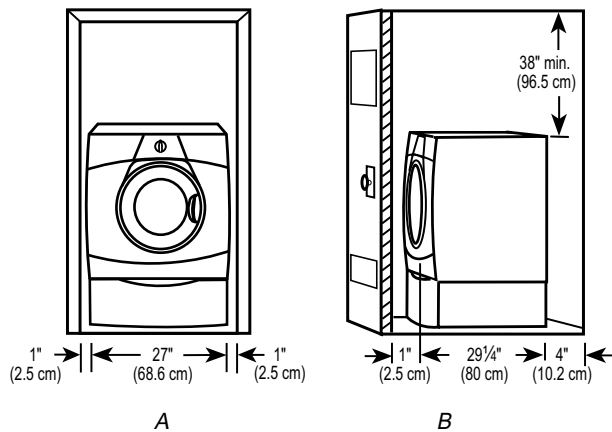

A. Recessed area  
B. Side view - closet or confined area

## Recommended installation spacing for recessed or closet installation, with stacked washer and dryer

The dimensions shown, at the top of the right column, are for the recommended spacing.

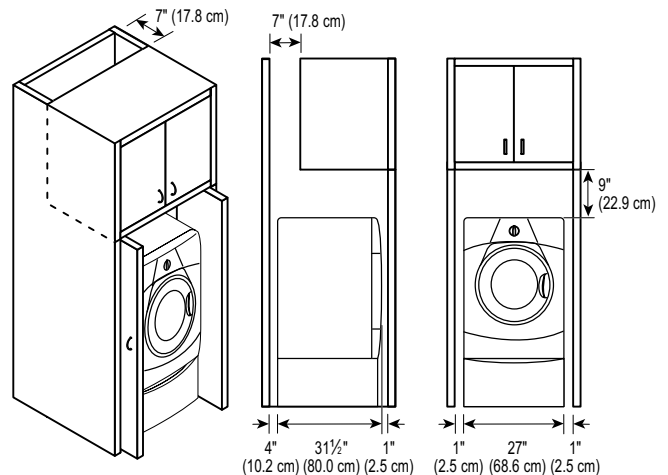

## DRAIN SYSTEM

The washer can be installed using the standpipe drain system (floor or wall), the laundry tub drain system, or the floor drain system. Select the drain hose installation method you need. See “Tools and Parts.”

### Standpipe drain system - wall or floor (views A & B)

The standpipe drain requires a minimum diameter standpipe of 2" (5 cm). The minimum carry-away capacity can be no less than 17 gal. (64 L) per minute.

The top of the standpipe must be at least 30" (76.2 cm) high and no higher than 96" (2.4 m) from the bottom of the washer.

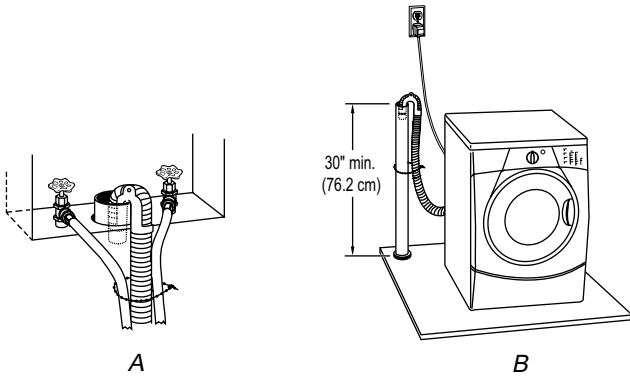

### Laundry tub drain system (view A)

The laundry tub needs a minimum 20 gal. (76 L) capacity. The top of the laundry tub must be at least 30" (76.2 cm) above the floor.

### Floor drain system (view B)

The floor drain system requires a siphon break that may be purchased separately. See “Tools and Parts.”

The siphon break must be a minimum of 28" (71 cm) from the bottom of the washer. Additional hoses might be needed.

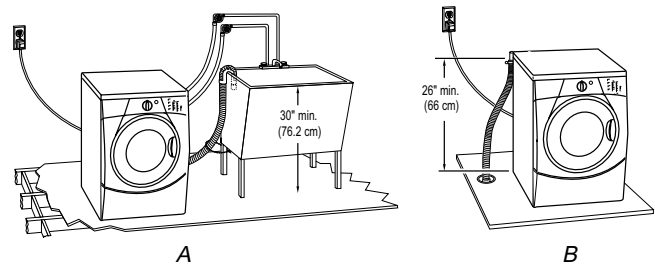

## ELECTRICAL REQUIREMENTS

### **⚠ WARNING**



#### **Electrical Shock Hazard**

**Plug into a grounded 3 prong outlet.**

**Do not remove ground prong.**

**Do not use an adapter.**

**Do not use an extension cord.**

**Failure to follow these instructions can result in death, fire, or electrical shock.**

- A 120 volt, 60 Hz., AC only, 15- or 20-amp, fused electrical supply is required. A time-delay fuse or circuit breaker is recommended. It is recommended that a separate circuit serving only this appliance be provided.
- This washer is equipped with a power supply cord having a 3 prong grounding plug.
- To minimize possible shock hazard, the cord must be plugged into a mating, 3 prong, grounding-type outlet, grounded in accordance with local codes and ordinances. If a mating outlet is not available, it is the personal responsibility and obligation of the customer to have the properly grounded outlet installed by a qualified electrician.
- If codes permit and a separate ground wire is used, it is recommended that a qualified electrician determine that the ground path is adequate.
- Do not ground to a gas pipe.
- Check with a qualified electrician if you are not sure the washer is properly grounded.
- Do not have a fuse in the neutral or ground circuit.

## **GROUNDING INSTRUCTIONS**

### **For a grounded, cord-connected washer:**

This washer must be grounded. In the event of a malfunction or breakdown, grounding will reduce the risk of electrical shock by providing a path of least resistance for electric current. This washer is equipped with a cord having an equipment-grounding conductor and a grounding plug. The plug must be plugged into an appropriate outlet that is properly installed and grounded in accordance with all local codes and ordinances.

**WARNING:** Improper connection of the equipment-grounding conductor can result in a risk of electric shock. Check with a qualified electrician or serviceman if you are in doubt as to whether the appliance is properly grounded.

Do not modify the plug provided with the appliance – if it will not fit the outlet, have a proper outlet installed by a qualified electrician.

### **For a permanently connected washer:**

This washer must be connected to a grounded metal, permanent wiring system, or an equipment-grounding conductor must be run with the circuit conductors and connected to the equipment-grounding terminal or lead on the appliance.

# INSTALLATION INSTRUCTIONS

## REMOVE TRANSPORT SYSTEM

### **⚠ WARNING**

#### **Excessive Weight Hazard**

**Use two or more people to move and install washer.**

**Failure to do so can result in back or other injury.**

**IMPORTANT:** Position the washer so that the rear of the unit is within approximately 3 ft (90 cm) of the final location.

There are 4 bolts in the rear panel of the washer that support the suspension system during transportation. These bolts also retain the power cord inside the washer until the bolts are removed.

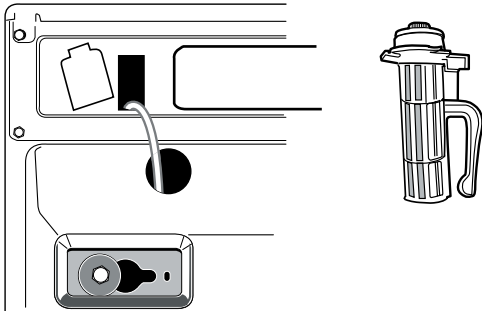

1. Using a 13 mm wrench, loosen each of the bolts.
2. Once the bolt is loose, move it to the center of the hole and completely pull out the bolt, including the plastic spacer covering the bolt.

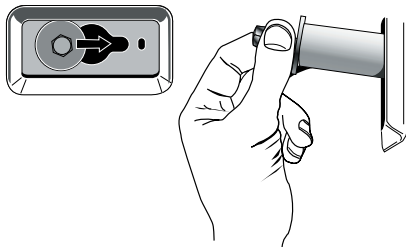

3. Once all 4 bolts are removed, discard the bolts and spacers. Then pull the power cord through the opening of the rear panel and close the hole with the attached cap.

4. Close the bolt holes with the 4 transport bolt hole plugs.

**NOTE:** If the washer is to be transported at a later date, call your local service center. To avoid suspension and structural damage, your machine must be properly set up for re-location by a certified technician.

## CONNECT THE INLET HOSES

Insert new flat washers (supplied) into each end of the inlet hoses. Firmly seat the washers in the couplings.

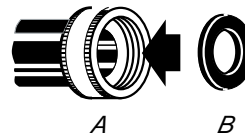

A. Coupling  
B. Washer

## Connect the inlet hoses to the water faucets

Make sure the washer drum is empty.

1. Attach a hose to the hot water faucet. Screw on coupling by hand until it is seated on the washer.
2. Attach a hose to the cold water faucet. Screw on coupling by hand until it is seated on the washer.
3. Using pliers, tighten the couplings with an additional two-thirds turn.

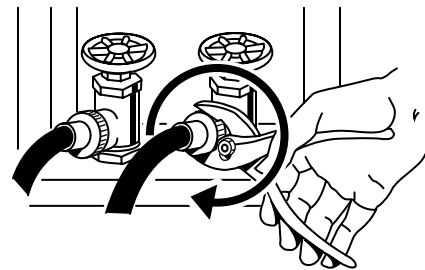

**NOTE:** Do not overtighten or use tape or sealants on the valve. Damage to the valves can result.



## Clear the water lines

1. Run water through both faucets and inlet hoses, into a laundry tub, drainpipe or bucket, to get rid of particles in the water lines that might clog the inlet valve screens.
2. Check the temperature of the water to make sure that the hot water hose is connected to the hot water faucet and that the cold water hose is connected to the cold water faucet.

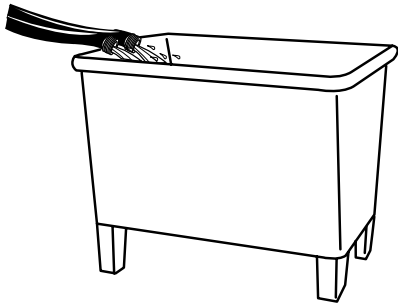

## Connect the inlet hoses to the washer

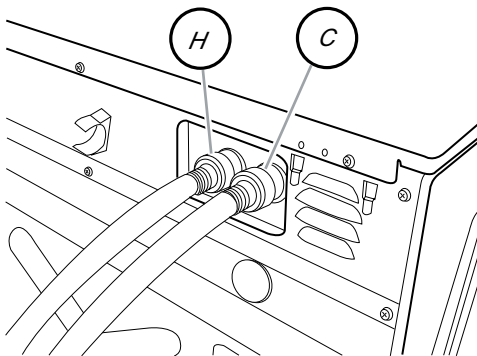

H. Hot water inlet  
C. Cold water inlet

1. Attach the hot water hose to the washer's hot (H) water inlet valve. Screw on coupling by hand until it is seated on the washer.
2. Attach the cold water hose to the washer's cold (C) water faucet. Screw on coupling by hand until it is seated on the washer.
3. Using pliers, tighten the couplings with an additional two-thirds turn.  
**NOTE:** Do not overtighten. Damage to the coupling can result.
4. Turn on the water faucets completely and check for leaks.

**NOTE:** Replace inlet hoses after 5 years of use to reduce the risk of hose failure. Record hose installation or replacement dates on the hoses for future reference.

Periodically inspect and replace hoses if bulges, kinks, cuts, wear, or leaks are found.

## ROUTE THE DRAIN HOSE

Proper routing of the drain hose protects your floors from damage due to water leakage. Read and follow these instructions.

### Remove drain hose from the washer

Gently pull the corrugated drain hose from the shipping clips.

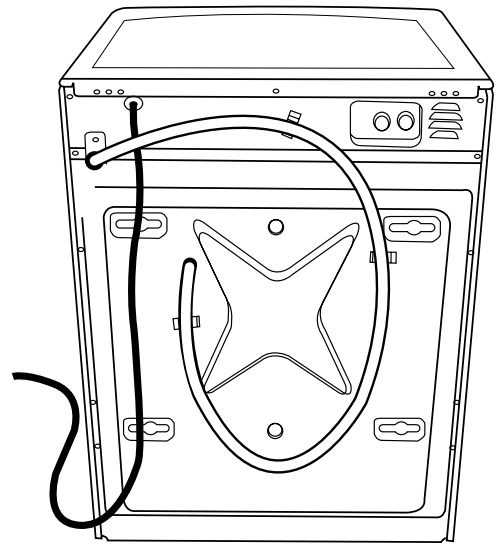

### Laundry tub drain or standpipe drain

Connect the drain hose form to the corrugated drain hose.

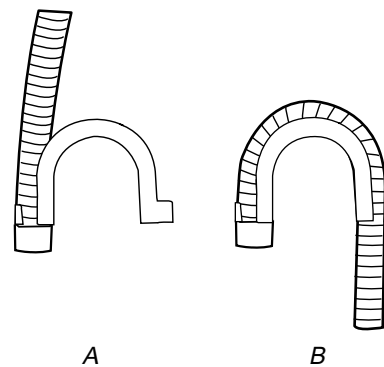

A. Snap either end of the drain hose form to the drain hose at the point where the corrugation begins.

B. Bend drain hose over drain hose form and snap into place.



### To keep drain water from going back into the washer:

- Do not straighten the drain hose, and do not force excess drain hose into standpipe. Hose should be secure, but loose enough to provide a gap for air.
- Do not lay excess hose on the bottom of the laundry tub.

### Floor drain

You may need additional parts. See Floor Drain under “Tools and Parts.”

### SECURE THE DRAIN HOSE

1. Drape the power cord over the washer top.
2. Move the washer to its final location.
3. Place the drain hose in the laundry tub or standpipe. See illustrations A and B.

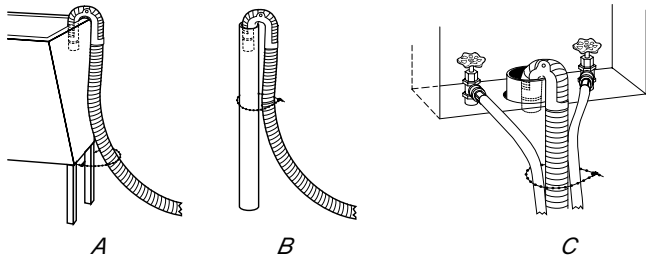

4. If the washer faucets and the drain standpipe are recessed, put the hooked end of the drain hose in the standpipe. See illustration C.

### NOTES:

- Do not force excess drain hose back into the rear of the washer.
- To prevent siphoning, do not seal the drain hose into the standpipe.

### LEVEL THE WASHER

One foot has been installed at a different height on your new washer. The other three feet were preset at the factory. Properly leveling your washer will minimize excessive noise and vibration.

1. Push on the upper front panel to be sure that the washer is on the rear feet. Lower the right front foot until it contacts the floor. Check the levelness of the washer by placing a level on the top edge of the washer, first side to side, then front to back.

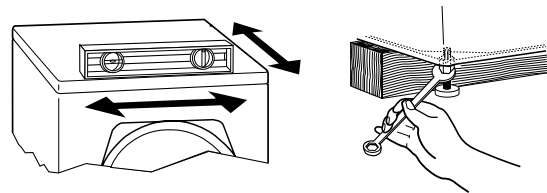

If the washer is against a wall, move the washer out slightly before tipping back. First prop the front with a wood block and adjust the feet as necessary; then prop the back and adjust feet as necessary. Repeat this step until washer is level.

2. Make sure that all four feet are stable and resting on the floor. Then check that the appliance is perfectly level (use a level).
3. After the washer is level, use a 17 mm open-end wrench to turn the nuts on the feet tightly against the washer cabinet.

**IMPORTANT:** All four feet must be tightened. If the nuts are not tight against the washer cabinet, the washer may vibrate.

4. When you are pushing on the edges of the washing machine top plate, the machine should not move front to back, side to side, or diagonally.
5. Slide the washer to its final location.
6. Confirm the levelness of the washer.

## COMPLETE INSTALLATION

1. Check the electrical requirements. Be sure that you have the correct electrical supply and the recommended grounding method. See “Electrical Requirements.”
2. Check to be sure all parts are now installed. If there is an extra part, go back through the steps to see which step was skipped.
3. Check that you have all of your tools.
4. Dispose of or recycle all packaging materials.
5. Check that the water faucets are on.
6. Check for leaks around faucets and inlet hoses.

## **WARNING**



### **Electrical Shock Hazard**

**Plug into a grounded 3 prong outlet.**

**Do not remove ground prong.**

**Do not use an adapter.**

**Do not use an extension cord.**

**Failure to follow these instructions can result in death, fire, or electrical shock.**

7. Plug into a grounded 3 prong outlet.
8. Read “Washer Use.”
9. To test and to clean your washer, use 1/2 the manufacturer’s recommended amount for a medium sized load. Pour the detergent into the detergent dispenser. Select NORMAL/CASUAL, and then select START. Allow the washer to complete one whole cycle.



*Use only HE High Efficiency detergent.*

— NOTES —

# PRODUCT OPERATION

## FEATURES AND BENEFITS

The front-loading high efficiency washer was designed to conserve resources and lower your water and energy bills. The washer is designed to determine and then provide the amount of water needed for the best performance. The time of operation may be greater for this new system than for a conventional washer.

### **ELECTRONIC CONTROLS**

Flexible electronic controls are easy to use whether you are a beginner or an expert.

### **AUTO WATER LEVEL**

Adjusting to the size of the load, this feature allows the washer to use the minimal amount of water needed to clean and rinse the clothes. With a low water level, you can obtain the same results with smaller amounts of additives. Because only the required amount of water is used, the washer saves energy, too. You can obtain the same washing results for small and large loads size.

### **LARGER LOAD SIZE**

Since there is no agitator, you can wash larger, bulkier items such as an average size sleeping bag. You are also able to wash more clothes at one time, which means fewer loads. You can wash a pillow or a large stuffed teddy bear.

### **SUSPENSION SYSTEM**

To reduce washer “walk” and “off-balance” conditions, your new washer combines:

- 2 Springs to isolate vibration
- 3 or 4 shock absorbers at the washer base to minimize movement

### **STAINLESS STEEL DRUM**

The stainless steel drum eliminates corrosion and enables higher spin speeds for more water extraction, reducing drying time.

### **ADAPTIVE VARIABLE SPEED MOTOR**

The motor adapts to the load size and to the cycle selected to give the optimum cleaning, rinsing, and spinning conditions. The motor can handle slow speeds needed for delicate items and is powerful enough to drive an average clothes load up to a high-speed spin.

### **SPIN SPEEDS**

This washer automatically selects the spin speed based on the cycle selected. For some cycles, the default spin speed can be changed if desired. This washer offers up to three different spin speed choices.

### **ADD A GARMENT**

This option is available in all wash cycles except Rinse/Spin and Drain/Spin. When this option is available at the beginning of the cycle the Add A Garment status light will illuminate for the first 7 minutes. This washer allows a 7-minute period in which forgotten garments may be added to a load.

### **DYNAMIC BALANCE**

A precision balancing system allows the washer to reach high-speed spins. The washer spins faster so that clothes coming out of the washer will have less moisture than with traditional top load machines. In addition, if the Dynamic Balance system detects off-balance loads during spinning, it redistributes the clothes so that they are evenly balanced.

## **SMART DISPENSERS**

The three compartments in the dispenser allow loading of all laundry additives before the washer is started. The additives will be dispensed into the wash at the optimal time for high performance cleaning. The bleach release system is included in the detergent advantage system. The detergent is added at the beginning of the cycle, and the bleach is

added after the enzymes have had a chance to do their cleaning. The fabric softener is dispensed in the rinse cycle or in the EXTRA RINSE, if selected. The Detergent Advantage System Dispenser tray is easily removed for cleaning.



*Use only HE High Efficiency detergent.*

# WASHER USE

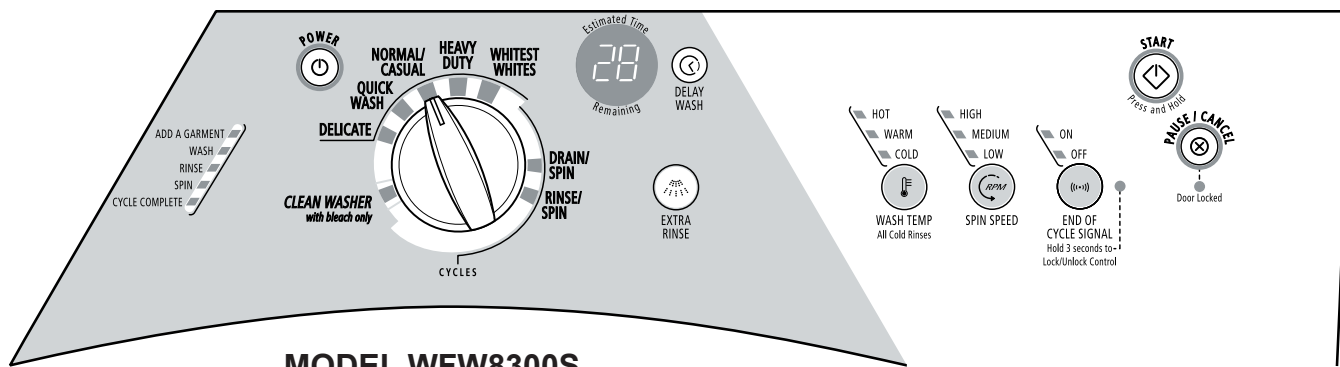

MODEL WFW8300S

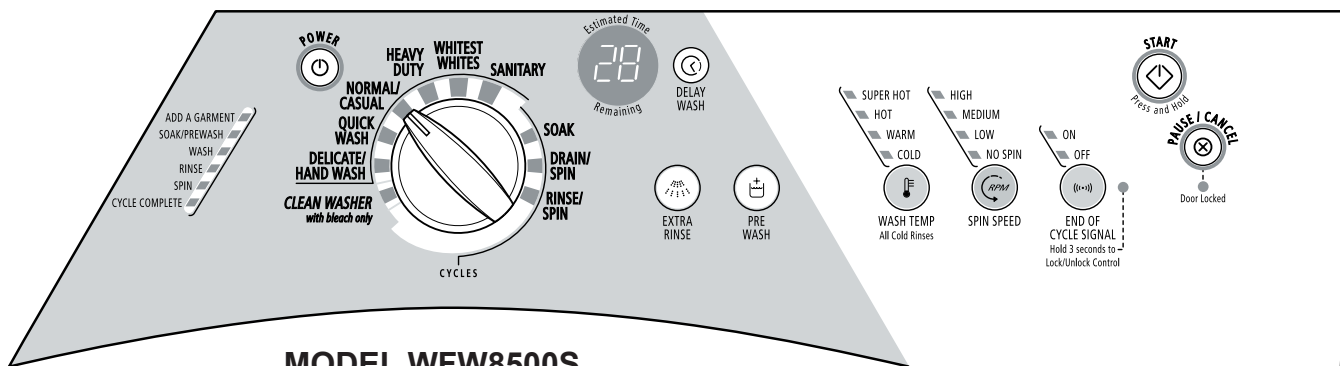

MODEL WFW8500S

## STARTING THE WASHER

### ⚠ WARNING



#### Fire Hazard

Never place items in the washer that are dampened with gasoline or other flammable fluids.

No washer can completely remove oil.

Do not dry anything that has ever had any type of oil on it (including cooking oils).

Doing so can result in death, explosion, or fire.

**WARNING:** To reduce the risk of fire, electric shock, or injury to persons, read the IMPORTANT SAFETY INSTRUCTIONS before operating this appliance.

The following is a guide to using the washer. Please refer to specific sections of this manual for more detailed information.

Do not store laundry products on the top surface of this washer. Vibration is normal during operation.

## USING THE PROPER DETERGENT

Use only High Efficiency detergents. The package for this type of detergent will be marked “HE” or “High Efficiency.” This wash system, along with less water, will create too much sudsing with a regular non-HE detergent. Using regular detergent will likely result in washer errors, longer cycle times, and reduced rinsing performance. It may also result in component failures and noticeable mold or mildew. HE detergents are made to produce the right amount of suds for the best performance. Follow the manufacturer’s instructions to determine the amount of detergent to use.



*Use only HE High Efficiency detergent.*

### First Wash Cycle Without Laundry

Before washing clothes for the first time, if not completed during the final installation step, choose the Normal/Casual cycle and run it without clothes. Use only HE High Efficiency detergent. Use 1/2 the manufacturer’s recommended amount for a medium-sized load. This initial cycle serves to ensure the interior is clean before washing clothes.

### For All Wash Cycles

#### 1. To load washer

Open the washer door by pulling on the handle. Sort laundry according to color and type of fabric. Place a load of sorted clothes in the washer. Do not overload washer. Overloading can cause poor cleaning.

- The washer can be fully loaded, but not tightly packed. Washer door should close easily.
- Mix large and small items. Avoid washing a single item. Load evenly.
- Wash small items such as infant socks in mesh garment bags. It is recommended that more than one garment bag be used and that each garment bag be filled with equal amounts of material.

- When unloading garments, occasionally check under the rubber rim at the front of the tub for small items.
2. Close the washer door by pushing it firmly until the lock clicks. The washer door will remain locked during the wash cycle.

**NOTE:** After any wash cycle is completed, the door must be opened and then closed before a new cycle can begin. The door can be opened only if PAUSE/CANCEL is selected while the ADD A GARMENT light is illuminated or if the cycle has been canceled. See “To cancel a cycle” in the “Changing Cycles and Options Section.”

3. Open the dispenser drawer and add laundry additives to the detergent, bleach, or fabric softener compartments. Close drawer slowly to avoid spills. See “Using the Dispenser.”
4. Turn on the washer by selecting POWER. Select one of the cycles by turning the cycle selector. The indicator light for the selected cycle will illuminate. When selecting a Wash Cycle, the preset Modifiers and Options, Water Temp, and Spin Speed for the selected cycle will illuminate. The preset settings provide the recommended fabric care for the selected cycle. See “Wash Cycles.”
5. Select the desired OPTIONS. Not all Options are available with all cycles. See “Options.”
6. If desired, select the END OF CYCLE SIGNAL. The signal is helpful when you are washing items that should be removed from the washer as soon as it stops. Press END OF CYCLE SIGNAL to select ON or OFF.
7. **To begin the wash cycle immediately**  
Select and hold START (for approximately 1 second).
  - If you do not select START within 5 minutes of choosing a cycle, the washer automatically shuts off.

- When the wash cycle is complete, the CYCLE COMPLETE status light illuminates, the door unlocks, and the wash load can be removed from the washer. The washer powers down automatically 5 minutes after the cycle is complete and the CYCLE COMPLETE light goes off. To power down the washer manually after the wash cycle is complete, select PAUSE/CANCEL once.

### 8. To begin the wash cycle later

Select DELAY WASH until the desired delay time (in hours) is displayed. Select START. The countdown to the wash cycle will show in the display window.

**IMPORTANT:** When delaying a cycle, use only powdered detergents in the main wash compartment since liquid detergents may seep out of the compartment during Delay, before the wash cycle begins.

## USING THE DISPENSER

The washer has a dispenser drawer with three separate compartments for your laundry additives—one is for detergent, one is for liquid chlorine bleach, and one is for liquid fabric softener. Laundry additives are diluted and dispensed automatically at the proper time during the wash cycle, making it unnecessary for you to return to the washer during the cycle to add them.

It is normal for small amounts of water to remain in the dispensers when the wash cycle is complete.

Do not put laundry additives directly into the wash tub. Always use the proper dispensers when adding laundry additives.

### Choosing the Right Detergent

Use only High Efficiency detergents. The package for this type of detergent will be marked “HE” or “High Efficiency.” This wash system, along with less water, will create too much sudsing with a regular non-HE detergent. Using regular detergent will likely result in washer errors, longer cycle times, and reduced rinsing

performance. It may also result in component failures and noticeable mold or mildew. HE detergents are made to produce the right amount of suds for the best performance. Follow the manufacturer’s instructions to determine the amount of detergent to use.



Use only HE High Efficiency detergent.

### To fill dispenser compartments

1. Pull out the dispenser drawer.
2. Add the desired laundry additives to the proper compartment.
3. Push in the dispenser drawer slowly and completely (to avoid a spill).

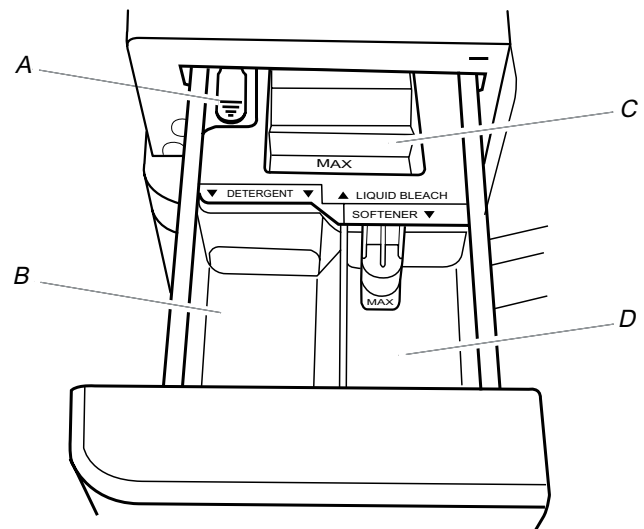

Dispenser

- A. Dispenser release lever
- B. Main Wash detergent compartment
- C. Liquid chlorine bleach compartment
- D. Fabric softener compartment

### Main Wash detergent compartment (Letter B in Dispenser Illustration)

Add liquid or powdered HE detergent to this compartment for your main wash cycle.

- Powdered color-safe bleach may be added to the Main Wash compartment along with the powdered detergent.



- Liquid detergent: Measure the amount of liquid detergent with the measurement device which comes with the detergent. Add no more than the manufacturer's recommended amount. The liquid detergent flows immediately into the washer.
- Powdered detergent: Measure the amount of powdered detergent with the measurement device which comes with the detergent. Add no more than the manufacturer's recommended amount.

**NOTE:** Overfilling could cause an oversudsing condition.

### Chlorine bleach compartment (Letter C in Dispenser Illustration)

Add NO MORE THAN 2/3 cup (160 mL) liquid chlorine bleach to this compartment. The bleach will be automatically diluted and dispensed at the best time during the first rinse after the wash cycle. This compartment cannot dilute powdered bleach.

- Use only liquid chlorine bleach in this dispenser. Do not use this dispenser to add powdered chlorine or any form of colorsafe bleach to your load.
- Always measure liquid chlorine bleach. Use a measuring cup with a pour spout; do not guess. Follow the manufacturer's directions for proper use.
- Do not fill beyond the "MAX" level.

**NOTE:** Overfilling could cause garment damage.

### Fabric softener compartment (Letter D in Dispenser Illustration)

Add 1/4 cup (60 mL) liquid fabric softener to this compartment. Fabric softener will be automatically dispensed in the final rinse or in the EXTRA RINSE, if selected.

- Do not fill beyond the "MAX" level.

## PAUSING OR RESTARTING

1. To pause the washer at any time, select PAUSE/CANCEL.
2. To continue the cycle, select and hold START (for approximately 1 second).

## CHANGING CYCLES AND OPTIONS

Not all Options are available with all Cycles.

Cycles and Options can be changed anytime before START is selected.

### To stop a cycle and select a new cycle

1. Select PAUSE/CANCEL once.
2. Select desired cycle.
3. Select the desired OPTIONS.
4. Select and hold START (for approximately 1 second) to restart the washer at the beginning of the new cycle.

### To cancel a cycle

1. Select PAUSE/CANCEL twice.
2. The washer powers down, the door unlocks, and clothes can be removed.

**NOTE:** If the water level or the temperature is too high, the washer will drain automatically before the door unlocks.

### To change Options after the cycle has started

1. Select PAUSE/CANCEL once.
2. Select the desired OPTIONS. If the option is not available, the machine will beep.
3. Select and hold START (for approximately 1 second) to continue the cycle.

### To drain the washer manually

1. Select PAUSE/CANCEL.
2. Select DRAIN/SPIN.
3. Select and hold START (for approximately 1 second) to begin the drain.
4. When the spin is complete, the door unlocks. Items can be removed from the washer.

## STATUS LIGHTS

These lights show which portion of the cycle the washer is operating. They also indicate when you can add an additional item to the wash cycle and when the controls are locked.

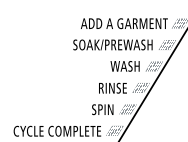

## Adding items

You can add items to the washer after the wash cycle has started, if the ADD A GARMENT status light is illuminated. All cycles have this feature except Rinse/Spin and Drain/Spin.

### To add items

1. Select PAUSE/CANCEL. The washer door unlocks, and items can be added.
2. To continue the cycle, close the door and select and hold START (for approximately 1 second).
3. To unlock the door after the Add a Garment period, press PAUSE/CANCEL twice. This will cancel the Wash Cycle.

## Cycle Complete

The Cycle Complete light stays on for 5 minutes after the cycle is complete. The washer will then power down.

## Locking controls

The Control Lock avoids unintended use of the washer. You can also use the control lock feature to avoid unintended cycle or option changes during a cycle. When CONTROL LOCKED is lit, all buttons are disabled except for PAUSE/CANCEL and START. You can lock the controls while the washer is operating.

### To lock the controls

Select and hold END OF CYCLE SIGNAL for 3 seconds. The CONTROL LOCKED status light illuminates.

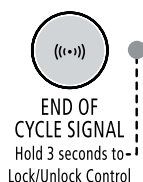

### To unlock the controls

Select and hold END OF CYCLE SIGNAL for 3 seconds until the CONTROL LOCKED Status light turns off.

## Estimated Time Remaining

The cycle times vary automatically based on your water pressure, water temperature, detergent, and clothes load. The cycle time will be extended if oversudsing occurs or the load is unbalanced. The SUDs routine removes extra suds and assures proper rinsing of your garments. The options you select will also affect the cycle times that are shown in the Preset Cycle Settings table. The Estimated Time Remaining can change up to 30 minutes under extreme conditions.

## Door Locked

When the status light illuminates, the door is locked. The door is locked and unlocked automatically, depending on the stage of the wash cycle.

## CYCLES

### Wash Cycles

Choose Wash Cycles by rotating the Cycle selector knob to the desired cycle. The indicator light for the cycle selected will illuminate. Each cycle is designed for different types of fabric and soil levels.

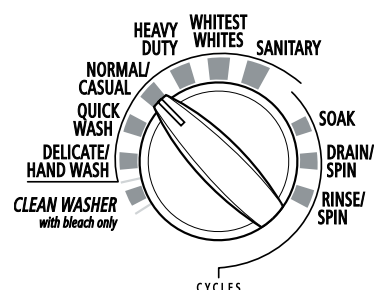

- Each cycle has a preset cycle time, WASH TEMP, SPIN SPEED, and may have preset Options. The preset settings provide the recommended fabric care for the selected cycle.
- The preset settings can be changed anytime before START is selected. Not all Options and Modifiers (WASH TEMP, SPIN SPEED) are available with all Cycles. To change settings after the cycle has started, select PAUSE/CANCEL, then select the desired settings. Select and hold START (for approximately 1 second) to continue the cycle.

## Preset Cycle Settings

Each cycle has a preset Cycle Time, WASH/RINSE TEMP, and SPIN SPEED. The preset settings provide the recommended fabric care for the selected cycle. See chart.

Cycle	Estimated Time* (hr:min)	Wash Temp	Spin Speed
Sanitary	3:00	Super Hot 153°F (67°C)	High
Whitest Whites	2:00	Hot 140°F (60°C)	High
Heavy Duty	2:00	Hot 140°F (60°C)	High
Normal/Casual	0:56	Warm 95°F (35°C)	High
Quick Wash (2-3 items)	0:25	Warm 95°F (35°C)	High
Delicate/ Hand Wash	0:39	Warm 95°F (35°C)	Low
Clean Washer	0:56	N/A	Low
Rinse/Spin	0:26	Cold 68°F (20°C)	High
Drain/Spin	0:14	N/A	High
Soak	0:29	Cold 68°F (20°C)	No Spin

\* The cycle times vary automatically based on your water pressure, water temperature, detergent, and clothes load. The cycle time will be extended if oversudsing occurs or the load is unbalanced.

### Sanitary

Use this cycle to clean heavily soiled, colorfast fabrics. This cycle combines a super hot water temperature and fast speed tumbling to help ensure the removal of heavy soils and stains. It is recommended that you set your hot water heater to 120°F (49°C) to ensure proper performance during this cycle. The Sanitary cycle also helps eliminate 99.999% of 3 common infectious bacteria, even when no bleach is used. High-speed spin helps shorten drying time.

### Whitest Whites

This cycle is especially designed for cleaning loads of soiled white fabrics with the addition of bleach. Hot washing temperatures assure optimal bleach activity. An additional rinse provides optimal rinse performance to avoid chlorine residues on your laundry. This cycle combines fast-speed tumbling, longer wash time, and high-speed spin to shorten drying time. It also includes Extra Rinse as a preset setting.

### Heavy Duty

Use this cycle to wash loads of sturdy, colorfast fabrics and Heavy soiled garments. This cycle combines fast-speed tumbling, longer wash time, and high-speed spin to shorten drying times.

### Normal/Casual

Use this cycle to wash loads of no-iron fabrics such as sport shirts, blouses, casual business clothes, permanent press blends, cottons and linens, and synthetic fabrics. This cycle combines medium-speed tumbling, high-speed spin, and a load cooling process to reduce wrinkling.

### Quick Wash

Use this cycle to wash small loads of 2-3 lightly soiled garments that are needed in a hurry. This cycle combines fast-speed tumbling, a shortened wash time, and high-speed spin to shorten drying time. Large wash loads will result in the machine increasing the wash time.

### Delicate/Hand Wash

Use this cycle to wash sheer fabrics, lingerie, hand washable, and special-care garments. This cycle combines low-speed tumbling and low-speed spin for gentle fabric care.

- Use mesh garment bags to wash undergarments such as underwire bras, items with strings, and small items such as socks.

## Clean Washer

Use the Clean Washer cycle once a month to keep the inside of your washer fresh and clean. This cycle uses a higher water level in combination with liquid chlorine bleach to thoroughly clean the inside of your washing machine. See “Cleaning The Washer.”

**IMPORTANT:** Do not place garments or other items in the washer during the Clean Washer cycle. Use this cycle with an empty wash tub.

## Rinse/Spin

Use this cycle to get a rinse and spin only. This cycle combines fast-speed tumbling and high-speed spin. If desired, you can reduce the spin speed by selecting the speed you want from the SPIN SPEED modifier.

### Rinse & Spin is useful for:

- Loads that need rinsing only.
- Adding fabric softener to a load using the fabric softener dispenser.

## Drain/Spin

Use this cycle to drain your washer or to drain and spin your wash load. The spin speed is preset to HIGH. If desired, you can reduce the spin speed by selecting the speed you want from the SPIN SPEED modifier.

**NOTE:** Loads of synthetics, delicate fabrics, handwashables, and woolens should be drained with no spin or low spin to avoid fabric stress.

## Soak

Use the Soak cycle to help remove small spots of set-in stains on fabrics. This cycle provides a soak time with warm or cold water, followed by drain. Extra water, a short tumbling phase for equal distribution of the laundry, and a soaking time without drum movement, to help improve the removal of set-in stains. Drain without spin assures gentle treatment, even for delicate items.

## NORMAL SOUNDS

As with any new product, you will hear sounds that you are not accustomed to. You may hear various sounds when the door is locked or unlocked, and during the washing, rinsing, or spinning process. Between changes in wash actions, there will be momentary pauses. You will hear water spraying and splashing during the wash and rinse cycles. These new sounds and pauses are part of normal washer operation. See “Troubleshooting.”

## OPTIONS AND MODIFIERS

You can customize your wash by adding options to your cycle selections. You can add or change an option after starting a cycle anytime before the selected option begins. Not all options are available with all cycles.

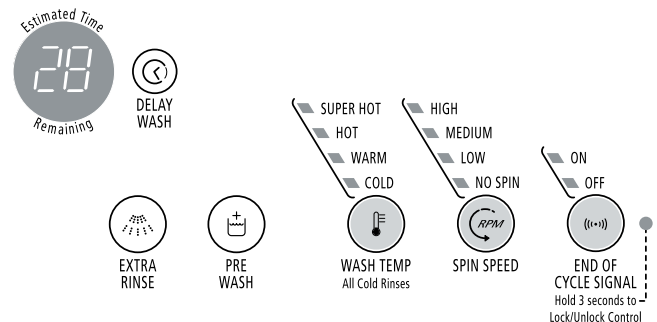

- See the “Laundry Guide” section for an overview of possible options for each Wash Cycle selection.
- If an option is available with a selected cycle, the light for that option will illuminate when selected.
- If an option is unavailable with a selected cycle, there will be a short tone and the light for that option will not illuminate when selected.

## Delay Wash

Use this to begin the wash cycle later.

- Select DELAY WASH until the desired time (in hours) shows in the Estimated Time Remaining display.
- Select START. The countdown to the wash cycle will show in the display window.

## Extra Rinse

An extra rinse can be used to aid in the removal of detergent or bleach residue from garments. This option provides an additional rinse with the same water temperature as in the normal rinse. It is a preset setting for the Whitest Whites cycle. You may select or deselect by pressing EXTRA RINSE.

## Prewash

Use this option for loads of heavily soiled garments that need pretreatment.

- Add detergent to the Main Wash Compartment of the dispenser drawer.
- Use powdered detergent to keep laundry additives from predispensing into the wash system.

This option adds tumbling time prior to the selected main cycle. The washer continues automatically from prewash into the main wash cycle.

## Wash Temp

Each cycle has a preset water temperature setting. To change the water temperature, select the WASH TEMP button until the desired setting is illuminated.

Select a water temperature based on the type of load you are washing. Use the warmest wash water safe for fabrics. Follow garment label instructions.

The water temperature for all rinse cycles is cold. Cold rinses save energy.

## Temperature Guide

Wash Water Temperature	Suggested Fabrics
<b>SUPER HOT</b>	Sturdy colorfast fabrics Heavy soils
<b>HOT</b>	Whites and pastels Heavy soils
<b>WARM</b>	Bright colors Moderate to light soils
<b>COLD</b>	Colors that bleed or fade Light soils

In wash water temperatures colder than 60°F (15.6°C), detergents do not dissolve well. Soils may be difficult to remove.

## Auto Temp Control

ATC (Auto Temp Control) electronically senses and maintains a uniform water temperature. ATC regulates incoming hot and cold water. The ATC is automatically turned ON when a cycle is selected. See Preset Cycle Settings table in “Cycles.”

- ATC works for the wash temperature with Warm and Cold settings.
- The Cold rinse temperatures depend on the cold water at the faucet.

## Spin Speed

Each cycle has a preset SPIN SPEED. To change the spin speed, select the SPIN SPEED button until the desired setting is illuminated.

## End of Cycle Signal

This signal is helpful when you are removing items from the washer as soon as it stops. Select ON or OFF.

## LAUNDRY GUIDE

Refer to the chart below for suggested load types and their corresponding cycles. Listed to the right are the options available to each of these washer cycles.

CYCLE	SUGGESTED LOAD TYPE	AVAILABLE OPTIONS			
		Delay Wash	Extra Rinse	Pre Wash	End of Cycle Signal
<b>Sanitary</b>	Heavily soiled underwear, towels, work cloths, diapers, etc.	✓	✓	✓	✓
<b>Whitest Whites</b>	Soiled white fabrics	✓	✓	✓	✓
<b>Heavy Duty</b>	Heavily soiled underwear, towels, shirts, etc., made of cotton	✓	✓	✓	✓
<b>Normal/Casual</b>	Normally soiled blouses, shirts, overalls, etc., made of polyester, nylon, cotton, linen, or cotton blends	✓	✓	✓	✓
<b>Quick Wash</b>	Small loads of 2-3 lightly soiled cotton, polyester, nylon, and cotton blends	✓	✓	✓	✓
<b>Delicate/ Hand Wash</b>	Curtains and delicate clothing, dresses, skirts, shirts and blouses, fabrics made of silk, and special care items marked "Hand Washable"	✓	✓	✓	✓
<b>Clean Washer</b>	No clothes	✓	✓	✓	✓
<b>Rinse &amp; Spin</b>	All loads	✓	✓	✓	✓
<b>Drain &amp; Spin</b>	All loads	✓		✓	✓
<b>Soak</b>	All loads	✓			



# WASHER CARE

## CLEANING THE WASHER

### Cleaning the Door Seal/Bellow

1. Open the washer door and remove any clothing or items from the washer.
2. Inspect the gray colored seal/bellow between the door opening and the basket for stained areas. Pull back the seal/bellow to inspect all areas under the seal/bellow and to check for foreign objects.

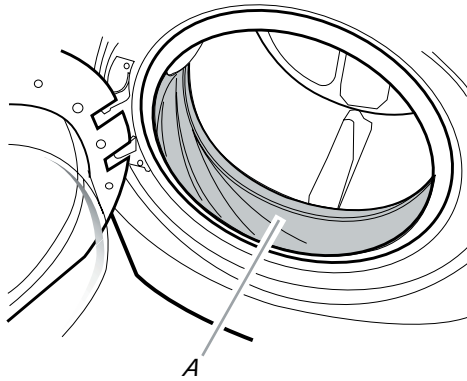

A. Seal/Bellow

3. If stained areas are found, wipe down these areas of the seal/bellow, using the procedure that follows.
  - a) Mix a dilute solution, using 3/4 cup (177 mL) of liquid chlorine bleach, and 1 gal. (3.8 L) of warm tap water.
  - b) Wipe the seal/bellow area with the dilute solution, using a damp cloth.
  - c) Let stand 5 minutes.
  - d) Wipe down area thoroughly with a dry cloth and let the washer interior air dry with door open.

### IMPORTANT:

- Wear rubber gloves when cleaning for prolonged periods.
- Refer to the bleach manufacturer's instructions for proper use.

### Washer Maintenance Procedure

This washer has a special cycle that uses higher water volumes in combination with liquid chlorine bleach to thoroughly clean the inside of the washer.

### NOTES:

- Read these instructions completely before beginning the cleaning process.
- If necessary, the cleaning cycle may be interrupted by pressing the PAUSE/CANCEL button. This will stop the cycle. A RINSE/SPIN cycle must then be run to thoroughly rinse the remaining bleach from the unit. Failure to do so will cause damage to the unit and clothing added to the next cycle.

### Begin procedure

1. Open the washer door and remove any clothing or items from the washer.
2. Be sure the door is closed.
3. Open the dispenser drawer and immediately add 2/3 cup (160 mL) of liquid chlorine bleach to the bleach compartment.

**NOTE:** Do not add any detergent to this cycle. Use of more than 2/3 cup (160 mL) of bleach will cause product damage over time.

4. Be sure the dispenser drawer is closed.
5. Select the CLEAN WASHER cycle.
6. Press START.

**NOTE:** The basket will rotate, then the door will unlock, lock again, and then the cycle will continue.

- The machine will not fill, but the basket will rotate while the washer runs a short sensing cycle. This will take approximately 3 minutes.
7. The cycle will determine if clothing or other items are in the washer.

- a) If no items are detected in the washer, it will proceed to Step 8.
- b) If any items are detected in the washer, all the Cycle lights will flash and the WASH and CONTROLS LOCKED lights will remain lit. The door will unlock.

Press PAUSE/CANCEL to cancel the failure code. Then repeat steps 1, 2 and 6 to start the cycle again.

8. Once the cycle has begun, allow the cycle to complete.
9. After the cycle is complete, leave the door open, slightly, to allow for better ventilation and drying of washer interior.

### **Always do the following to maintain washer freshness**

- Use only HE High Efficiency detergent.
- Leave the door slightly open after each cycle to allow for better ventilation and drying of washer interior.
- Repeat the cleaning procedure monthly, using 2/3 cup (160 mL) of liquid chlorine bleach.
- If the procedure does not sufficiently improve the machine freshness, please evaluate your installation and usage conditions for other causes.

### **Cleaning the exterior**

Use a soft damp cloth or sponge to wipe up any spills. Occasionally wipe the outside of your washer to keep it looking new. Use mild soap and water. Do not use abrasive products.

### **Cleaning the dispenser drawer**

The dispenser drawer is removable for easy cleaning.

1. Unlock the dispenser drawer by pressing the Release Lever. See “Using the Dispenser.” Remove the drawer.
2. Remove the inserts (the siphon from the softener and bleach compartments).
3. Wash the parts under running water.  
**NOTE:** Do not wash components in the dishwasher.
4. Replace the inserts and return the dispenser to the drawer.

## **WATER INLET HOSES**

Replace inlet hoses after five years of use to reduce the risk of hose failure. Periodically inspect and replace inlet hoses if bulges, kinks, cuts, wear or leaks are found.

When replacing your inlet hoses, record the date of replacement.

## **VACATION, STORAGE, & MOVING CARE**

Install and store your washer where it will not freeze. Because some water may stay in the hoses, freezing can damage your washer. If storing or moving your washer during freezing weather, winterize it.

### **Non-use or vacation care:**

Operate your washer only when you are at home. If you will be on vacation or not using your washer for an extended period of time, you should:

- Unplug washer or disconnect power.
- Turn off the water supply to the washer. This helps avoid accidental flooding (due to a water pressure surge) while you are away.
- Slightly open door to provide ventilation.

### **To winterize washer:**

1. Put 1 qt (1 L) of R.V.-type antifreeze in the drum.
2. Run washer on a Drain/Spin cycle.
3. Unplug washer or disconnect power.
4. Shut off both water faucets.
5. Disconnect water inlet hoses from faucets and drain.

### **To use washer again:**

1. Flush water pipes.
2. Reconnect water inlet hoses to faucets.
3. Turn on both water faucets.



## **⚠ WARNING**



### **Electrical Shock Hazard**

**Plug into a grounded 3 prong outlet.**

**Do not remove ground prong.**

**Do not use an adapter.**

**Do not use an extension cord.**

**Failure to follow these instructions can result in death, fire, or electrical shock.**

4. Plug in washer or reconnect power.
5. Run the washer through the Normal/Casual cycle. Use only HE High Efficiency detergent. Use 1/2 the manufacturer's recommended amount for a medium sized load.

### **To transport the washer:**

1. If washer will be moved during freezing weather, put in 1 qt (1 L) of R.V.-type antifreeze in the drum. Run washer on a Drain/Spin cycle.
2. Unplug the power cord.
3. Disconnect the drain hose from the drain system and attach to rear panel clips.
4. Shut off both water faucets.
5. Disconnect the water inlet hoses from faucets, then drain the hoses and clip them to the rear panel of the washer.
6. **IMPORTANT:** Call service. Do not reuse transport bolts. Unit must be transported in the upright position. To avoid suspension and structural damage, your machine must be properly set up for relocation by a certified technician.

### **Reinstalling the washer**

1. Follow the "Installation Instructions" to locate, level and connect the washer.
2. Run the washer through the Normal/Casual cycle to clean the washer and remove the antifreeze, if used. Use only HE High Efficiency detergent. Use 1/2 the manufacturer's recommended amount for a medium sized load.

# TROUBLESHOOTING

## WASHER & COMPONENTS

### ERROR CODES

When all cycle indicator lights are blinking, see which status light is also illuminated and then check the list below for potential problem and troubleshooting checks. An error code may be shown in the Estimated Time Remaining display (on some models).

- **“Spin” and “Wash” (HT “Rinse” and “Cycle Complete”) illuminated or “F20” on display (Water Inlet Problem—no water or insufficient water supply)**

Select PAUSE/CANCEL twice to cancel the cycle. Unplug washer or disconnect power.

#### Check the following:

Are water faucets completely turned on?

Are screens at inlet hose connection to washer clogged? Are water inlet hoses kinked?

Are water inlet hoses frozen?

### ⚠ WARNING



#### Electrical Shock Hazard

**Plug into a grounded 3 prong outlet.**

**Do not remove ground prong.**

**Do not use an adapter.**

**Do not use an extension cord.**

**Failure to follow these instructions can result in death, fire, or electrical shock.**

Plug in washer or reconnect power. Re-select cycle and press START.

- **“Spin,” “Wash” (HT “Rinse,” “Cycle Complete”) and “Add a Garment” illuminated or “F21” on display (Drain Problem)**

Select PAUSE/CANCEL twice to cancel the cycle. Unplug washer or disconnect power.

#### Check the following:

Is the drain hose kinked, frozen, clogged, or more than 96" (2.4 m) above the floor?

- **Any other Status light combination (Electrical Problem)**

Select PAUSE/CANCEL twice to cancel the cycle. Select DRAIN/SPIN if there is excessive water in the washer.

Re-select cycle and press START.

### NOISY, VIBRATING, OFF-BALANCE

- **Is the washer level?**

The washer must be level. The four feet should be properly installed, and the nuts should be tightened against the washer cabinet.

All four feet of the washer must be in firm contact with the floor. If the washer is on a pedestal, the washer must be secured to the pedestal and all four pedestal feet must be in firm contact with the floor.

- **Washer making a different noise?**

As with any new product, you will hear sounds that you are not accustomed to. You may hear various sounds when the door is locked or unlocked, and during the washing, rinsing, or spinning process. Between changes in wash actions, there will be momentary pauses. You will hear water spraying and splashing during the wash and rinse cycles. These new sounds and pauses are part of normal washer operation.

- **Is washer installed on a sturdy and solid floor?**

Refer to the “Installation Instructions” for flooring requirements. Noise and vibration may be reduced by placing a piece of 3/4" (19.1 mm) plywood underneath your washer.

The plywood may extend underneath both washer and dryer to keep them at equal heights.

- **Is the washer gurgling or humming?**

As water is drained from the washer, you may hear air being pulled through the pump. This happens during the end of draining. It is normal.

- **Are you washing items with metal snaps, buckles or zippers?**

You may hear metal items touching the washer drum. This is normal.

- **Were the 4 shipping bolts in the back of the machine removed?**

See “Remove Transport System.”

---

## LEAKING

---

- **Was the door opened during “Add a garment”?**  
Water can drip off the inside of the door, when the door is opened after the start of a cycle.
- **Is HE detergent being used?**  
The non-High Efficiency detergents can cause oversudsing that can leak from the rear of the washer.
- **Are the fill hoses tight?**
- **Are the fill hose gaskets properly seated?**  
Check both ends of each hose. See “Connect the Inlet Hoses.”
- **Is the drain hose properly installed?**  
The drain hose should be secured to the drainpipe or laundry tub. See “Secure the Drain Hose.”
- **Is the sink or drain clogged?**  
Sink and drainpipe must be able to carry away 17 gal. (64 L) of water per minute. If clogged or slow, water can back up out of drainpipe or sink. Check household plumbing (laundry tubs, faucets, drainpipe, water pipes) for leaks.

---

## DISPENSER OPERATION

---

- **Did you follow the manufacturer’s directions when adding detergent and fabric softener to the dispensers?**  
Measure detergent and fabric softener. Slowly pour into the dispensers. Wipe up all spills. Dilute fabric softener in the fabric softener dispenser.
- **Did you put powdered or liquid color-safe bleach into the liquid chlorine bleach dispenser (on some models)?**  
Add powdered or liquid color-safe bleach directly to the washer basket. Do not use the chlorine bleach dispenser for color-safe bleach.

- **Is the fabric softener dispenser clogged?**  
Clean the fabric softener dispenser. See “Washer Care” for details.
- **Are the laundry additives in the correct dispenser compartment?**  
Add the correct amounts of detergent, fabric softener or liquid chlorine bleach to the correct compartments. Add powdered or liquid color-safe bleach to the Main Wash compartment.
- **Is there water in the dispenser at the end of the cycle?**  
A small amount of water will remain in the dispenser compartment. This is normal.

---

## WASHER ODOR

---

- **Have you run the Clean Washer Cycle lately?**  
To freshen your washer and to avoid odors, see “Cleaning The Washer.”
- **Are you using HE detergent?**  
Use of non-HE detergent can cause a film residue which can result in odor.
- **Did you leave the door open after use?**  
This washer has a tight seal to avoid water leaks. To avoid odors leave the door open to allow the washer to dry between uses.

---

## DOOR WON’T UNLOCK

---

- **Did all of the water drain out of the washer during the spin?**  
Select DRAIN/SPIN to remove any water remaining in the washer. The washer door will unlock at the end of the drain.
- **Is the door locked and is the “Add a garment” light on?**  
Press PAUSE/CANCEL once. The door will unlock.

## WASHER OPERATION

---

### WASHER WON'T RUN, FILL, RINSE, OR TUMBLE; WASHER STOPS

---

#### **! WARNING**



#### **Electrical Shock Hazard**

**Plug into a grounded 3 prong outlet.**

**Do not remove ground prong.**

**Do not use an adapter.**

**Do not use an extension cord.**

**Failure to follow these instructions can result in death, fire, or electrical shock.**

- **Is the power cord plugged into a grounded 3 prong outlet?**  
Plug power cord into a grounded 3 prong outlet.
- **Are you using an extension cord?**  
Do not use an extension cord.
- **Has a household fuse blown, or has a circuit breaker tripped?**  
Replace the fuse, or reset the circuit breaker.
- **Are both the hot and cold water faucets turned on?**  
Turn on the water.
- **Is the water inlet hose kinked?**  
Straighten the hoses.
- **Are the water inlet valve screens clogged?**  
Turn off the water and remove inlet hoses from the washer. Remove any accumulated film or particles. Reinstall hoses, turn on water and check for leaks.
- **Is the washer in a normal pause in the cycle?**  
The washer pauses for about 2 minutes during certain cycles. Allow the cycle to continue. Some cycles feature periods of tumbling and soak.
- **Is the washer overloaded?**  
Wash smaller loads.
- **Is the washer door firmly shut?**  
The door must be closed during operation.

- **Are the shipping bolts removed?**  
All four shipping bolts must be removed for proper operation of the washer.
- **Has a cycle been selected, but START has not been selected and held for 1 second?**  
Press and hold START, for 1 second.
- **Was the door open after completion of last cycle?**  
The door must be opened and closed again to start a new cycle.

---

### WASHER CONTINUES TO FILL OR DRAIN, DRAIN CYCLE SEEMS STUCK

---

- **Is the top of drain hose lower than 30" (76 cm) on washer?**  
The top of the drain hose must be at least 30" (76 cm) above the floor. See "Drain System."
- **Does the drain hose fit too tightly in the standpipe, or is it taped to the standpipe?**  
The drain hose should be loose yet fit securely. Do not seal the drain hose with tape. The hose needs an air gap. See "Secure the Drain Hose."

---

### WASHER WON'T DRAIN OR SPIN, WATER REMAINS IN WASHER

---

- **Is the drain hose clogged, or the end of the drain hose more than 96" (2.4 m) above the floor?**
- **Is the voltage low?**  
Check electrical source or call electrician.
- **Excessive suds?**  
When excessive suds are detected, a special suds routine automatically starts. Cycle will complete once extra suds are removed. This will occur more frequently when a non-HE detergent is used.
- **Is the load balanced?**  
A single or bulky item may cause imbalance. Add more items or redistribute the load.

---

### NOT ENOUGH WATER / NOT ENOUGH SUDS

---

- **Low water?**  
This washer uses very little water to provide good cleaning results. You will see little or no water splashing in this washer. This is normal.
- **Are you using HE detergent?**  
HE detergent is a low sudsing detergent. This is normal and will not affect cleaning performance.

---

## WASH / RINSE TEMPERATURE

---

- **Are the hot and cold water inlet hoses reversed?**  
See “Connect the Inlet Hoses.”
- **Are you washing many loads?**  
As your frequency of loads washed increases, the water temperature may decrease for hot and warm temperatures. This is normal.

---

## CYCLE TIME CHANGES/CYCLE TOO LONG

---

- **Estimated cycle time?**  
The cycle times vary automatically based on your water pressure, water temperature, detergent, and clothes load. The cycle time will be extended if oversudsing occurs or the load is unbalanced. The SUDs routine removes extra suds and assures proper rinsing of your garments. The options you select will also affect the cycle times that are shown in the Preset Cycle Settings table.
- **Excessive suds?**  
When excessive suds are detected, a special suds routine automatically starts. This routine will add time to the original cycle.
- **Did the load cause imbalance?**  
When too much imbalance occurs, an imbalance routine will start to redistribute the load. During the imbalance routine the time displayed may pause until this activity is complete, then resume with the remainder of the cycle.
- **Are you washing a single item or bulky load?**  
Spin time is added if an unbalanced load is detected. The washer will attempt to redistribute the load with additional tumbling.
- **Did you wash a large load on the Quick Wash cycle?**  
The Quick Wash cycle is designed for smaller load sizes (2-3 items) of lightly soiled garments. If larger loads are washed in this cycle, wash time will be increased.
- **Did you wash a large load in a gentle or Delicate cycle?**  
When using the Quick Wash or Delicate cycles, you should use small loads. This ensures a gentle wash for your garments without increasing cycle times.

---

## CLOTHES CARE

---

---

### LOAD TOO WET

---

- **Did you use the right cycle for the load being washed?**  
Select a cycle with a higher spin speed.
- **Did you wash a single item or bulky items or have you overloaded the washer?**  
A single item, bulky items, or overloading may cause imbalance. Add items or try to evenly distribute your wet laundry in the drum, and start a Drain/Spin cycle. If the laundry is still wet, take half of the load out of the washer and try again.
- **Did you use HE detergent?**  
Suds during rinse and spin cycles can reduce spin speed. Use HE detergent.

---

### RESIDUE, LINT, STAINS ON LOAD; GRAY WHITES, DINGY COLORS

---

- **Did you add detergent to the dispenser?**  
For best results, add detergent to the detergent compartment. Do not add detergent to the washer drum.
- **Did you sort properly?**  
Sort lint givers (towels, chenille) from lint takers (corduroy, synthetics). Dye transfer can occur when mixing whites and colors in a load. Sort dark clothes from whites and lights.
- **Did you overload the washer?**  
Do not overload the washer. The washer can be fully loaded, but not tightly packed. The wash load must be balanced. Lint can be trapped in the load if overloaded.
- **Check the following:**  
Was paper or tissue left in pockets?
- **Did you use enough HE detergent?**  
Follow manufacturer’s recommendations for the type of load you are washing. For best performance, use only High Efficiency detergent. Use enough HE detergent to remove soil and hold it in suspension.
- **Do you have hard water?**  
Use more detergent for washing heavy soils in cold or hard water.
- **Is the water colder than 60°F (15.6°C)?**  
Wash water colder than 60°F (15.6°C) may not completely dissolve the detergent. Use hot or warm washes if safe for the fabric load. Make sure your hot water system is adequate to provide a hot water wash.

- **Are you using a low speed wash cycle?**  
Powdered detergents may not dissolve well in a slow-speed cycle. For best results, use liquid detergent for slow-speed cycles such as Delicate.
- **Did you unload the washer promptly?**  
To avoid dye transfer, unload the washer as soon as it stops.
- **Did you use a fabric softener dispensing ball?**  
Dispensing balls will not operate correctly with this washer. Add liquid fabric softener to the fabric softener compartment.
- **Did you use powdered detergent in a low-speed cycle?**  
Consider using liquid detergent.
- **Did you use Quick Wash on a large load?**  
For best results, use Quick Wash for small, lightly soiled loads.

---

**LOAD IS WRINKLED, TWISTED, TANGLED**

---

- **Did you unload the washer promptly?**  
Unload the washer as soon as it stops.
- **Did you use the right cycle for the load being washed?**  
Use the Delicate cycle or another cycle with a low spin speed to reduce wrinkling.
- **Did you overload the washer?**  
The wash load must be balanced and not overloaded. Loads should tumble freely during washing.
- **Was the wash water warm enough to relax wrinkles?**  
If safe for load, use warm or hot wash water.
- **Are the hot and cold water hoses reversed?**  
Check that the hot and cold water hoses are connected to the right faucets. A hot rinse followed by spin will cause wrinkling. See “Connect the Inlet Hoses.”

— NOTES —



# COMPONENT ACCESS

This section instructs you on how to service each component inside the Duet Sport™ Front-Loading Automatic Washer. The components and their locations are shown below.

## COMPONENT LOCATIONS

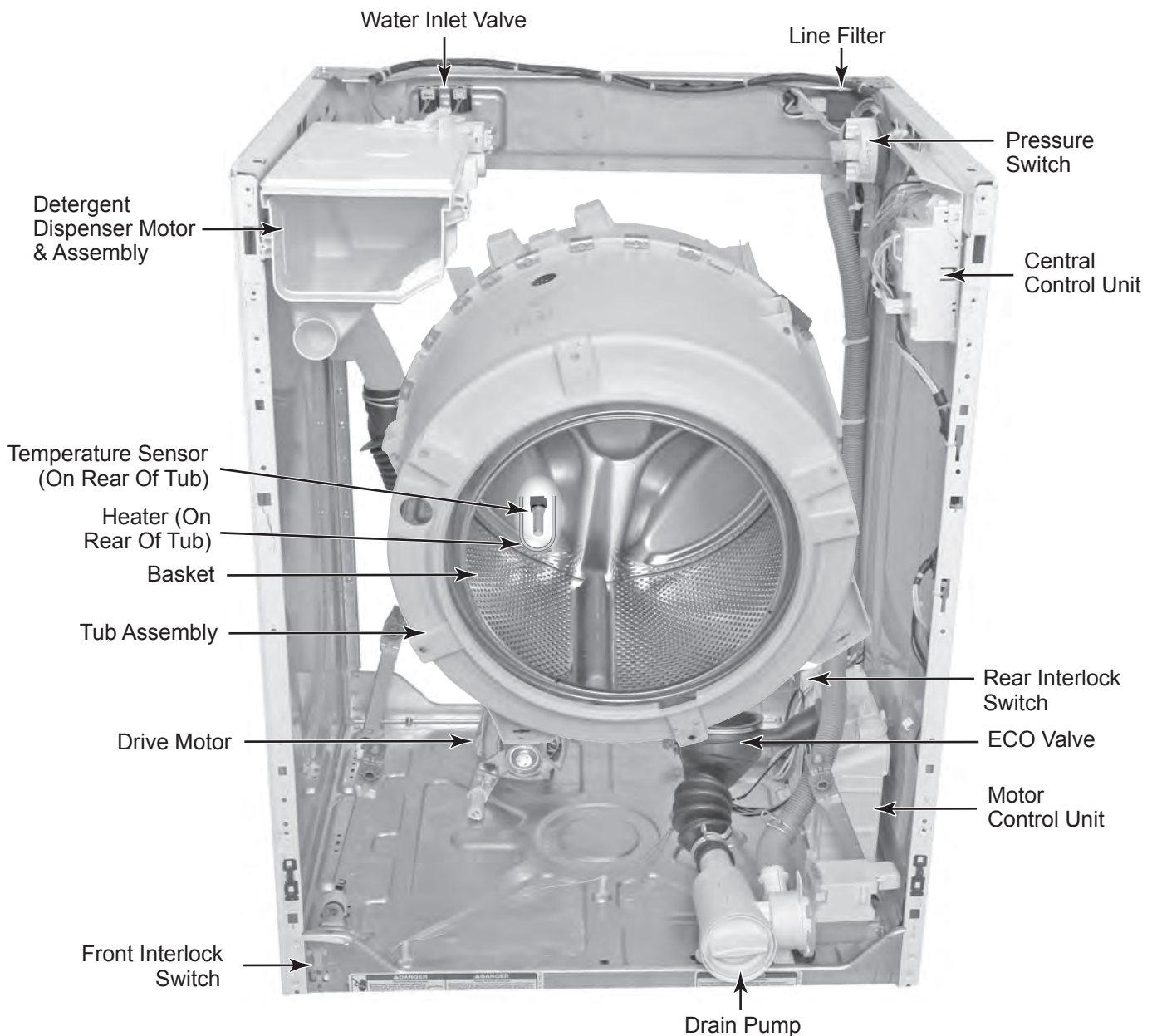

Not Shown: Console,  
Touchpad/LED Assembly, &  
Door Switch Assembly



# REMOVING THE CONSOLE AND THE TOUCHPAD/LED ASSEMBLY

## ⚠ WARNING



### Electrical Shock Hazard

Disconnect power before servicing.  
Replace all parts and panels before operating.

Failure to do so can result in death or electrical shock.

1. Unplug washer or disconnect power.
2. Turn off the water supply to the washer.
3. Remove the three T-20 hex-head Torx screws from the top cover of the washer.
4. Pull back on the cover and release the tabs in the console from the slots in the cover, then lift the cover off the unit.

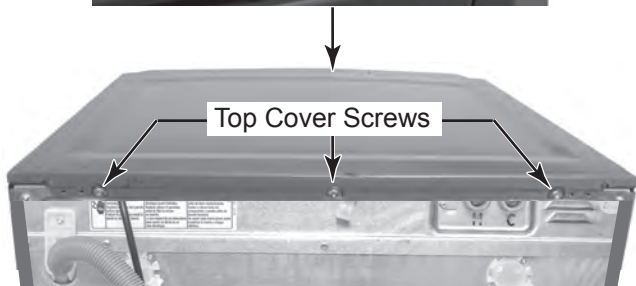
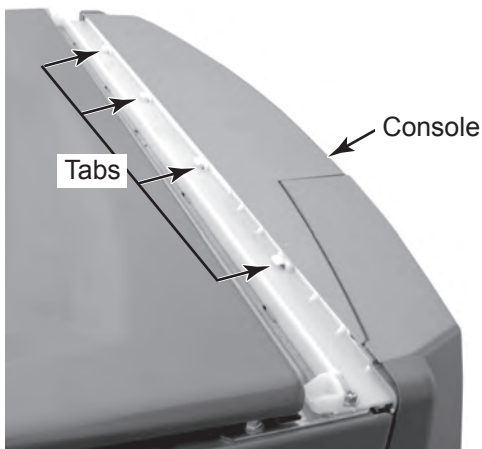

### 5. To remove the console:

- a) Pull out and disconnect cable connector U18 from the central control unit.
- b) Remove the cable wires from the two central control unit clips.

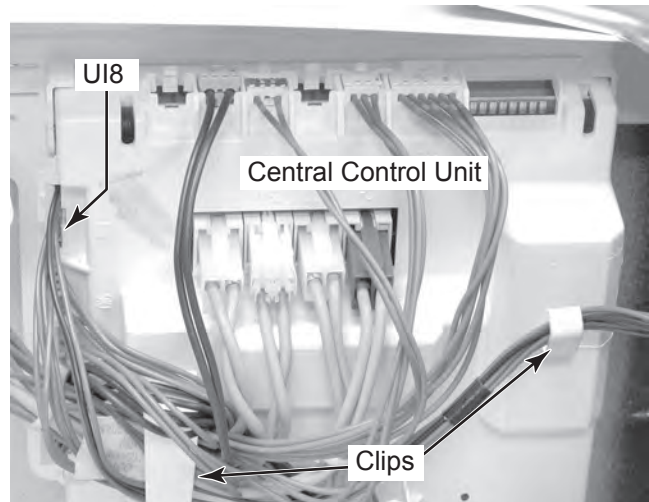

- c) Pull the detergent dispenser drawer out as far as it will go, then press down on the release tab, and remove the drawer from the unit.



- d) Remove the two screws at the recessed hole and bottom of the console.

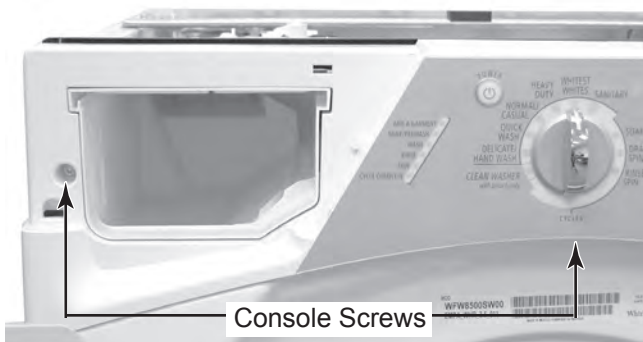

- e) Lift the top edge of the console and unhook it from the holder clips.

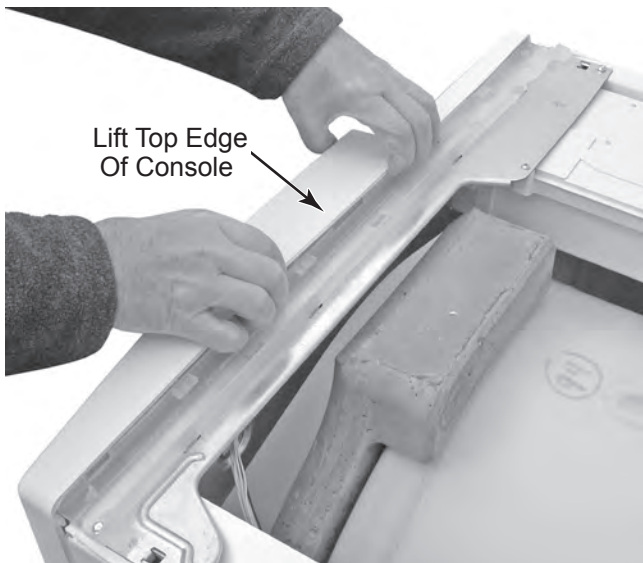

- f) Press the locking tab on the right rear side of the console inward, and remove the console.

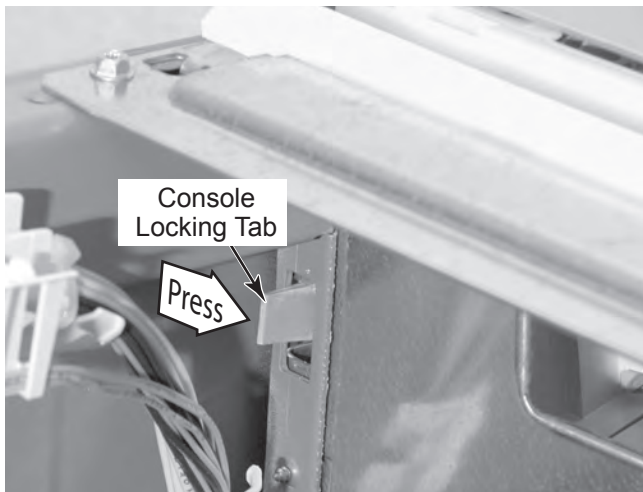

6. **To remove the touchpad/LED assembly:**

- a) Pull the selector knob off the switch shaft.  
 b) Press the seven console locking tabs, and unsnap the touchpad/LED assembly, then lift the assembly from the console and remove it.

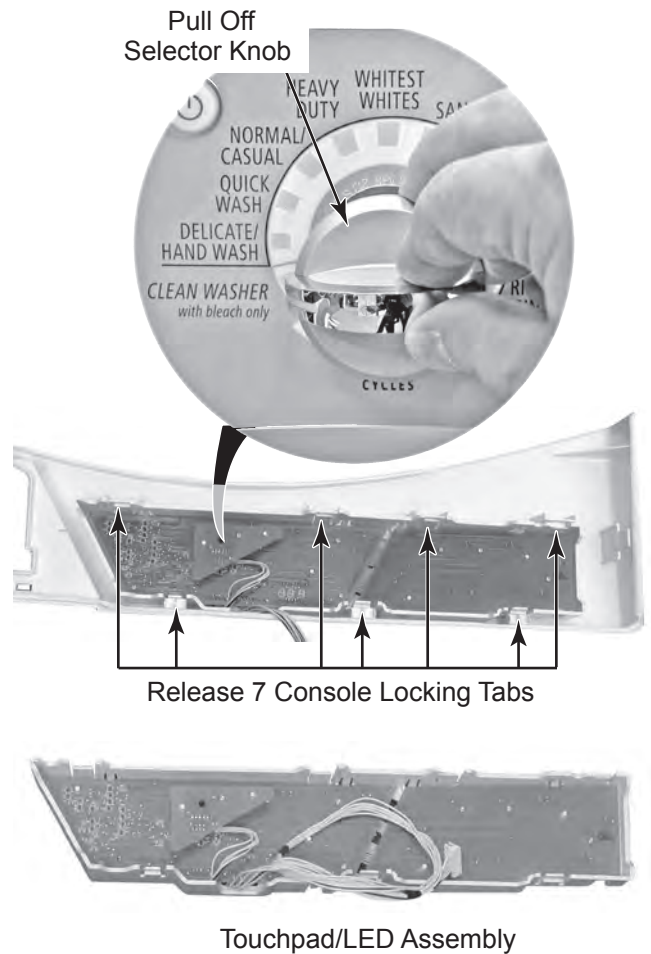

## REMOVING THE CENTRAL CONTROL UNIT

### **⚠ WARNING**



#### **Electrical Shock Hazard**

**Disconnect power before servicing.**

**Replace all parts and panels before operating.**

**Failure to do so can result in death or electrical shock.**

1. Unplug washer or disconnect power.
2. Turn off the water supply to the washer.
3. Remove the top cover from the washer (see page 4-2 for the procedure).



Central Control Unit

4. Pull the wire connectors off the edges of the central control unit circuit board (see the top right photo). When you pull an edge connector off the board, first pry the locking tab away from the connector with a small screwdriver blade to release it.
5. Slide the hooked ends of the two wire clamps off the locking tabs, and remove the wires from the clamps.

Central Control Unit Connectors (12)

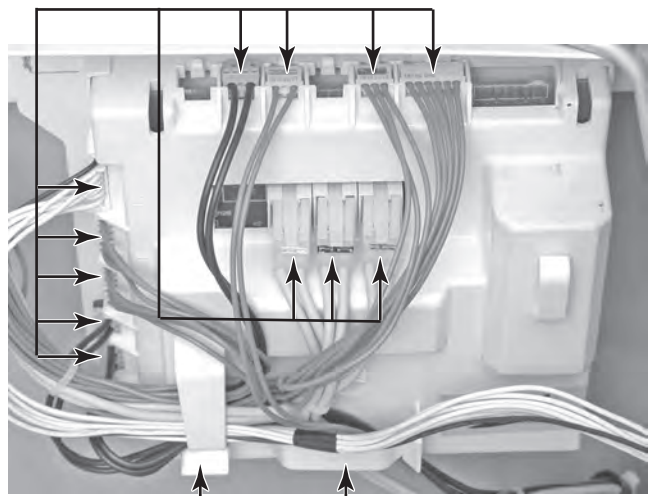

Wire Clamps

6. Pry up on the locking tab, and push the central control unit (CCU) toward the rear of the washer as far as it will go, and remove the CCU tabs from the keyhole slots in the chassis.

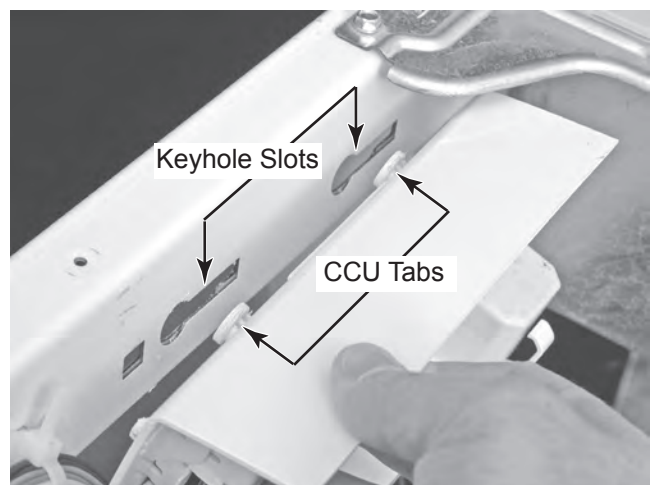
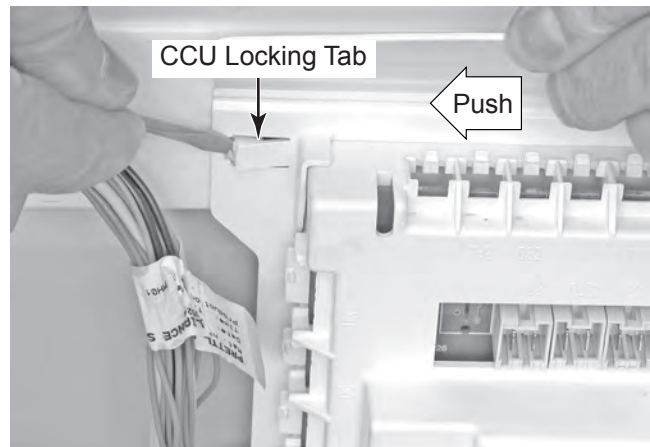

**REASSEMBLY NOTE:** The photo shows the connector callouts for the central control unit.

Make sure that you seat the connectors firmly onto the circuit board, and that they lock securely into place.

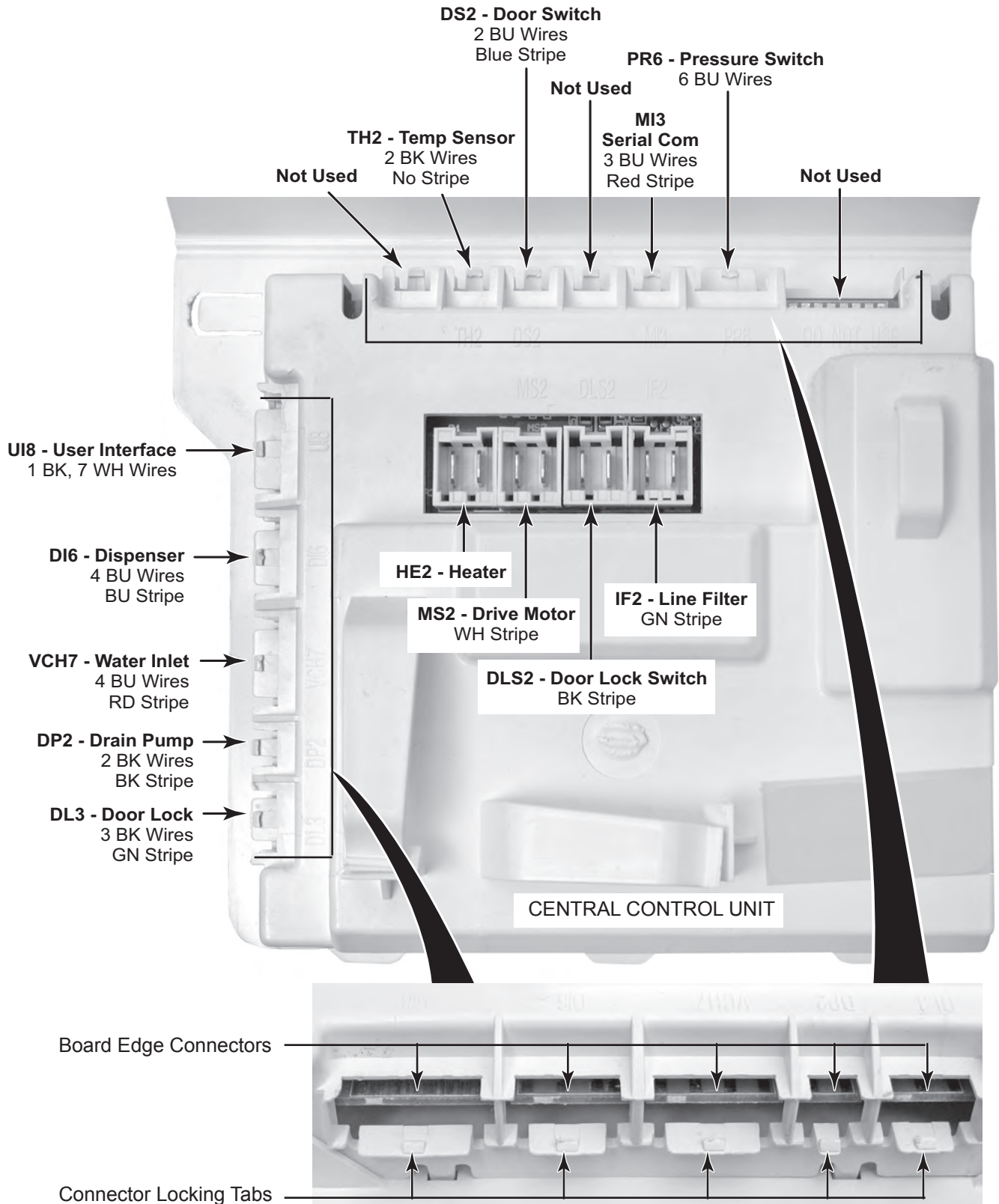



# REMOVING THE WATER INLET VALVE

## ⚠ WARNING



### Electrical Shock Hazard

Disconnect power before servicing.

Replace all parts and panels before operating.

Failure to do so can result in death or electrical shock.

1. Unplug washer or disconnect power.
2. Turn off the water supply to the washer.
3. Remove the water hoses from the hot and cold water inlet valve.
4. Remove the top cover (see page 4-2 for the procedure).

Water Inlet Valve



5. Lift the locking tabs with a small-blade screwdriver (see the top right photo), and pull the wire connectors out of the hot and cold water inlet valve solenoid terminal holders. **NOTE:** The cold water wire connector has a black stripe on it.
6. Loosen the clamp, and pull the water inlet hose off the water inlet valve.

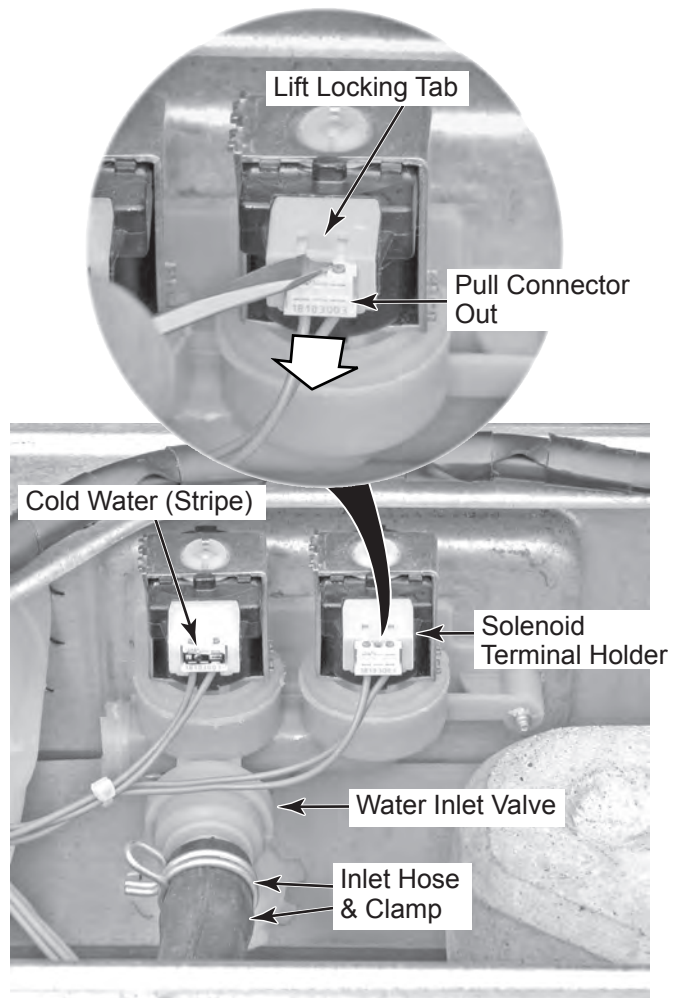

7. At the rear of the washer, remove the screw from the water inlet valve. Slide the valve to the right, and push it into the washer off the rear panel.

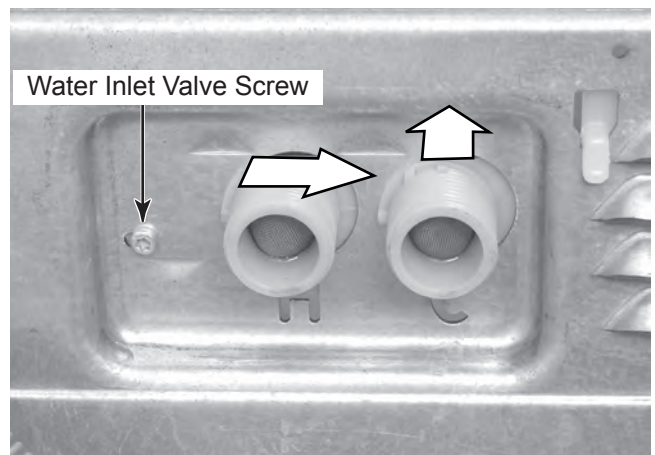

## REMOVING THE PRESSURE SWITCH

### **⚠ WARNING**



#### **Electrical Shock Hazard**

**Disconnect power before servicing.**

**Replace all parts and panels before operating.**

**Failure to do so can result in death or electrical shock.**

1. Unplug washer or disconnect power.
2. Turn off the water supply to the washer.
3. Remove the top cover from the washer (see page 4-2 for the procedure).

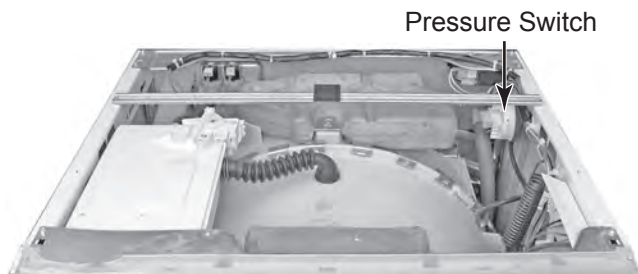

4. Press and release the two wire connector locking arms and pull the connector off the pressure switch.
5. Pull the pressure hose off the pressure switch fitting.

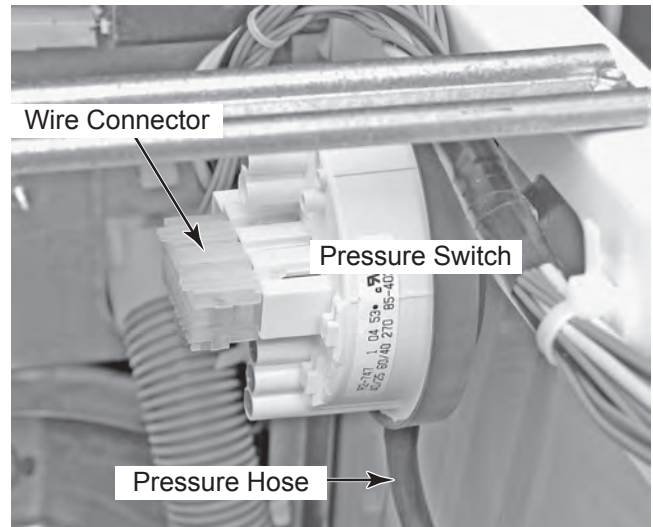

6. Turn the pressure switch 90° in a clockwise (CW) direction, and align the key on the switch with the slot in the chassis, then remove the switch from the washer.

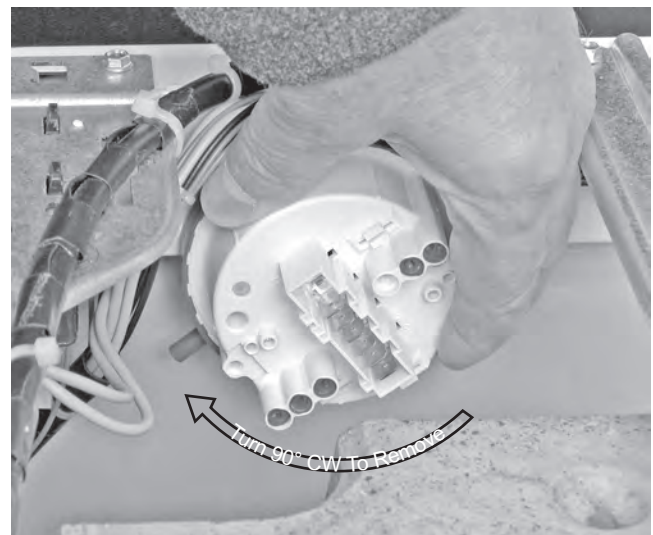

# REMOVING THE LINE FILTER & POWER SUPPLY CORD

## ⚠ WARNING



### Electrical Shock Hazard

Disconnect power before servicing.

Replace all parts and panels before operating.

Failure to do so can result in death or electrical shock.

1. Unplug washer or disconnect power.
2. Turn off the water supply to the washer.
3. Remove the top cover from the washer (see page 4-2 for the procedure).

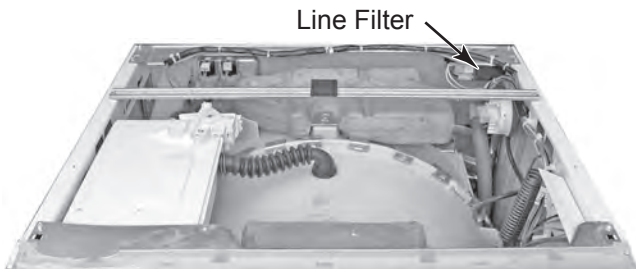

4. **To remove the line filter:**
  - a) Remove the T-20 Torx/hex-head screw from the line filter.
  - b) Position the line filter so that the four tabs are aligned with the chassis slots and remove the filter from the washer.

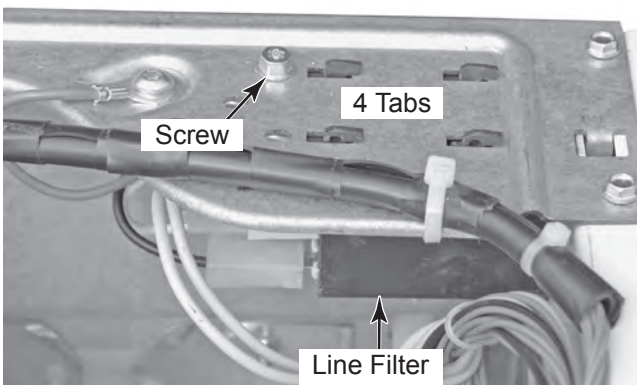

- c) Disconnect the three wire connectors from the line filter. **NOTE:** Press and release the locking arm on the 2-wire connector to disconnect it from the filter.

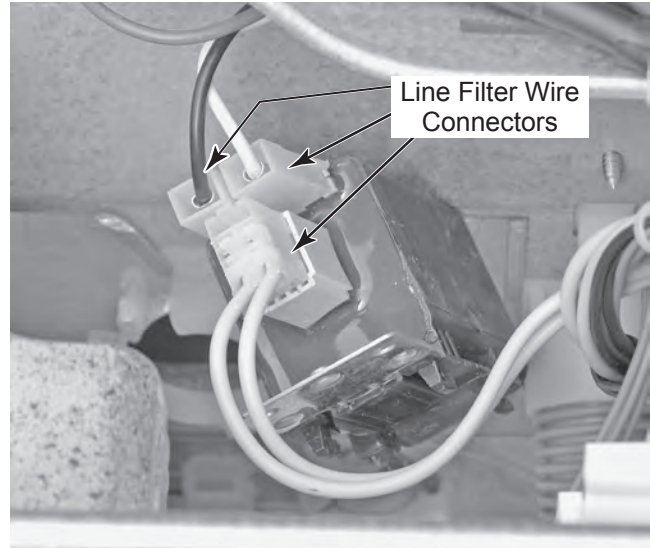

5. **To remove the power supply cord:**
  - a) Remove the screw from the green ground wire.
  - b) Pull the connectors with the white and black wires from the line filter terminals.

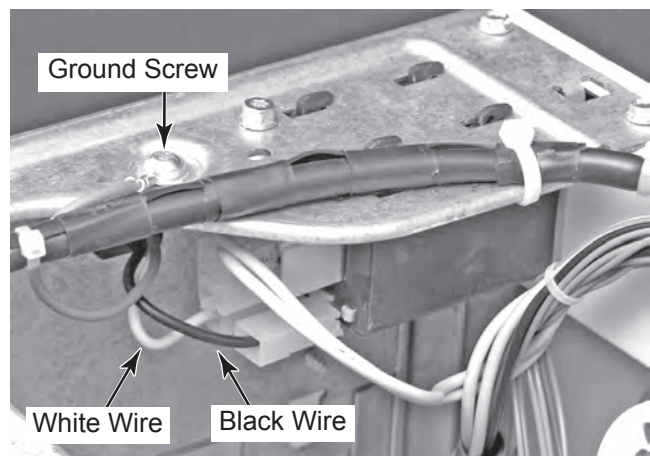



- c) Pull the washer away from the wall far enough to access the power supply cord on the rear panel.
- d) Use a pair of pliers and turn the strain relief on the power supply cord 90° in either direction. Align the strain relief key with the slot in the rear panel, and remove the cord from the washer.

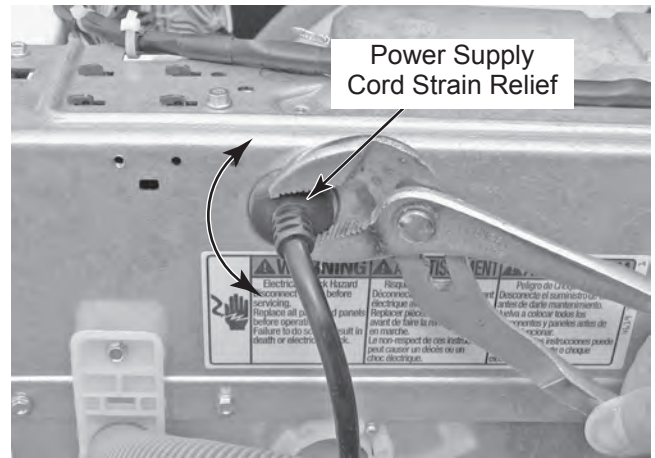

# REMOVING THE DETERGENT DISPENSER ASSEMBLY

## ⚠ WARNING



### Electrical Shock Hazard

Disconnect power before servicing.

Replace all parts and panels before operating.

Failure to do so can result in death or electrical shock.

1. Unplug washer or disconnect power.
2. Turn off the water supply to the washer.
3. Remove the top cover from the washer (see page 4-2 for the procedure).



Detergent Dispenser

4. Remove the console from the washer (see step 5 on page 4-2 for the procedure).
5. Remove the detergent dispenser screws from the front and top of the washer.
6. Loosen the clamp and remove the tub-to-dispenser vent tube from the dispenser.

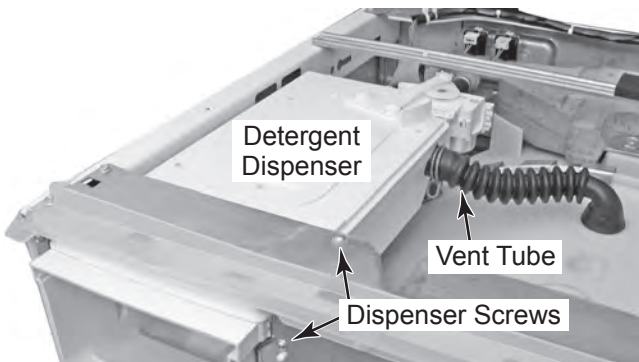

7. Remove the left hex-head screw from the support bracket.
8. Loosen the clamp and remove the water supply tube from the detergent dispenser.

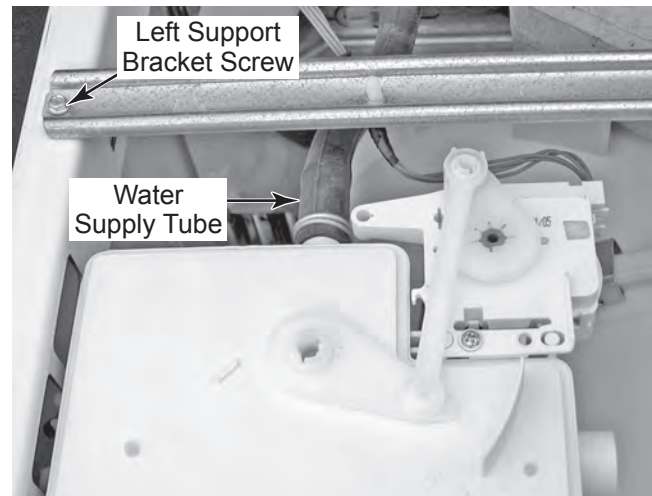

9. Lift the locking tabs and remove the two wire connectors from the detergent dispenser motor terminals. When you reconnect the wire connectors, note that the top connector has a blue stripe on it.

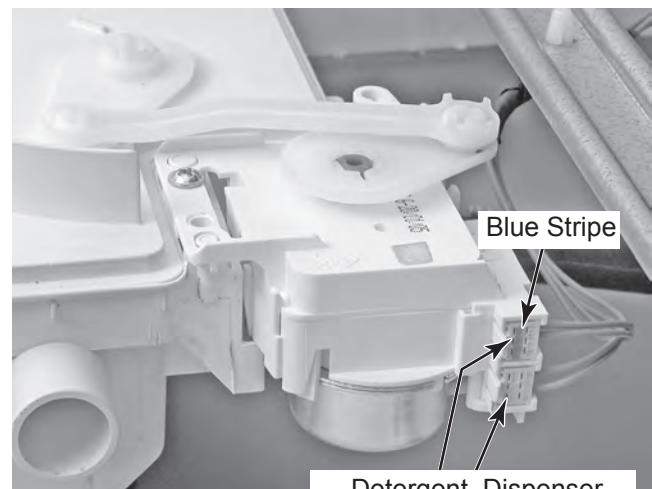

10. Remove the three hex-head screws from the lower front access panel, then lower the panel, and remove it.

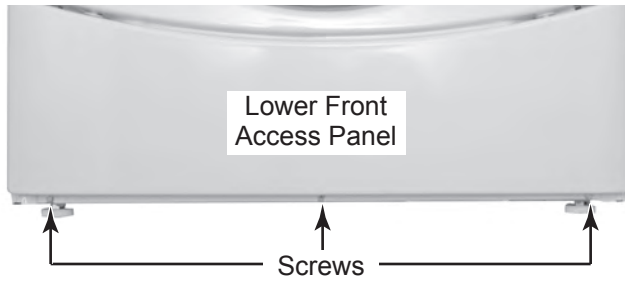

11. Open the washer door.

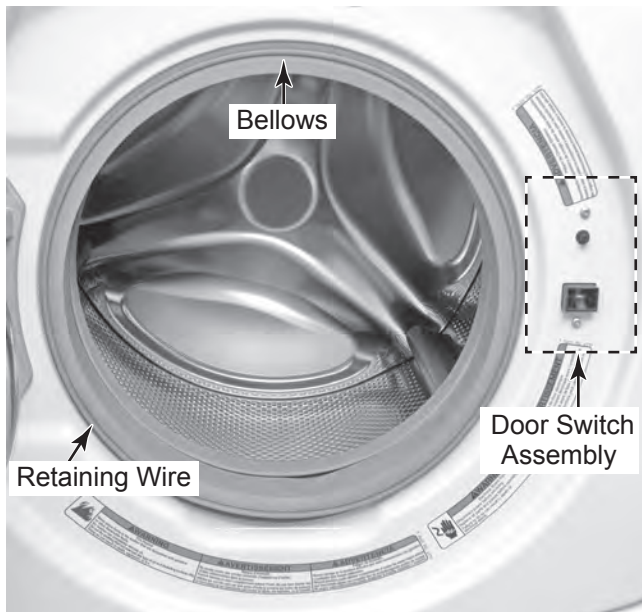

12. Using a small screwdriver or a pair of long-nosed pliers, pull the tension spring on the retaining wire out from around the front of the bellows, and remove the wire.

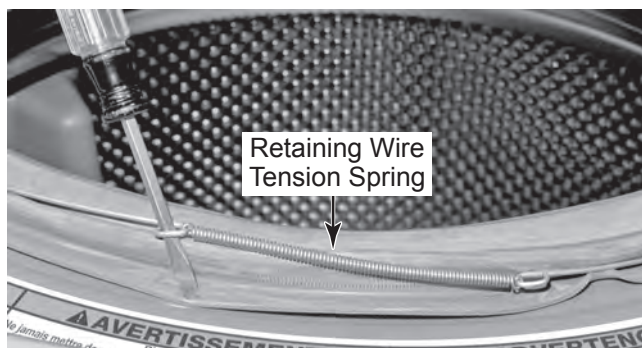

13. Pull the bellows off the lip of the front panel, and push the bellows inside the front panel.
14. Remove the two T-20 Torx screws from the door switch assembly.

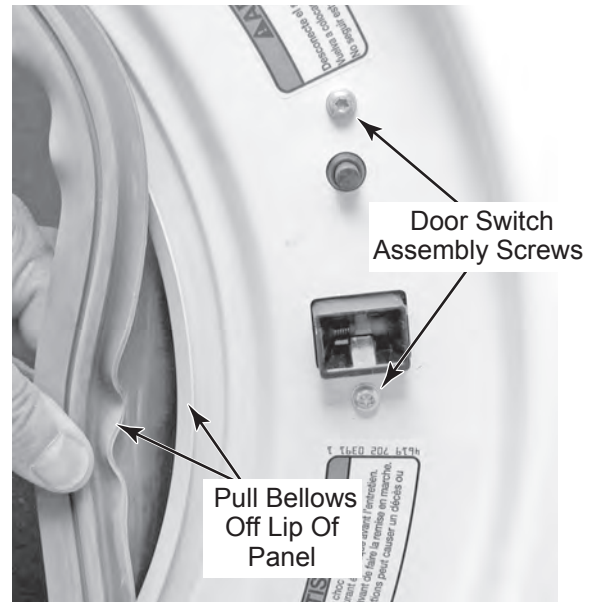

15. Close the washer door.
16. Remove the four hex-head screws from the top and bottom of the front panel and remove the panel from the unit.



**Continued on the next page.**

17. Loosen the clamp from the main water feed tube and remove the tube from the detergent dispenser.

**REASSEMBLY NOTE:** When you reconnect the water feed tube, align the arrow on the tube with the line on the detergent dispenser.

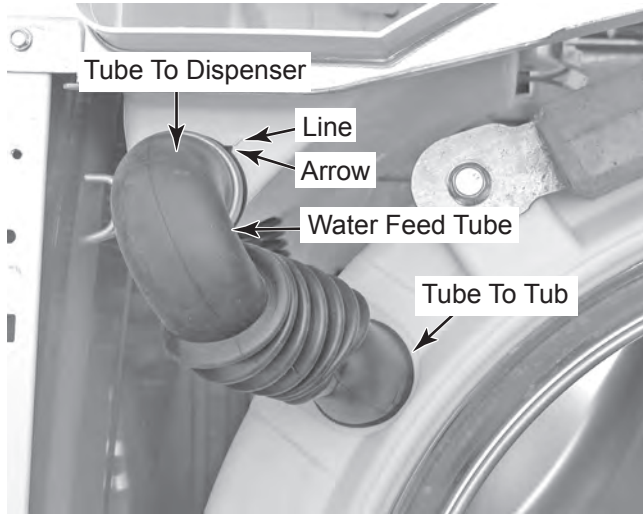

18. Pull back and unhook the tab on the left side of the detergent dispenser from the cabinet side panel slot, then lift the dispenser out of the washer.

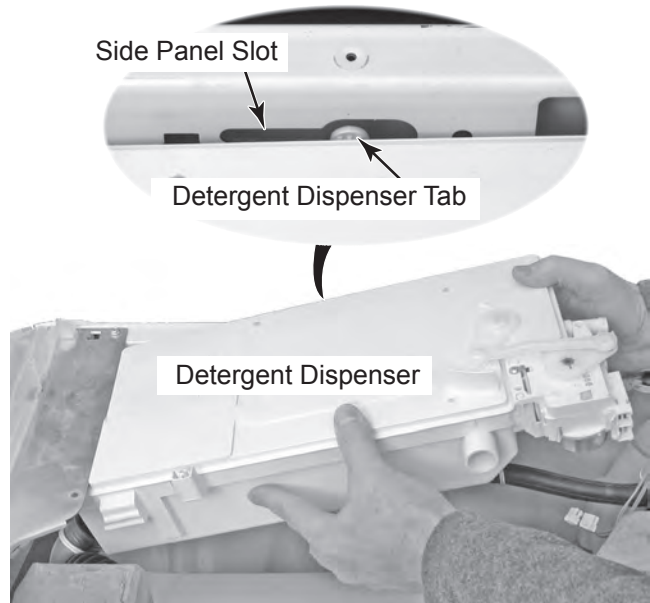



## REMOVING THE DETERGENT DISPENSER MOTOR

### **⚠ WARNING**



#### **Electrical Shock Hazard**

**Disconnect power before servicing.  
Replace all parts and panels before  
operating.**

**Failure to do so can result in death or  
electrical shock.**

1. Unplug washer or disconnect power.
2. Turn off the water supply to the washer.
3. Remove the top cover from the washer (see page 4-2 for the procedure).

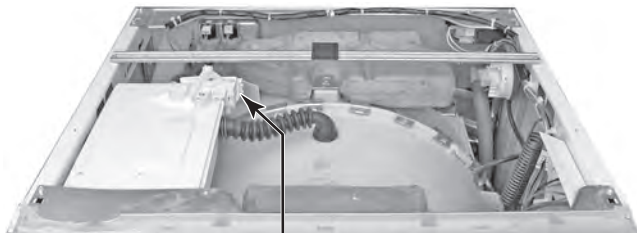

Detergent Dispenser Motor

4. Lift the locking tabs and remove the two wire connectors from the detergent dispenser motor terminals. **NOTE:** When you reconnect the wire connectors, make sure to position the connector with the blue stripe on top.
5. Pry up on the cam actuator and unsnap it from the motor shaft.
6. Remove the mounting screw from the detergent dispenser motor and remove the motor.

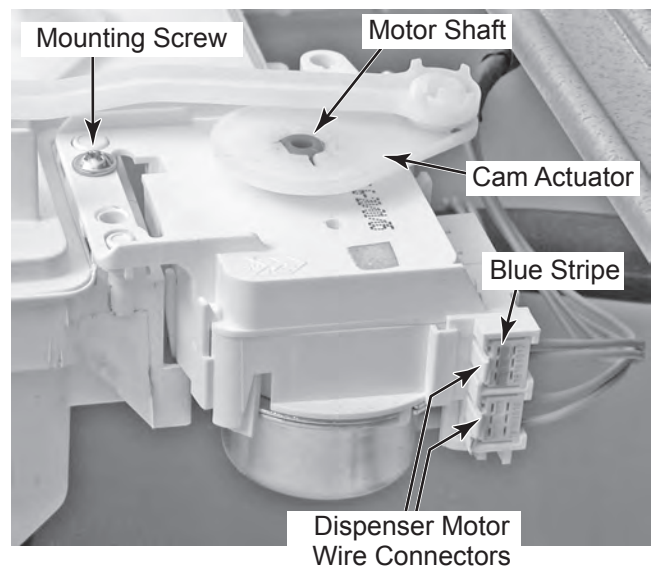

# REMOVING THE DOOR SWITCH ASSEMBLY AND THE BELLOWS

## ⚠ WARNING



### Electrical Shock Hazard

Disconnect power before servicing.

Replace all parts and panels before operating.

Failure to do so can result in death or electrical shock.

1. Unplug washer or disconnect power.
2. Turn off the water supply to the washer.
3. Remove the top cover and the console (see page 4-2 for the procedures).
4. Remove the lower front access panel (see step 10 on page 4-11 for the procedure).
5. Open the washer door.

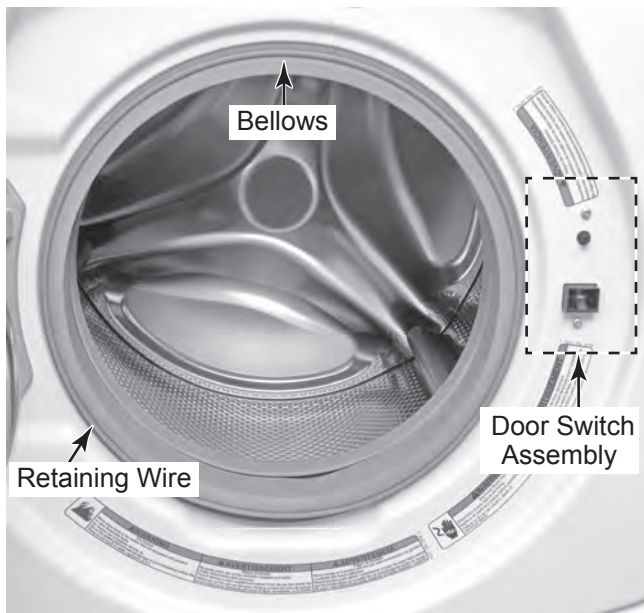

6. Using a small screwdriver or a pair of long-nosed pliers, pull the tension spring on the retaining wire out from around the front of the bellows, and remove the wire.

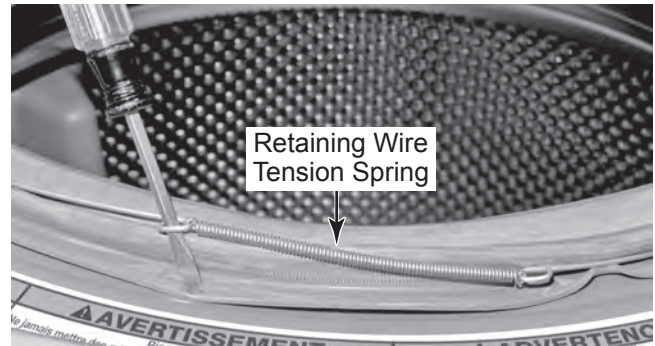

7. **To remove the door switch assembly:**
  - a) Pull the bellows off the lip of the front panel beside the door switch assembly just enough to access the switch assembly.
  - b) Remove the two T-20 Torx screws from the door switch assembly.

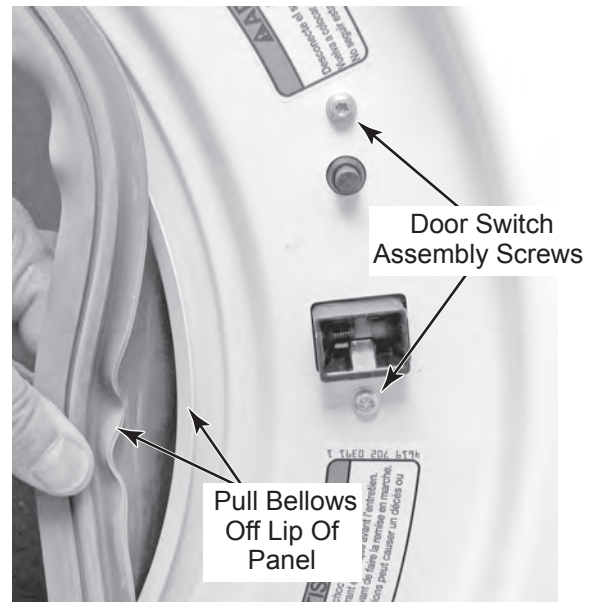

- c) Pull the door switch assembly out and turn it over so that you can access the connectors.
- d) Unlock the tabs and disconnect the three wire connectors from the door switch terminals, then remove the assembly.

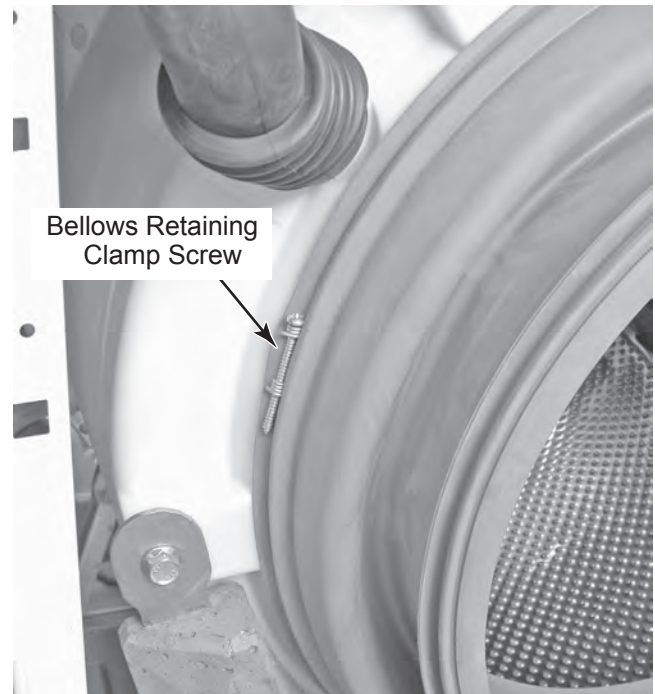
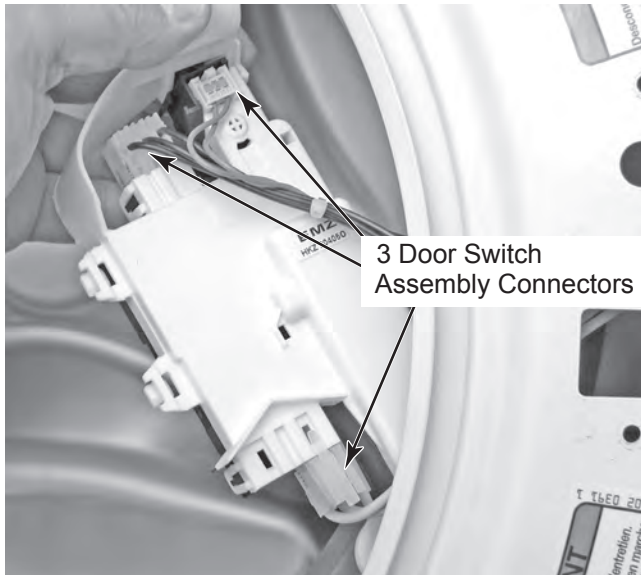

- d) Remove the bellows retaining clamp from around the bellows.

8. **To remove the bellows:**

- a) Remove the two T-20 Torx screws from the door switch assembly (see the photo in step 7b).
- b) Remove the front panel from the washer (see steps 15 and 16 on page 4-11 for the procedure).
- c) Turn the bellows retaining clamp screw counterclockwise until the clamp is loose enough to remove it from around the bellows (see the top right photo). **NOTE:** It may be necessary to completely remove the screw from one end of the clamp.



Continued on the next page.



e) Pull the bellows off the front of the tub.



**REASSEMBLY NOTE:** When you reinstall the bellows, be sure to position the “weep holes” at the bottom, as shown below.

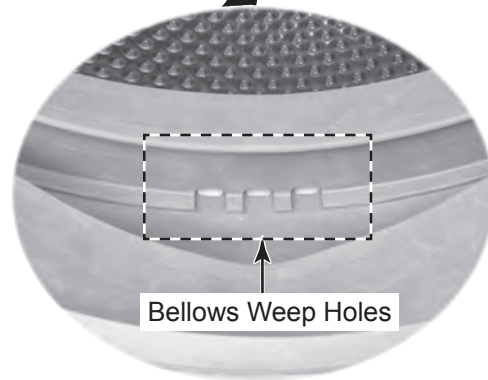
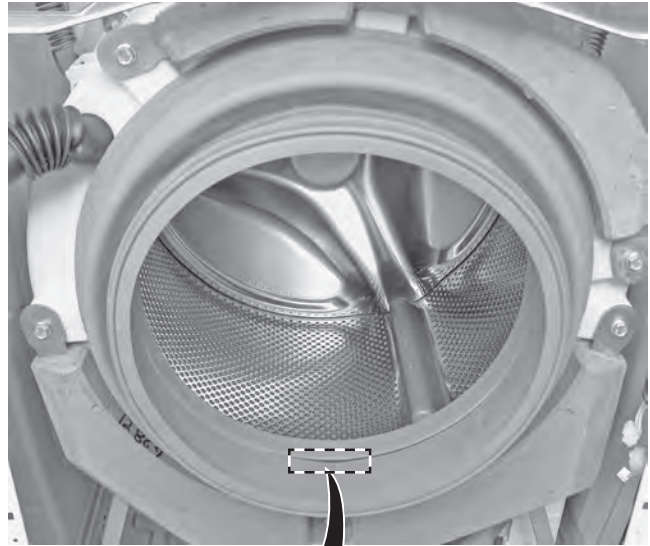

## REMOVING THE DRAIN PUMP

### **⚠ WARNING**



**Electrical Shock Hazard**  
**Disconnect power before servicing.**  
**Replace all parts and panels before operating.**  
**Failure to do so can result in death or electrical shock.**

1. Unplug washer or disconnect power.
2. Turn off the water supply to the washer.
3. Remove the lower front access panel (see step 10 on page 4-11 for the procedure).

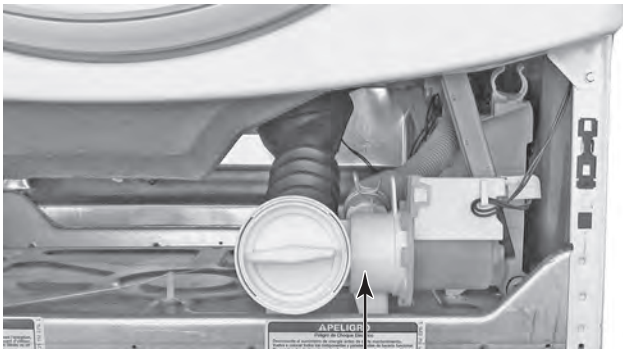

Drain Pump

4. Using a shallow pan to catch the water, unscrew the filter from the drain pump, and drain the water from the pump.

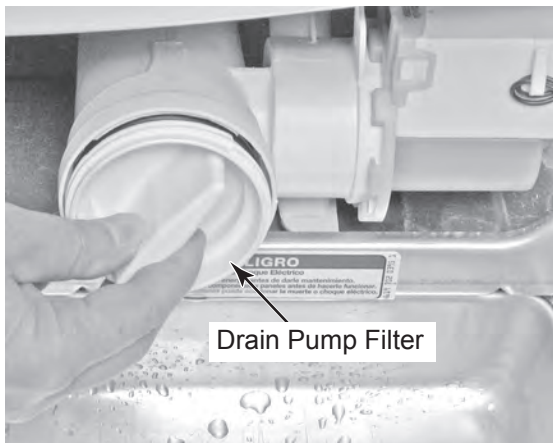

5. Loosen the clamp and remove the pump-to-tub hose from the drain pump.
6. Loosen the clamp and remove the pump-to-drain hose from the drain pump.

**REASSEMBLY NOTE:** When you reconnect the hoses, align their tab(s) with the marks on the drain pump.

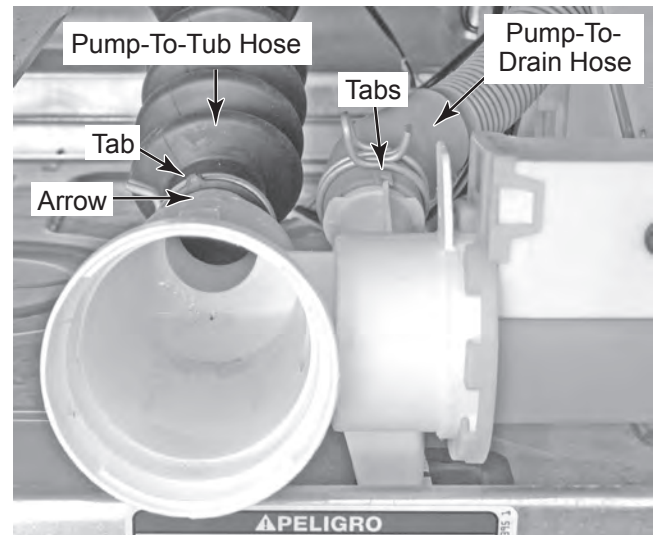

7. Using a flat-blade screwdriver, lift the rubber pad, and slide the pump to the left and unhook the bottom tab, then lift the pump out of the chassis floor slots.

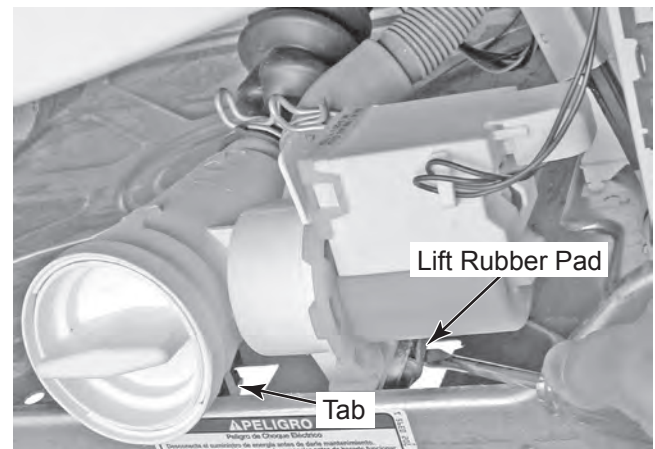

**Continued on the next page.**

8. Lift the wire cover on the drain pump, and disconnect the wire connector from the terminals.
9. Remove the wires from the clip, and remove the drain pump from the washer.

**REASSEMBLY NOTE:** When you reinstall the drain pump, make sure that you completely reset the rubber pad in its chassis floor slot.

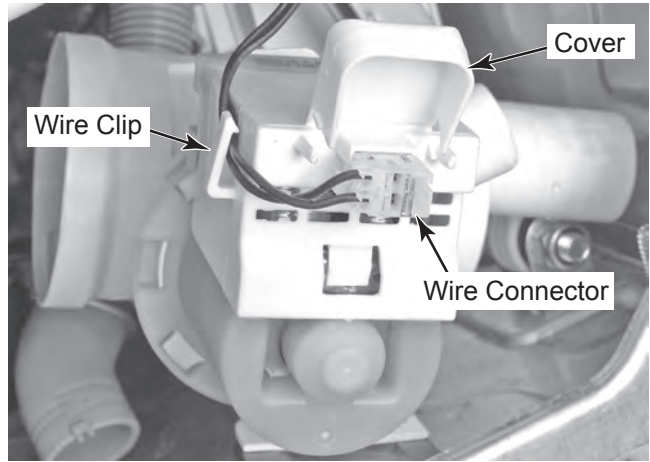

## REMOVING THE ECO VALVE

### **⚠ WARNING**



#### **Electrical Shock Hazard**

**Disconnect power before servicing.**

**Replace all parts and panels before operating.**

**Failure to do so can result in death or electrical shock.**

1. Unplug washer or disconnect power.
2. Turn off the water supply to the washer.
3. Remove the lower front access panel (see step 10 on page 4-11 for the procedure).

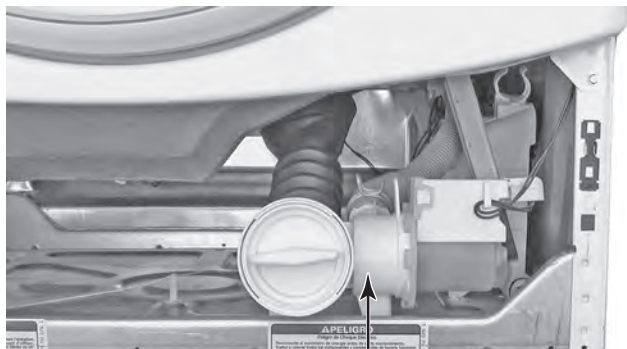

Drain Pump

4. Using a shallow pan to catch the water, unscrew the filter from the drain pump, and drain the water from the pump.

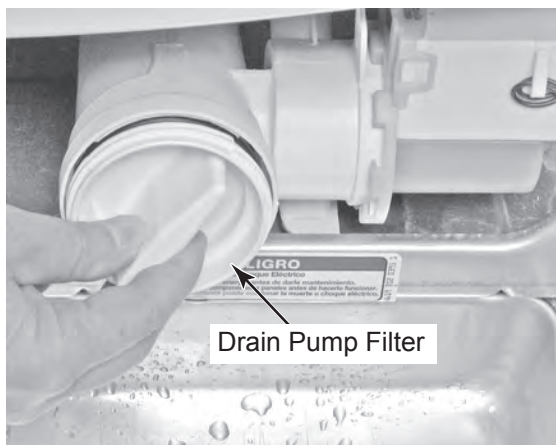

Drain Pump Filter

5. Pull the pressure hose off the air trap that is connected to the pump-to-tub/ECO valve hose.
6. Loosen the clamps at both ends of the pump-to-tub hose, and pull the hose/ECO valve off the tub and drain pump.

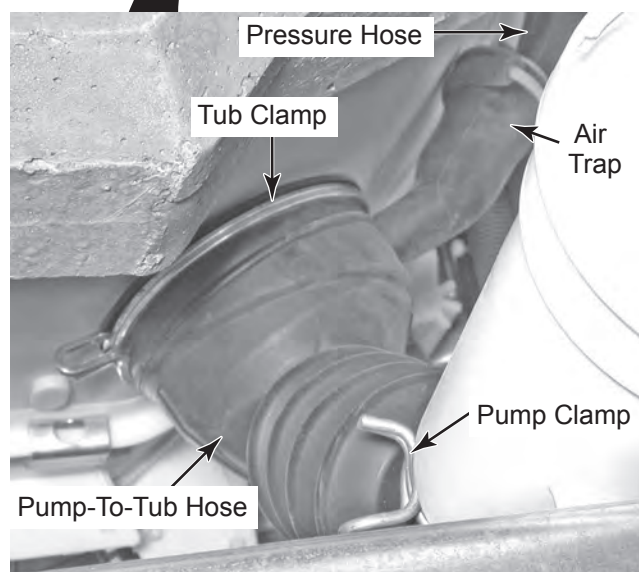

ECO Valve



# REMOVING THE MOTOR CONTROL UNIT

## ⚠️ WARNING



### Electrical Shock Hazard

Disconnect power before servicing.

Replace all parts and panels before operating.

Failure to do so can result in death or electrical shock.

1. Unplug washer or disconnect power.
2. Turn off the water supply to the washer.
3. Pull the washer away from the wall.
4. Remove the four plastic shipping bolt hole covers. To remove a cover, lift the rounded end to unhook the locking tab from the slot in the chassis, and slide the cover off the rear panel.
5. Remove the hex-head screws (arrows) from the rear panel.

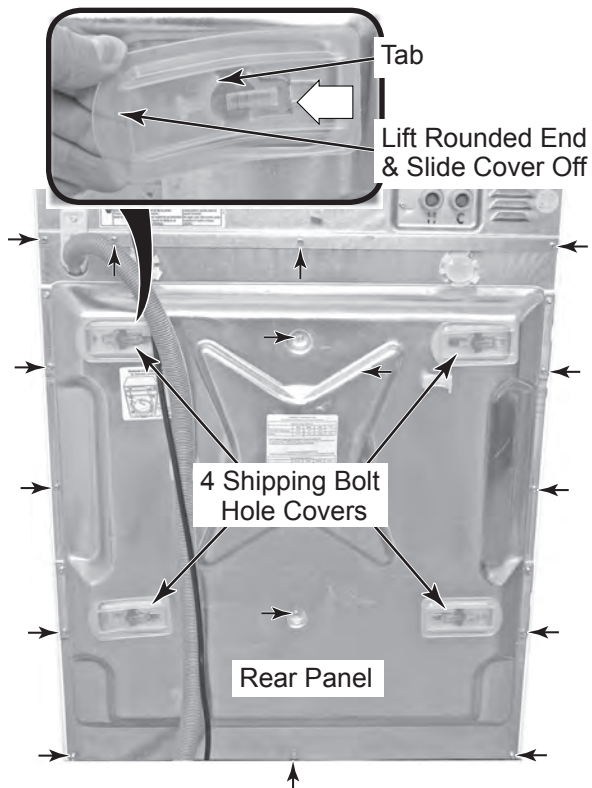

6. Pull the bottom of the rear panel out, and slide it down so the top edge is out from behind the lip of the upper panel, and remove the rear panel.

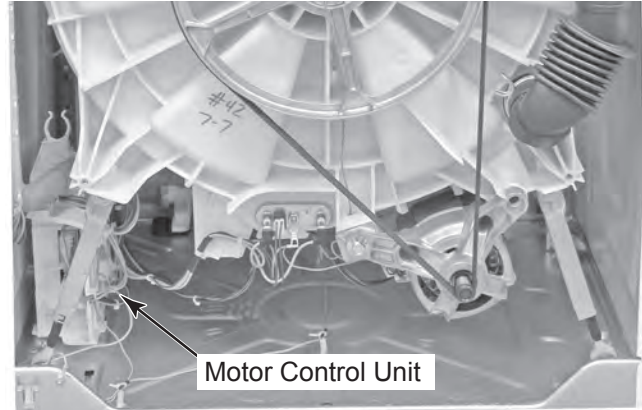

7. Pull the hose out of the holders on top of the motor control unit.
8. Remove the wire ties from the cover.
9. Use a flat-blade screwdriver, and pry the locking tab up on the bottom of the motor control unit to release it, then slide the unit forward to release the four tabs from the keyhole slots, and lift the motor control unit from the washer.

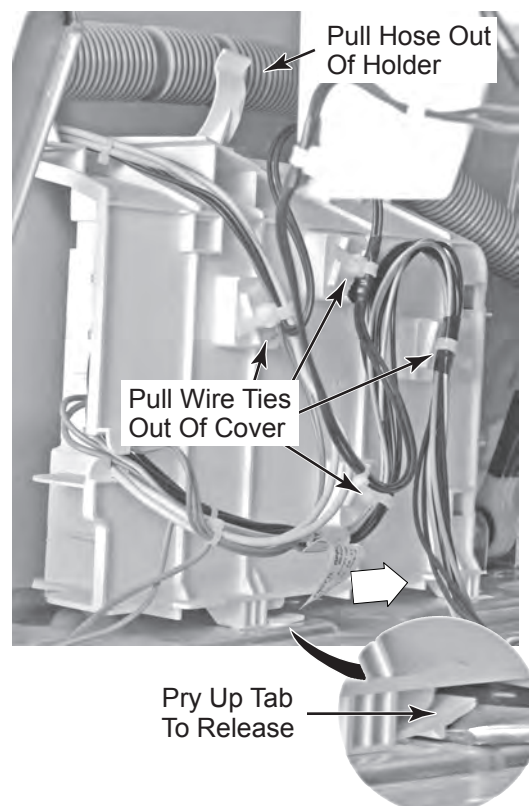

10. Disconnect the four wire connectors from the motor control unit and remove the unit.

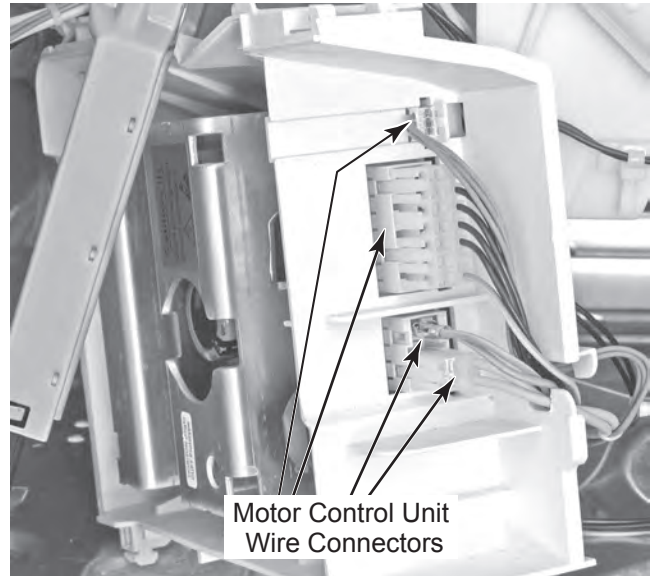

# REMOVING THE TEMPERATURE SENSOR & HEATER

## ⚠ WARNING



### Electrical Shock Hazard

Disconnect power before servicing.

Replace all parts and panels before operating.

Failure to do so can result in death or electrical shock.

1. Unplug washer or disconnect power.
2. Turn off the water supply to the washer.
3. Pull the washer away from the wall.
4. Remove the rear panel from the washer (see page 4-20 for the procedure).

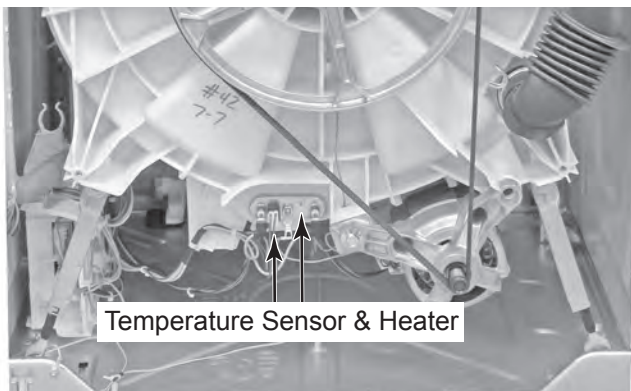

5. **To remove the temperature sensor:**
  - a) Disconnect the wire connector from the temperature sensor.

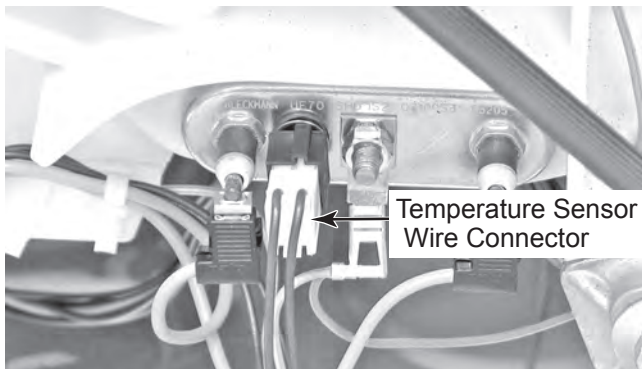

- b) Loosen the 10 mm nut and pull the temperature sensor out of the heater.

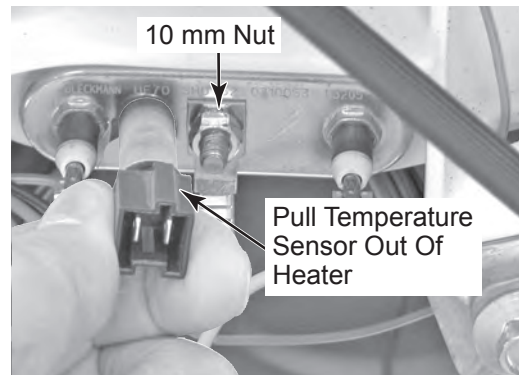

6. **To remove the heater:**
  - a) Remove the temperature sensor from the heater (see step 5).
  - b) Loosen (do not remove) the 10 mm nut on the heater.
  - c) Disconnect the two wires and the ground connector wire from the heater.

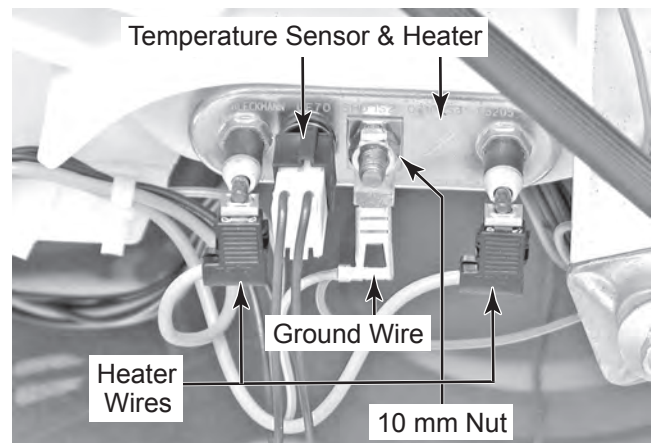

- d) Pull the heater out of the tub opening.

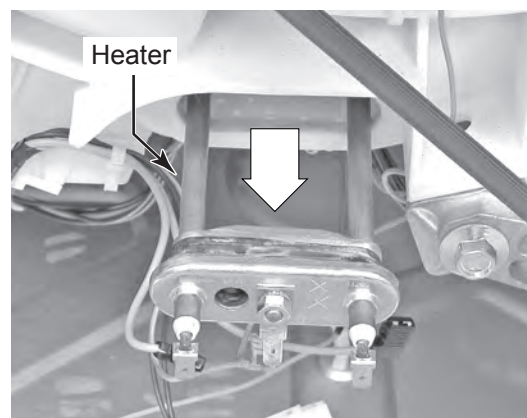



## REMOVING THE DRIVE BELT AND MOTOR

### ⚠ WARNING



#### Electrical Shock Hazard

Disconnect power before servicing.  
Replace all parts and panels before operating.

Failure to do so can result in death or electrical shock.

1. Unplug washer or disconnect power.
2. Turn off the water supply to the washer.
3. Pull the washer away from the wall.
4. Remove the rear panel from the washer (see page 4-20 for the procedure).

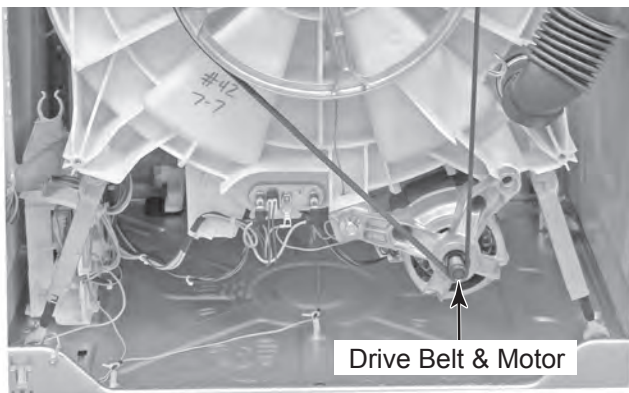

5. **To remove the drive belt**, pull out on the belt, and turn the basket drive pulley until the belt slides off (see the top right photo).

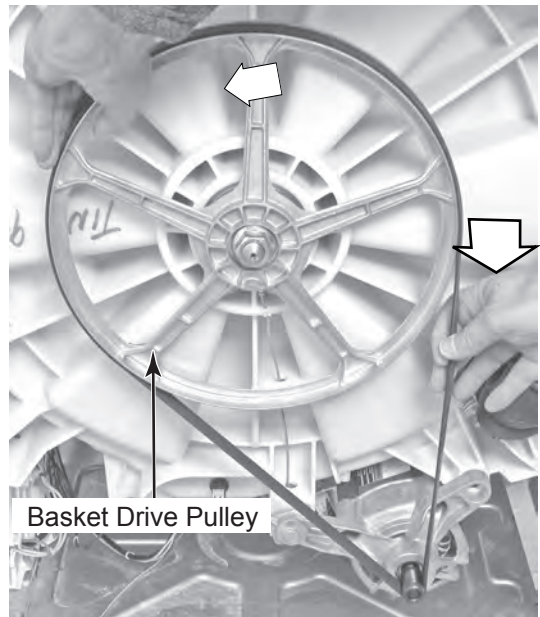

6. **To remove the motor:**
  - a) Remove the wire standoff from the motor by squeezing the tabs and pushing the standoff out of the mounting hole.
  - b) Disconnect the three wire connectors from the motor terminals.
  - c) Remove the 5/8" mounting bolt from the motor.

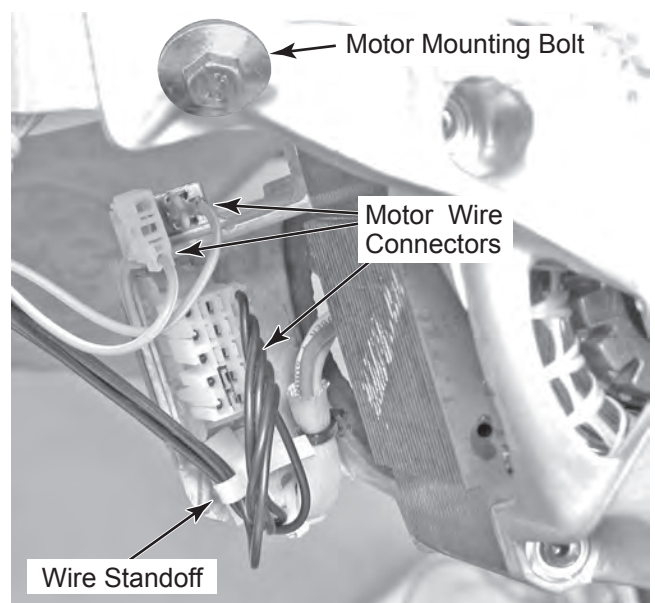

Continued on the next page.

- d) Rotate the motor down and pull it toward you so the bracket studs are out of the tub mounting holes, and remove the motor.

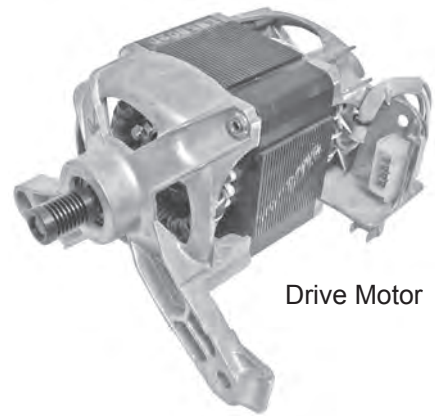
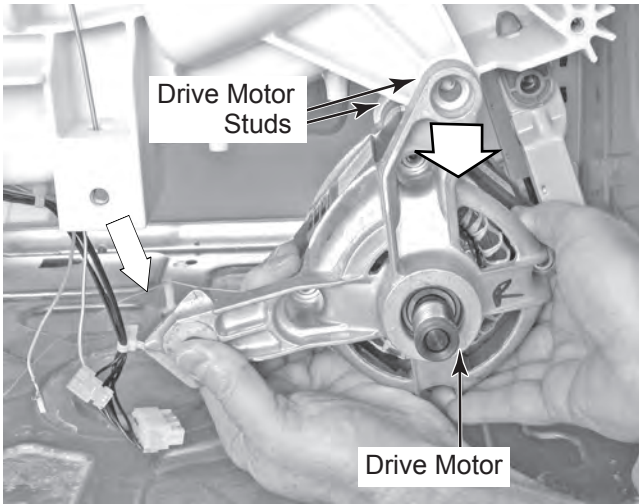

## REMOVING AN INTERLOCK SWITCH

### **⚠ WARNING**



**Electrical Shock Hazard**  
**Disconnect power before servicing.**  
**Replace all parts and panels before operating.**  
**Failure to do so can result in death or electrical shock.**

1. Unplug washer or disconnect power.
2. Turn off the water supply to the washer.
3. If you are servicing the rear interlock switch, pull the washer away from the wall, and remove the rear panel from the washer (see page 4-20 for the procedure).

If you are servicing the front interlock switch, remove the lower front access panel (see step 10 on page 4-11 for the procedure).

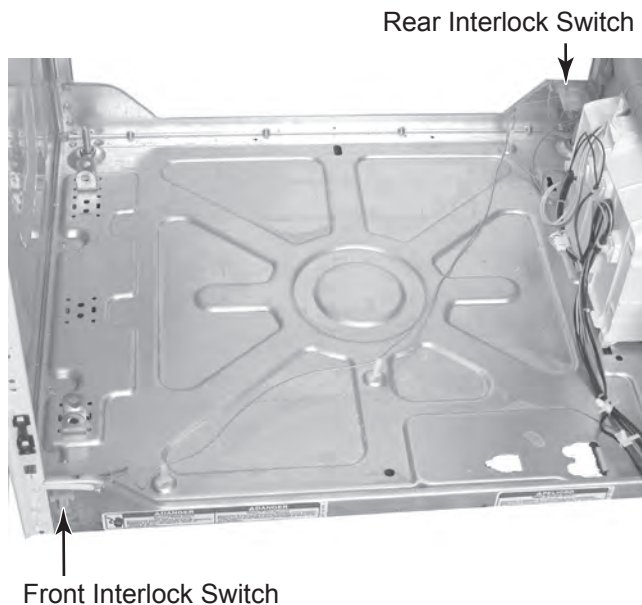

4. Press the two locking tabs in to release them, and slide the switch holder up and out of the chassis cutout.

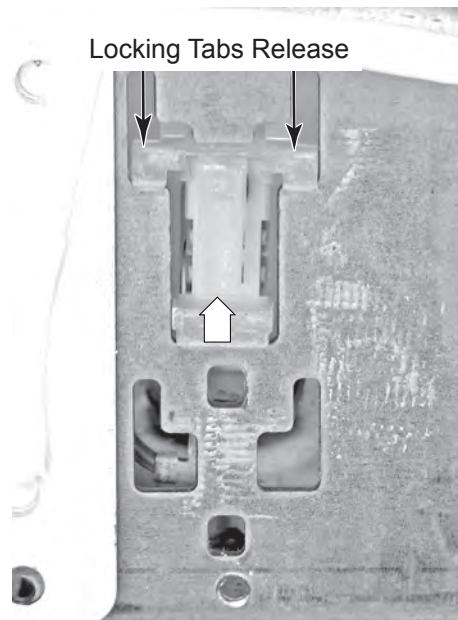

5. Disconnect the two wires from the switch terminals and unhook the wires from the clips.

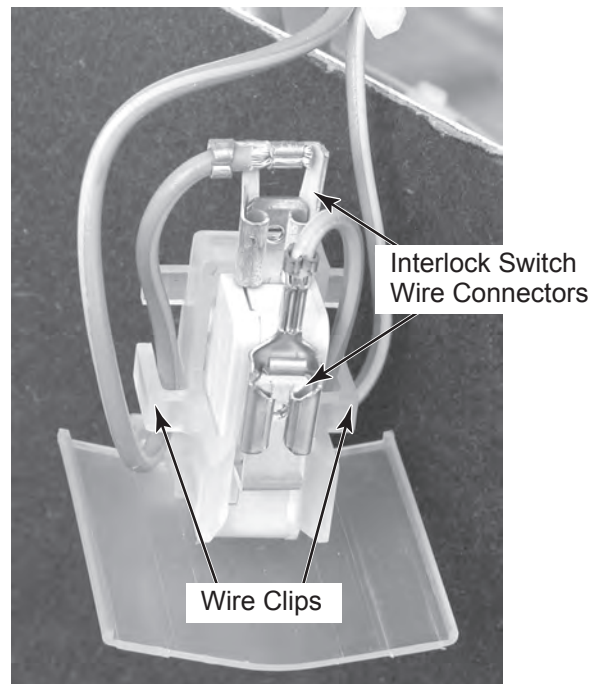

**Continued on the next page.**

6. Push out on the two locking tabs of the switch holder, rotate the switch in the direction of the arrow, and remove the switch from the holder.

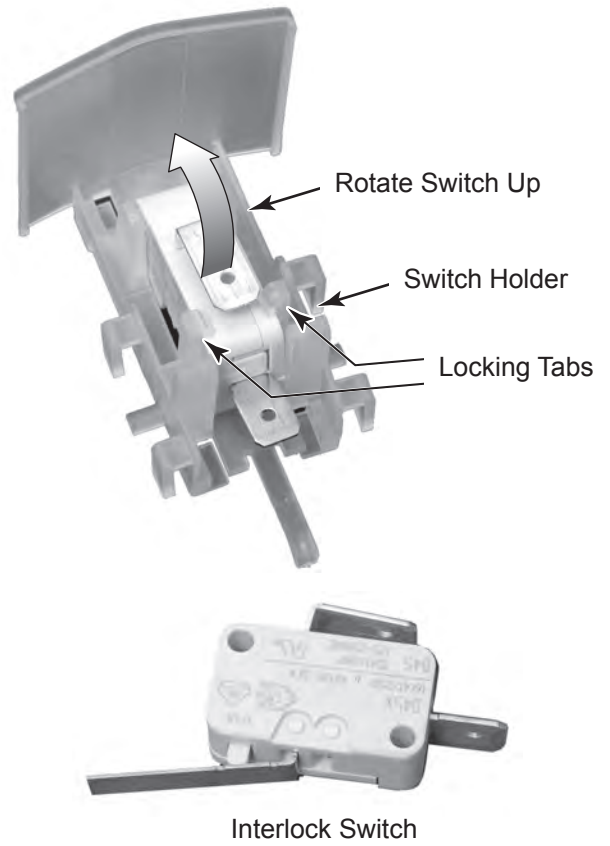

## REMOVING THE BASKET DRIVE PULLEY

### **⚠ WARNING**



#### **Electrical Shock Hazard**

**Disconnect power before servicing.**

**Replace all parts and panels before operating.**

**Failure to do so can result in death or electrical shock.**

1. Unplug washer or disconnect power.
2. Turn off the water supply to the washer.
3. Pull the washer away from the wall.
4. Remove the rear panel from the washer (see page 4-20 for the procedure).
5. Remove the drive belt from the pulley by rotating the pulley and pulling the belt off (see the top right photo).

6. Use a large screwdriver and lock the pulley, then remove the 15/16" nut from the drive pulley.

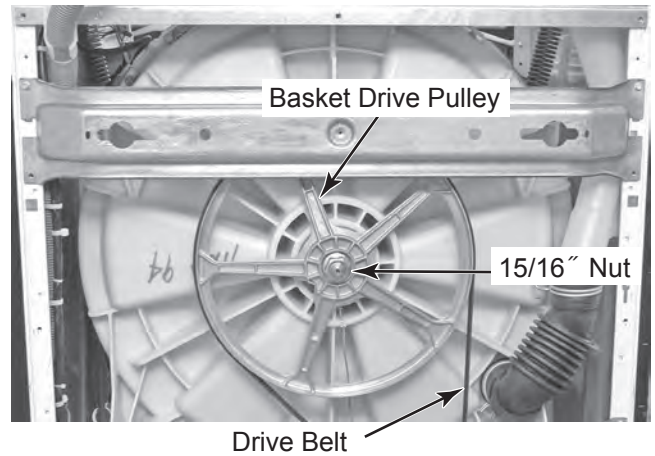

7. Pull the basket drive pulley off the basket shaft and remove it.

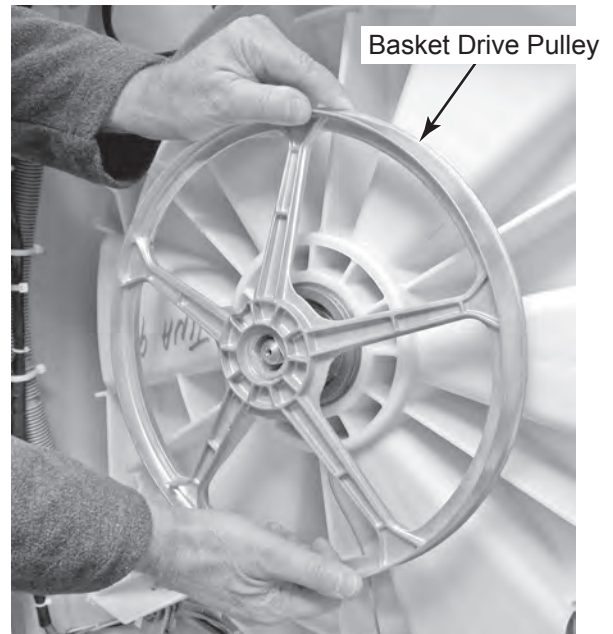



## REMOVING THE TUB & BASKET AND BAFFLE

### **⚠ WARNING**



#### **Electrical Shock Hazard**

**Disconnect power before servicing.  
Replace all parts and panels before  
operating.**

**Failure to do so can result in death or  
electrical shock.**

1. Unplug washer or disconnect power.
2. Turn off the water supply to the washer.
3. Pull the washer away from the wall.
4. Remove the detergent dispenser assembly (see pages 4-10 through 4-12 for the procedure).
5. Loosen the clamp and remove the main water feed tube from the detergent dispenser.
6. Pull the free end of the main water feed tube from the tub opening.

**REASSEMBLY NOTE:** When you reconnect the water feed tube, align the arrow on the tube with the line on the detergent dispenser.

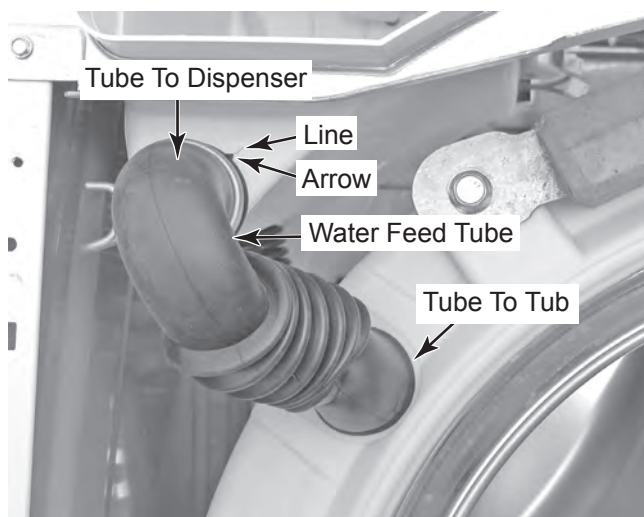

7. Remove the eight hex-head screws from the front frame and remove the frame.

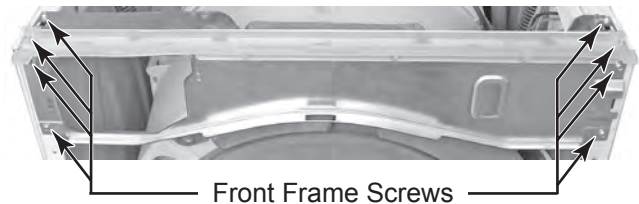

8. Remove the 1/2" bolts (3 each) from the front top and bottom tub weights, and remove the weights from the tub.

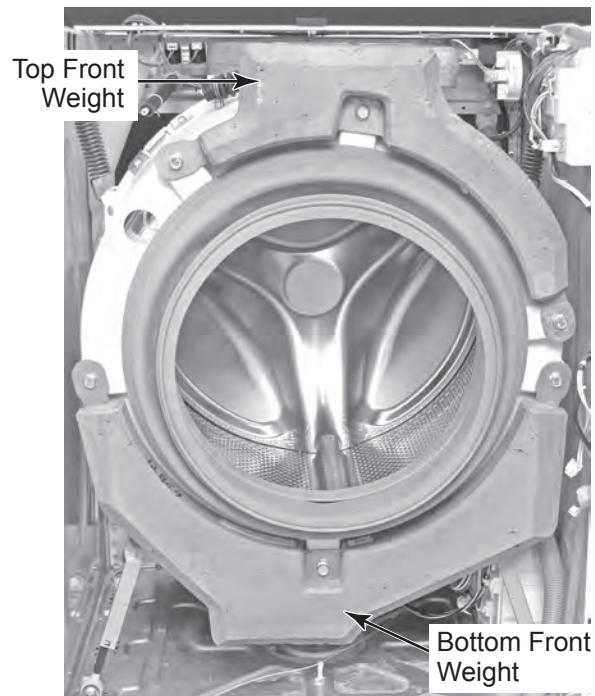

9. Rotate the support out of the way, and remove the three 1/2" bolts from the top rear weight, then remove the weight from the washer.

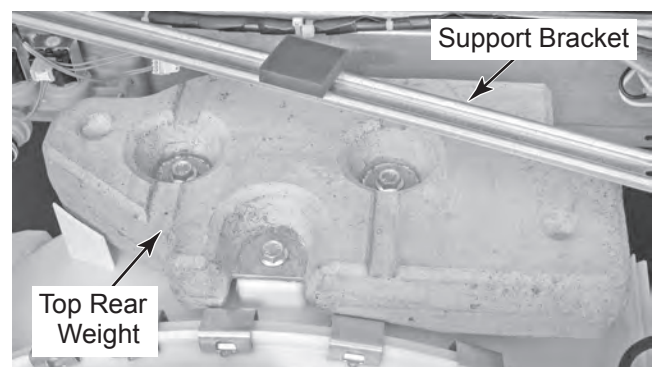

10. Remove the bellows from the tub (see pages 4-14 through 4-16 for the procedure).
11. Using a shallow pan to catch the water, unscrew the filter from the drain pump, and drain the water from the pump.

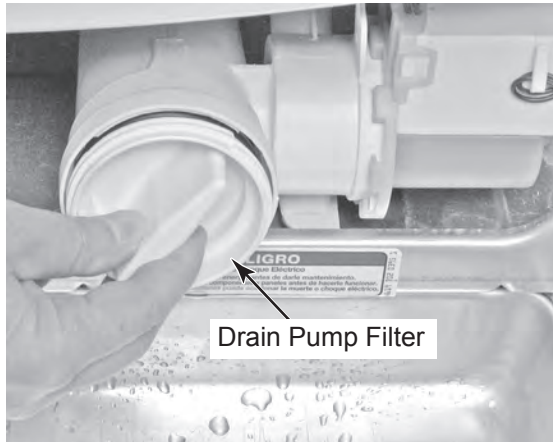

12. Loosen the clamp and remove the pump-to-tub hose from the drain pump.

**REASSEMBLY NOTE:** When you reconnect the hose, align the tab with the arrow on the drain pump.

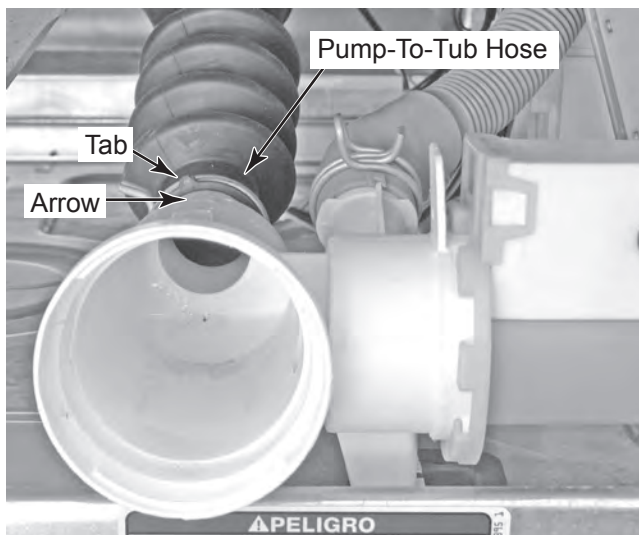

13. Remove the rear panel (see page 4-20 for the procedure).

14. Loosen the clamp and remove the vent tube-to-tub end.

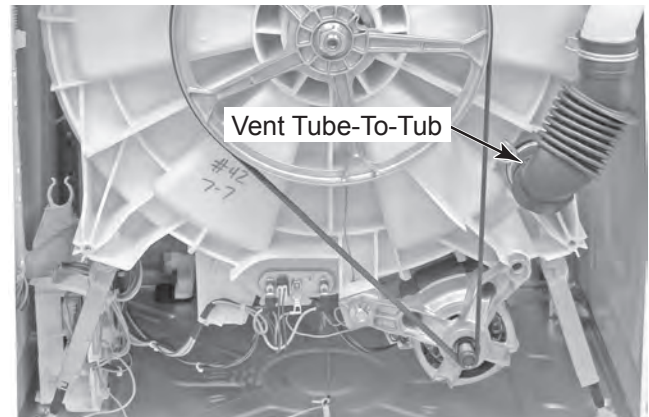

15. Remove the basket drive pulley from the basket shaft (see page 4-27 for the procedure).
16. Remove the T-20 Torx screw from the ground wire that is connected to the bearing hub, and pull the wire out of the tub holes.

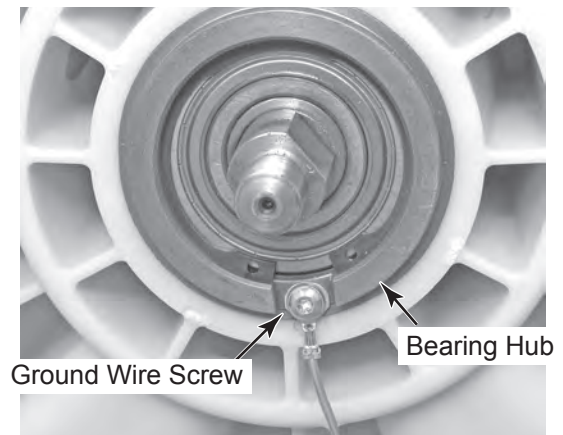

17. Disconnect the pressure hose from the pressure switch.

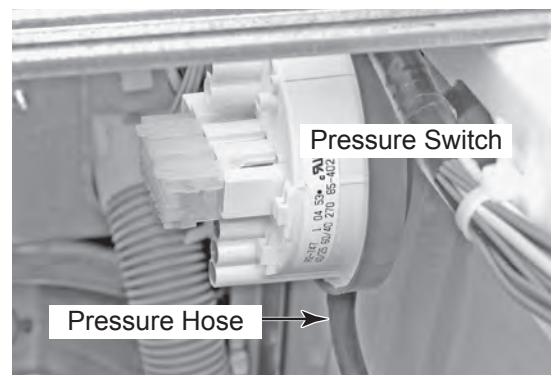

**Continued on the next page.**



18. Remove the drive motor from the tub (see page 4-23 for the procedure).
19. Remove the temperature sensor and heater from the tub (see page 4-22 for the procedure).
20. Remove the four motor control unit wiring standoffs from the tub. Squeeze in on the standoff tabs to release the standoffs.

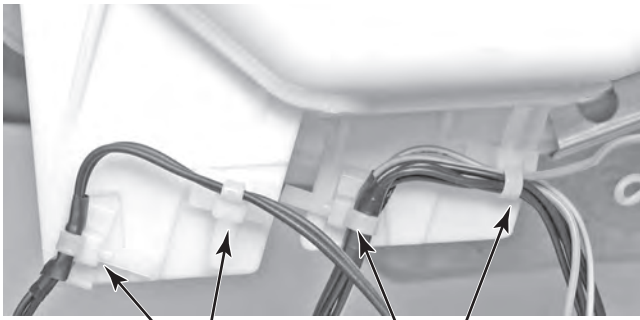

Motor Control Unit Wiring Standoffs

21. Remove the four shock absorbers from the tub. To remove a shock absorber:
  - a) Remove the 11/16" (17 mm) mounting bolt and nut from the base.



11/16" (17 mm)  
Bolt & Nut

- b) Using a pair of pliers, turn the top of the shock absorber 90° so that the locking tabs align with the slots in the tub, and remove the shock absorber.

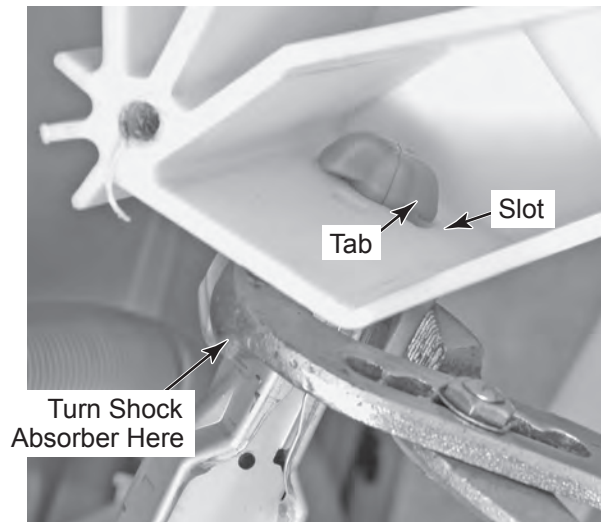

**REASSEMBLY NOTE:** When you reinstall the shock absorbers in the base mounting brackets, tighten the nut until it contacts the bracket, then turn the nut an additional 1/4-turn.

22. Remove the end of the vent tube from the tub.
23. **To remove the tub and basket:**
  - a) Lift the tub and basket assembly and unhook the two suspension springs, then remove the assembly from the washer, and place it front-side down on a padded surface.

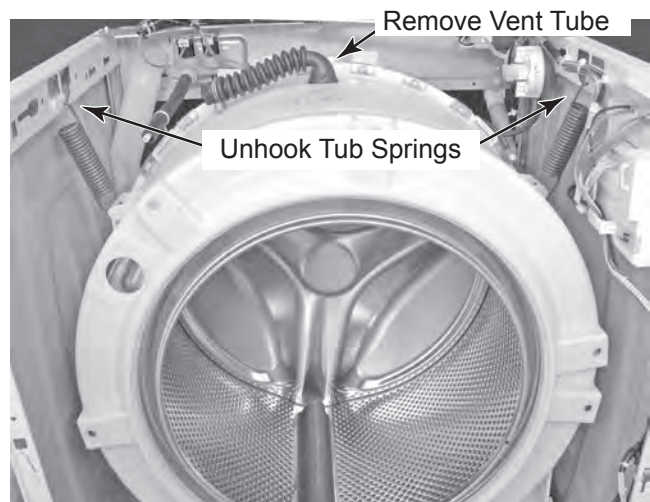

b) Remove the flat nuts from the tub.

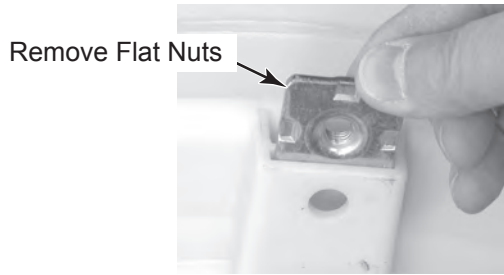

c) Mark the edges of the tub clamps with a pencil to make it easier to reinstall later.

d) Use a large flat-blade screwdriver and pry off the tub clamps.

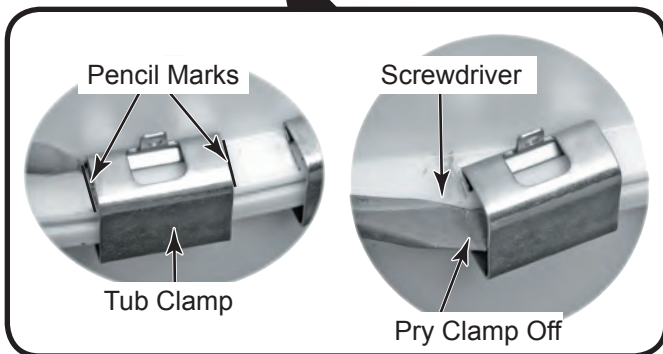
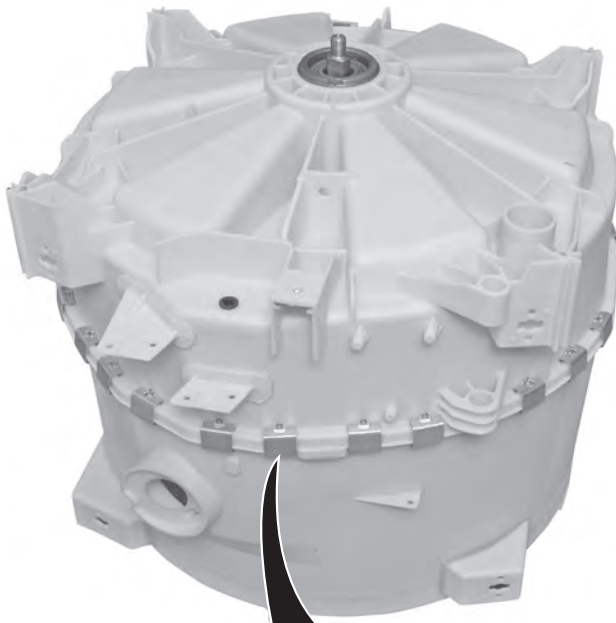

e) Use a large flat-blade screwdriver and pry the tub halves apart, then lift the rear half of the tub off the front half (see the top right photo).

f) Lift the basket from the front half of the tub.

24. To replace the tub gasket, pry the gasket out of the slot, and remove it. **NOTE:** The tub gasket hub is molded into the rear half of the tub. If it is worn and needs to be replaced, replace the rear half of the tub.

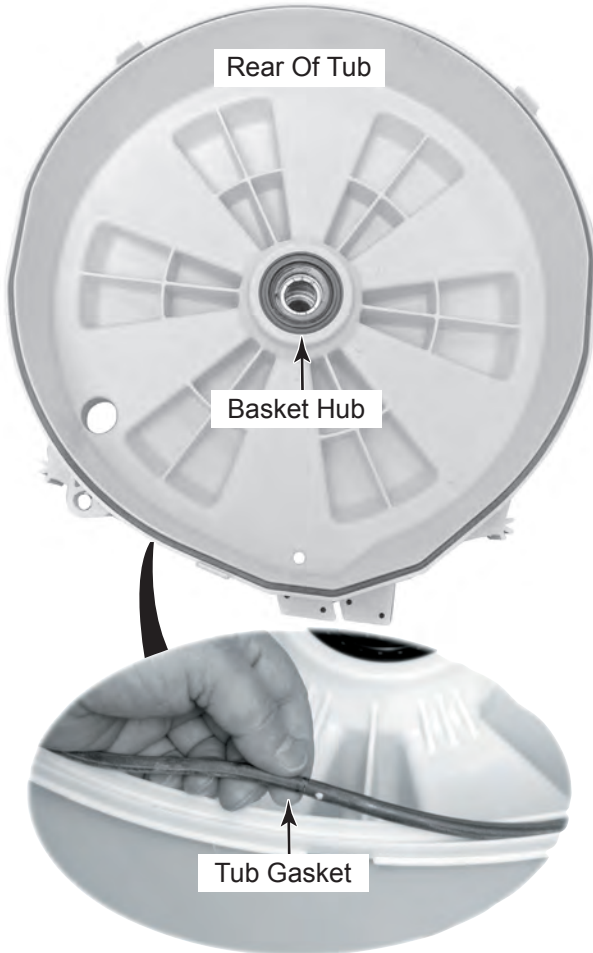

25. To replace a basket baffle (see the right column photos):

- Position the basket with the baffle to be removed on top.
- Using a flat-blade screwdriver, pry up on the two basket locking tabs so they are above the baffle stops.
- Reach inside the basket, and slide the baffle toward the opening until the tabs are aligned with the large basket slots, then lower the baffle, and remove it from the basket.

**NOTE:** When you reinstall the baffle, make sure that you press the two basket locking tabs down below the baffle stops.

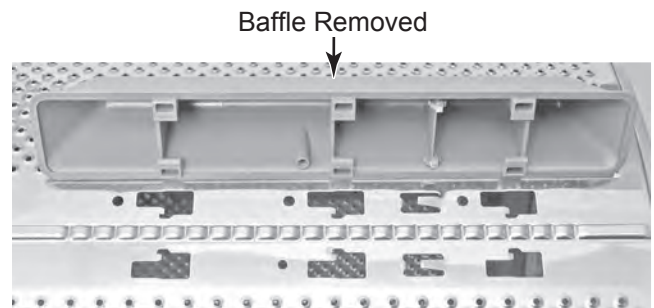
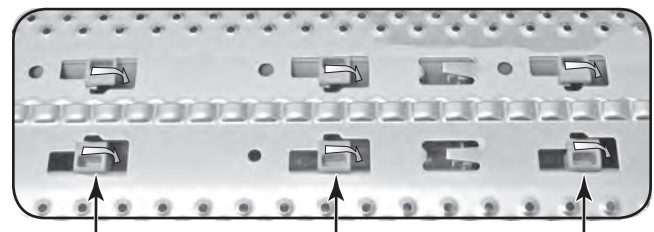
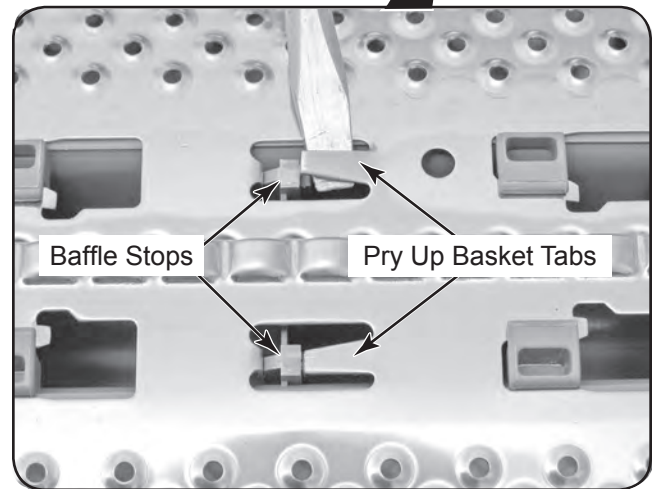
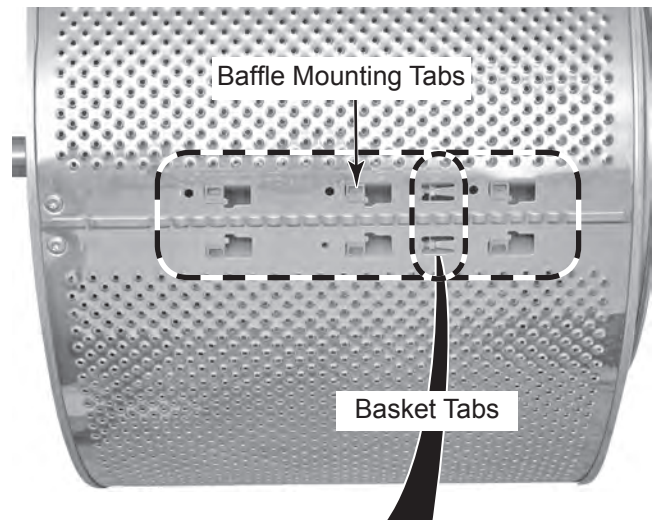



# COMPONENT TESTING

Before testing any of the components, perform the following checks:

- Control failure can be the result of corrosion on connectors. Therefore, disconnecting and reconnecting wires will be necessary throughout test procedures.
- All tests/checks should be made with a VOM or DVM having a sensitivity of 20,000 ohms-per-volt DC, or greater.
- Check all connections before replacing components, looking for broken or loose wires, failed terminals, or wires not pressed into connectors far enough.
- Resistance checks must be made with power cord unplugged from outlet, and with wiring harness or connectors disconnected.
- Unless stated otherwise, make all resistance checks by disconnecting the component connector at the Central Control Unit (CCU).



## ⚠ WARNING

### Electrical Shock Hazard

**Disconnect power before accessing.**  
**Replace all parts and panels before operating.**  
**Failure to do so can result in death or electrical shock.**

## INLET VALVE SOLENOIDS

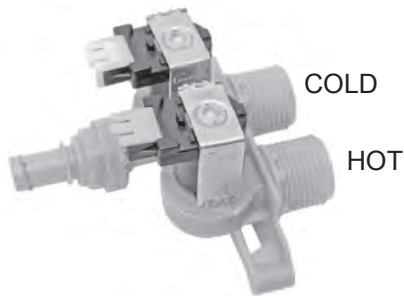

Refer to page 4-6 for the procedure for accessing the inlet valve.

To check the inlet valve solenoids at the component terminals, perform the following steps.

1. Unplug washer or disconnect power.
2. Disconnect the solenoid connectors from the inlet valve terminals.
3. Set the ohmmeter to the R X 100 scale.
4. Touch the ohmmeter test leads to the cold and hot water connector terminals. The meter should indicate between 750 and 850  $\Omega$ .

To check the inlet valve solenoids at the CCU, perform the following steps.

1. Unplug washer or disconnect power.
2. Disconnect the inlet valve solenoid connector **VCH7** (see page 4-5) from the CCU.
3. Set the ohmmeter to the R X 100 scale.
4. Touch the ohmmeter test leads to the following connector pins. The meter should indicate between 750 and 850  $\Omega$ .
  - Pins 1 & 3 (cold)
  - Pins 5 & 7 (hot)

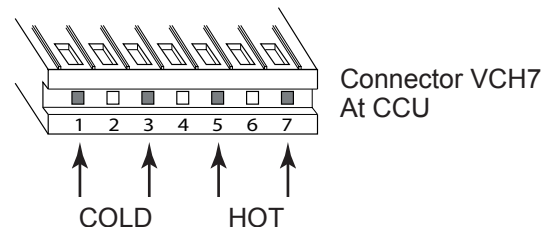



## ⚠ WARNING

### Electrical Shock Hazard

Disconnect power before accessing.  
Replace all parts and panels before operating.  
Failure to do so can result in death or electrical shock.

## PRESSURE SWITCH

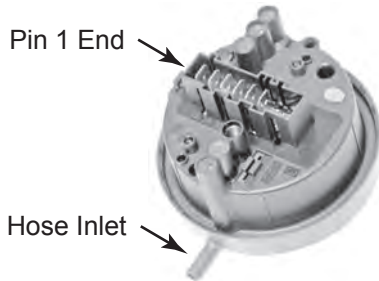

Refer to page 4-7 for the procedure for accessing the pressure switch.

To check the pressure switch at the component terminals, perform the following steps.

1. Unplug washer or disconnect power.
2. Disconnect the wire connector and hose from the pressure switch.
3. Set the ohmmeter to the R X 1 scale.
4. Touch the ohmmeter test leads to the pressure switch connector pins shown below. Blow into the hose inlet of the pressure switch to activate the diaphragm. The meter should indicate 0  $\Omega$  for each measurement while the diaphragm is activated.

<u>Water Level Setting</u>	<u>Test Points</u>
Empty	Pins 4 and 6
Suds Detect	Pins 1 and 2
L1	Pins 4 and 5
Overflow	Pins 3 and 4

To check the pressure switch at the CCU, perform the following steps.

1. Unplug washer or disconnect power.
2. Disconnect pressure switch connector **PR6** (see page 4-5) from the CCU.
3. Set the ohmmeter to the R X 1 scale.
4. Touch the ohmmeter test leads to connector pins 1 and 2. The meter should indicate 0  $\Omega$ .

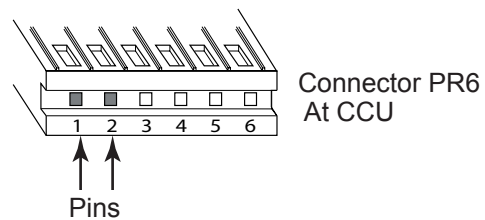





## ⚠ WARNING

### Electrical Shock Hazard

Disconnect power before accessing.  
Replace all parts and panels before operating.  
Failure to do so can result in death or electrical shock.

## LINE FILTER

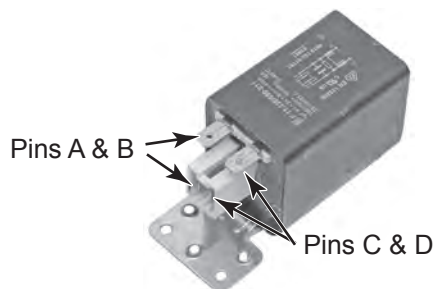

Refer to page 4-8 for the procedure for accessing the line filter.

To check the line filter at the component terminals, perform the following steps.

1. Unplug washer or disconnect power.
2. Disconnect the wire connectors from the line filter.
3. Set the ohmmeter to the R X 1 scale.
4. Touch the ohmmeter test leads to the following connector pins (shown above). The meter should indicate 0  $\Omega$  for each measurement.

Pins A and B  
Pins C and D

To check the line filter at the CCU, perform the following steps.

1. Unplug washer or disconnect power.
2. Disconnect the line filter connector **IF2** (see page 4-5) from the CCU.
3. Set the ohmmeter to the R X 1 scale.
4. Touch the ohmmeter test leads to connector pins 1 and 2. The meter should indicate 0  $\Omega$ .

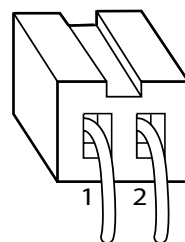

Connector IF2  
At CCU



## ⚠ WARNING

### Electrical Shock Hazard

Disconnect power before accessing.  
Replace all parts and panels before operating.  
Failure to do so can result in death or electrical shock.

## DETERGENT DISPENSER MOTOR & SWITCH

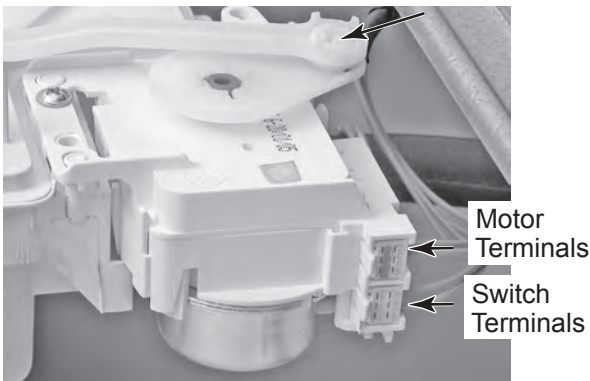

Refer to page 4-13 for the procedure for accessing the detergent dispenser motor.

To check the motor at the component terminals, perform the following steps.

1. Unplug washer or disconnect power.
2. Disconnect the two wire connectors from the motor and switch terminals.
3. Set the ohmmeter to the R X 100 scale.
4. Touch the ohmmeter test leads to the following connector terminals (shown above). The meter should indicate as follows:

Motor Terminals = 1400  $\Omega$

Switch Terminals = 0  $\Omega$

To check the motor at the CCU, perform the following steps.

1. Unplug washer or disconnect power.
2. Disconnect the detergent dispenser connector **DI6** (see page 4-5) from the CCU.
3. Set the ohmmeter to the R X 1 scale.
4. Touch the ohmmeter test leads to the following connector pins. The meter should indicate as follows:

Motor Pins 1 & 3 = 1400  $\Omega$

Switch Pins 5 & 6 = 0  $\Omega$

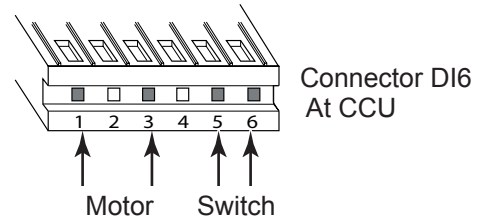



## ⚠ WARNING

### Electrical Shock Hazard

Disconnect power before accessing.

Replace all parts and panels before operating.

Failure to do so can result in death or electrical shock.

## DOOR SWITCH



Refer to page 4-14 for the procedure for accessing the door switch.

To check the door switch at the CCU, perform the following steps.

1. Unplug washer or disconnect power.
2. Disconnect the door lock/unlock solenoids connector **DL3** (see page 4-5) from the CCU.

3. Set the ohmmeter to the R X 1 scale.
4. **To test the door lock/unlock solenoids**, touch the ohmmeter test leads to the indicated pins on connector **DL3**. The meter should indicate as follows:  
Door Unlock Solenoid - Pins 2 & 3 = 60  $\Omega$   
Door Lock Solenoid - Pins 1 & 3 = 60  $\Omega$
5. Disconnect the door switch connector **DS2** (see page 4-5) from the CCU.
6. **To test the door switch**, touch the ohmmeter test leads to pins 3 and 1 at **DS2**. The meter should indicate as follows:  
Door Closed = 0  $\Omega$   
Door Open = infinite

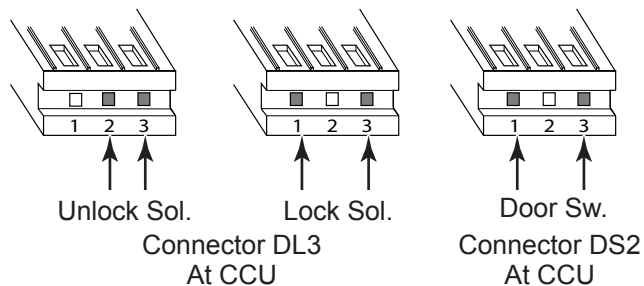



## ⚠ WARNING

### Electrical Shock Hazard

Disconnect power before accessing.  
Replace all parts and panels before operating.  
Failure to do so can result in death or electrical shock.

## DRAIN PUMP

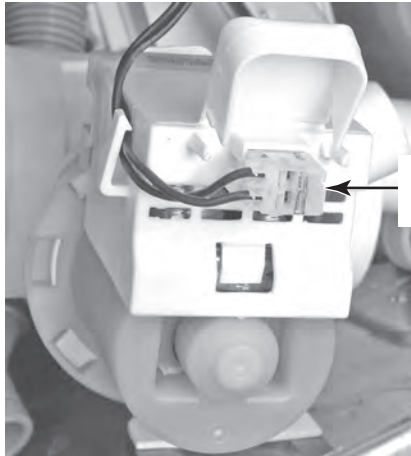

Drain Pump  
Connector

Refer to page 4-17 for the procedure for accessing the drain pump.

To check the drain pump at the component terminals, perform the following steps.

1. Unplug washer or disconnect power.
2. Disconnect the wire connector from the drain pump.
3. Set the ohmmeter to the R X 1 scale.
4. Touch the ohmmeter test leads to the drain pump terminals. The meter should indicate approximately 12.3  $\Omega$ .

To check the drain pump at the CCU, perform the following steps.

1. Unplug washer or disconnect power.
2. Disconnect the drain pump connector **DP2** (see page 4-5) from the CCU.
3. Set the ohmmeter to the R X 1 scale.
4. Touch the ohmmeter test leads to connector pins 1 and 2. The meter should indicate approximately 12.3  $\Omega$ .

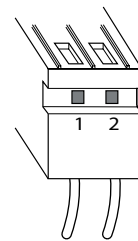

Connector DP2  
At CCU



# ⚠ WARNING

## Electrical Shock Hazard

**Disconnect power before accessing.  
Replace all parts and panels before operating.  
Failure to do so can result in death or electrical shock.**

### TEMPERATURE SENSOR & HEATER



Refer to page 4-22 for the procedure for accessing the temperature sensor & heater.

To check the temperature sensor or heater at the component terminals, perform the following steps.

1. Unplug washer or disconnect power.
2. Disconnect the wire connector from the temperature sensor or heater.
3. Set the ohmmeter to the R X 1K scale.
4. **To check the temperature sensor**, touch the ohmmeter test leads to the sensor terminals. The meter should indicate as shown in the chart below.

Temperature	Results
32°F (0°C)	35.9k Ω
86°F (30°C)	9.7k Ω
104°F (40°C)	6.6k Ω
122°F (50°C)	4.6k Ω
140°F (60°C)	3.2k Ω
158°F (70°C)	2.3k Ω
203°F (95°C)	1k Ω

5. Set the ohmmeter to the R X 1 scale.
6. **To check the heater**, touch the ohmmeter test leads to the two terminals. The meter should indicate between 10 and 15 Ω.

To check the temperature sensor at the CCU, perform the following steps.

1. Unplug washer or disconnect power.
2. Disconnect the temperature sensor connector **TH2** (see page 4-5) from the CCU.
3. Set the ohmmeter to the R X 1K scale.
4. Touch the ohmmeter test leads to connector pins 1 and 2. The meter should indicate as shown in the chart below.

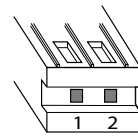

Connector TH2  
At CCU

Temperature	Results
32°F (0°C)	35.9k Ω
86°F (30°C)	9.7k Ω
104°F (40°C)	6.6k Ω
122°F (50°C)	4.6k Ω
140°F (60°C)	3.2k Ω
158°F (70°C)	2.3k Ω
203°F (95°C)	1k Ω

To check the heater at the CCU, perform the following steps.

1. Unplug washer or disconnect power.
2. Disconnect the heater connector **HE2** (see page 4-5) from the CCU.
3. Set the ohmmeter to the R X 1 scale.
4. Touch the ohmmeter test leads to connector pins 1 and 2. The meter should indicate between 10 and 15 Ω.

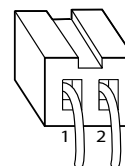

Connector HE2  
At CCU





## ⚠ WARNING

### Electrical Shock Hazard

Disconnect power before accessing.  
Replace all parts and panels before operating.  
Failure to do so can result in death or electrical shock.

## DRIVE MOTOR

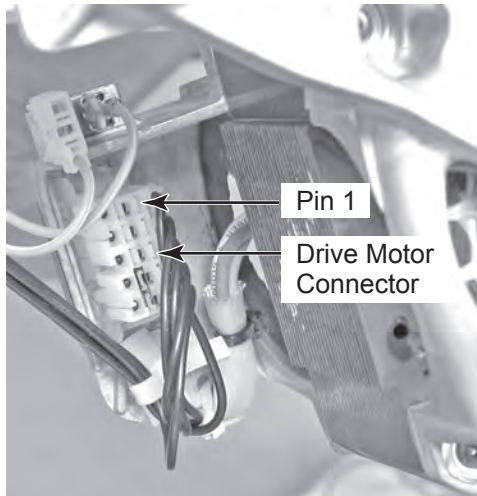

Refer to page 4-23 for the procedure for accessing the drive motor.

1. Unplug washer or disconnect power.
2. Disconnect the 5-wire connector from the drive motor.
3. Set the ohmmeter to the R X 1 scale.
4. Touch the ohmmeter test leads to the following motor pins. For each measurement, the meter should indicate approximately 6  $\Omega$ :

Pins 1 and 2  
Pins 2 and 3  
Pins 1 and 3

## INTERLOCK SWITCH

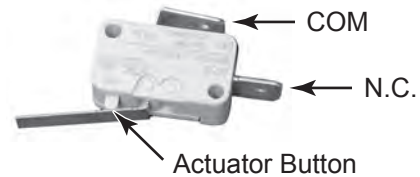

Refer to page 4-25 for the procedure for accessing an interlock switch.

1. Unplug washer or disconnect power.
2. Disconnect the wire connectors from either of the interlock switch terminals.
3. Set the ohmmeter to the R X 1 scale.
4. Touch the ohmmeter test leads to the two interlock switch terminals. The meter should indicate an open circuit with the actuator button pushed in, and a closed circuit (0  $\Omega$ ) with the actuator button out.

# DIAGNOSTICS & TROUBLESHOOTING

## DIAGNOSTICS

### DIAGNOSTIC GUIDE

Before servicing, check the following:

- Make sure there is power at the wall outlet.
- Has a household fuse blown or circuit breaker tripped? Time delay fuse?
- Are both hot and cold water faucets open and water supply hoses unobstructed?
- All tests/checks should be made with a VOM or DVM having a sensitivity of 20,000 ohms per volt DC or greater.
- Check all connections before replacing components. Look for broken or loose wires, failed terminals, or wires not pressed into connections far enough.
- A potential cause of a control not functioning is corrosion on connections. Observe connections and check for continuity with an ohmmeter.
- Connectors: Look at top of connector. Check for broken or loose wires. Check for wires not pressed into connector far enough to engage metal barbs.
- Resistance checks must be made with power cord unplugged from outlet, and with wiring harness or connectors disconnected.

# FAILURE/ERROR DISPLAY CODES

Communication of failure codes will be dis-

played on the washer console by all cycle lights flashing and standing status lights.

DISPLAY	EXPLANATION AND RECOMMENDED PROCEDURE
<b>F01</b> Reference Status LEDs chart, page 6-4	<b>EEPROM ERROR</b> A communication error between the Central Control Unit (CCU) and the EEPROM onboard the CCU occurred. <b>Possible Causes/Procedure</b> <ul style="list-style-type: none"> <li>■ A power glitch may cause this error.                             <ul style="list-style-type: none"> <li>- Unplug washer or disconnect power for two minutes.</li> <li>- Verify CCU operation by running a Diagnostic Test or any cycle.</li> </ul> </li> </ul>
	<b>PUMP DRIVE ERROR</b> The pump driver fails to activate. <b>Possible Causes/Procedure</b> <ul style="list-style-type: none"> <li>■ Replace CCU board.</li> </ul>
	<b>MAIN RELAYS ERROR</b> One of the main relays is not working properly. <b>Possible Causes/Procedure</b> <ul style="list-style-type: none"> <li>■ The relay might be soldered or always open.                             <ul style="list-style-type: none"> <li>- Replace CCU board.</li> </ul> </li> </ul>
	<b>MOTOR CONTROL UNIT ERROR</b> The Motor Control Unit has internal failure; repeating under or over voltage, or over current conditions. If failure occurs during high-speed spin the door unlocks after 3 minutes. <b>Possible Causes/Procedure</b> <ol style="list-style-type: none"> <li>1. Unplug washer or disconnect power.</li> <li>2. Check wire harness connections between the drive motor and the Motor Control Unit (MCU), and between the MCU and the Central Control Unit (CCU). Check the motor and do a continuity test.</li> <li>3. Plug in washer or reconnect power.</li> <li>4. Check the MCU by looking for operations of the drive motor.</li> <li>5. Check the drive motor for powered rotations.</li> <li>6. Replace MCU board.</li> </ol>
	<b>NO WATER DETECTED ENTERING MACHINE OR PRESSURE SWITCH TRIP NOT DETECTED.</b> The pressure switch is not tripped after 6 minutes. <b>Possible Causes/Procedure</b> <ul style="list-style-type: none"> <li>■ If there is no water in the unit:                             <ul style="list-style-type: none"> <li>- Make sure that both valves at the water source(s) are turned on all the way.</li> <li>- Check for plugged or kinked inlet hoses or plugged screens in the inlet valves.</li> <li>- Verify inlet valve operation.</li> </ul> </li> <li>■ If there is water in the unit:                             <ul style="list-style-type: none"> <li>- Verify drain pump operation.</li> <li>- Verify that the pressure switch hose is in good condition and properly connected to tub and pressure switch.</li> </ul> </li> </ul> <ol style="list-style-type: none"> <li>1. Verify there is not a siphon problem.</li> <li>2. Press PAUSE/CANCEL twice to clear the display. The machine will drain for 3 minutes before unlocking the door.</li> <li>3. Unplug washer or disconnect power.</li> <li>4. Verify wire harness connections to inlet valves, pressure switch, drain pump and Central Control Unit (CCU).</li> <li>5. Check all hoses for possible leaks.</li> <li>6. Plug in washer or reconnect power</li> <li>7. Verify pressure switch operation.</li> <li>8. Verify CCU operation by running a Diagnostic Test or any cycle.</li> </ol>

DISPLAY	EXPLANATION AND RECOMMENDED PROCEDURE
<b>F21</b> Reference Status LEDs chart, page 6-4	<b>LONG DRAIN</b> If the drain time exceeds 8 minutes the water valves turn off. <b>NOTES:</b> <ul style="list-style-type: none"> <li>■ After 4 minutes the "Sd" error will be displayed, then 4 minutes later the "F/21" error code will be displayed.</li> <li>■ Press PAUSE/CANCEL two times to clear the display.</li> </ul>
	<b>Possible Causes/Procedure</b> <ol style="list-style-type: none"> <li>1. Check the drain hose and make sure it is not plugged or kinked.</li> <li>2. Unplug washer or disconnect power.</li> <li>3. Check the electrical connections at the pump and make sure the pump is running.</li> <li>4. Check the drain pump filter for foreign objects.</li> <li>5. Plug in washer or reconnect power.</li> <li>6. If the above does not correct the problem, go to step 7.</li> <li>7. Unplug washer or disconnect power.</li> <li>8. Replace the pump.</li> </ol>
<b>F22</b> Reference Status LEDs chart, page 6-4	<b>DOOR LOCK ERROR</b> After 6 failed attempts to lock the door. <b>Possible Causes/Procedure</b> <ul style="list-style-type: none"> <li>■ Door lock mechanism is broken or removed from door.</li> <li>■ Door switch/lock unit failure.                             <ol style="list-style-type: none"> <li>1. Unplug washer or disconnect power.</li> <li>2. Check door switch/lock unit.</li> <li>3. Check the wire harness connections to the door switch/lock unit and Central Control Unit (CCU).</li> </ol> </li> </ul>
	<b>HEATER FAILURE</b> If the temperature increase during the first 40 minutes is less than 86°F (30°C). <b>Possible Causes/Procedure</b> <ol style="list-style-type: none"> <li>1. Unplug washer or disconnect power.</li> <li>2. Check connection to water heater.</li> <li>3. Check resistance of heating element, if present on this model. (abnormal = infinity)</li> <li>4. Check the water temperature sensor and connection to it. Refer to the Water Temperature Sensor section.</li> </ol>
<b>F23</b> Reference Status LEDs chart, page 6-4	<b>WATER TEMPERATURE SENSOR ERROR</b> If the water temperature sensor (NTC) value is out of range (23°F to 217°F [-5°C to 103°C]) during the water-heating step of the WASH cycle. <b>NOTE:</b> To find correct Ohm reading refer to the Water Temperature Sensor section. <b>Possible Causes/Procedure</b> <ol style="list-style-type: none"> <li>1. Unplug washer or disconnect power.</li> <li>2. Check the water temperature sensor and connection to it.</li> <li>3. Check resistance of heating element, if present on this model. (abnormal = infinity)</li> <li>4. Refer to the Water Temperature Sensor section.</li> </ol>
	<b>HEATER FAILURE</b> If the temperature increase during the first 40 minutes is less than 86°F (30°C). <b>Possible Causes/Procedure</b> <ol style="list-style-type: none"> <li>1. Unplug washer or disconnect power.</li> <li>2. Check connection to water heater.</li> <li>3. Check resistance of heating element, if present on this model. (abnormal = infinity)</li> <li>4. Check the water temperature sensor and connection to it. Refer to the Water Temperature Sensor section.</li> </ol>

DISPLAY	EXPLANATION AND RECOMMENDED PROCEDURE
<b>F 25</b> Reference Status LEDs chart, page 6-4	<p><b>DRIVE MOTOR TACHOMETER ERROR</b></p> <p>If the control is unable to properly detect motor speed, the machine shuts down. If a failure occurs during high-speed spin, the door unlocks after 3 minutes.</p> <p><b>Possible Causes/Procedure</b></p> <ol style="list-style-type: none"> <li>1. Verify the shipping system including shipping bolts, spacers and cables are removed.</li> <li>2. Unplug washer or disconnect power.</li> <li>3. Check wire harness connections between the drive motor and the Motor Control Unit (MCU), and between the MCU and the Central Control Unit (CCU).</li> <li>4. Plug in washer or reconnect power.</li> <li>5. Check the MCU by looking for operations of the drive motor.</li> <li>6. Check the drive motor for powered rotations.</li> </ol>
<b>F 26</b> Reference Status LEDs chart, page 6-4	<p><b>DOOR SWITCH ERROR</b></p> <p>If the door has not been opened for 3 consecutive cycles or the door switch is open while the door is locked for more than 5 seconds.</p> <p><b>Possible Causes/Procedure</b></p> <ul style="list-style-type: none"> <li>■ Door not opened during 3 consecutive cycles. <ol style="list-style-type: none"> <li>1. Open and close the door.</li> <li>2. Verify CCU operation by running a Diagnostic Test or any cycle.</li> </ol> </li> <li>■ Door switch open while door is locked. <ol style="list-style-type: none"> <li>1. Push the door and check if it is completely closed.</li> <li>2. Verify CCU operation by running a Diagnostic Test or any cycle.</li> </ol> </li> </ul>
<b>F 27</b> Reference Status LEDs chart, page 6-4	<p><b>OVERFLOW CONDITION</b></p> <p>If the overflow contact on the pressure switch is closed for more than 60 seconds, an Overflow Condition occurs. In an overflow condition, the door remains locked and the drain pump runs constantly, even if PAUSE/CANCEL is pressed twice and the display is cleared. Turn off hot and cold water faucets and unplug the unit before servicing.</p> <p><b>Possible Causes/Procedure</b></p> <ol style="list-style-type: none"> <li>1. Check the drain hose and make sure it is not plugged or kinked.</li> <li>2. Unplug washer or disconnect power.</li> <li>3. Check wire harness connections to the drain pump, pressure switch, water inlet valve, and Central Control Unit (CCU).</li> <li>4. Check/clean drain pump filter of foreign objects.</li> <li>5. Check for drain pump failure.</li> <li>6. Check the inlet valve for proper shut off.</li> <li>7. Check the pressure switch for proper operation.</li> </ol>
<b>F 28</b> Reference Status LEDs chart, page 6-4	<p><b>SERIAL COMMUNICATION ERROR</b></p> <p>The communication between the Central Control Unit (CCU) and the Motor Control Unit (MCU) cannot be sent correctly.</p> <p><b>Possible Causes/Procedure</b></p> <ol style="list-style-type: none"> <li>1. Unplug washer or disconnect power.</li> <li>2. Check wire harness connections to the MCU, the motor, and Central Control Unit (CCU). <ul style="list-style-type: none"> <li>– Check connections of the CCU board within the housing.</li> <li>– Make sure all grounding switches are engaged.</li> </ul> </li> <li>3. Check the drive system for any worn or failed components.</li> <li>4. Plug in washer or reconnect power.</li> <li>5. Verify CCU operation by running a Diagnostic Test or any cycle.</li> <li>6. Check the MCU by looking for operations of the drive motor.</li> <li>7. Check the drive motor for powered rotations.</li> <li>8. Check that the serial harness at the MCU is not mounted upside down. The wires should be to the left when facing the MCU connectors.</li> </ol>

DISPLAY	EXPLANATION AND RECOMMENDED PROCEDURE
<b>F 29</b> Reference Status LEDs chart, page 6-4	<p><b>DOOR UNLOCK ERROR</b></p> <p>If the door unlock has failed 6 times.</p> <p><b>Possible Causes/Procedure</b></p> <ul style="list-style-type: none"> <li>■ Door lock mechanism is broken.</li> <li>■ Door switch/lock unit failure. <ol style="list-style-type: none"> <li>1. Check door switch/lock unit for foreign objects.</li> <li>2. Unplug washer or disconnect power.</li> <li>3. Check wire harness connections to the door switch/lock unit and Central Control Unit (CCU).</li> </ol> </li> </ul> <p><b>NOTE:</b> The door switch/lock unit can be manually unlocked. See Manually Unlocking The Door Lock System.</p>
<b>F 30</b> Reference Status LEDs chart, page 6-4	<p><b>DISPENSER SYSTEM ERROR</b></p> <p>When the dispenser motor cannot be driven to its proper position.</p> <p><b>Possible Causes/Procedure</b></p> <ol style="list-style-type: none"> <li>1. Unplug washer or disconnect power.</li> <li>2. Check mechanical linkage from dispenser motor to the top of the dispenser.</li> <li>3. Check wire harness connections to the dispenser motor and Central Control Unit (CCU).</li> <li>4. Check dispenser motor for powered rotations.</li> </ol>
<b>F 31</b> Reference Status LEDs chart, page 6-4	<p><b>MCU FAILURE</b></p> <p>If the heat sink gets too hot, the Motor Control Unit (MCU) will stop the motor, the MCU will communicate this failure to the Central Control Unit (CCU), then the CCU will reset the MCU. If the condition continues four times, the F31 code will show.</p> <p><b>Possible Causes/Procedure</b></p> <ol style="list-style-type: none"> <li>1. Check for proper installation, verify the unit is not located near a source of heat and has proper ventilation.</li> <li>2. Unplug washer or disconnect power.</li> <li>3. Check wire harness connections to the MCU, the motor, and Central Control Unit (CCU).</li> <li>4. Check the drive system for any worn or failed components.</li> <li>5. Plug in washer or reconnect power.</li> <li>6. Check the MCU by looking for operations of the drive motor.</li> <li>7. Check the drive motor for powered rotations.</li> </ol>
<b>F 33</b> Reference Status LEDs chart, page 6-4	<p><b>PUMP DRIVE SYSTEM ERROR</b></p> <p>When the connection between pump and the Central Control Unit (CCU) is lost.</p> <p><b>Possible Causes/Procedure</b></p> <ol style="list-style-type: none"> <li>1. Unplug washer or disconnect power.</li> <li>2. Check wire harness connections to the pump and Central Control Unit (CCU).</li> <li>3. Plug in washer or reconnect power.</li> <li>4. Verify CCU operation by running a Diagnostic Test or any cycle. Refer to the Continuity tests.</li> </ol>
<b>rL</b> Reference Status LEDs chart, page 6-4	<p><b>LOAD INSIDE DRUM DURING CLEANING WASHER CYCLE</b></p> <p>If at the start of the CLEANING WASHER cycle a load is detected inside the drum.</p> <p><b>NOTE:</b> Detects by weight.</p> <p><b>Possible Causes/Procedure</b></p> <p>Remove clothes from drum and start the cycle again.</p>

DISPLAY	EXPLANATION AND RECOMMENDED PROCEDURE
<b>5d</b>	<p><b>SUDS LOCK (OVERDOSE OF DETERGENT DETECTED DURING THE WASH CYCLE)</b></p> <p>If suds are detected continuously by the pressure switch during the drain or spin phases, the washer will fill 4 liters of water and during 5 minutes the unit will rest without tumbling, the water will be drained and it will try to spin or drain again.</p> <p><b>Possible Causes/Procedure</b></p> <ul style="list-style-type: none"> <li>■ If too much detergent was used: <ul style="list-style-type: none"> <li>– Run the unit through a RINSE/SPIN cycle.</li> <li>– Run a NORMAL cycle without adding any detergent.</li> </ul> </li> <li>■ This should clear the unit of the excess detergent.</li> </ul> <ol style="list-style-type: none"> <li>1. Check the drain hose and make sure it is not plugged or kinked.</li> <li>2. Unplug washer or disconnect power.</li> <li>3. Check wire harness connections to the drain pump, pressure switch, and Central Control Unit (CCU).</li> <li>4. Check/clean drain pump filter of foreign objects.</li> <li>5. Plug in washer or reconnect power.</li> <li>6. Check drain pump.</li> <li>7. Check the pressure switch.</li> <li>8. Verify CCU operation by running a Diagnostic Test or any cycle.</li> </ol>

Some models do not have the display to show the failure codes. They use the status lights on the touchpad/LED.

Failure Codes	Status LEDs	
	Duet Sport	Duet Sport Ht
F/01	Add a Garment	Add a Garment
F/11	Add a Garment, Wash, Spin	Add a Garment, Soak/Prewash, Rinse
F/20	Rinse, Cycle Complete	Wash, Spin
F/21	Add a Garment, Rinse, Cycle Complete	Add a Garment, Wash, Spin
F/22	Wash, Rinse, Cycle Complete	Soak/Prewash, Wash, Spin
F/23	Add a Garment, Wash, Rinse, Cycle Complete	Add a Garment, Soak/Prewash, Wash, Spin
F/24	Spin, Cycle Complete	Rinse, Spin
F/25	Add a Garment, Spin, Cycle Complete	Add a Garment, Rinse, Spin,
F/26	Wash, Spin, Cycle Complete	Soak/Prewash, Rinse, Spin
F/27	Add a Garment, Wash, Spin, Cycle Complete	Add a Garment, Soak/Prewash, Rinse, Spin
F/28	Rinse, Spin, Cycle Complete	Wash, Rinse, Spin
F/29	Add a Garment, Rinse, Spin, Cycle Complete	Add a Garment, Wash, Rinse, Spin
F/30	Wash, Rinse, Spin, Cycle Complete	Soak/Prewash, Wash, Rinse, Spin
F/31	Add a Garment, Wash, Rinse, Spin, Cycle Complete	Add a Garment, Soak/Prewash, Wash, Rinse, Spin
F/33	Add a Garment	Add a Garment, Cycle Complete
rL	Wash	Soak/Prewash, Cycle Complete



## DIAGNOSTIC TEST

The complete built-in service diagnostic module contains two entry modes and three modes of operation.

### Entry modes:

- Universal mode across all products. It displays error history prior to performing any automated test.
- Quick entry and bypasses the displaying of error codes.

### Operation modes:

- Display the error states that have been recorded by the appliance.
- Run through an automated test.
- Run loads to assist in diagnosing potentially non-electrical issues.

### Starting Service History Mode & Diagnostic Test:

**NOTE:** The washer must be empty and the control must be in the OFF state before pressing the touchpad sequence to start the test.

1. Close the door.
2. Select any one key (except PAUSE/CANCEL) and follow the steps below, using the same key (remember the key):

Press/hold 4 seconds → Release for 4 seconds → Press/hold 4 seconds → Release for 4 seconds → Press/hold 4 seconds

3. Upon release, all console LED lights will turn on for 5 seconds.
4. If there are any failure codes, all cycle LED lights will flash and the appropriate Status LED's will turn on. The Estimated Time Display will display failure code (if available).

**NOTES:** This program recalls the most recent failure code first.

- Press the same key to advance to the next failure code. (If the console doesn't change then the same failure code was stored multiple times.)
- If there aren't any more failure codes all the lights on the console will turn on for 5 seconds.
- Next the washer begins the Diagnostic Test.
- To cancel out of service mode press PAUSE/CANCEL. (This exits you out of the program.)

### Starting Diagnostic Test and bypassing the Service History Mode:

Execute this procedure with an empty drum. All of the steps below must be done in sequence in order to reach the Diagnostic Test. This executes the automatic test but does not show the error history.

- Close the door.
- Push POWER.
- Select the CLEAN WASHER cycle.
- Press EXTRA RINSE four times within 5 seconds.
- Press EXTRA RINSE to advance to the next step of the test procedure.
- If the starting procedure fails, push PAUSE/CANCEL, then repeat the starting procedure.

## ERROR HISTORY DISPLAY

When the press and hold entry method is used and successfully completed:

- The control will respond by turning on all lights for 5 seconds. After 5 seconds all lights should turn off and the most recent error code is displayed.
- All of the cycle lights will flash and the error code will be displayed on the status lights.
- The next most recent error code is to be displayed.
- If there is no error code to display, or is the last one, then all lights should turn off for 0.5 seconds and then all turn on for 5 seconds. At the end of 5 seconds the lights will turn off and the control will advance to the automated test.

## HISTORY OVERVIEW TEST PROGRAM

Indication		Control Action	Actuators to be Checked
Whirlpool Duet Sport	Whirlpool Duet Sport Ht		
Rinse/Spin	Rinse/Spin	Door locks.	■ Door lock system
Clean Washer	Clean Washer	Distribution system is set to CLEAN position. Fill by cold water inlet valve (4 liters).	■ Dispenser motor ■ Dispenser contact ■ Cold water inlet valve
Delicate	Delicate/Hand Wash	Distribution system is set to MW position. Fill by hot water inlet valve to Level_wash	■ Dispenser motor ■ Dispenser contact ■ Hot Water inlet valve ■ Pressure switch: Level_wash
Quickwash	Quickwash	Drum executes reversing movement at wash speed (30 sec).	■ Motor ■ Motor Control (MCU)
Normal/Casual	Normal/Casual	Drum executes reversing movement at wash speed (30 sec).	■ Heater (if equipped) ■ Motor ■ Motor Control (MCU)
Heavy Duty	Heavy Duty	Drain pump is ON.	■ Drain pump
Whitest Whites	Whitest Whites	Drum rotates counter-clockwise and will ramp to the maximum speed.	■ Motor ■ Motor Control (MCU)

## MANUAL DIAGNOSTIC TEST

The washer must be empty and the control must be in the OFF state before pressing the touchpad sequence to start the test.

### Starting the Test Mode

- Close the door.
- Select any one key (except PAUSE/CANCEL) and follow the steps below, using the same key (remember the key):

Press/ Release Press/ Release Press/ Release Press/  
hold 4 → for 4 → hold 4 → for 4 → hold 4 → for 4 → hold 4  
sec's. sec's. sec's. sec's. sec's. sec's. sec's.,  
release

### NOTES:

- Press the same key to advance to the next failure code.
- At the end of the procedure the program will loop back to the beginning. This is a continuous loop.
- To cancel out of the Manual Test Mode press PAUSE/CANCEL.

## MANUAL OVERVIEW TEST PROGRAM

Be sure to perform the Diagnostic Tests before replacing the system components.

Exit Condition	Control Action	To be Checked
On completion only	Door locks.	■ Door lock system
On key press or if overflow level is detected	Distribution system is set to Main Wash compartment. Filling with both valves.	■ Dispenser Motor ■ Dispenser contact ■ Cold and Hot Water Inlet Valve ■ Overflow level
On key press or if overflow level is detected	Distribution system is set to Bleach compartment. Filling only by the Hot valve.	■ Dispenser Motor ■ Dispenser contact ■ Cold and Hot Water Inlet Valve ■ Overflow Level
On key press or if overflow level is detected	Distribution system is set to Fabric Softener compartment. Filling with both valves.	■ Dispenser Motor ■ Dispenser contact ■ Cold and Hot Water Inlet Valve ■ Overflow Level
On key press or if overflow level is detected	Distribution system is set to Bypass channel. Filling only by the Cold valve.  For model Duet Sport HT, the Heater is on during fill until Level_wash is activated (80 minutes max.)	■ Dispenser Motor ■ Dispenser contact ■ Cold Water Inlet Valve ■ Overflow Level ■ Heater element (if equipped)
On key press or completion	Drum executes reversing movement at wash speed (10 min).	■ Motor ■ Motor Control (MCU)
On key press or completion	Drain Pump is on (4 min).	■ Drain Pump
On completion only	Drain Pump is on (reach Level_sud plus 10 sec).	■ Drain Pump
On key press or completion	Drum rotates counter-clockwise and ramps up to maximum speed.	■ Motor ■ Motor Control (MCU)
On key press only after rpm = 0 and door is unlocked	Stop motor to 0 rpm. Door unlocks.	■ Motor ■ Motor Control (MCU) ■ Doorlock system

Be sure to perform the Diagnostic Tests before replacing the system components.

### Pump Motor Continuity Test

Pins	Results
1 to 2	Normal = approx. 12.3 $\Omega$ Abnormal = Infinity

### Motor Continuity Test

1. Unplug washer or disconnect power.
2. Disconnect the wire harness from the motor and measure the resistance of the motor. Use the following table:

Pins	Results
1 to 2	Normal = approx. 6 $\Omega$ Abnormal = Infinity
2 to 3	
1 to 3	

### Water Temperature Sensor

1. Unplug washer or disconnect power.
2. Disconnect the wire harness from the water temperature sensor and measure the resistance of the sensor. Use the following table. An abnormal condition is an open circuit.

Temperature	Results
32°F (0°C)	35.9k $\Omega$
86°F (30°C)	9.7k $\Omega$
104°F (40°C)	6.6k $\Omega$
122°F (50°C)	4.6k $\Omega$
140°F (60°C)	3.2k $\Omega$
158°F (71°C)	2.3k $\Omega$
203°F (96°C)	1k $\Omega$

### Manually Unlocking the Door Lock System

1. Unplug washer or disconnect power.
2. Remove the lower kick panel.
3. Reach up along the inside of the front and locate the bottom of the door switch/lock unit.
4. Located on the bottom of the door switch/lock unit is a teardrop shaped tab.
5. Gently pull the tab down about a 1/4" or until a click is heard.
6. The door may be opened.

### ELECTRONIC ASSEMBLIES - REMOVAL OR REPLACEMENT

**IMPORTANT:** Electrostatic (static electricity) discharge may cause damage to electronic control assemblies.

**NOTE:** Be sure to perform the Diagnostic Tests before replacing the control board.

#### To remove Central Control Unit (CCU):

1. Unplug washer or disconnect power.
2. Remove all connectors from the CCU.
3. Place two flat-blade screwdrivers under the left and right tab, on the top of the CCU and slide the CCU forward.

### **To reassemble CCU:**

1. Align the tab on top of the CCU with the notch in the cabinet. Also, align the posts on the back of the CCU with the hole in the back of the cabinet.
2. Slide the CCU back into place.
3. Reconnect wire harness.

### **To remove the touchpad/LED assembly:**

1. Unplug washer or disconnect power.
2. Disconnect touchpad/LED assembly wire harness from the CCU.
3. Remove dispenser drawer.
4. Remove left front screw that was covered by the dispenser drawer.
5. Open door. Under the center of the touchpad/LED assembly there is a notch. Insert a flat-blade screwdriver in notch to release the bottom of the touchpad/LED assembly.
6. On the right hand side behind the touchpad/LED assembly, press tab to release right side of the touchpad/LED assembly.
7. Gently pry up and release the top of the touchpad/LED assembly. This should completely release the entire touchpad/LED assembly.

### **To remove Motor Control Unit (MCU):**

1. Unplug washer or disconnect power.
2. Remove wire harness cover and disconnect the wire harness from the MCU.
3. With a flat-blade screwdriver, lift the front tab up and slide the MCU forward.

### **To remove line/interference filter:**

1. Unplug washer or disconnect power.
2. Disconnect the three connectors from the line filter and power cord.
3. Remove the two screws which secure the line filter to the top brace.

## **WASHER CARE**

### **Cleaning the door seal:**

1. Open the washer door and remove any clothing or items from the washer.
2. Inspect the gray colored seal between the door opening and the basket for stained areas. Pull back the seal to inspect all areas under the seal and to check for foreign objects.
3. If stained areas are found, wipe down these areas of the seal, using the procedure that follows:
  - a) Mix a dilute solution, using 3/4 cup (177 mL) of liquid chlorine bleach, and 1 gal. (3.8 L) of warm tap water.
  - b) Wipe the seal area with the dilute solution, using a damp cloth.
  - c) Let stand 5 minutes.
  - d) Wipe down area thoroughly with a dry cloth and let the washer interior air dry with door open.

### **IMPORTANT:**

- Wear rubber gloves when cleaning for prolonged periods.
- Refer to the bleach manufacturer's instructions for proper use.

### **Washer Maintenance Procedure**

This washer has a special cycle that uses higher water volumes in combination with liquid chlorine bleach to thoroughly clean the inside of the washer.

### **NOTES:**

- Read these instructions completely before beginning the cleaning process.
- If necessary, the cleaning cycle may be interrupted by pressing PAUSE/CANCEL. This will stop the cycle. A RINSE/SPIN cycle must then be run to thoroughly rinse the remaining bleach from the unit. Failure to do so will cause damage to the unit and clothing added to the next cycle.



**Begin procedure:**

1. Open the washer door and remove any clothing or items from the washer.
2. Be sure the door is closed.
3. Open the dispenser drawer and immediately add 2/3 cup (160 mL) of liquid chlorine bleach to the bleach compartment.

**NOTE:** Do not add any detergent to this cycle. Use of more than 2/3 cup (160 mL) of bleach will cause product damage over time.

4. Be sure dispenser drawer is closed.
5. Select the CLEAN WASHER cycle.
6. Press START.

**NOTE:** The basket will rotate, then the door will unlock, lock again, and then the cycle will continue.

- The machine will not fill, but the basket will rotate while the washer runs a short sensing cycle. This will take approximately 3 minutes.
7. The cycle will determine if clothing or other items are in the washer.
    - a) If no items are detected in the washer, it will proceed to step 8.

- b) If any items are detected in the washer, all cycle lights will flash and the WASH and CONTROLS LOCKED lights will remain lit. The door will unlock.

Press PAUSE/CANCEL to cancel the failure code. Then repeat steps 1, 2 and 6 to start the cycle again.

8. Once the cycle has begun, allow the cycle to be completed.
9. After the cycle is complete, leave the door open, slightly, to allow for better ventilation and drying of washer interior.

**Always do the following to maintain washer freshness:**

- Use only HE High Efficiency detergent.
- Leave the door slightly open after each cycle to allow for better ventilation and drying of washer interior.
- Repeat the cleaning procedure monthly, using 2/3 cup (160 mL) of liquid chlorine bleach.
- If the procedure does not sufficiently improve the machine freshness, please evaluate your installation and usage conditions for other causes.

# TROUBLESHOOTING GUIDE

PROBLEM	POSSIBLE CAUSE/TEST
	<b>NOTE:</b> Possible Cause/Tests must be performed in the sequence shown for each problem.
<b>WON'T POWER UP</b> (touchpads do not respond when pressed)	<ol style="list-style-type: none"> <li>1. Check that the unit is plugged into a working outlet and for blown fuses.</li> <li>2. Check for power going to Central Control Unit (CCU) by listening for a click in the CCU when unit is plugged in. If no click, replace CCU.</li> <li>3. Unplug washer or disconnect power.</li> <li>4. Check continuity of line cord and line filter.</li> <li>5. Check harness connections to CCU.</li> <li>6. Plug in washer or reconnect power.</li> <li>7. Check the touchpad/LED assembly by selecting different cycles and changing the modifiers and options available to confirm the touchpad/LED is responding.</li> </ol>
<b>WON'T START CYCLE</b>	<ol style="list-style-type: none"> <li>1. Open and close the door. The door has to be opened between consecutive wash cycles.</li> <li>2. Check the door switch/lock unit using the diagnostics. See Diagnostic Test.</li> <li>3. If door is locked, drain the unit.</li> <li>4. Unplug washer or disconnect power.</li> <li>5. Check the wire harness connections.</li> <li>6. Plug in washer or reconnect power.</li> <li>7. Check the touchpad/LED assembly by selecting different cycles and changing the modifiers and options available to confirm the touchpad/LED is responding.</li> </ol>
<b>WON'T SHUT OFF</b>	<ol style="list-style-type: none"> <li>1. Check for a Fault/Error Code on the display.</li> <li>2. Press PAUSE/CANCEL on the touchpad twice.</li> <li>3. Check the touchpad/LED assembly by selecting different cycles and changing the modifiers and options available to confirm the touchpad/LED is responding.</li> <li>4. Unplug washer or disconnect power.</li> <li>5. Check that the drain hose and drain pump filter are clear of foreign objects and not plugged.</li> <li>6. Plug in washer or reconnect power.</li> <li>7. Check drain pump.</li> <li>8. Verify CCU operation by running a Diagnostic Test or any cycle.</li> </ol>
<b>CONTROL WON'T ACCEPT SELECTIONS</b>	<ol style="list-style-type: none"> <li>1. Press PAUSE/CANCEL on the touchpad twice.</li> <li>2. Drain the unit, then check that the drain hose and drain pump filter are clear of foreign objects.</li> <li>3. Check the touchpad/LED assembly by selecting different cycles and changing the modifiers and options available to confirm the touchpad/LED is responding.</li> <li>4. Unplug washer or disconnect power.</li> <li>5. Check harness connections.</li> <li>6. Plug in washer or reconnect power.</li> <li>7. Verify CCU operation by running a Diagnostic Test or any cycle.</li> </ol>

PROBLEM	POSSIBLE CAUSE/TEST
	<b>NOTE:</b> Possible Cause/Tests must be performed in the sequence shown for each problem.
<b>WON'T DISPENSE</b>	<ol style="list-style-type: none"> <li>1. Verify the unit is level.</li> <li>2. Verify dispenser drawer is not clogged with detergent.</li> <li>3. Check water connections to the unit and within the unit. Check for plugged screen in water source.</li> <li>4. Check dispenser motor.</li> <li>5. Unplug washer or disconnect power.</li> <li>6. Check harness connections.</li> <li>7. Plug in washer or reconnect power.</li> <li>8. Verify CCU operation by running a Diagnostic Test or any cycle.</li> </ol>
<b>WON'T FILL</b>	<ol style="list-style-type: none"> <li>1. Check installation. Verify hot and cold water faucets are open.</li> <li>2. Check inlet valves.</li> <li>3. Unplug washer or disconnect power.</li> <li>4. Check water connections to the unit and within the unit. Make sure water supply hoses are unobstructed. Check for plugged screen.</li> <li>5. Plug in washer or reconnect power.</li> <li>6. Check operating pressure switch.</li> <li>7. Check drain pump motor.</li> <li>8. Verify CCU operation by running a Diagnostic Test or any cycle.</li> <li>9. Check under Won't Dispense problem above.</li> </ol>
<b>OVER FILLS</b>	<ol style="list-style-type: none"> <li>1. Verify the unit is level.</li> <li>2. Check pump drain system – this could indicate a failure to drain.</li> <li>3. Unplug washer or disconnect power.</li> <li>4. Check operating pressure switch.</li> <li>5. Check pressure switch hose.</li> <li>6. Plug in washer or reconnect power.</li> <li>7. Verify flowmeter operation by blowing air through the part and measuring the resistance.</li> <li>8. Verify CCU operation by running a Diagnostic Test or any cycle.</li> </ol>
<b>DRUM WON'T ROTATE</b>	<ol style="list-style-type: none"> <li>1. Check drive belt.</li> <li>2. Check drive motor.</li> <li>3. Unplug washer or disconnect power.</li> <li>4. Check wire harness connections.</li> <li>5. Plug in washer or reconnect power.</li> <li>6. Check the MCU by looking for operations of the drive motor.</li> </ol>
<b>MOTOR OVERHEATS</b>	<ol style="list-style-type: none"> <li>1. Check drive motor.</li> <li>2. Unplug washer or disconnect power.</li> <li>3. Check wire harness connections.</li> <li>4. Check drive belt.</li> <li>5. Plug in washer or reconnect power.</li> <li>6. Check the MCU by looking for operations of the drive motor.</li> </ol>

PROBLEM	POSSIBLE CAUSE/TEST
<b>WON'T DRAIN</b>	<p><b>NOTE:</b> Possible Cause/Tests must be performed in the sequence shown for each problem.</p> <ol style="list-style-type: none"> <li>1. Unplug washer or disconnect power.</li> <li>2. Check wire harness connections.</li> <li>3. Check drain pump.</li> <li>4. Check drain pump motor.</li> <li>5. Check that the drain hose and drain pump filter are clear of foreign objects.</li> <li>6. Plug in washer or reconnect power.</li> <li>7. Verify CCU operation by running a Diagnostic Test or any cycle.</li> </ol>
<b>MACHINE VIBRATES</b>	<ol style="list-style-type: none"> <li>1. Remove shipping system.</li> <li>2. Check installation.</li> <li>3. Check leveling feet.</li> </ol>
<b>INCORRECT WATER TEMPERATURE</b>	<ol style="list-style-type: none"> <li>1. Check that the inlet hoses are connected properly.</li> <li>2. Unplug washer or disconnect power.</li> <li>3. Check the water heater and wire harness connections to it.</li> <li>4. Check water temperature sensor for an abnormal condition. See the Water Temperature Sensor section .</li> <li>5. Plug in washer or reconnect power.</li> <li>6. Verify CCU operation by running a Diagnostic Test or any cycle.</li> </ol>
<b>DISPLAY FLASHING</b>	See Failure/Error Display Codes.

# WIRING DIAGRAMS WASHER

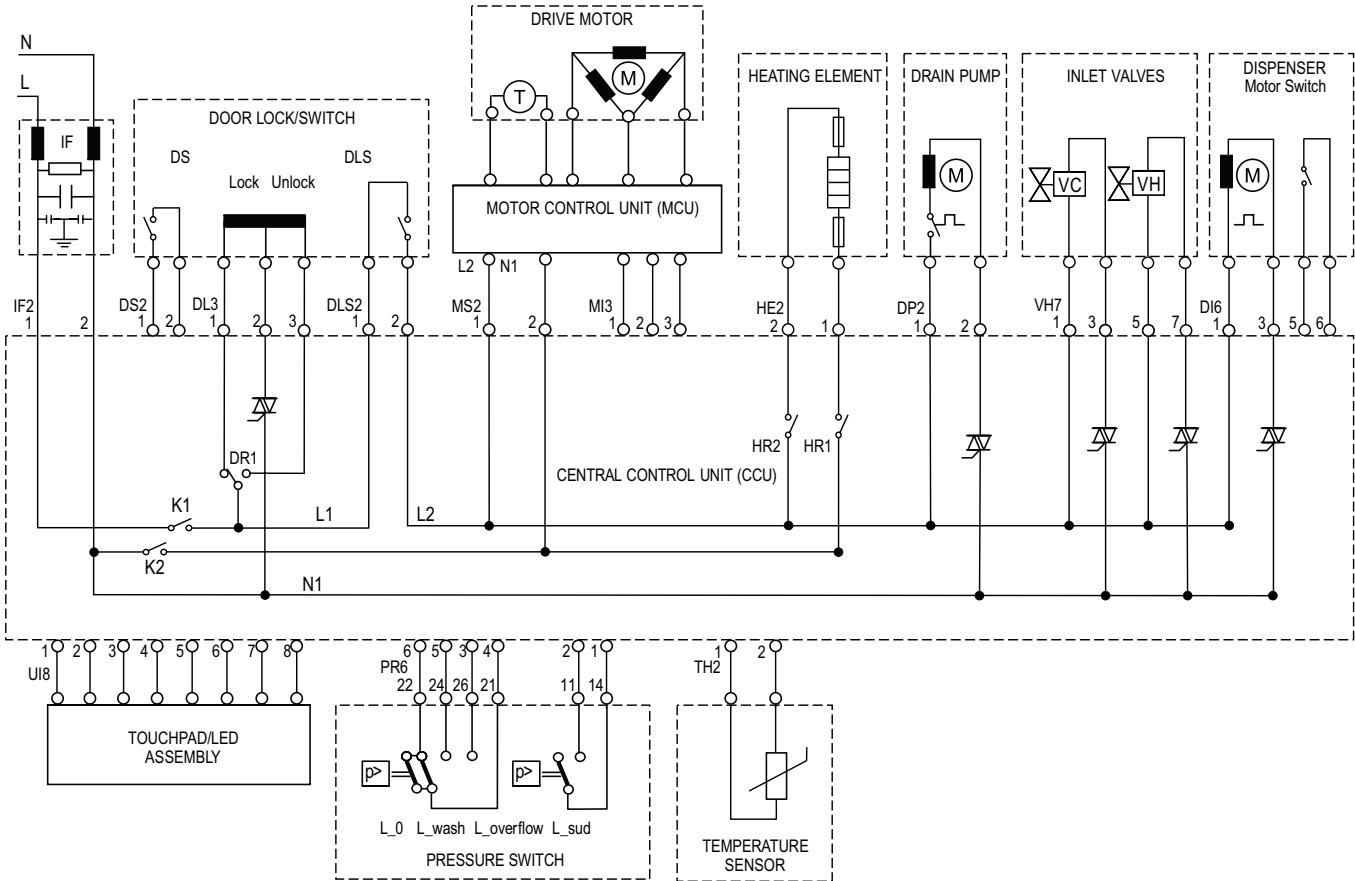

# GROUNDING SYSTEM

GROUNDING SYSTEM WITHOUT HEATER

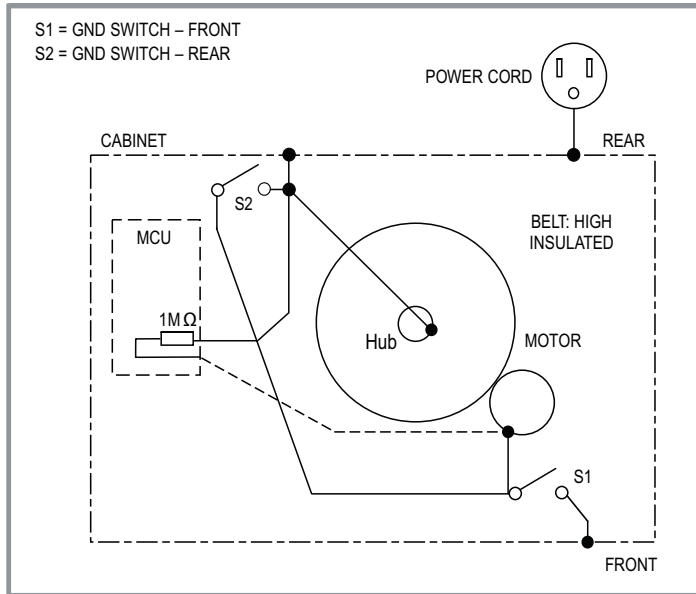

GROUNDING SYSTEM WITH HEATER

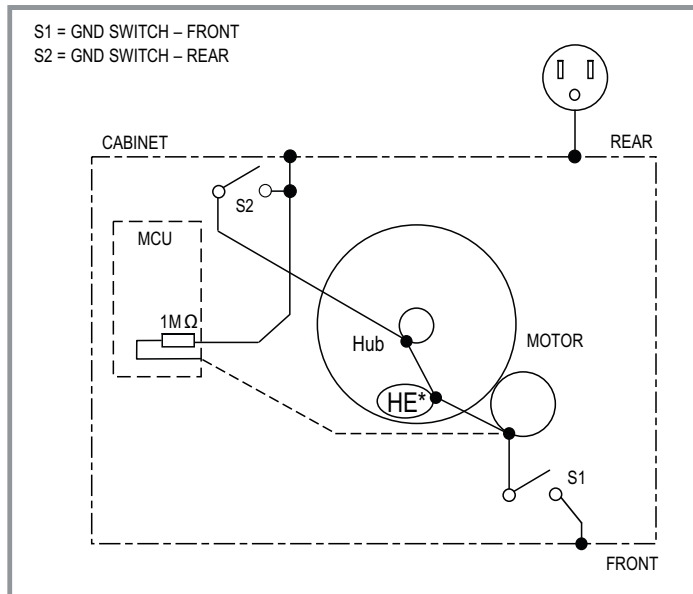

\* Heating element not present on all models



— NOTES —

— NOTES —

# **PRODUCT SPECIFICATIONS AND WARRANTY INFORMATION SOURCES**

## ***IN THE UNITED STATES:***

**FOR PRODUCT SPECIFICATIONS AND WARRANTY INFORMATION CALL:**

**FOR WHIRLPOOL PRODUCTS: 1-800-253-1301**

**FOR KITCHENAID PRODUCTS: 1-800-422-1230**

**FOR ROPER PRODUCTS: 1-800-447-6737**

**FOR TECHNICAL ASSISTANCE WHILE AT THE CUSTOMER'S HOME CALL:**

**THE TECHNICAL ASSISTANCE LINE: 1-800-253-2870**

**HAVE YOUR STORE NUMBER READY TO IDENTIFY YOU  
AS AN AUTHORIZED SERVICER**

**FOR LITERATURE ORDERS:**

**PHONE: 1-800-851-4605**

**FOR TECHNICAL INFORMATION AND SERVICE POINTERS:**

**[www.servicematters.com](http://www.servicematters.com)**

---

## ***IN CANADA:***

**FOR PRODUCT SPECIFICATIONS AND WARRANTY INFORMATION CALL:**

**1-800-461-5681**

**FOR TECHNICAL ASSISTANCE WHILE AT THE CUSTOMER'S HOME CALL:**

**THE TECHNICAL ASSISTANCE LINE: 1-800-488-4791**

**HAVE YOUR STORE NUMBER READY TO IDENTIFY YOU AS AN  
AUTHORIZED SERVICER**

