

dacor®

ELECTRONICS
Wall Ovens and Ranges
Diagnostic Test Manual

Table of Contents

ERC Quick Test.....	3
Voltage Check Points	4
Diagnostics	
No Clock Display.....	5
No Bake.....	6
No Broil.....	7
No Heat on Pure Convection	8
Oven Light (Low Voltage Halogen).....	9
Door Latch	10
Failure Codes F-7/F-8.....	11
Cooling and Convection Fan.....	12
Light 120 V Circuit	13
No Bake Broil (ERG, EGR, PGR).....	14
No Broil 36" Cell	15
Lower Oven / No Bake.....	16
Lower Oven ERC Harness.....	17
Membrane Test.....	18
19	
Cycle Charts	
Electric Ovens and Ranges	20
Gas Ranges.....	24
Dual Fuel Ranges	27
(including the small cell of the ERD48)	

ERC Quick Test

The process requires two people. To access the program, one person should stand at the oven, while the other is located at the circuit breaker. The person at the circuit breaker turns off the breaker and then the person at the oven depresses and holds the cooktime keypad. The person at the circuit breaker then turns the breaker back on. The display will show the 4-character identification code of the ERC. Example (1180)

You have 30 seconds between each test mode.

Note: if unit shows time of day start procedure over again.

Test 1

Push and hold convection bake
Bake element and convection fan activate.

Test 2

Push and hold Standard Bake
Bake element activate.

Test 3

Push and hold Pure Convection
Convection fan and convection element activate.

Test 4

Push and hold broil
Broil element activate. (on gas units - ignitor will activate.)

Test 5

Push and hold convection broil (select models)
Broil element and convection fan activate.

Test 6

Momentary push timer 2
Audible tone will sound.

Test 7

Push and hold stop time
Cooling fan activate.

Test 8

Momentary push clock
All LEDs will light up. Push + or - key pad. LEDs will display numbers
Example: 1111, 2222, 3333, 4444 etc.

Test 9

Last test door open, push and hold cook time for 10 seconds
Self clean latch motor activate. Door latch will complete one cycle.
The test will end and ERC will display the time of day.

NOTE:

Complete all tests within 30 seconds - otherwise you will see a failure code (F-0: Stuck key pad) displayed on the ERC.

OUTPUT VOLTAGE CHECK POINTS ON ERC/CLOCK CONTROL All Ranges And Wall Ovens

When programming the oven into a cooking cycle, you first select the desired mode on the touch membrane. Pressing this key sends a message to the ERC/Clock control, which in turn triggers 24 Volts DC to be sent to the main relay board through the connective harness. The desired relay (for example, Pure Convection) closes and distributes power to the desired components. In order to correctly diagnose this sequence you need a volt meter set on DC voltage. Drop the Bezel/Control panel down thus exposing the ERC/Clock and related wiring. Dropping the control panel down will expose the back side of the ERC/Clock control and main wiring harness. The connective harness will have 16 pins. Using a voltmeter take the test leads and insert into the backside of the main wiring harness

To take a voltage reading using the ERC connection chart below:

1. Set the voltage meter to DC voltage
2. Insert the test lead into the backside of the main harness (plugged into the backside of the ERC control.)

For example: if bake isn't working:

- a) Insert the test leads into connections (2-5)
- b) Program the unit into the bake cycle

The meter should read 22-24 Volts DC

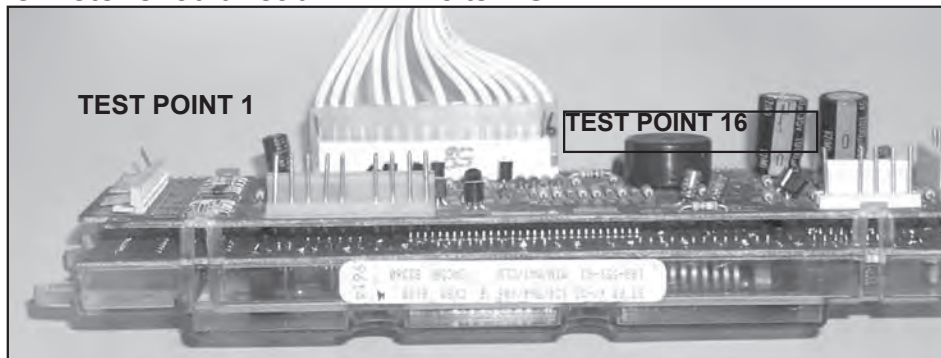

ERC CONNECTOR

Between Pins	Relay	Should Read
1-3	DBL	24 VOLTS
2-5	BAKE	24 VOLTS
2-6	BROIL	24 VOLTS
2-7	CONVECTION ELEMENT	24 VOLTS
2-9	CONVECTION FAN	24 VOLTS
1-11	DOOR MOTOR (LATCH MOTOR)	24 VOLTS
1-13	COOLING FAN	24 VOLTS

NO CLOCK DISPLAY

All Ranges And Wall Ovens

****Prior to going out on this call - make sure that the customer has re-set the circuit breaker.**

1. Check incoming voltage. Appliances must have 240 volts with a neutral.
2. Check voltage at main relay board at L1 and N just in front of the low voltage transformer. Should read 120 volts. Refer to picture for voltage test points.

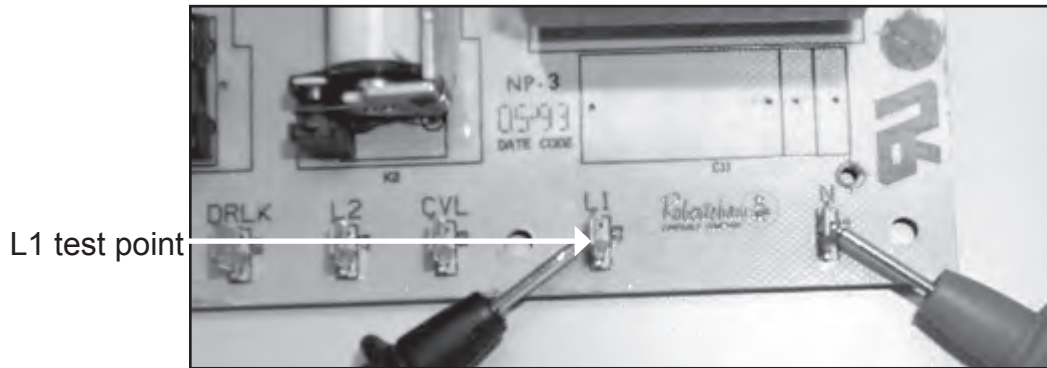

3. If you do not have the voltage at L1 and N check wires and connections at terminal block.
4. If you have 120 volts at L1 and N then check voltage at main ERC harness connection coming off ERC clock control. Refer to picture for test points 14 and 15. Should have 22-24 volts AC input to ERC/clock control.

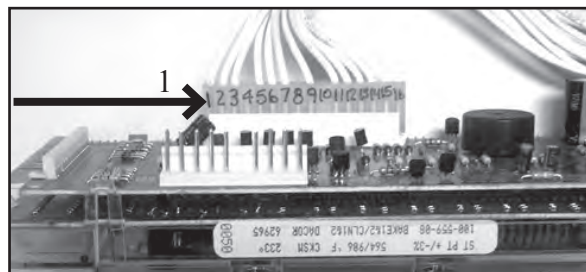

5. If you do not have 22-24 volts AC, suspect the main relay board or main harness.

NO BAKE

All Ranges And Wall Ovens

1. Check the incoming voltage to the unit. There should be 240 volts with a neutral.
2. Check power at the Dbl (double line relay) from (Com) to neutral. There should be 120 volts incoming to the Dbl. Refer to picture for testpoints. If voltage is ok, move to step 3.

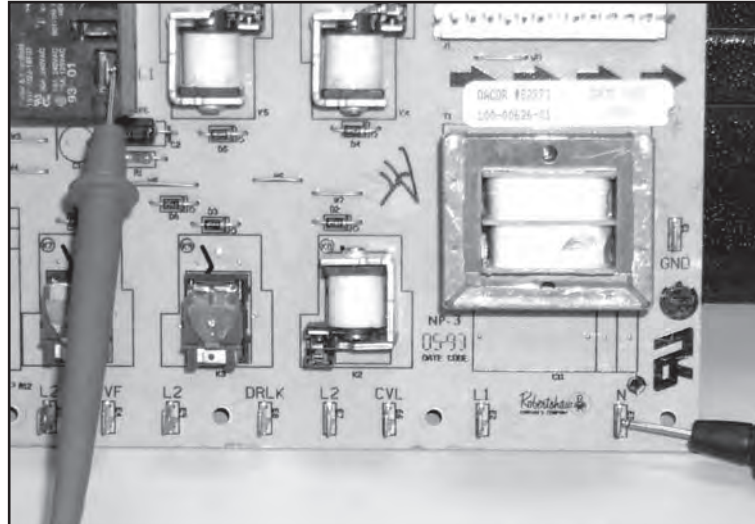

3. Program the unit into a bake cycle. Check voltage across Dbl (double line relay) (N.O. side) to BA relay for 240 volts. Refer to picture for test points. If no voltage replace relay board. If you have 240 volts go to step 4.

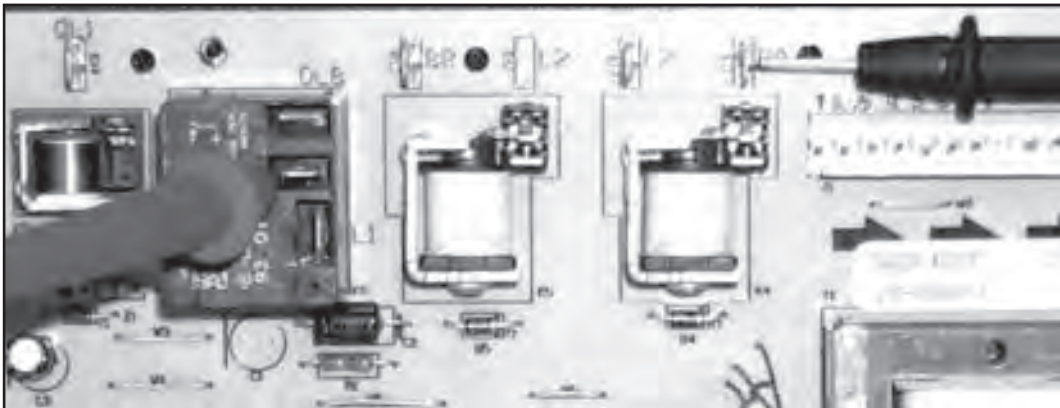

4. Check the HTC (high temp cutout) for open circuit. HTC is a NC switch. The HTC is located by the latch assembly and has a re-settable switch. (see picture)



NO BROIL

All Electric/Dual-Fuel Ranges And Wall Ovens

1. Check the incoming voltage to the unit. There should be 240 volts with a neutral.
2. Check power at the Dbl (double line relay) from (Com) to neutral. There should be 120 volts incoming to the Dbl. Refer to picture for testpoints. If voltage is ok, move to step 3.

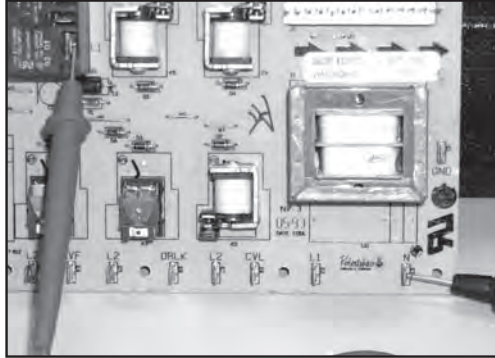

3. Program the unit into a broil cycle. Check voltage across the DBL (double line relay) N.O. output side and BR relay (Broil relay) For 240 Volts. Refer to picture for test points. If you have voltage present go to step 4. If you do not have voltage replace relay board.

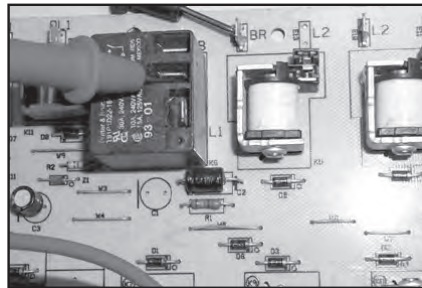

4. Check the HTC (high temp cutout) for open circuit. HTC is a NC switch. The HTC is located next to the latch assembly and has a re-settable switch. (see picture)

Re-set Button

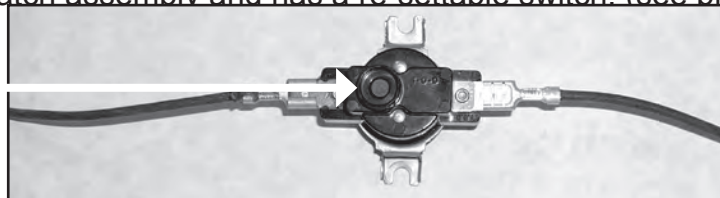

There is also a user programmable option to set the cooling fan off temperature to 200, 300, 400 or 450 degrees.

To change the temperature:

1. Touch Broil pad - enter temp as 500 degrees or higher.
2. Push and hold Broil pad for 5 seconds - COOL will show in the ERC display
3. Adjust fan shut off temp with the +/- pad. (000 = 300 degrees, all other settings will display temp).
4. To exit the mode - press cancel.

Recommended factory setting is 300 degrees

This will only work on EC, MC and PC ovens

PURE CONVECTION - NO HEAT

Wallovens, Dual Fuel and Electric Ranges

1. Check the incoming voltage to the unit. There should be 240 volts with a neutral.
2. Program the unit into pure convection. Check power at the Dbl (double line relay) from (Com) to neutral. There should be 120 volts incoming to the Dbl. Refer to picture for test points. If voltage is ok, move to step 3.

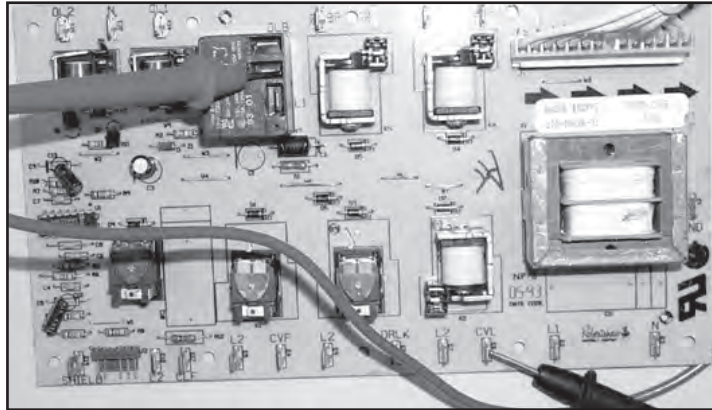

3. Check voltage across the DBL (double line relay) NO output side and the CVL (convection element relay) for 240 volts. Refer to picture for test points.)
If you have voltage present move to step 4
If you do not have voltage replace relay board.

Double line relay

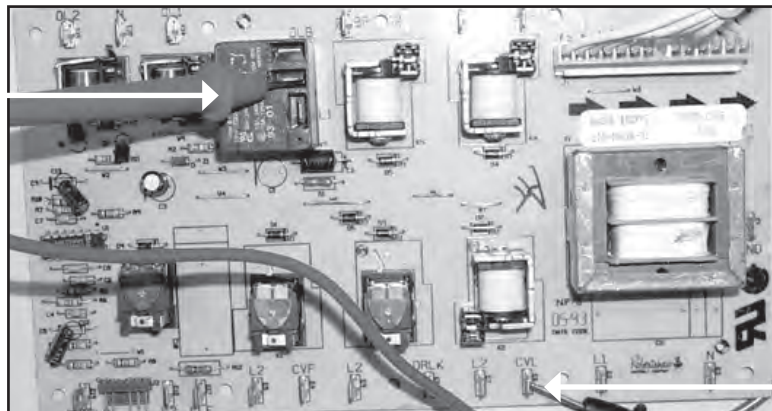

Convection Element Relay

4. Check the HTC (high temp cutout) for open circuit. HTC is a NC switch. HTC is located by the latch assembly and has a re-settable switch. (see picture)

Re-set Button

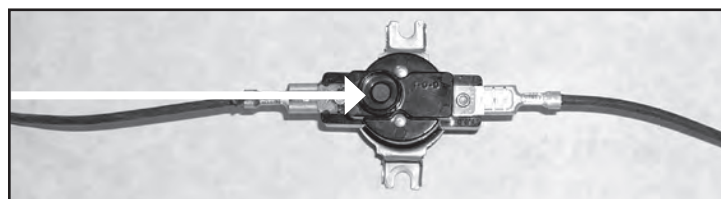

HALOGEN OVEN LIGHTS

Electric and Dual Fuel Ranges, Wall Ovens

1. Check input voltage to the light transformer at the primary side across terminal 1 and 5. Should read 240 volts. (see picture) If you do not have 240 volts across 1 and 5, check wiring back to the terminal block. If there is 240 volts present at 1 and 5 go to step 2. (see picture)

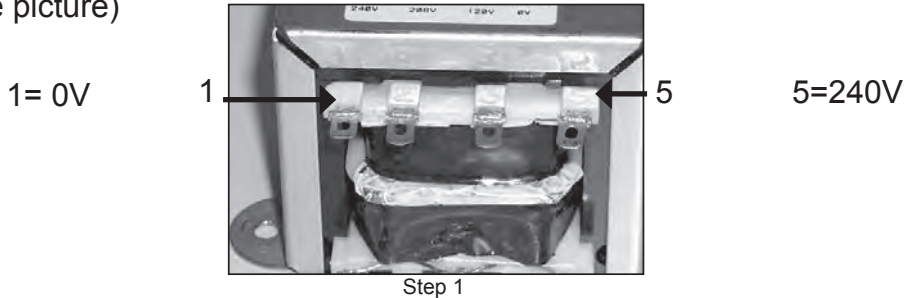

2. Check voltage at the light transformer on the secondary side across terminal 6 and 8. Should read 12 volts. If you do not have 12 volts present at terminal 6 and 8 replace light transformer. If you do have voltage present go to step 3.

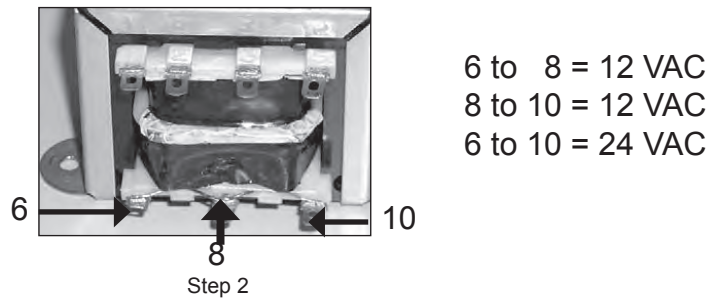

3. Check voltage from the main relay board at terminal N which is to the left of OL1 relay. Should have 12 volts present at N all the time. If you do not have 12volts present re-check steps 1 and 2 or replace light transformer. If you do not have 12 volts present go to step 4. (see picture)

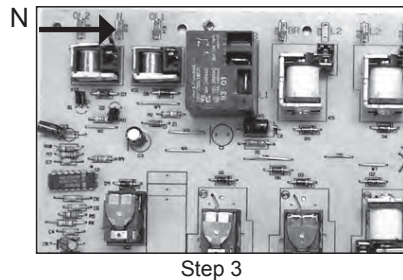

4. Check voltage at OL1 on main relay board. Should have 12 volts present after OL1 relay closes. If you do not have voltage present recheck steps 1-3 or replace relay board. If you do have voltage present Check wiring to light socket and light bulb.

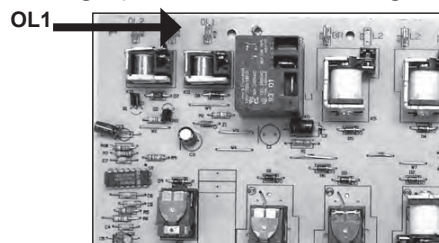

DOOR LATCH NOT RUNNING

All Models

1. Check voltage at L2 just to the left of the DRLK relay. (door lock relay) you should have 120V present. See picture for test points.

If there is no voltage present, check wiring from L2 back to terminal block. If you have voltage at L2 go to step 3

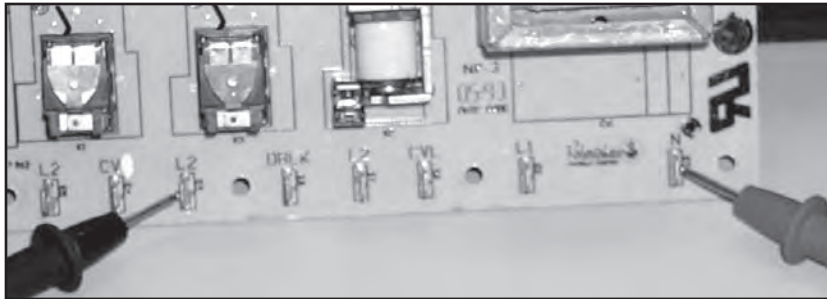

2. Program oven into self-clean cycle.
3. Check voltage from the DRLK (door lock relay) to neutral. See picture for test points. Should have 120 Volts. If no voltage is present replace relay board. If voltage is present check wiring to door latch assembly. If ok replace door latch assy.

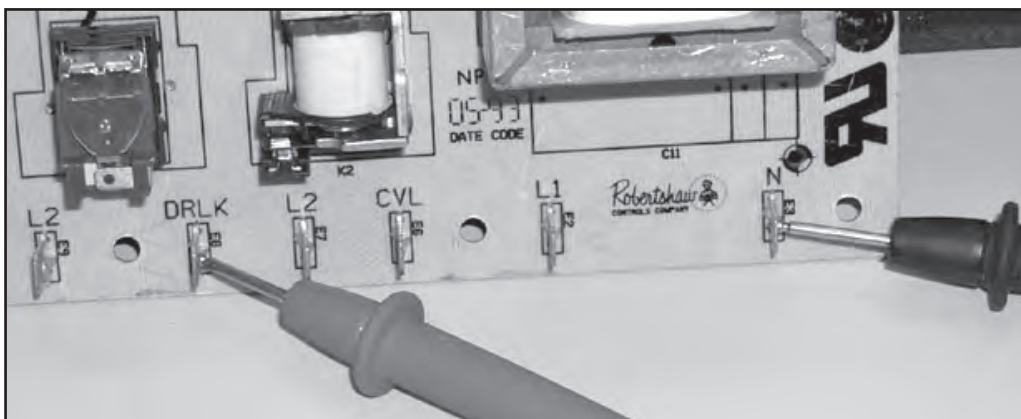

4. If you do not have 120VAC, check for (+ or -) 24V DC at molex connector on the relay board. Pins 1 and 9 on relay board should read 24V DC (+or-); if not then replace the relay board.

F-7, F-8

Door Failure Codes

For Single Wall Ovens and Ranges

Latch Switch - Phase Switch NC
Lock Switch NC

If the oven is in the Self Clean cycle, and after a short period of time the latch locks and the Self Clean display reverts back to the time of day check the latch switches on the latch assembly for an open latch switch or an open wire coming off of the latch switches to the back of the ERC control. You should also check to be sure that the latch is wired correctly

If oven is programmed into a Self Clean cycle and you get the word DOOR in the clock display:

- 1) Check for DC voltage out of the back of the ERC control at the 8 pin connector at J4. There are 5 colored wires in the 8 pin connector - they are (1-yellow, 1-orange, 1-brown, 2-white.) Check for power at the brown wire - there should be 22-24 volts dc. If no voltage is present at the brown wire; check the wiring to ground and the latch switches for a grounded wire or miswired switches.
- 2) Check voltage at J4 - the 8 pin connector coming off the back of the ERC clock control should read 22-24 volts dc at all times. This the voltage feeds the latch switches. If no voltage is present out of the ERC (clock control), replace the ERC.
- 3) Check the alignment of the door latch with the outer/inner door liner when it locks. It may not allow the door latch to lock properly and cause the door switches to activate properly

F-7, F-8 Door Failure Codes Wall Ovens and Ranges

Single Oven



Single Oven

- 1 - Com Brown Wire
- 2 - N/C Yellow Wire
- 3 - N/O
- 4 - N/C Orange Wire
- 5 - N/O
- 6 - Com Double Brown Wire

Double Oven

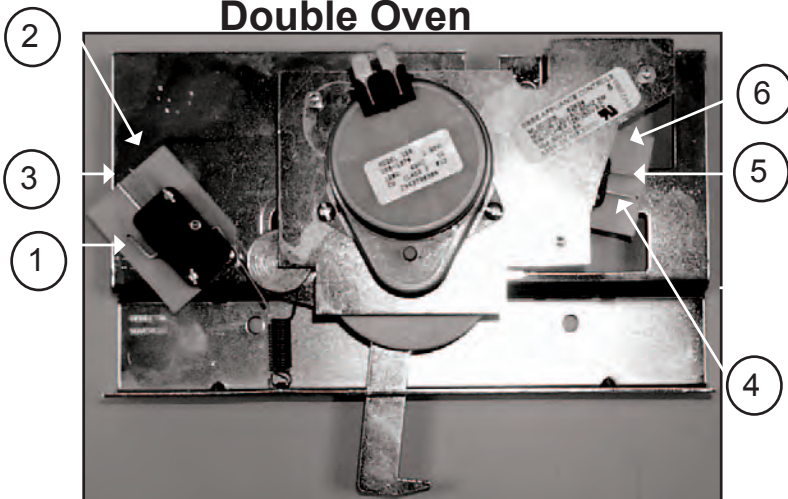

Double Oven

- 1 - Com Brown Wire
- 2 - N/C Yellow Wire
- 3 - N/O
- 4 - N/C Orange Wire
- 5 - N/O
- 6 - Com Double Brown Wire

Lower Oven

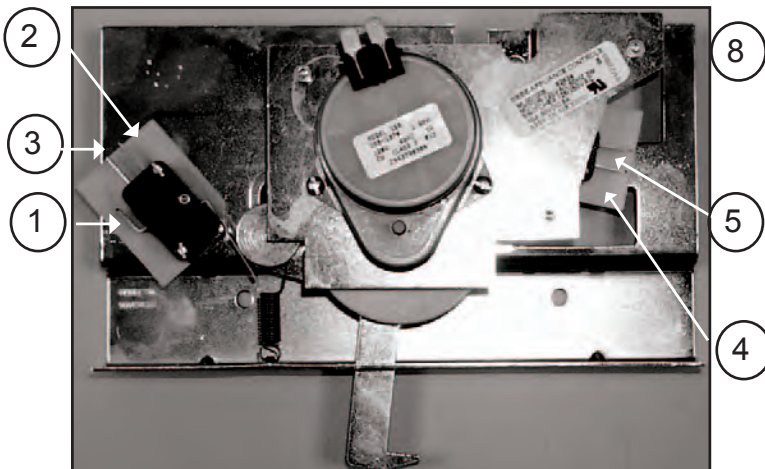

Lower Oven

- 1 - N/C Violet wire
- 2 - N/C Yellow wire
- 3 - N/O Black or Yellow wire
- 4 - N/C Orange Wire
- 5 - Empty
- 6 - Com Brown Wire

NO COOLING FAN

All Ranges And Wall Ovens

1. Program unit into a cooking cycle. The cooling fan should come on right away. ** If cooling fan doesn't come on, check voltage at CVF or CLF relay (cooling fan relay) side to neutral. Should read 120 VAC. If voltage is not present replace main relay board. If voltage is present check for open wires going to cooling fan. If wiring ok, replace cooling fan motor assembly.

**Note: On all models except for the PGR and RSG the cooling fan turns on at an oven temp of 180 to 230 degrees

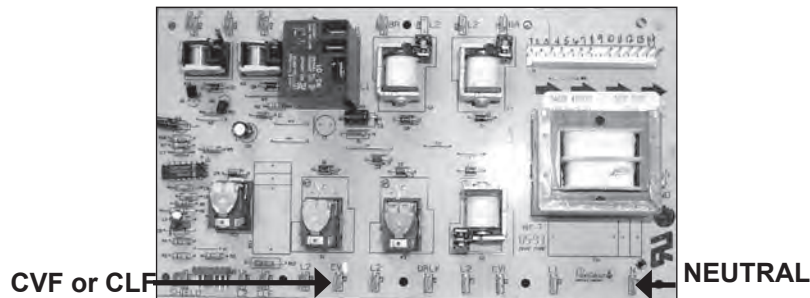

NO CONVECTION FAN

All Models

1. Program the oven into convection bake.
2. Check voltage at L2 just to the left of the CV (convection relay), should have 120 volts. See picture. If no voltage check wiring back to the terminal block. If you have voltage present at L2. Go to step 3.
3. Check voltage out of the CV (convection relay) for 120 volts. See picture for test points. If no power out of CV relay replace relay board. If there is voltage present check wiring, convection motor and connections.

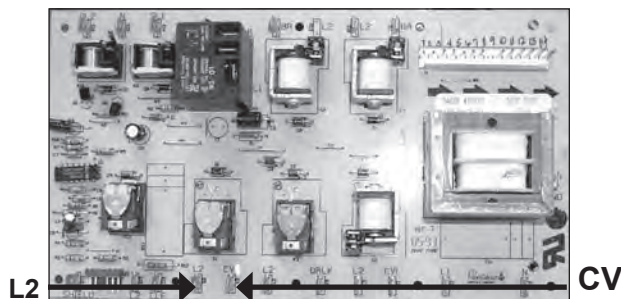

LIGHT NOT WORKING

PGR, RSD, RSE 120V Light Circuit

1. Check voltage for light circuit at main relay board at terminal N, just to the left of OL1 (oven light relay one) Should have a constant 120 volts. (see picture) If no voltage there check wiring back to terminal block. If you do have voltage present go to step 2.

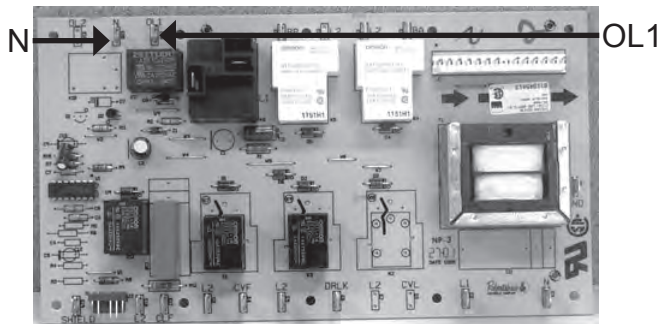

2. Activate the light circuit by pressing the touch pad and listen for the OL1 relay to close then check for 120 volts at OL1. (see picture) if no voltage present replace relay board. If the OL1 (oven light relay 1) doesn't close or you don't hear relay close go to step 3.
3. If OL1 relay doesn't close you need to check the membrane touch pad (refer to membrane test points in this manual) You will also need to check the small ribbon connection that is coming off of the touch membrane to the main relay board for proper connection. Step 4 (see picture)
4. You can bypass the membrane touchpad to activate the light circuit. Remove the small ribbon connection that is coming off the touchpad to the main relay board. Take a jumper wire or a pocket screw driver and jump across pins one and two. (see picture) If OL1 relay closed the problem is in the touch pad. If OL1 relay doesn't close then the problem is in the main relay board.

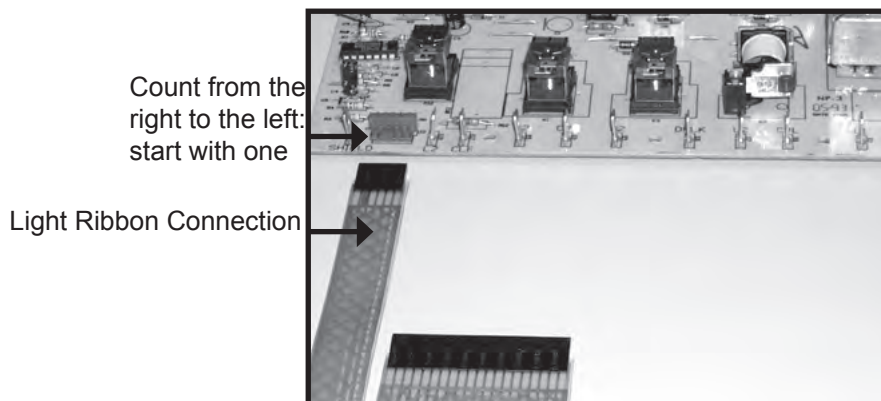

NO BAKE/BROIL

EGR, ERG, PGR

Here is a list of functional parts that should be working for the bake/broil to light..

Main Relay Board

Cooling blower

Air switch (sail switch)

Dual gas valve

Bake Igniter

All of these elements must be working in order for the bake or broil burner to function.

NO BAKE

1. Check incoming line voltage to the DBL (double line relay) NO side and neutral. Should have 120 VAC. If no voltage present trace wiring back to terminal block. If voltage is present go to step 2.

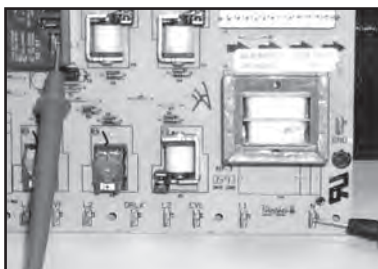

2. Program the unit into Bake or Broil.
Check voltage at the DBL (double line relay) com side to neutral. Should read 120 VAC. If no voltage present replace main relay board. If voltage is present then check if cooling fan is running. If cooling fan is not running check wiring and cooling fan motor. If cooling fan is running then check the air switch/sail switch that is mounted to the cooling fan assy. You must remove cooling fan to gain access to air switch/sail switch.

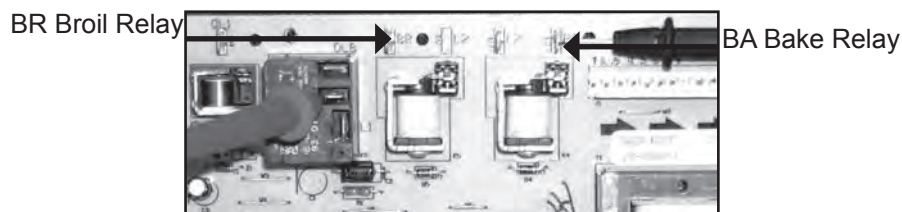

****Note:** The cooling fan should turn on immediately when any cooking cycle is programmed.

Here is a list of functional parts that should be working for the bake/broil to light..

Main Relay Board
Cooling blower
Air switch (sail switch)
Dual gas valve
Bake Igniter

Note: ERG30's had a sail switch prior to SN KC1230128. On 6-7-01 the sail switch was replaced with an automatic reset switch.
PGR30's unit with a serial level KB0000000 and KA0000000 had a sail switch - those with a KC0000000 and above have an automatic limit switch.

All of these elements must be working in order for the bake or broil burner to function.

NO BAKE

1. Check incoming line voltage to the DBL (double line relay) NO side and neutral. Should have 120 VAC. If no voltage present trace wiring back to terminal block. If voltage is present go to step 2.

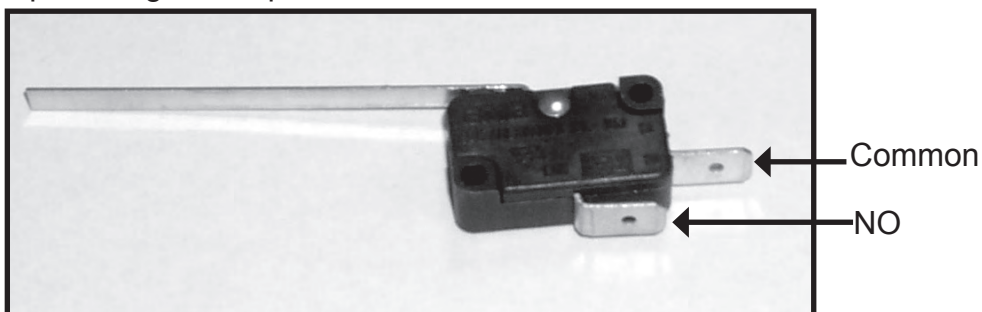

2. Program the unit into Bake or Broil.
Check voltage at the DBL (double line relay) com side to neutral. Should read 120 VAC. If no voltage present replace main relay board. If voltage is present then check if cooling fan is running. If cooling fan is not running check wiring and cooling fan motor. If cooling fan is running then check the air switch/sail switch that is mounted to the cooling fan assy. You must remove cooling fan to gain access to air switch/sail
3. The air switch/sail switch is a NO switch you should have 120 VAC to that switch. Take a voltage check from one side of the wire to neutral - it should read 120VAC.

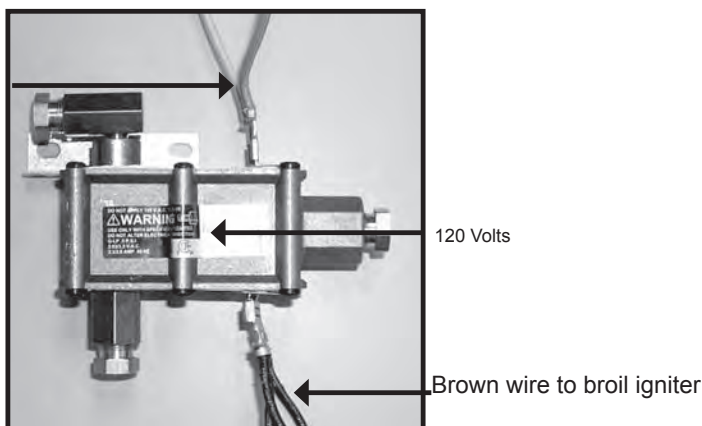

NO BROIL 36" Cell

ERD30, 36, 48

1. Program unit into the broil cycle.
Take an amp reading at the broiler igniter. You should have 3.1 to 3.3 amps. Or take a voltage reading at the main relay board. At the main relay board take a voltage check from the BR (broil relay) to neutral should read 120 volts AC. If no voltage out of the BR relay - replace relay board. If you have voltage out of the relay board check the HTC (High temp cutout) to see if the HTC has tripped.
(Remember the broil HTC has the white wire hook to it. You can do this by pushing down on the reset button located in the center of the HTC. If the HTC won't reset or is open, replace HTC. If the HTC is good, go to step 2.
2. Dual Valve: The HTC (Hi temp cutout) feeds the neutral into the dual valve and the dual valve feeds the neutral to the broil igniter. If the dual valve is bad, the broil igniter won't be energized.

LOWER OVEN / NO BAKE

ECS/ECD, MCS/MCD, PCS/PCD

1. Check the incoming voltage to the unit. There should be 240 volts with a neutral.
2. Check power at the Dbl (double line relay) from (Com) to neutral. There should be 120 volts incoming to the Dbl. Refer to picture for testpoints. If voltage is ok, move to step 3.
3. Program the unit into a bake cycle. Check voltage across Dbl (double line relay) (N.O. side) to BA relay for 240 volts. Refer to picture for test points. If no voltage replace relay board. If you have 240 volts go to step 4.
4. Check the HTC (high temp cutout) for open circuit. HTC is a NC switch. The HTC is located by the latch assembly and has a re-settable switch. (see picture)

N.O. Connection

BA Relay

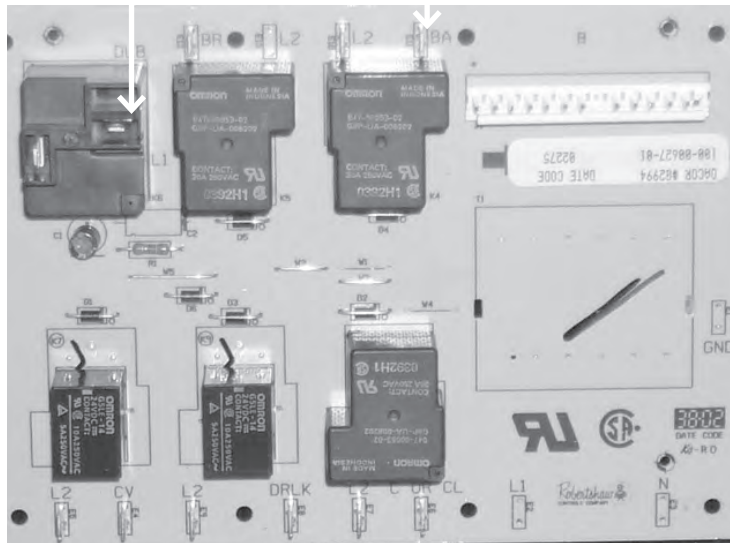

Reset Button

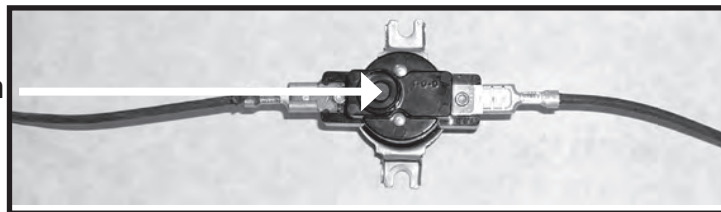

DOUBLE WALL OVENS

Lower Oven ERC Harness

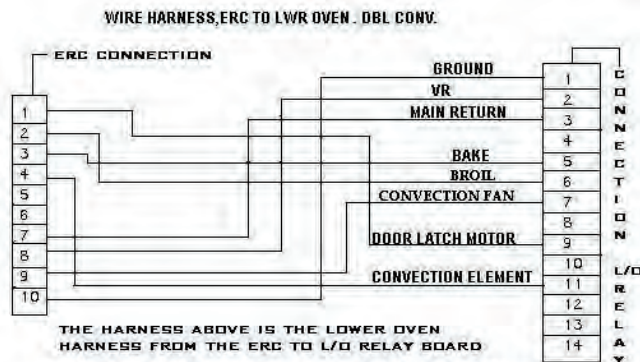

WHEN THE ERC/ CLOCK CONTROL IS PROGRAMED INTO A COOKING FUNCTION, THE ERC/CLOCK CONTROL SENDS (22-24 VOLTS DC) TO THE L/O RELAY BOARD FOR THAT COOKING FUNCTION. EXAMPLE: IF THE L/OVEN IS PROGRAMED INTO A BAKE CYCLE, THE ERC/CLOCK WOULD SEND (22-24 DCV) TO THE L/OVEN RELAY BOARD TO CLOSE THE BAKE RELAY. TO TEST SET A VOLT METER TO READ (DCV) INSERT THE TEST LEADS INTO THE REAR OF THE WIRE HARNESS THAT PLUGGED INTO THE BACK OF THE ERC/CLOCK CONTROL AT (J-6) PIN/WIRE LOCATION (10-3). THEN PROGRAM THE L/OVEN INTO BAKE YOUR VOLTAGE SHOULD BE (22-24 VDC). REF TO OTHER TEST POINT BELOW

BAKE:10-3
 BROIL:10-2
 CONV. ELEMENT:10.4
 CONV. FAN:10-9
 LATCH MOTOR:10-1

When the ERC/Clock Control is programmed into any cooking mode, the ERC/Clock control sends 22-24 volts DC into the relay board to power that function. For example: if the lower oven is programmed into a bake cycle, the ERC Clock control would send 2DCV to the Lower Oven relay board to close the bake relay. To set a volt meter to read DCV, insert the test leads into the rear of the wire harness that plugged into the back of the ERC/ Clock control at J-6 pin wire location 10-3. Then program the lower oven into bake. Voltage should be 22-24 VDC.

Other test points shown below:

Bake	10-3
Broil	10-2
Convection Element	10-4
Convection Fan	10-9
Latch Motor	10-1

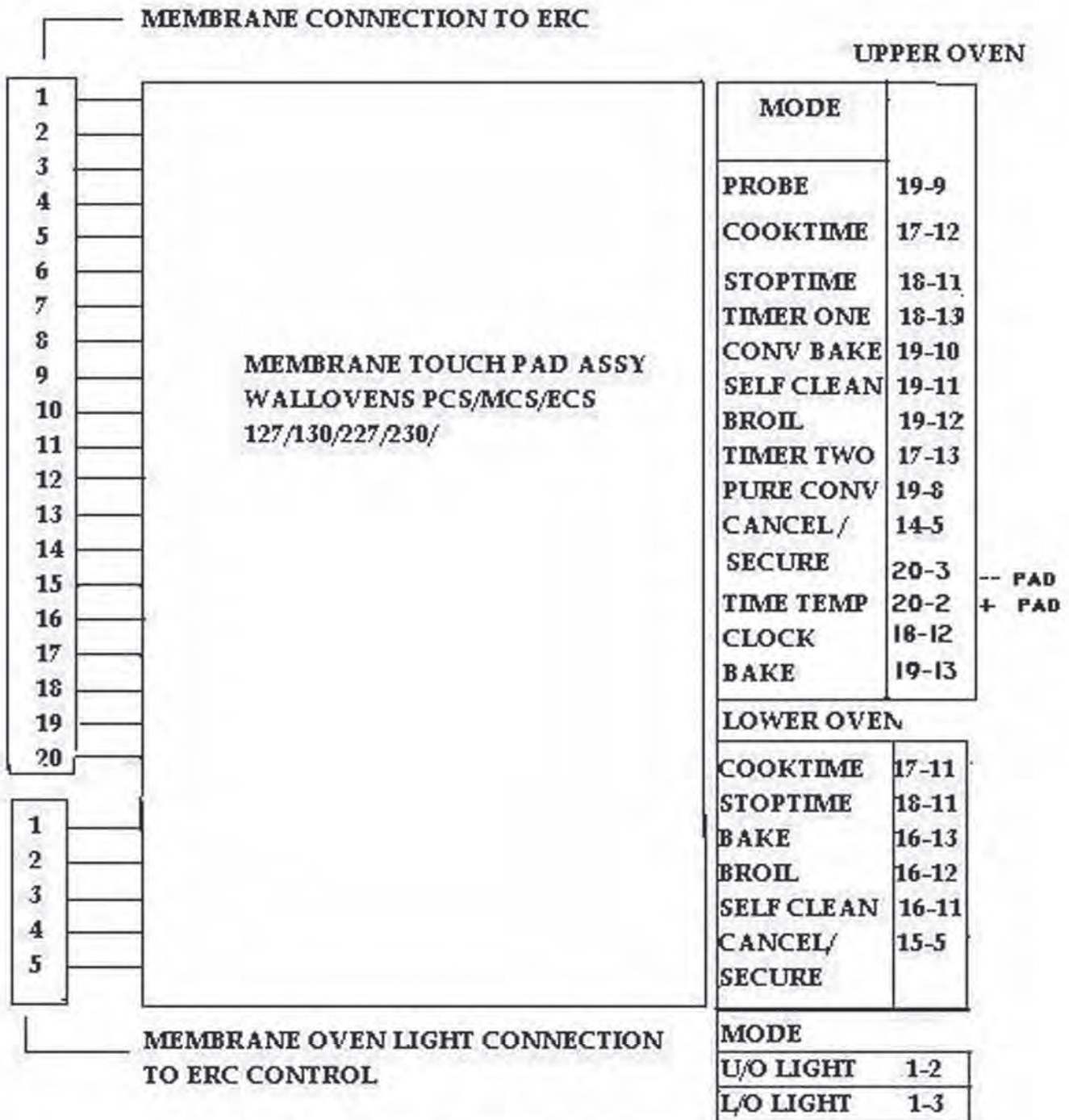

This membrane chart shows the membrane touch circuit.

For example: pull the main connector off the ERC control and insert the test leads into the connector at points 19-13. Press the bake function on the upper oven touch pad to show a closed circuit.

All Electric Ovens and Ranges

Pure Convection

Refer to Main Wiring Harness for test points
2 & 7 Convection Element
2 & 9 Convection Motor

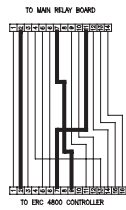

LOW VOLTAGE CABLE
Use 16 Pt connection
side of ERC harness to test

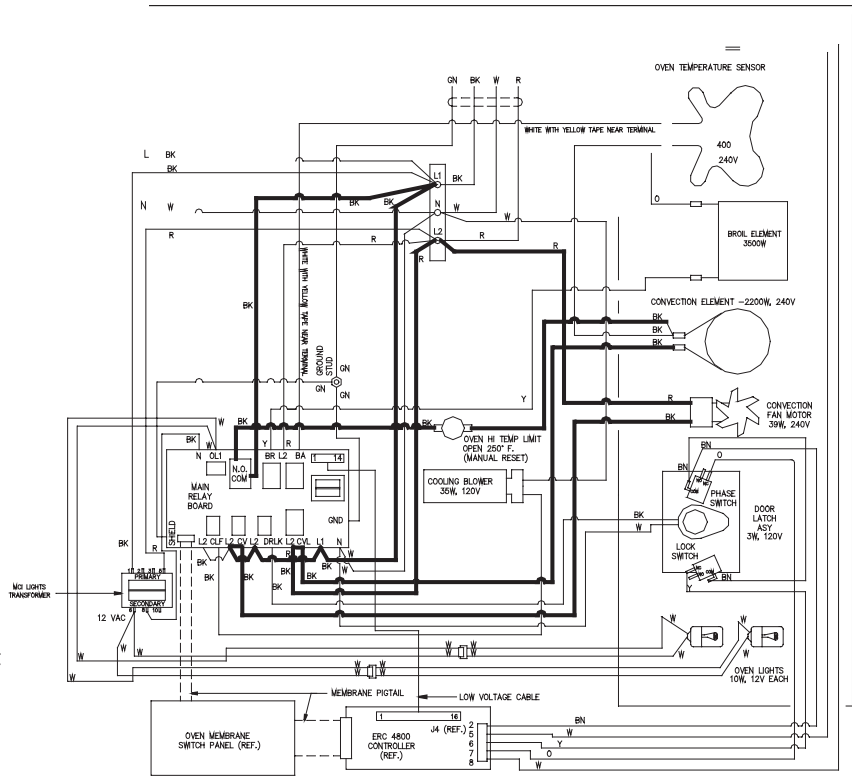

Convection Bake

Test across 2 & 5 on main wire harness - for Bake it should read 22-24 VDC.
Test across 2 and 9 for Convection Motor.
It should read 22-24 VDC

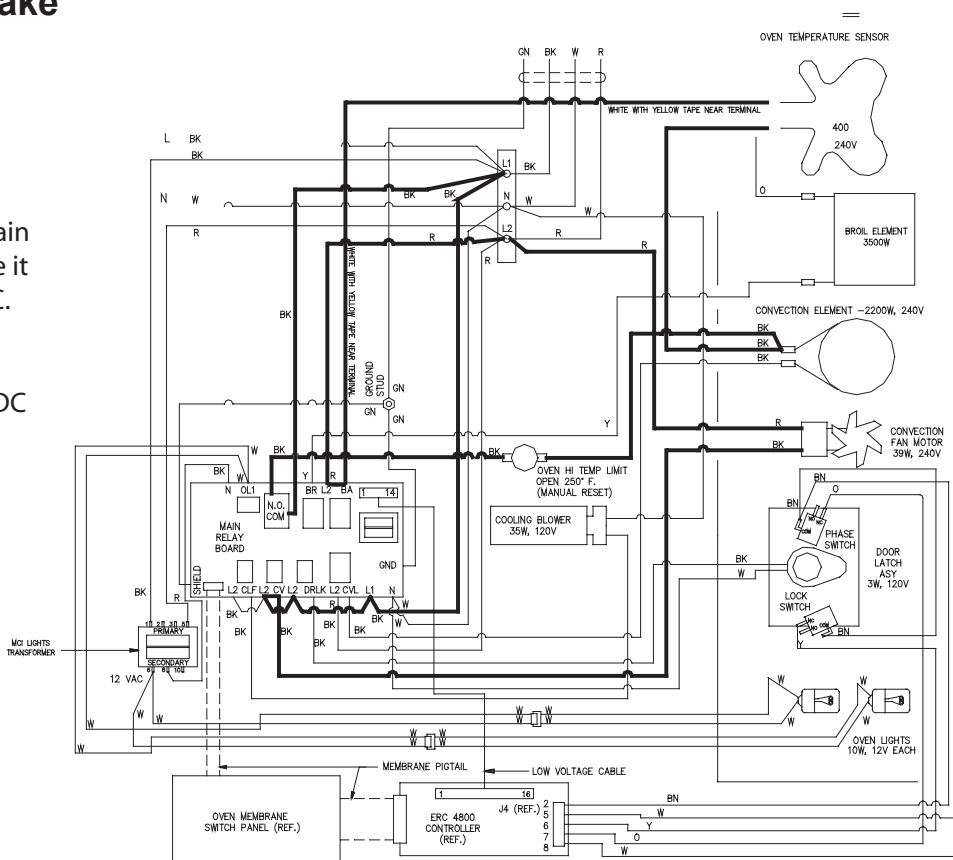
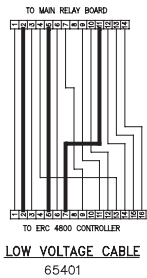

All Electric Ovens and Ranges

Cooling Fan

Cooling Fan
1&3
Cooling Fan
180°/225°
Refer to the 16
pin side of the
ERC wire
harness to test

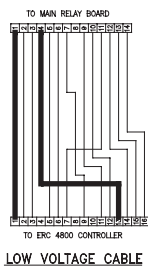

65401

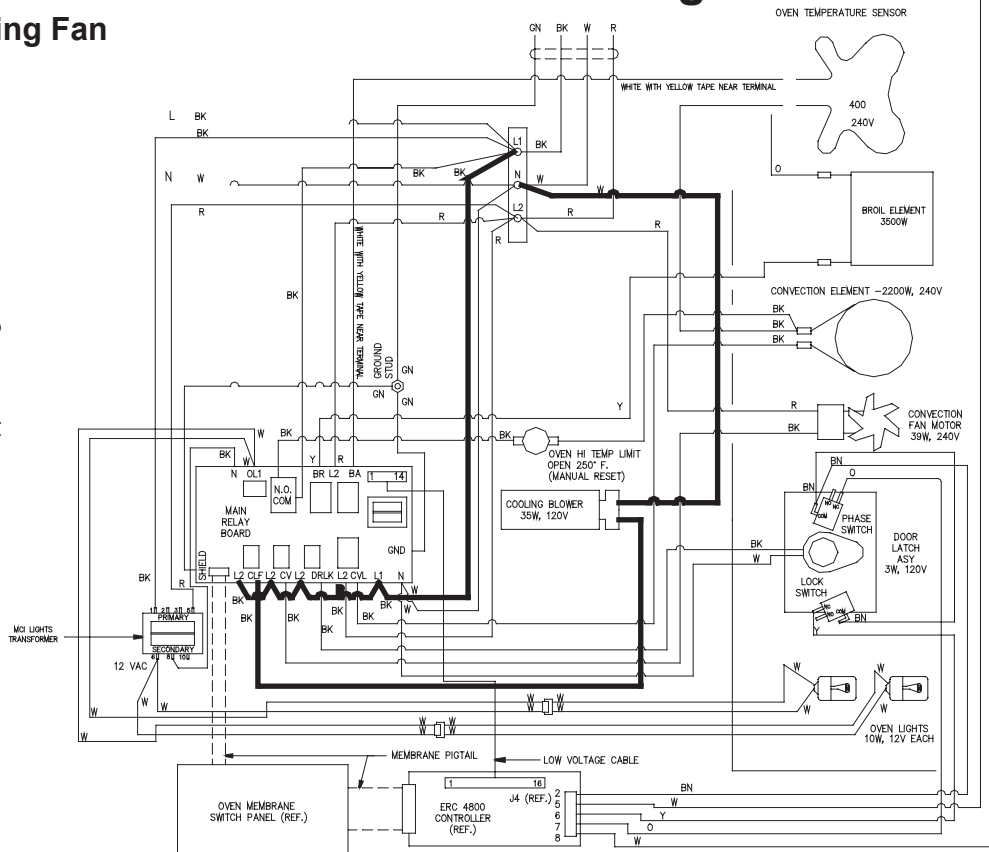

Light Circuit

Light Circuit

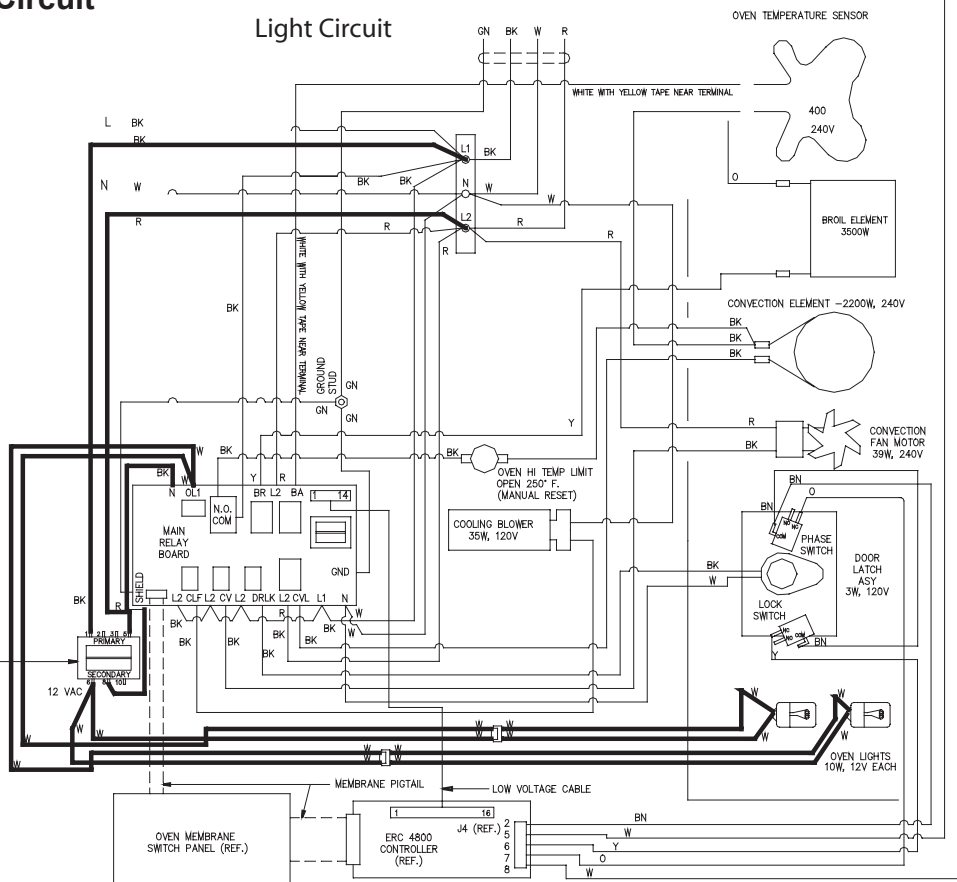
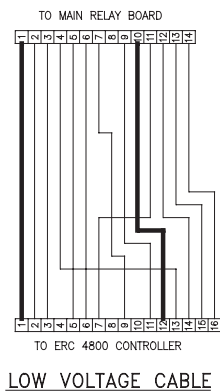

All Electric Ovens and Ranges

Self Clean

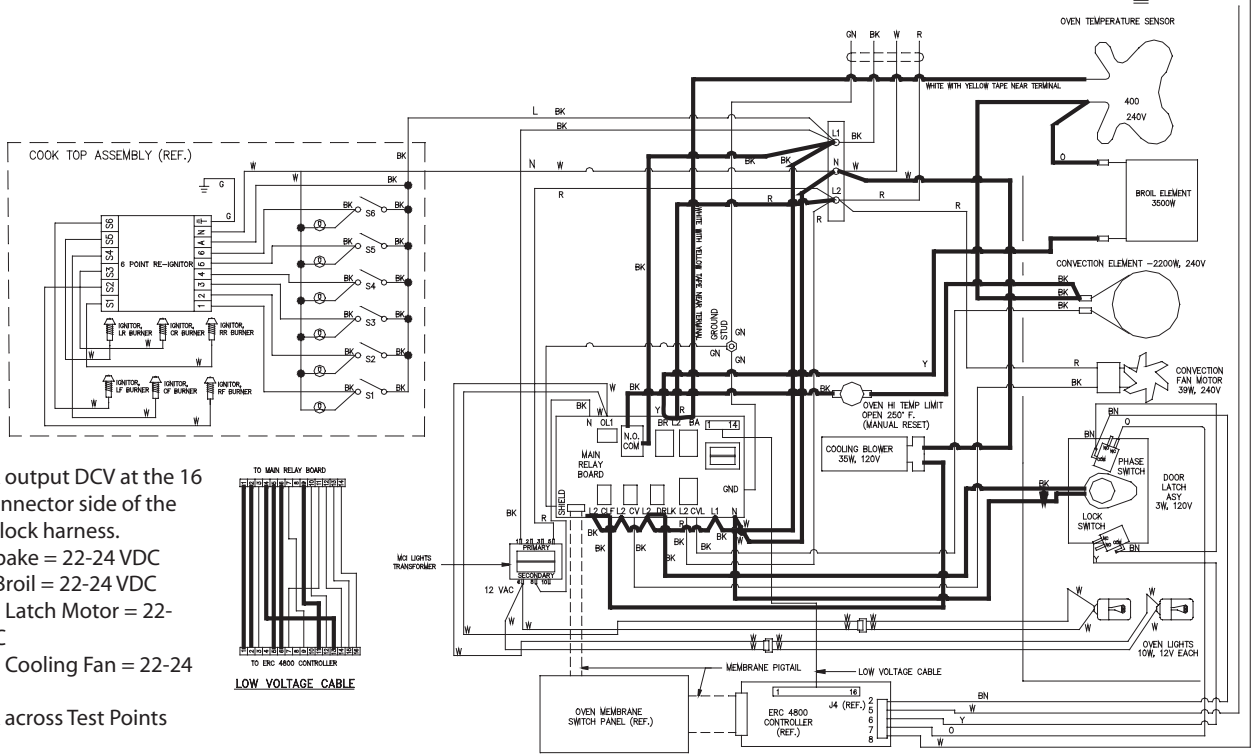

Check output DCV at the 16 pin connector side of the ERC/Clock harness.
 2 & 5 bake = 22-24 VDC
 2 & 6 Broil = 22-24 VDC
 1 & 11 Latch Motor = 22-24VDC
 1 & 13 Cooling Fan = 22-24 VDC
 Check across Test Points

Broil

Test points on harness 16 pin side.
 Set meter to VDC. CK voltage across 2 & 6.
 Should read 22-24 VDC in broil cycle.

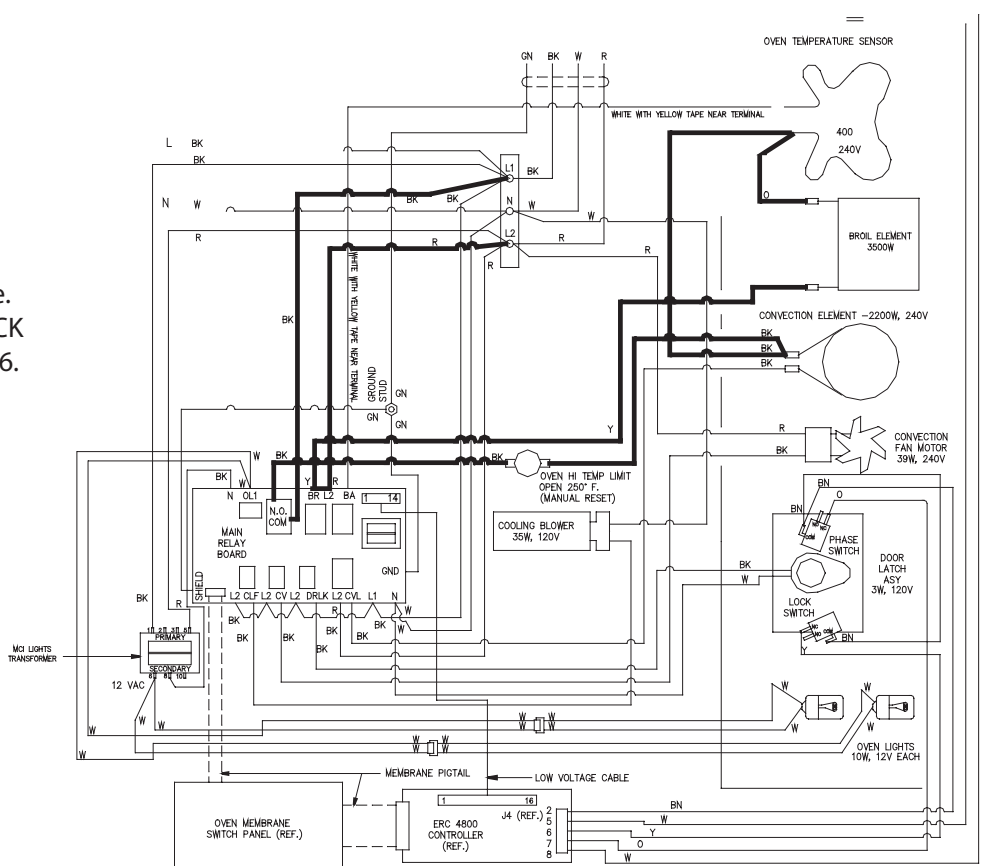
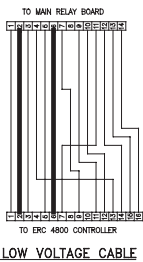

Gas Ranges

Bake

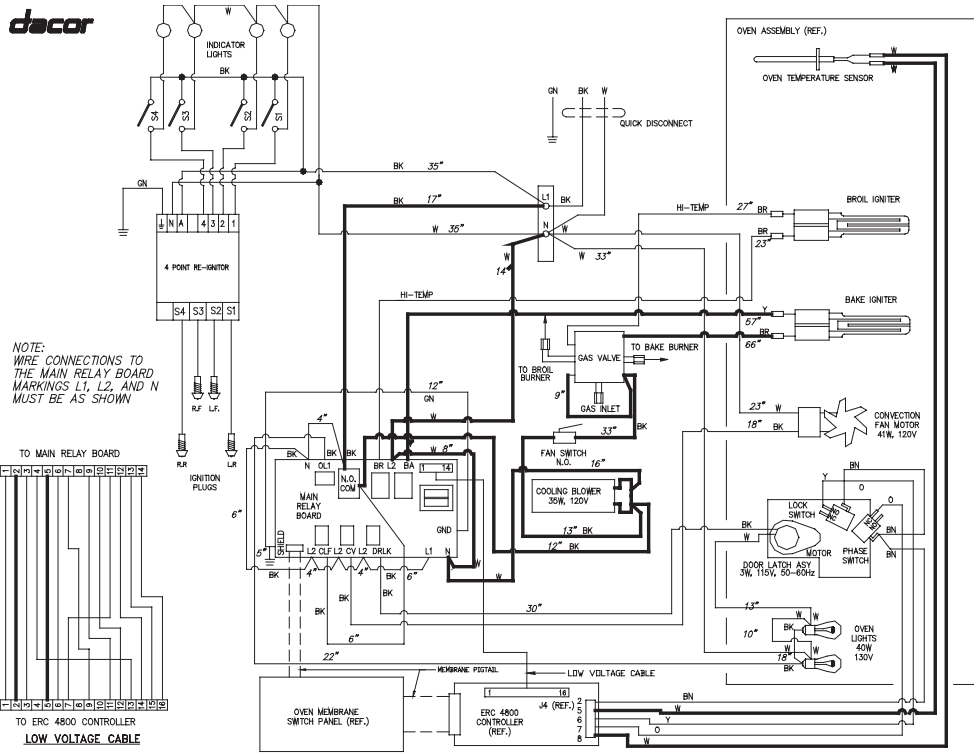

Convection Bake

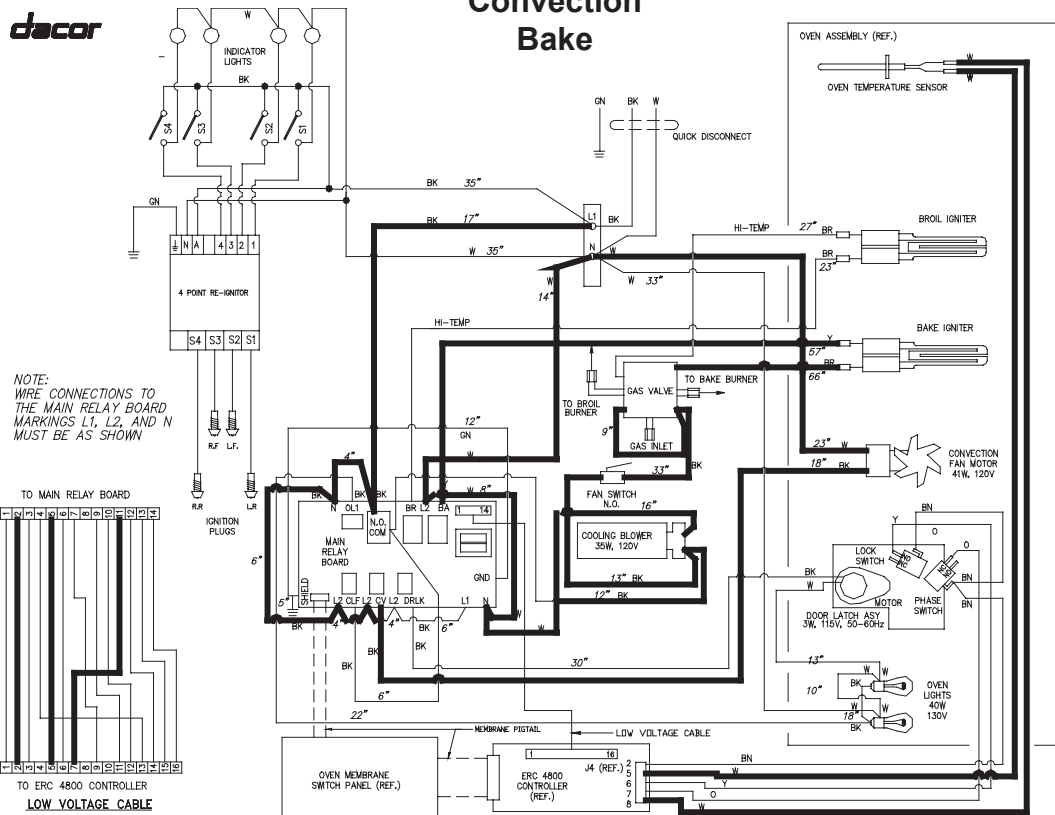

Gas Ranges

dacor

Self-Clean

Check across 2 and 5 for bake from the 16 pt connection of the main wire harness for 22-24 VDC and 1 and 11 for the cooling fan.

NOTE:
WIRE CONNECTIONS TO THE MAIN RELAY BOARD MARKINGS L1, L2, AND N MUST BE AS SHOWN

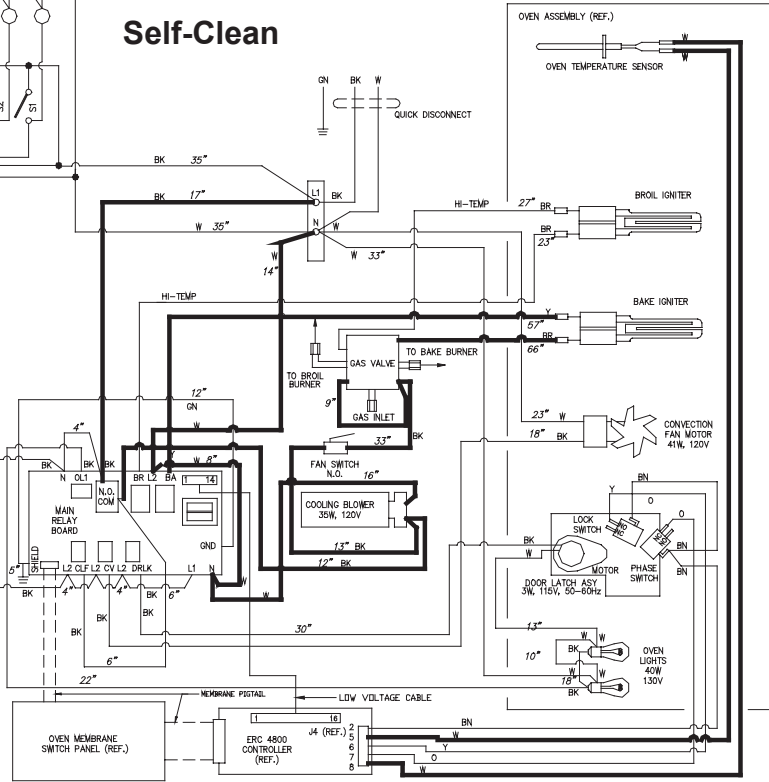
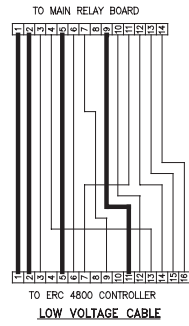

Preheat

dacor

Check across 2 and 5 for bake from the 16 pin connection of the main wire harness of the ERC for the bake coil.

NOTE:
WIRE CONNECTIONS TO THE MAIN RELAY BOARD MARKINGS L1, L2, AND N MUST BE AS SHOWN

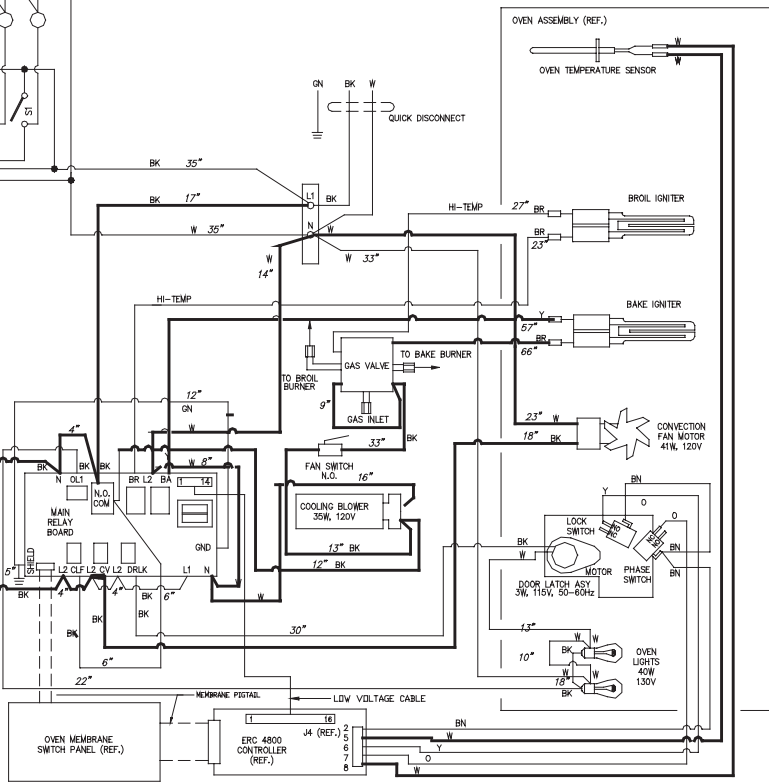
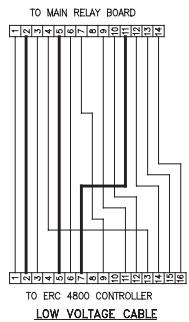

Gas Ranges

dacor

Broil

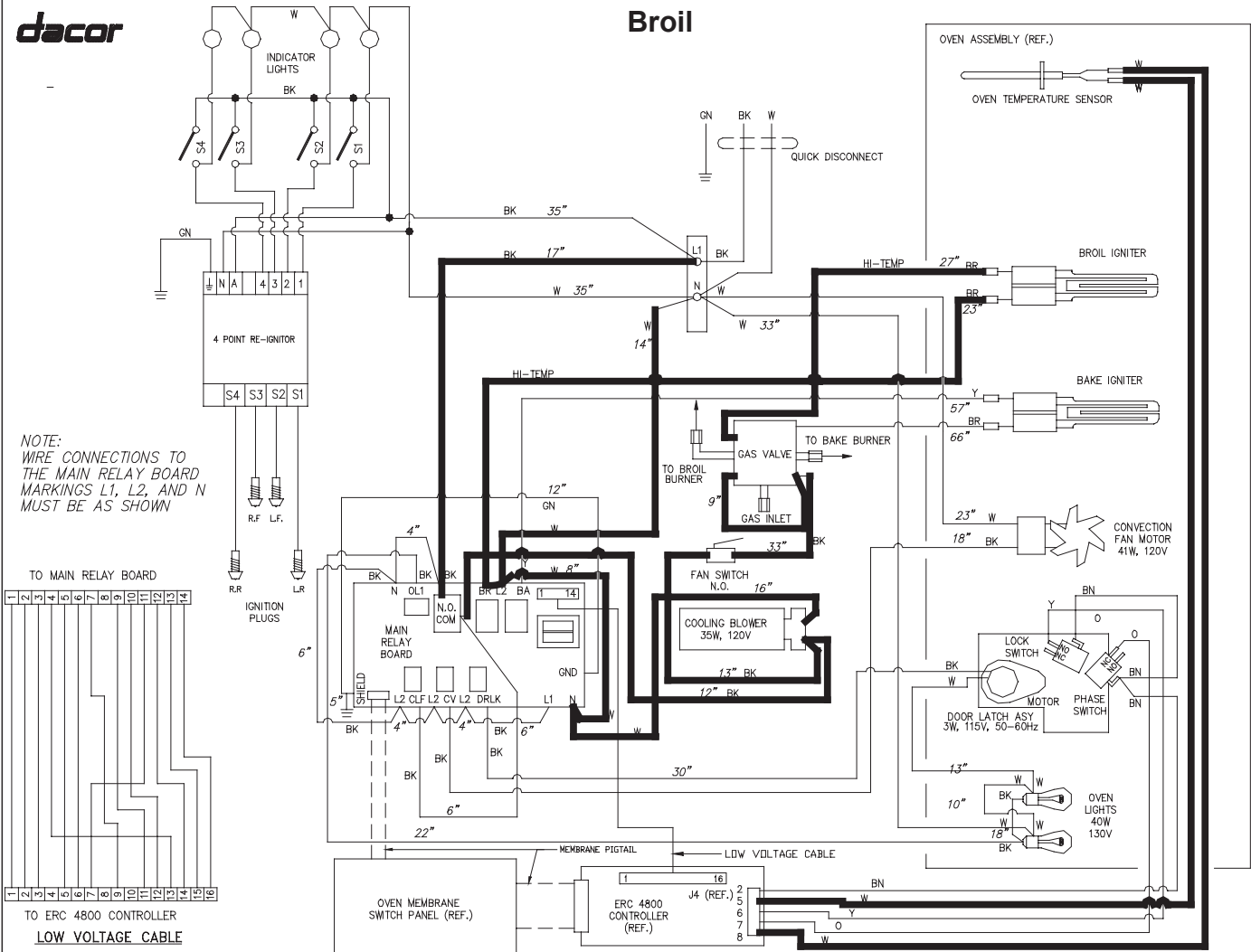

Dual Fuel Ranges

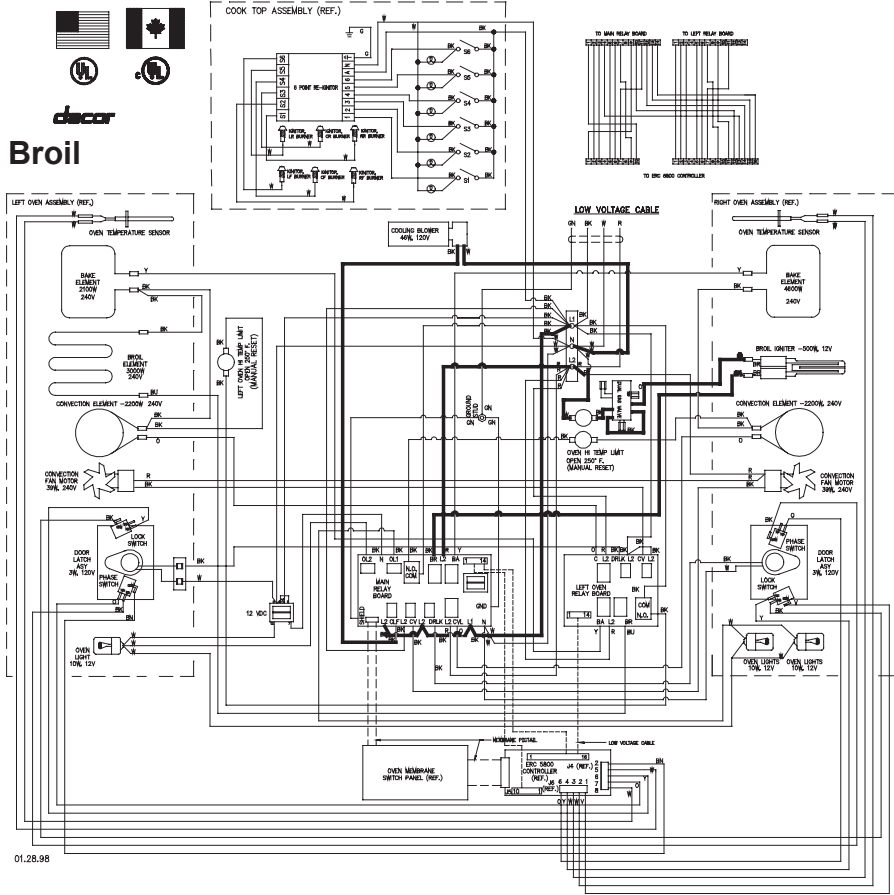

85470 01.28.98

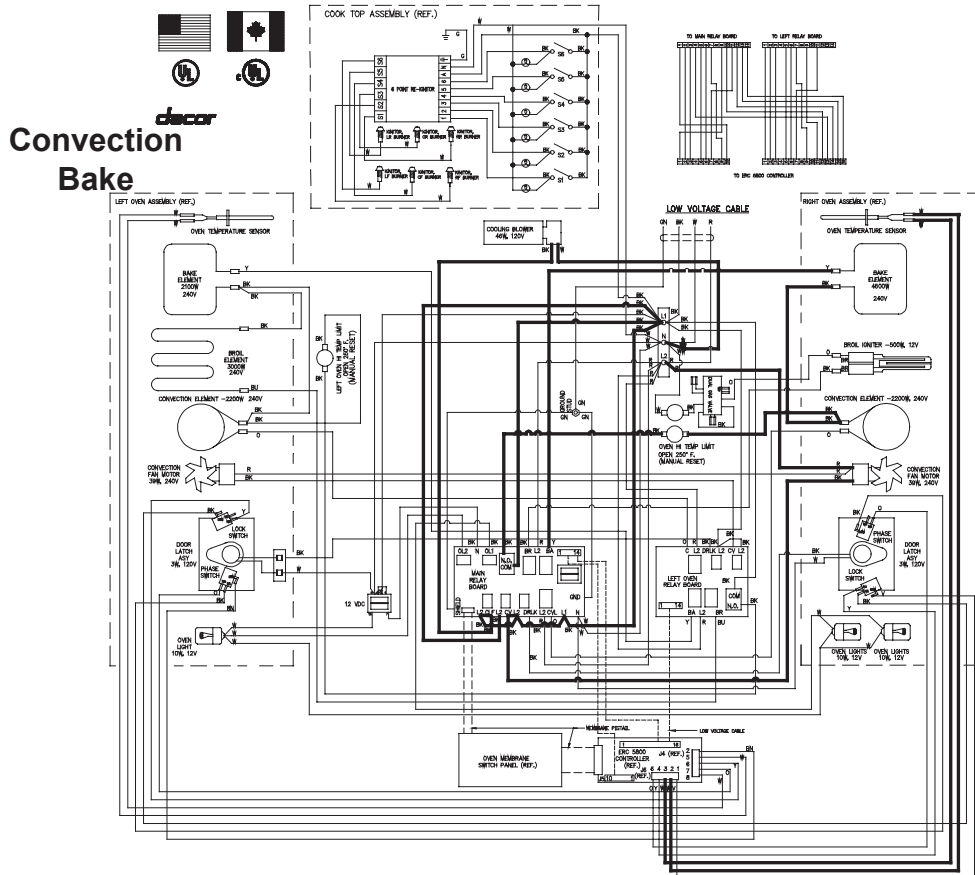

Dual Fuel Ranges

Light Circuit 36" Oven

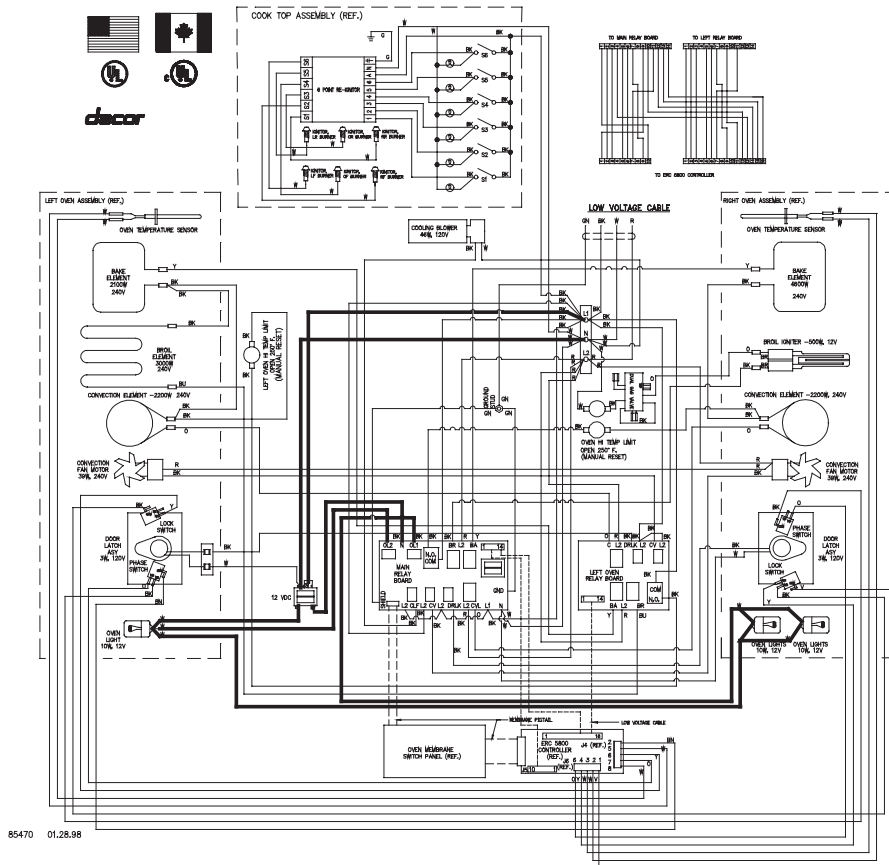

Preheat/ Bake 36" Oven

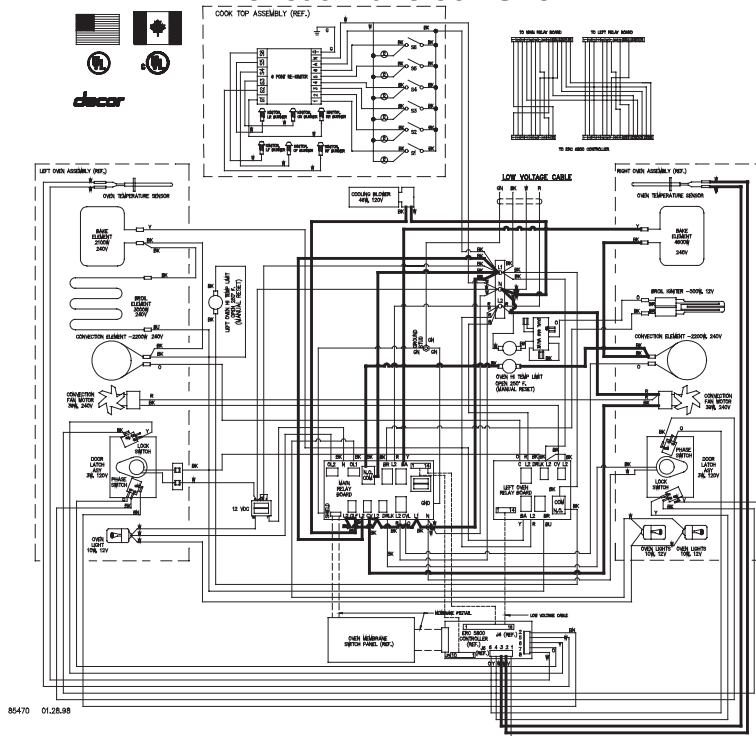

Dual Fuel Ranges

Light Circuit

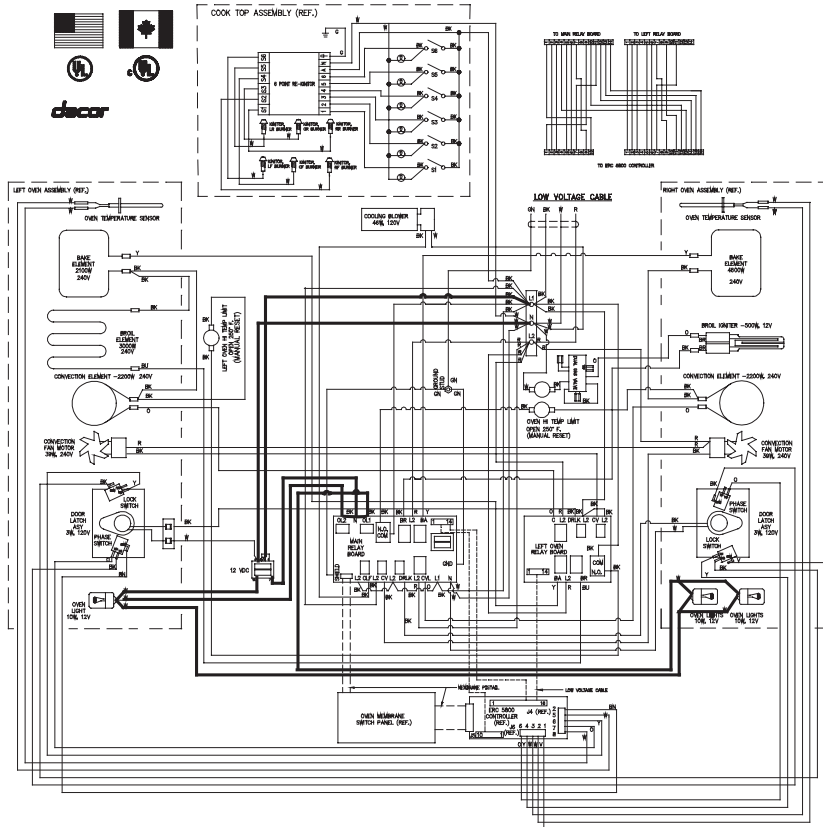

Pure Convection

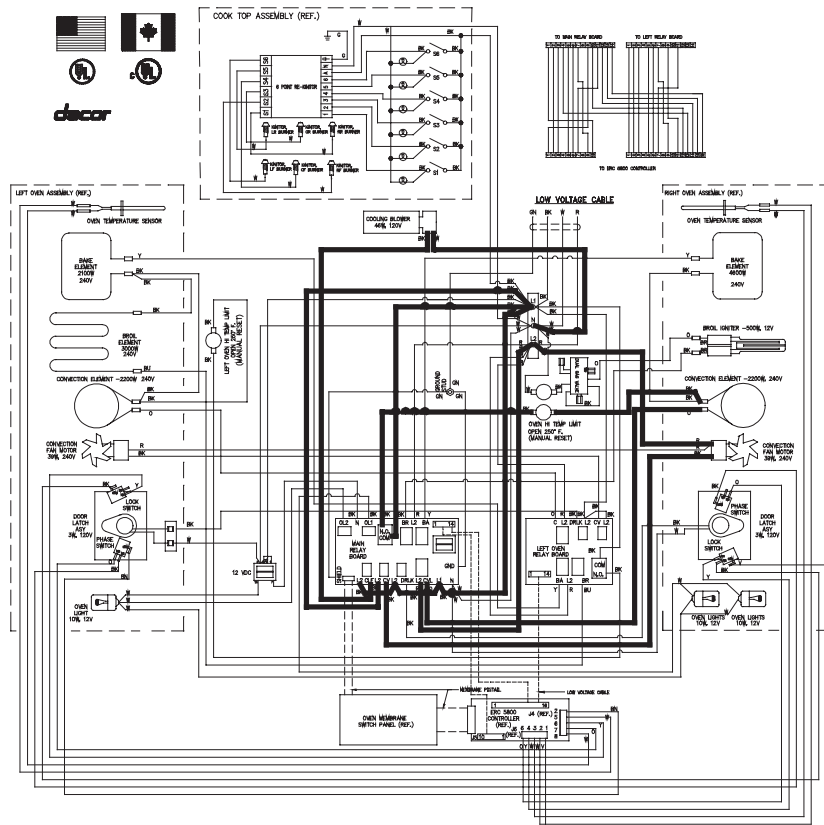

Dual Fuel Ranges

Self Clean 36" Cell

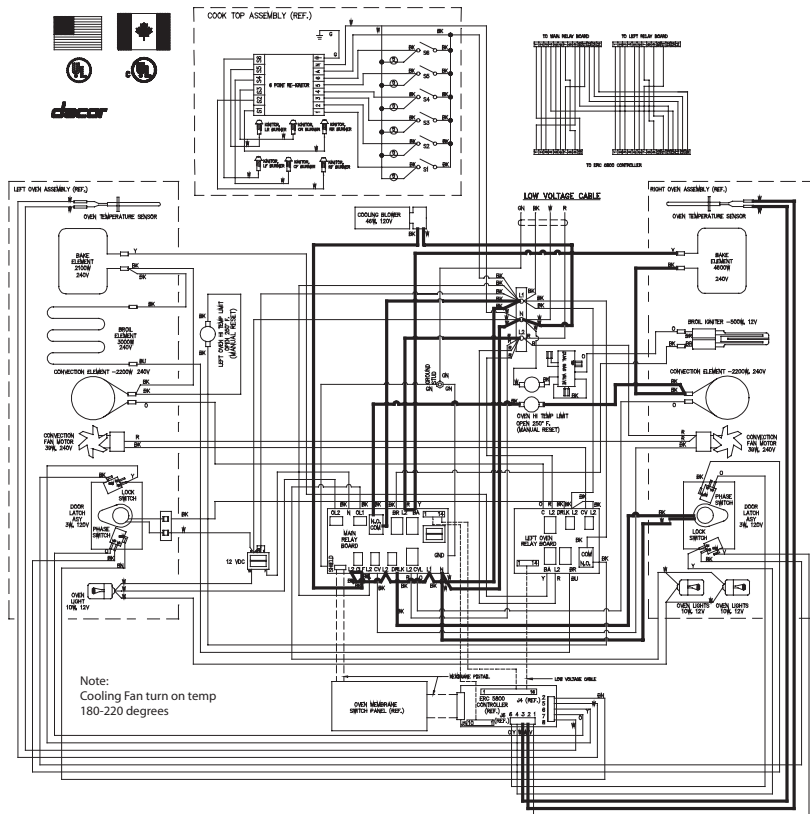

Self Clean 18" Cell

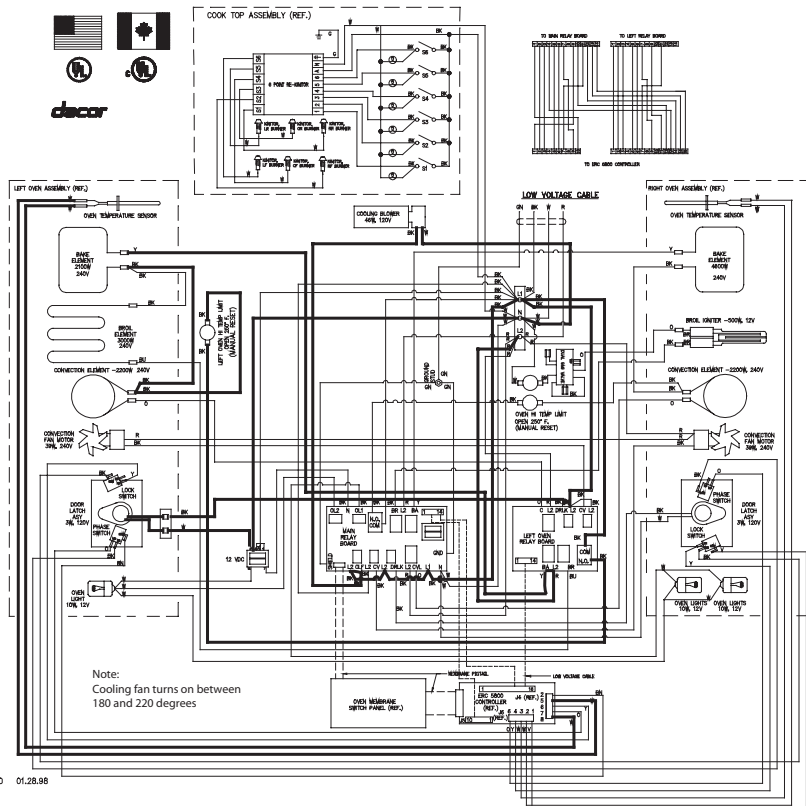

85470 01.28.98

Dual Fuel Ranges

Bake 18" Cell

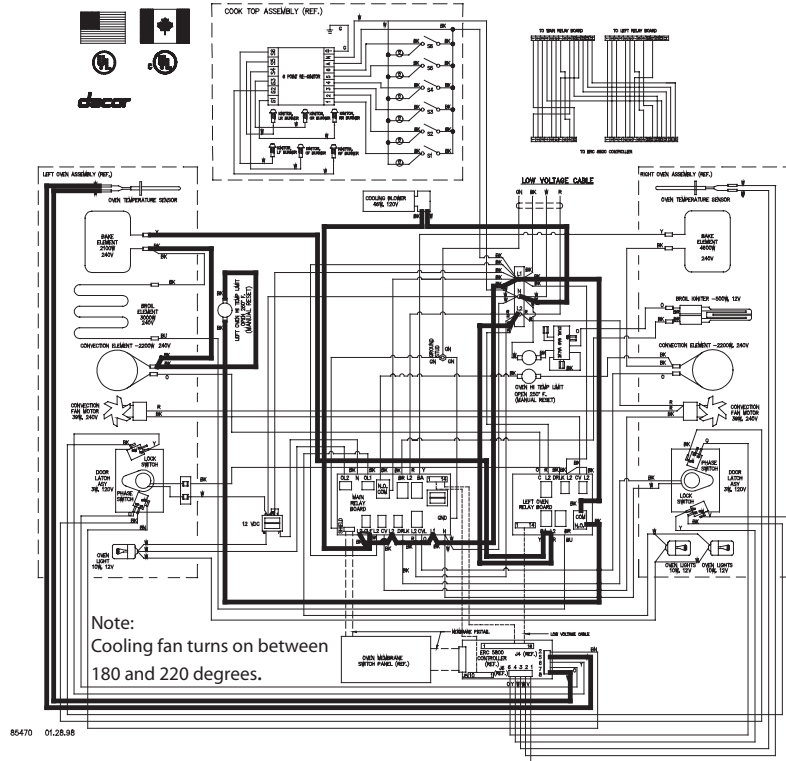

Self Clean 18" Cell

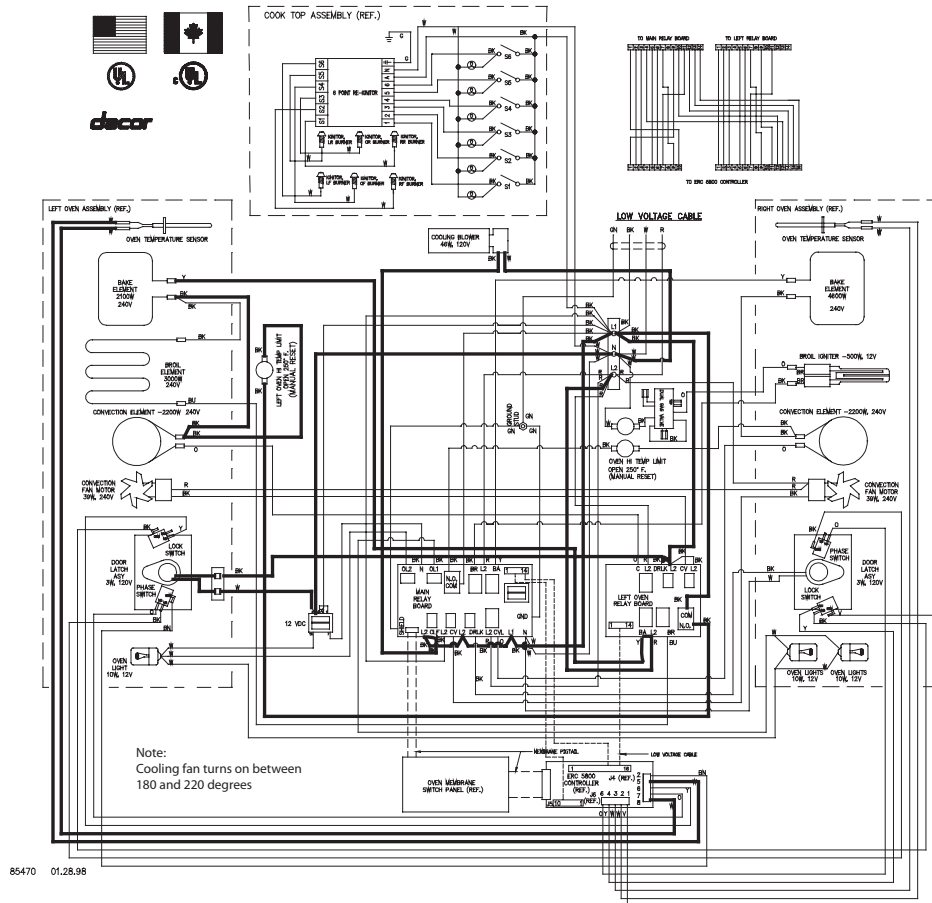

Dacor recommended cycle selections and performance tips.

We would like to take a minute to explain the performance advantage of our Standard Bake, Convection Bake and Pure Convection cycles. We hope that this information will make cycle selection easier to understand. We will also explore performance characteristics, temperature testing techniques, as well as the importance of preheat and how it effects your overall baking/roasting results.

The Fundamentals

What is convection?

Convection can be defined as air movement.

Why do convection ovens bake faster?

Dacor convection ovens bake faster because the convection fan system removes the thin layer of cool air that surrounds most refrigerated food products. Removing this layer allows the heat in the oven to efficiently penetrate the food. This speeds the cooking process.

Are convection ovens more accurate?

They can be, but most convection ovens are designed to allow multi rack baking and speed the cooking process. Thermally, many ovens actually perform worse when the convection system is applied because the air movement disturbs the natural balance inside the oven. Dacor, however, has manufactured convection ovens since 1987 and we have our systems perfectly balanced to compensate for this air movement.

All Dacor ranges and wall ovens feature the convection option.

- **Dual fuel** ranges and all **electric** wall ovens share three bake modes; Standard Bake, Convection Bake and Pure Convection.
- **Gas models** have a choice of two, Standard Bake and Convection Bake. Pure Convection adding rear heat is not an option for gas ranges.

Although we promote the use of all three bake modes, in most circumstances the Pure Convection cycle will always produce the most accurate temperatures. The following information will help you determine which cycle is best for you and your customers.

Basic terminology:

- **Baking:** refers to items baked on flat sheets or spring form pans such as cakes, cookies, pastries and other delicate items. Higher oil, butter or sugar content requires an extremely accurate oven and exact timing for the best results. Unlike roasting and braising, true baking is more exacting. Recipes have to be carefully followed and there is little room for “experimentation”.
- **Dehydrating:** uses very low temperatures of less than 150F and is designed to remove moisture slowly from fruits, vegetables and meat without actually “cooking” it.
- **Roasting:** refers to meats placed uncovered into a preheated oven and seared until done. Dense cuts of meat do not require extreme accuracy or accurate timing but this method produces an even result because the heat penetrates all sides of the meat at the same time. Beef and pork roasts, tenderloins and steaks and all types of poultry and vegetables can be roasted covered or uncovered with great results.
- **Oven Braising:** braising (simmering) is usually preferred for tougher, less expensive cuts of meat that benefit from a longer cooking period. Generally reserved for lower quality cuts, some feel braised meats, slowly cooked, offer the finest texture and are the most flavorful. Braising uses a covered pan to stop evaporation and typically involves immersing the meat, or vegetables, in wine or stock both to break down the meat and add flavor. Beef brisket, large tough roasts, short ribs and other fatty, sinewy cuts will benefit from low temperature, long term braising. The average temperature used in braising ranges from 250F to 300F. and this method can take from two to seven hours. In most cases, the lower and slower you roast - the better your results will be.
- **Searing:** Can be performed either in the oven or on the cooktop. Usually associated with applying high temperatures to the outside of meat to completely seal / caramelize the outside layer against moisture loss when cooking.

The Modes

Standard Bake - bottom heat only

We recommend selecting this mode when using a covered dish, roasting bags or when long term braising meats or vegetables. Items baked in a water bath such as cheesecakes, custards and crème brule will also benefit from this cycle without the slight disturbance of the convection system.

Convection Bake - bottom heat with convection fan

Convection Bake is used when you require a faster bake cycle or when a quick sear is desired. Because it saves time, Convection Bake is very energy efficient, saving both time and energy. Items that will benefit from Convection Bake might be, pizza, heavy casseroles, double crusted pies, breads in loaf pans etc. This mode benefits crispy or browned bottom crusts.

Pure Convection / rear heat only with convection fan

Using rear heat removes direct heat from the oven cell and is the recommended mode for multi-rack baking. When thoroughly preheated, the oven cell is the same temperature, top to bottom, side-to-side, front to back. Because the heat source is behind the food rather than underneath it or on top of it; this method allows the use of five to six racks with equal results on each rack.

For delicate foods that easily show heat trails such as single crusted pies, light colored cookies, cakes, pastries or when absolute accuracy is essential, Pure Convection is the cycle of choice. The combination of a rear heat source, convection filter system and a centrally mounted oven temperature sensor make this system a very powerful tool for crafting the perfect meal.

The Dacor Convection Filter

The removable, stainless steel convection filter is located on the face of the convection baffle. During a convection cycle, all of the air inside the cell is moved through this filter. The filter works to stop odor and flavor transfer. The filter traps particles rather than recirculating them to other foods. Keep the filter clean and clear for improved circulation. If the filter is not clean, the oven can produce hot spots. The convection filter is dishwasher safe.

The Importance of Preheat

A proper preheat can improve baking/testing results more than any other thing you can do. In most cases, when you hear the oven preheat tone, the cell has **approximately** reached the desired temperature. All high-end ovens contain a great deal of internal metal and glass and these components have to stabilize, until they do, the internal air temperatures can fluctuate wildly. The difference between a great result and an angry customer could boil down to how the customer interprets the preheat cycle.

Let us illustrate two different customers results:

Customer A has had inconsistent results and is getting ready to bake four dozen cookies. She sets the oven temperature to 325F and chooses Standard Bake or Convection Bake. While the oven is preheating, she finishes loading her baking sheets with cookie dough. When the oven tones, she opens the oven door, walks back to get her cookie sheets and places them into the oven one sheet at a time. She shuts the door and sets the timer for 18 minutes. When the timer sounds and she unloads the oven, she discovers that her cookies are all different colors and textures. Why? There are several reasons.

- The customer was comfortable with Standard Bake and did not know that another cycle would be more correct for multi-rack baking and uniform heat distribution.
- The preheat tone sounded, but the oven temperatures were not yet stabilized. There are several different “zone” temperatures in the cell.
- Opened the door and allows at least 50 to 70 degrees to escape.

Combine those three factors with a recipe calling for exact temperatures and baking times results in a situation guaranteed to ruin the most well planned recipe. Your customer will likely complain about either a combination of poor color and texture or slow bake.

Customer B normally gets good results because she understand the modes and the importance of a thorough preheat. She chooses Pure Convection, and like customer A, sets the oven for 325F and waits for the tone. When she hears the tone, however, she waits an additional few minutes. This allows the oven extra time allows the oven to stabilize and all of the zones combine, and it allows for a much quicker temperature recovery when opening the door and loading the oven. Always try to allow for a twenty-minute preheat.

Why do heavier ovens take longer to preheat?

- It comes down to heat sink mass or overall cubic feet. The heavier or larger the oven, the more material there is too preheat and the longer it takes. Higher wattage elements or larger BTU burners will not improve your overall preheat accuracy. They will only force it to heat faster. Lighter weight ovens preheat faster but once preheated they do not maintain temperature as well because of the heat loss caused by poor insulation or lightweight materials.

With sturdier items like roasts, casseroles, game meats, fowl, braised vegetables you can usually load the oven when you hear the preheat tone.

The tone will usually sound in seven to nine minutes.

Temperature Testing Procedures

** Note that all testing data is based upon controllers (ERC) that are incapable of receiving multiple adjustments. Be aware that some new controls allow you to individually adjust each bake mode. In this case, averages are unnecessary.

The Do's and Don'ts

The Don'ts

- Prior to testing, don't expect an oven with more than one bake mode to behave the same on all modes
- Don't open the door during testing
- Don't assume the homeowners \$6.00 thermometer is more accurate than your own \$200.00 digital meter
- Don't assume that the homeowner always chooses the proper cycle; in fact, don't assume the homeowner understands anything about proper cycle selection. There may not be a mechanical problem at all.

- Don't assume that your oven has stabilized at the preheat tone and start testing. Always wait twenty minutes for an accurate reading.
- If time allows don't make an adjustment to the ERC without first determining how it will effect all three bake modes
- Don't rush

The Do's

- Take your time and get it right. It is better to stay a little longer than to come back.
- If your time is short, test the most accurate cycle (Pure Convection) and make an adjustment based on that result.
- Always use a meter with at least two leads
- Always educate on the benefits of convection
- Wait at least twenty minutes prior to recording any cut in/cut out temperatures. High or low, it will take the oven two or three complete cycles before it stabilizes
- Test as long as possible. Testing less than forty minutes will not give you a chance to record enough rises.

Recommended Temperature Meter

Dacor recommends the relatively inexpensive Fluke 52 digital thermometer. This meter allows the use of two thermocouples for better accuracy,. We recommend that large alligator clips be attached to the ends of the thermocouple leads for accurate placement within the oven cell.

Why Two Thermocouple Leads?

A single lead attached to the center of the oven cell does not give you a good understanding of what is happening in other parts of the oven. A customer will often claim that the oven is hotter on one side than the other. Using two leads allows you to measure both sides of the oven cell at the same time. Measuring multiple locations also allows you to ovoid opening your oven door once testing has begun. **Once you have begun testing, you can move freely from cycle to cycle but never open the oven door.** If you do, add an extra ten minutes to your testing.

The Long And Short Of It

The longer the test, the more accurate the results will be.

Regardless of the cycle selected, forty minutes is a **minimum** test period.

You cannot do a thorough test sequence in a shorter time. If time allows, testing all three bake modes will give you the best averages. If time allows (1 1/4 hrs) the ideal test sequence should look like this.

- Carefully discuss the customer's problems to determine the problem
- Check ERC offset and record
- Install dual probes with alligator clips as specified
- Select **Standard Bake** and adjust to 350F.
- Record start and preheat tone time

- Record first cut out temp
- Record first cut in temp
- Continue to record until you have at least four to five complete rises. This will take approx thirty five to forty minutes.
- When you have recorded 4-5 rises, cancel cycle and select Convection Bake, adjust to 350F
- Continue testing Convection Bake for ten minutes. (Note that your testing times can drop because your oven is already thoroughly heated) Expect total performance change
- Record 3 rises and without opening the door, cancel the cycle and select Pure Convection
- Repeat test sequence for 3 rises and record
- Terminate test.

Following temperature evaluation, you will be able to draw an average based upon all three cycles.

If time is short we recommend that you perform your quick test as follows

- Be prepared to record your cut in and cut out temperatures. See sample graph at right.
- Determine if the ERC has already been recalibrated. Record the adjustment but do not readjust at this time.
- Chose Pure Convection and set the oven control for 350F.
- Allow the preheat tone to sound and wait ten minutes before recording temperature rises.
- **Test and record for 30 minutes.** Any less time and the oven may not have balanced.
- Following the test, compare the average cut in and cut out temperatures and from those figures determine the midpoint average.
- The average temperature will tell you whether an adjustment to the ERC is necessary. The ERC can be recalibrated plus or minus 35 degrees.

CUT IN	CUT OUT

ERC Calibration Method / All Models

- Select the Bake mode and using the temperature slew button raise display temperature above 500F.
- Quickly return and again press and hold the Bake keypad until the display changes. (Approx four seconds)
- Two red offset numbers will appear on the right side of the display. When illuminated, release the Bake keypad and using the temperature slew buttons adjust the ERC offset in five-degree increments up to 35 degrees plus or minus.
- When complete press cancel / secure.

Porcelain

Porcelain is basically glass. It is durable, easy to clean and heat resistant. Because of these qualities, it lends itself well to most oven interiors and cooktop surfaces. While durable, it is also vulnerable to impacts and most sugar-based substances. (Also, be aware that when heated, some vegetables create sugars and it does not have to be a processed sugar to damage the porcelain) When heated, sugars will permanently stain or etch most glass surfaces once they have worked their way into the fabric of the glass. A self-clean cycle will not remove them but a vinegar-based solution can often neutralize the stain. In order to be most effective:

- Select Convection Bake and preheat the oven for thirty minutes at 350F.
- Add one quart of plain white vinegar to a casserole dish and place on the center rack of the oven
- Bake for one hour
- **Without** opening the oven door, cancel the bake cycle and allow oven to stand overnight.

In many cases this will neutralize most white or ashy stains in an oven cell. The oven interior is generally considered to be a working component rather than a cosmetic component of the oven, therefore, some staining is considered normal.

Reverse Air Flow

The majority of modern wall ovens and ranges incorporate some sort of internal cooling or ventilation system. Most of these systems simply allow the oven to breath better during the bake / broil cycle. Others only turn on a fan during self-clean. Dacor incorporate a reverse airflow cooling system that is used as both an external and internal cooling system.

At temperatures above 220F. all Dacor ranges and wall ovens will automatically turn on the Reverse Airflow System. It will run throughout the bake, broil and self clean cycles. Once the internal temperatures dip below 300F the system will automatically turn off.

Dacor products draw air **in** through the door handle and from underneath and through the door. This style of “reverse” airflow allows us to maintain much lower external door, window pack and control surface temperatures as well as provide a continuous flow of cooler air across the sensitive electronic controls.

Depending on the model, once the air has circulated through the product it either exits through the lower exhaust grill or behind the product.

Adjusting The Cooling Fan Cutout Temperature

Dacor wall ovens and ranges come preset with the cooling fan cut out preset at 300f. Please note that 300f. and the indication 000 are the same.

In certain applications, (high or low ambient temps or high altitude) you may want to modify the default setting of the cooling fan cutout temperature. It can be adjusted from 450f. to 200f. To modify the setting, please perform the following sequence waiting no more than three seconds between keystrokes.

- Press broil keypad
- Press the plus temperature keypad
- Press and hold the broil keypad until the display indicates three red numbers on the right side of the display
- Once the cutout temperature is displayed use the plus or minus temperature keypads to raise or lower the setting
- Press cancel secure