

DISHWASHER and COMPACTOR

STUDY COURSE

UNDERSTANDING COMPACTOR:

- *MECHANICAL COMPONENTS*

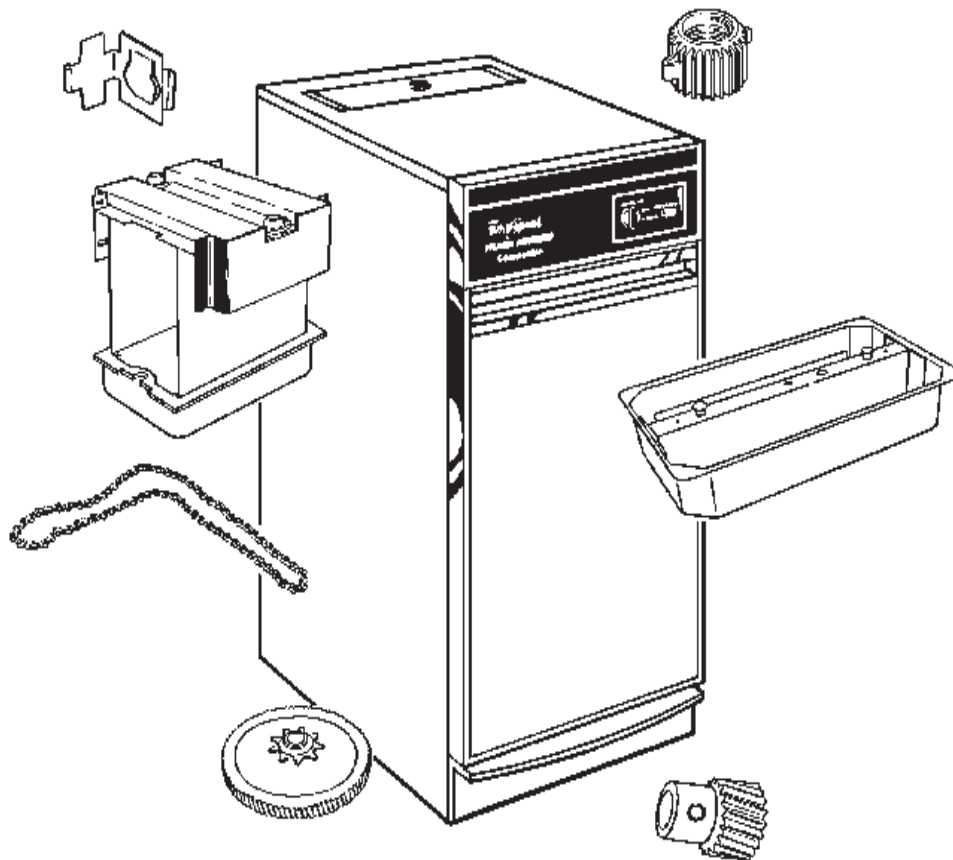

WHIRLPOOL CORPORATION does not assume any responsibility or any liability in connection with the use of this manual.

© 1990, 1998 WHIRLPOOL CORPORATION

All rights reserved. No portion of this book may be reproduced in any form without written permission from WHIRLPOOL CORPORATION.

® The trademarks WHIRLPOOL ,  Whirlpool ,  Whirlpool , and *FSP* are registered trademarks of Whirlpool Corporation.

INTRODUCTION

The material presented in this module is intended to provide you with an understanding of the fundamentals of dishwasher and trash masher® compactor servicing.

Major appliances have become more sophisticated, taking them out of the screwdriver and pliers category. Their electrical circuits include several different types of automatic controls, switches, heaters, valves, etc.. Semiconductors, solid-state controls, and other components usually associated with radio and television electronic circuits are being engineered into automatic washers, dryers, dishwashers and refrigerators.

The appliance technician is emerging into a professional status of his own. He must prepare himself now to be able to perform his duties today as well as to retain his professionalism in the future.

No longer is on-the-job training sufficient to prepare technicians for the complicated procedures required for today's sophisticated appliances. This training can best be obtained through organized classroom study and application. However, much of the knowledge necessary to service today's appliances can be obtained through study courses. Completion of this and other courses will provide you with sufficient understanding of appliances and their operation to enable you to do minor service. It will also serve as a valuable stepping stone to more advanced study and on-the-job training to improve your servicing skills.

Information contained in this module is used on WHIRLPOOL® appliances.

TABLE of CONTENTS

	PAGE
CHAPTER 1	3
MECHANICAL COMPONENTS	

***TEST** See Test Book LIT4314204

***NOTE:** *We recommend taking the TEST for MODULE 4, right after studying it.*

CHAPTER 1

MECHANICAL COMPONENTS

ACCESS TO PARTS

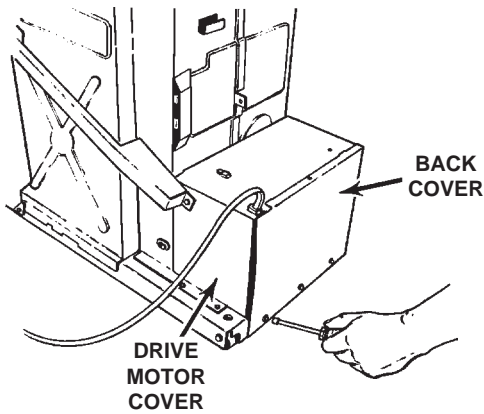

To access parts, it will be necessary on undercounter models to first remove the compactor from under the counter top. This is done by removing a screw, located on each side, going through the bracket to the underside of the top. There is another way, which by pushing down on a bracket (located in the middle, underneath the top), will release the tab on the top part of the compactor.

Remove the drawer, then the compactor can be pulled out. Remove the screws holding the back cover and motor cover to the frame. The drive motor and centrifugal switch are now exposed.

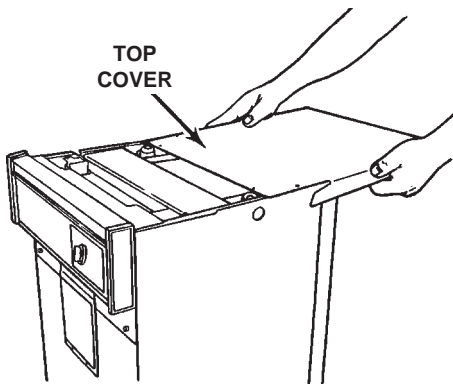

Now remove the screws holding the top cover to the frame, slide the top toward the back and lift. The power nuts, ram, and switches (top limit and directional) are exposed.

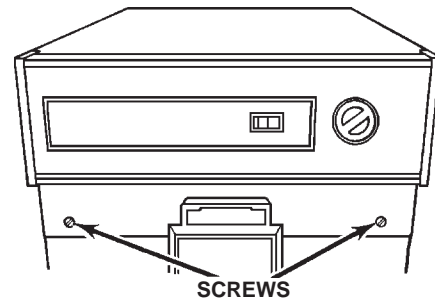

The console parts can be exposed by opening the drawer, then remove the screw on each side. Depending on the model, lift-up or push down, then pull out to remove. The rotary switch, dense pack switch, directional switch and top limit switch are now exposed.

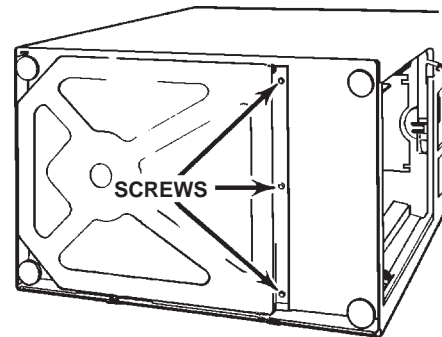

Lay the compactor on its side and remove the screws holding the bottom pan to the frame. This exposes the chain, power screws, drive gear and drawer switches (safety and tilt).

On free standing models, remove the screws holding the console, top, cabinet and bottom pan to expose the same type parts.

TYPE OF OPERATION

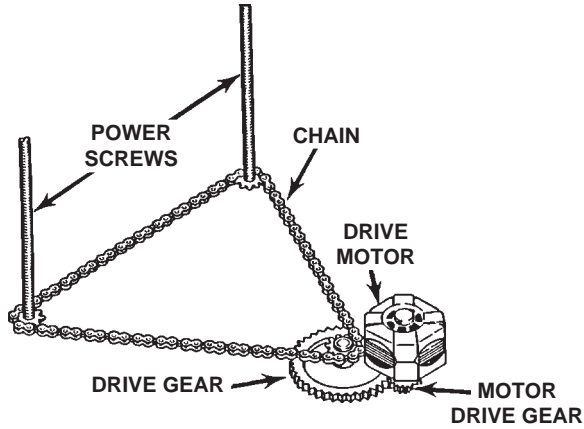

Shown above is how the ram is powered to move up and down the power screws. This type system is a direct gear-to-gear system.

DRIVE GEAR

The drive gear interlocks with the motor drive gear. A chain wraps around the sprocket on the back of this drive gear, and around the power screw sprockets.

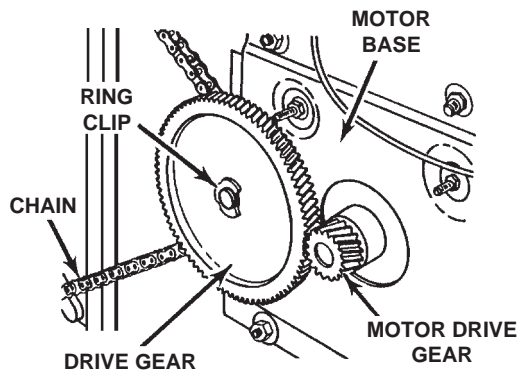

The drive gear slides over the shaft of the motor base and is held by a ring clip.

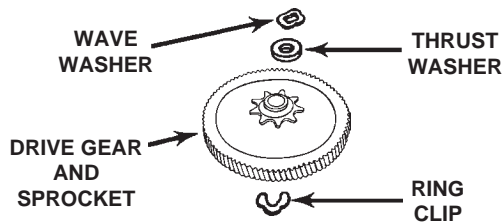

Be sure the wave washer is placed next to the base, then the thrust washer, gear and clip when reassembling.

MOTOR DRIVE GEAR

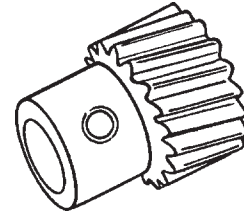

The motor drive gear (above) slides over the shaft of the drive motor and is held on with a drive pin (see below). The teeth in this gear, mesh with the teeth in the drive gear.

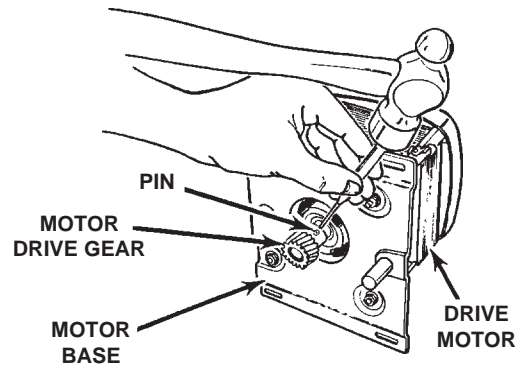

DRIVE CHAIN



The chain wraps around the sprocket of the drive gear and the sprockets of each power screw. It transfers electrical power from the drive motor to mechanical power to the power screws, causing the ram to move up or down.

RAM

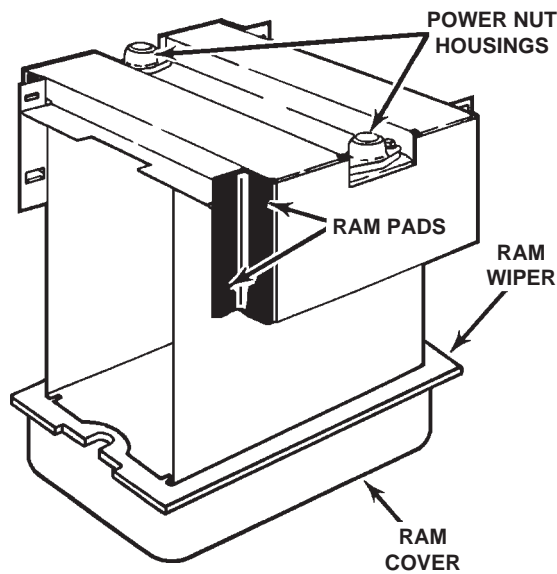

1972 thru 1992

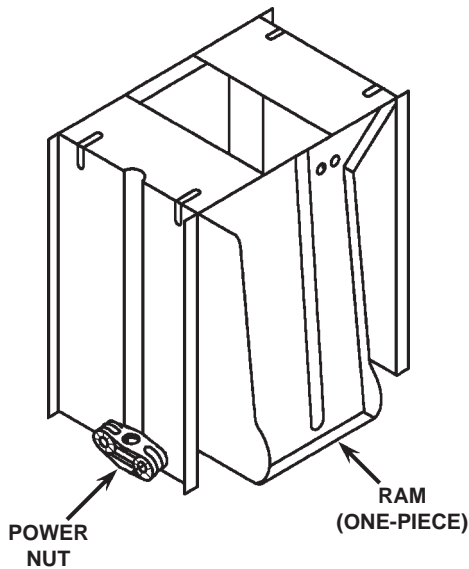

1992 to current models

The ram is located in the center of the compactor, attached to the power screws, and is used to compact the trash.

RAM WIPER

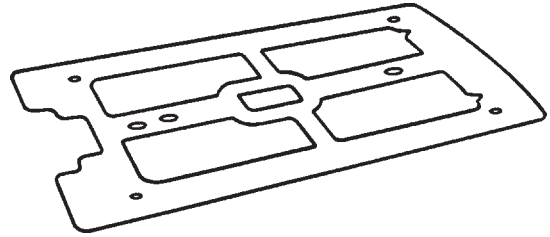

1972 thru 1992

The wiper is located between the ram and ram cover. It is the same size as the drawer and during compaction, it keeps the trash from going over the sides.

RAM COVER

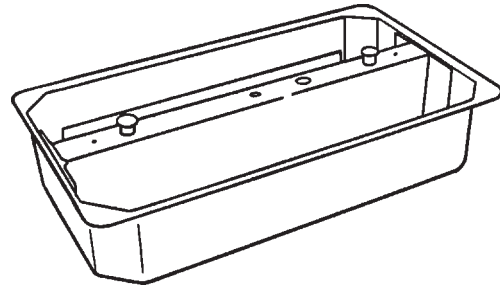

1972 thru 1992

The cover hooks to the bottom of the ram. As the ram comes down the power screws, the cover comes in contact with the trash.

RAM PADS

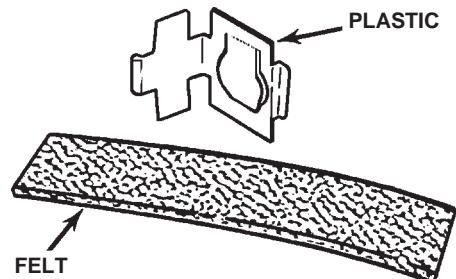

1972 thru 1992

These pads are located on the ram, in each of the eight corners. They are used to keep the ram in position as it rides up and down the power screws.

RAM SLIDES

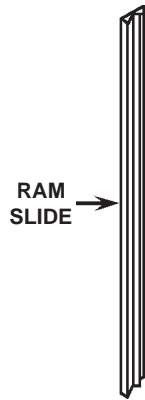

1992 to current models

These slides are located in each of the four corners. They are used to keep the ram in position as it rides up and down the power screws.

ROLLER BEARING

The roller bearings are located on both sides, under the slide frame, and helps in rolling the drawer in and out. It is threaded and held to the frame by a nut.

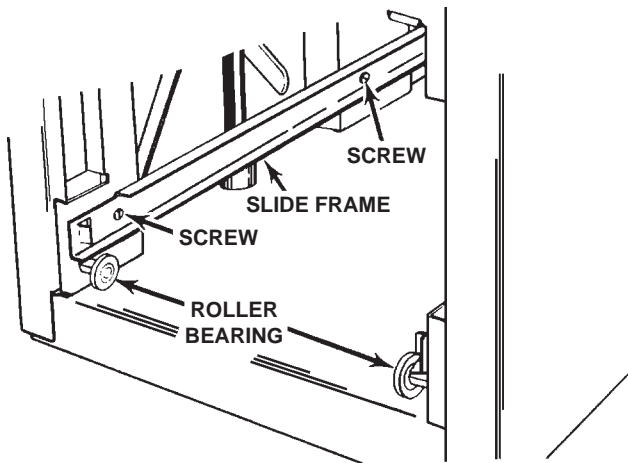

On early models, the roller bearing was riveted on the slide frame. The roller bearing could only be replaced along with the complete slide frame.

SLIDE FRAME

The slide frame (above) is located on both bottom sides, inside the drawer area. The drawer rides inside this frame. It is held to the side by screws.

POWER SCREWS

The power screws (below) are located on each side of the frame. The ram rides up and down on these screws, compacting the trash. They are held to the frame with two bolts, removal is from the bottom.

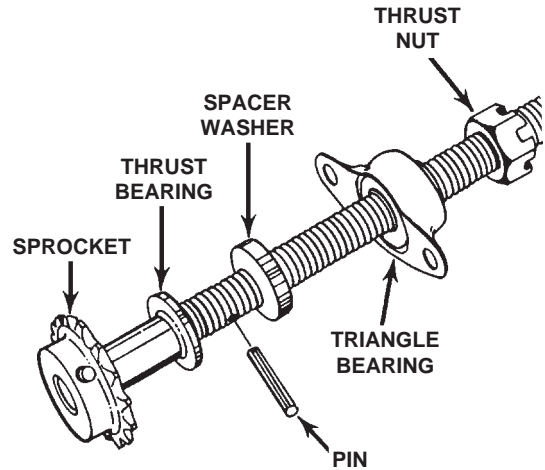

1972 thru 1981

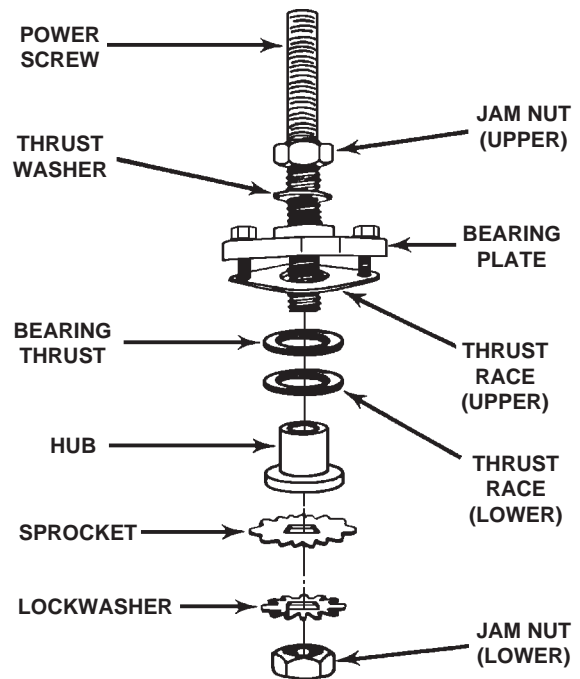

1981 thru 1992

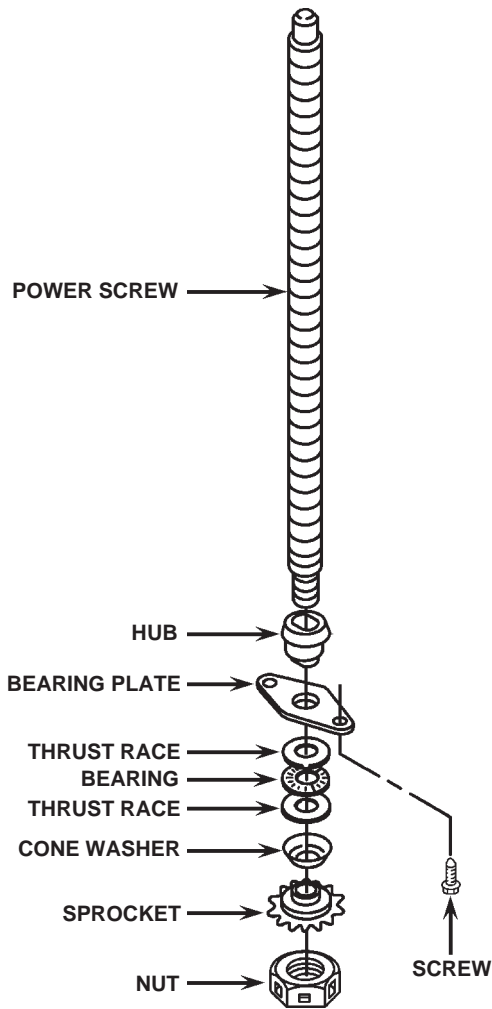

1992 to current models

After replacing, a special type grease should be used on each of the power screws. Just wipe this grease on the entire length of the threads.

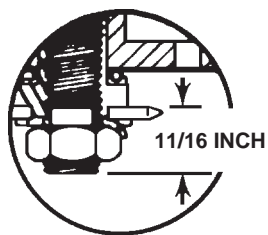

When reassembling, adjust the power screw hub so that the upper surface of the sprocket, when installed, will measure 11/16 inch from the lower end of the power screw. Tighten the upper jam nut.

POWER NUT and HOUSING

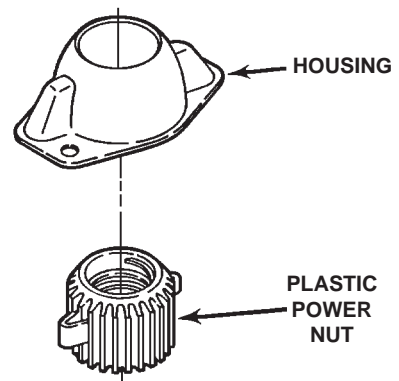
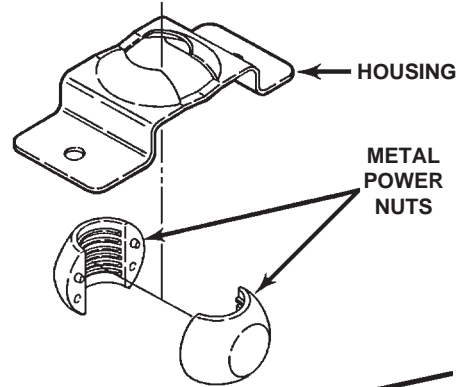

1972 thru 1992

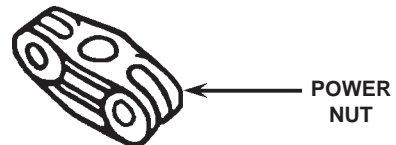

1992 to current models

The power nuts (1972 thru 1992) are located on the top of the ram (both sides) and held by a housing and two screws. Earlier models used metal power nuts which split into two pieces. Later models used a plastic one-piece power nut and the tabs **MUST** be facing up when replacing.

The power nuts (1992 to current models) are mounted on the lower sides of the ram. The power screws thread into these power nuts.

After replacing, a special type grease should be used. Just pack some of this grease into the top of the nuts.

DO NOT remove both power nuts at the same time. The ram will fall to the bottom.

SPRAY DEODORANT

This spray deodorant, if used, helps control odors that might develop in the trash while in the compactor.

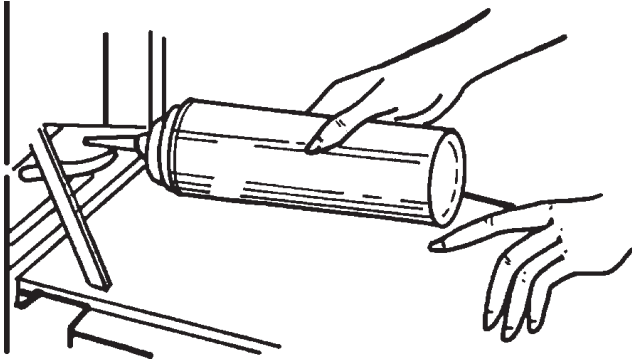

Open the drawer and insert the spray nozzle into the plastic holder. Push the can forward until it snaps into place.

A special metering device is built into each can of Whirlpool Compactor Spray Deodorant. Each time the drawer is closed, the can releases two metered sprays onto the load of trash. A can of spray should last three to five months, depending on usage. Certain models will use a solid deodorant such as Fresh-N-Air or Airwick. It will sit in the deodorant compartment.

SPECIAL TIPS

- Trash material starts being compacted when the drawer is about one-third full. Do not be concerned if the trash material is not compressed after the first two or three cycles. Remember, the ram does not travel all the way to the bottom of the drawer.

- When garbage is added along with trash, the user should open and close the drawer two or three times to spray the waste.

- When glass bottles are added, lay them flat in the drawer. DO NOT stand them upright. Bottles will usually break during compacting. This is normal, so don't be alarmed by the sound made as they break. When glass is part of the trash load, use care removing and carrying the bag so you don't cut yourself.

- If liquid grease or fat is part of a trash load, some staining of the paper bag can be expected. Also, small tears in the bag will occur when bottles and cans are compacted. This is normal and in no way affects the performance of the compactor.

- To help keep the ram cover clean, certain kinds of garbage should be wrapped in newspaper or covered with two or three thicknesses of paper toweling before being compacted. Examples are soft items such as gravy, sauces, puddings, whipped cream, fruit, etc.

- There are a few items we do not recommend compacting, because of the possible odor that can result when stored at room temperature. They are: the trimmings from cleaning fish or poultry and grapefruit rinds.

- IMPORTANT:** DO NOT compact the following items: oily rags, paint filled rags, and other flammable items which are subject to spontaneous combustion (they can create a fire hazard), or personal hygiene items. Aerosol cans because they may contain explosive or highly toxic chemicals such as strong insecticides or poisons.

BLANK

BLANK