

Service Manual

for
Thermador
Built-In Ovens

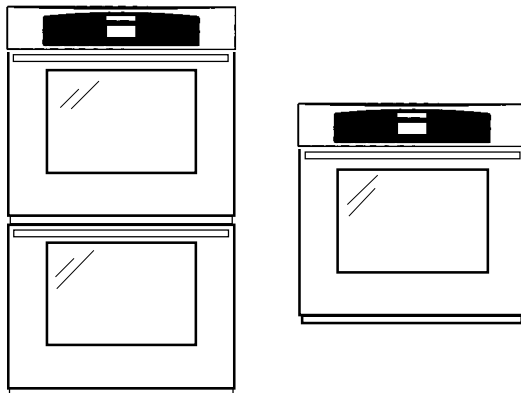

Models:
C302/C272
C301/C271

Thermador[®]
C O R P O R A T I O N

Table of Contents

Introduction	1	Troubleshooting	48
Relay Boards	2	Testing the Components	48
DAC Relay Board	3, 6-8	The Convection Fan Motor	49
Wire Harnesses	4-5	The Lamp Transformer	49
DAC Relay Board Troubleshooting Chart	9-10	The Oven Door Latch Assembly	50
Control Panel	11	The Hidden Bake Element	51
Electronic Oven Controls	12	The Broil Element	51
Control Panel Assembly	13	The Convection	52
Glass Touch Panel	14	Bake Element	52
Display Head	15	The Hi-Temp Cutout	52
Display Head Troubleshooting Charts	16	Fault Codes	53
Serial Number/Data Sticker Location	17	"C" Oven Current Flow Charts	54
Symbols You Will See in the Manual	18	Oven Mode Time Charts	55
Thermador® Warranty	19	Bake Mode Sequence of Events Chart	56
		Bake Pre-Heat	57
		Bake Mode	58
		Proof Sequence of Events Chart	59
		Proof Pre-Heat	60
		Proof Mode	60
		Roast Sequence of Events Chart	61
		Roast Pre-Heat Mode	62
		Roast Mode	63
		Broil Sequence of Events Chart	64
		Broil Pre-Heat	65
		Broil Mode	65
		Convection Sequence of Events Chart	66
		Convection Pre-Heat Mode	67
		Convection Mode	67
		Dehydrate Sequence of Events Chart	68
		Dehydrate Pre-Heat	69
		Dehydrate Mode	69
		Convection Bake Sequence of Events Chart	70
		Convection Bake Pre-Heat Mode	71
		Convection Bake Mode	72
		Convection Roast Sequence of Events Chart ...	74
		Convection Roast Pre-Heat Mode	74
		Convection Roast Mode	75
		Convection Broil Sequence of Events Chart	76
		Convection Broil Pre-Heat Mode	77
		Convection Broil Mode	77
		Clean Mode Sequence of Events Chart	78
		Clean Pre-Heat Mode	79
		Clean Mode	80
		"C" Oven Halogen Light Circuit	81
		Schematic Drawings and Wiring Diagrams	
Servicing The Components	20		
Oven Component Locations	20		
Removing the Bake and Broil Elements,	21		
Catalyst and Meat Probe Jack	21		
Removing the Hidden Bake Element	23		
Removing the Oven Temperature Sensor	25		
Removing the Convection Bake Element	26		
Removing a Convection Fan Motor	27		
Removing a Halogen Lamp Holder	29		
Removing the Control Panel	31		
Removing the Glass and Display Head	33		
Removing the Oven Light Switch, the Oven Door Latch Assembly, and The Hi-Temp Cutout	35		
Removing the Blower, Double Line Break Relay, Lamp Transformer and Relay Board	37		
Removing the Air Switches	39		
Removing a Blower	41		
Removing the Lamp Transformer and the Double Line Break Relay	43		
Removing an Oven Door	44		
Removing the Oven Door Gasket	45		
Removing the Oven Door Components	46		
Removing the "C" Oven Module	47		

“C” Oven Service Manual

Introduction

This manual contains information that is necessary for servicing the Thermador® Built-in electric ovens,

Models C271, C272, C301, C302

This manual is designed to be used only by qualified service personnel. Thermador recommends that customers do not service their own ovens, due to the complexity and the risk of high-voltage electrical shock.

The information is organized to help the service easily find what is needed to repair the unit.

The C Oven is very similar to the S Oven. The noticeable differences between the S and C Ovens are Aesthetic, DAC Controls, Single Relay Board, Curved Control Panel, Curved Door Glass, Upper Oven Meat Probe in C Oven, Hidden Bake Element in C Oven.

“C” Oven Relay Boards

RELAY BOARD MATRIX

REPLAY	FUNCTION
K0	Upper Oven Latch Motor
K1	Lower Oven Latch Motor
K2	None
K3	None
K4	Upper Oven Cooling Motor
K5	Lower Oven Cooling Motor
K6	Upper Oven Halogen TX
K7	Lower Oven Halogen TX
K8	Upper Oven Bake Element
K9	Upper Oven Broil Element
K10	Upper Oven Convection Element
K11	Upper Oven Convection Motor
K12	Lower Oven Bake Element
K13	Lower Oven Broil Element
K14	Lower Oven Convection Element
K15	Lower Oven Convection Motor

“C” DAC RELAY BOARD

(Digital Appliance Controls)

There are 2 relay boards, 1 for a single oven and 1 for a double oven. You can use the double oven board for a single oven. You must use a double oven board for a double oven.

The relay board has 14 snap relays activated by 24 volts d.c., 8 small pin headers that carry *signal voltage* to components, and 5 large pin headers that provide or transfer 120 volts ac to components.

Relays K1 through K15:

- K0 Transfers 120 volts from l2 to upper oven latch motor.
- K1 Transfers 120 volts from l2 to lower oven latch motor.
- K2 None
- K3 None
- K4 Transfers 120volts from 12to both oven cooling motors.
- K5 Transfers 120 volts from 12 to both oven cooling motors.
- K6 Transfers current to complete 12 v.a.c. Upper oven halogen light circuit.
- K7 Transfers current to complete 12 v.a.c. Lower oven halogen light circuit.
- K8 Transfers 120 volts from 12 to upper oven bake element.
- K9 Transfers 120 volts from 12 to upper oven broil element.
- K10 Transfers 120 volts from 12 to upper oven convection element.
- K11 Transfers 120 volts from 12 to upper oven convection motor.
- K12 Transfers 120 volts from 12 to lower oven bake element
- K13 Transfers 120 volts from 12 to lower oven broil element.
- K14 Transfers 120 volts from 12 to lower oven convection element.
- K15 Transfers 120 volts from 12 to lower oven convection motor.

These relays have normally open contacts that transfer voltage when the are snapped closed. These relays have a coil that is snapped closed by 24 v.d.c. From the eeprom (memory chip) on the relay board.

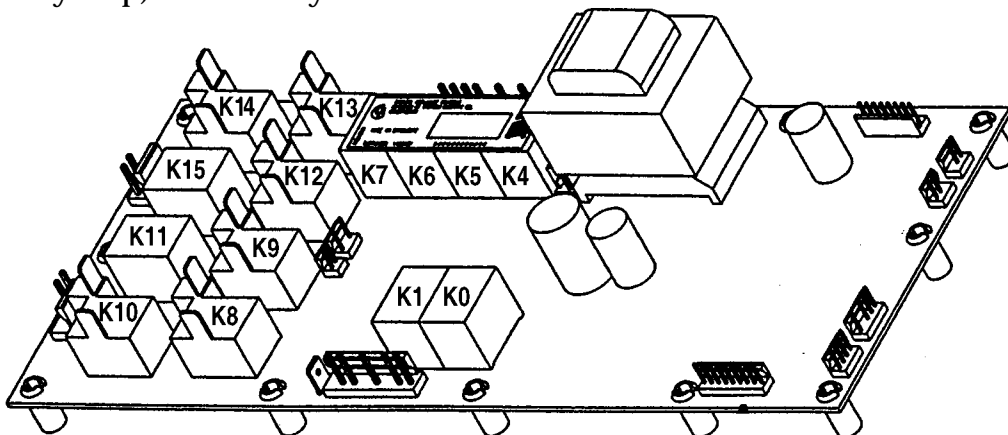

Explanation of the Wire Harness



The wire harness is shown in the illustration above.

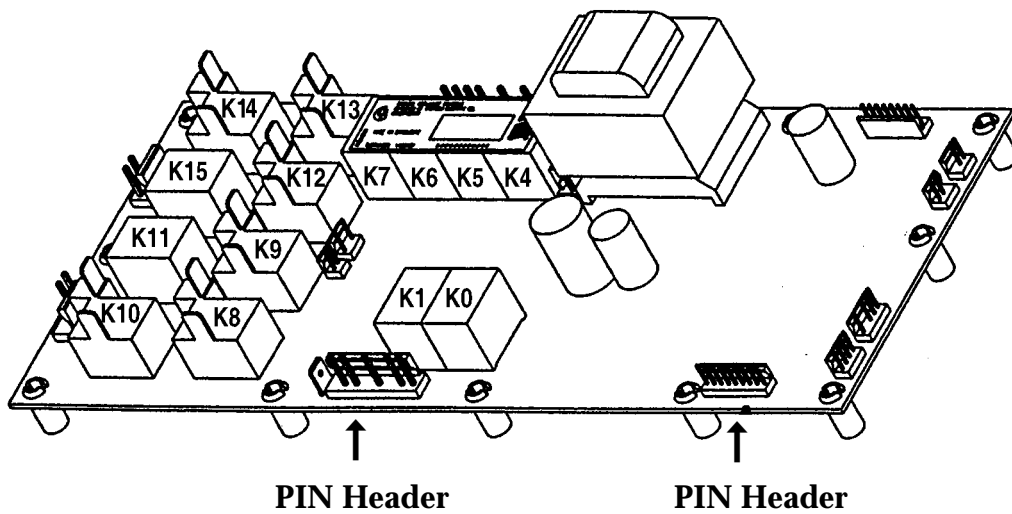

The wire harness' slide onto the pin headers of the relay board, display head, and touch control boards. The illustration above shows the pin headers on the relay board.

Wire Harnesses

(Continued)

The “C” oven uses 5 wire harnesses to transfer signal voltage between the DAC control (relay board), display head, and touch control boards (glued on the glass). The 5 wire harness' connect to the corresponding pin headers on the corresponding components (relay board, display head, touch control board). These 5 wire harness' are identified as follows:

2 Wire White Power Harness:

This wire harness has 2 wires and connects from pin header P8 on the display head to pin header P2 1 on the left touch control board. The center hole of the connector is plugged so it cannot be mis-wired. This harness sends 24 volts AC. To the touch control boards.

7 Wire White Bridge Harness:

This 7 wire harness connects from pin header P2 on the left side TCB to pin header P2 on the right side tcb. The #2 hole on the connector housing is plugged (there is no wire). This harness sends commands between the left tcb and the right tcb.

8 Wire Yellow Display Harness:

This 8 wire yellow harness connects from pin header P10 on the display head to pin header P10 on the relay board (right rear corner of relay board). This harness sends display signals from the relay board back to the display head.

9 Wire Orange Communication Harness:

This 9 wire harness connects from pin header P11 on the display head to pin header P11 on the relay board (right front corner of board). This harness sends communication signals from the display head to the relay board.

18 Pin White Communication Harness:

This split wire harness has 18 wires and connects from pin header P1 on the large left side tcb to pin header P1 on the display head. The side with the single connector goes to the display head; the side with the split (2) connector housings goes to the left side TCB. This harness sends communication from both the left and right TCBs to the display head.

DAC RELAY BOARD

(continued)

The relay board has 8 small pin headers. They are identified as P2, P3, P5, P9, P10, P11, P14, P15. These small pin headers carry signal voltage to specific components. The pin numbers are identified on the schematic. The illustration below shows that the arrow will always point to Pin#1.

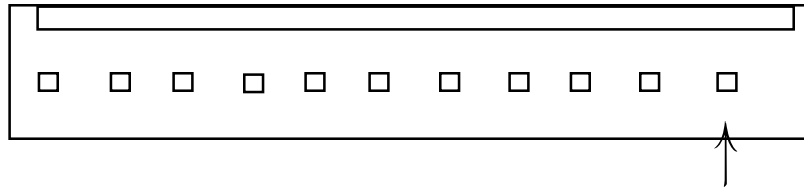

8 Small Pin Header Identification:

- P2 Sends current to the lower oven sensor. It is a 3 pin header only #1 and #2 are used. #3 is missing on the pin header and #3 is plugged on the harness so it cannot be miswired.
- P3 Sends current to the upper oven sensor. It is a 3 pin header. only #2 and #3 are used. #1 is missing on the pin header and #1 is plugged on the harness so it cannot be miswired.
- P5 Sends current to the lower oven latch switches. It is a 5 pin header. Only #1,2,3 and 5 are used. #4 is missing on the pin header and is plugged on the harness to prevent miswiring.
- P9 Sends current to the upper oven latch switches. It is a 4 pin header. All 4 pins are used.
- P10 Sends current to p10 header on the display head. It is an 8 pin header. All 8 pins are used.
- P11 Sends current to Pl 1 header on the display head. It is a 9 pin header. All 9 pins are used.
- P14 Sends current to the upper oven double line break relay coil. it is a 2 pin header. Both pins are used.
- P15 Sends current to the lower oven double line break relay coil. it is a 3 pin header. Only #1 and #3 are used. #2 is missing on the pin header and is plugged on the harness to prevent miswiring.

DAC RELAY BOARD

(continued)

The relay board has 5 large pin headers. They are identified as P0, P1, P7, P8, P18. These large pin headers carry current to specific components. The pin numbers are identified on the schematic.

P0 large pin header has 8 pins and are identified as follows;

- P0-1 Receives 120VAC from l2.
- P0-2 Sends 120VAC to upper oven latch motor
- P0-3 Blank
- P0-4 Sends 120VAC to lower oven latch motor
- P0-5 Blank
- P0-6 Not used
- P0-7 Not used
- P0-8 Blank

P1 large pin header has 8 pins and are identified as follows;

- P1-1 Receives current from center tap of halogen light transformer.
- P1-2 Sends current to lower oven halogen lights.
- P1-3 Receives current from center tap of halogen light transformer.
- P1-4 Sends current to upper oven halogen lights.
- P1-5 Blank
- P1-6 Sends current to both cooling motors
- P1-7 Blank
- P1-8 Sends current to both cooling motors.

DAC RELAY BOARD

(continued)

P7 large pin header has 4 pins and are identified as follows;

P7-1 Blank

P7-2 Blank

P7-3 Current from L2 to K11 relay

P7-4 Current to upper oven convection motor

P8 large pin header has 4 pins and are identified as follows;

P8-1 Current from L2 to K15 relay.

P8-2 Current to lower oven convection motor.

P8-3 Blank

P8-4 Blank

P18 large pin header has 6 pins and are identified as follows;

P18-1 Current from L1 to relay board transformer.

P18-2 Blank

P18-3 Neutral from "n" to relay board transformer.

P18-4 Not used

P18-5 Blank

P18-6 Chassis ground

Troubleshooting chart for relay board header pin failures

Wire harness off at pin header; or circuits open:

P2 Lower oven sensor:

Control functions normal. When sensor opens, f-61 code will appear. If sensor shorts, f-60 will appear. Cooling fan is on constantly.

P3 Upper oven sensor:

Controls function normal. When sensor opens, f-31 code will appear. If sensor shorts, f-30 will appear. Cooling fan is on constantly.

P5 Lower oven door latch:

Will accept all modes except self clean. When set in self clean, "DOR" will flash and self clean will erase.

P9 Upper oven door latch:

Will accept all modes except self clean. When set in self clean, "dor" will flash and self clean will erase

P10 Sends display signals to display head:

Glass control panel is completely dead. No display, circuit
Must be reset at breaker.

P11 Sends communication signals to display head:

Glass control panel is completely dead. No display, circuit must be
reset at breaker.

P0 Upper/lower door latch motors:

No fail code, will accept all modes except self clean. When either oven is set to self clean, the display will be on constantly, doors will not lock. It will not go into self clean.

P18 Relay board transformer:

No fail code, no display at all. Board is dead.

P1 Both cooling motors and halogen lights:

Will accept modes. In about 45 seconds F-34 will appear in the upper oven or F-64 will appear in the lower oven because the

Coolingmotors did not come on to close the air switches and signal the board. Additionally, the halogen lights in both ovens will not work. All relays will close but the lights and motors will not work.

P8 Lower oven convection motor:

No fail code. The lower oven convection motor will not work. The relay will snap closed.

P7 Upper oven convection motor:

No fail code. The upper oven convection motor will not work. The relay will snap closed.

P14 Upper oven double line break relay coil:

No fail code. If double line break relay does not close, l1 (120 volts) will not reach upper oven bake, broil, convection elements.

P15 Lower oven double line break relay coil:

No fail code. If double line break relay does not close, l1 (120 volts) will not reach upper oven bake, broil, convection elements.

“C” OVEN CONTROL PANEL

- **Touch Control Glass**
- **Touch Control Boards**
- **Display Head**

ELECTRONIC OVEN CONTROLS

HANDLING THE BOARDS

The Touch Control Board and the Display Head are subject to failure if static electricity is transferred to the components during handling. When handling these parts, use a grounding strap, if available. If not, touch any grounded metal surface, (e.g. the appliance chassis), prior to handling these components.

The replacement Touch Control Board and the Display Head are packaged in antistatic bags. When removing the boards from their bags, handle them as follows:

Touch Control Board

Handle the Touch Control Board only by the edges of the glass and the plastic frame. **DO NOT TOUCH** the connector pins, or the microprocessor chips.

Display Head

Handle the Display Head only by the edges of the plastic frame. **DO NOT TOUCH** the connector pins, the microprocessor chip, or jumper wires.

IMPORTANT NOTE: Repack the old boards in the antistatic bags before returning them to a parts distributor.

Control Panel Assembly

The control panel assembly is comprised of the following parts;

Control panel:

There are a total of 9 control panels. 3 black, 3 white and 3 stainless. The control panels are what determines the color of the unit.

Curved glass touch panel:

There are 2 glass touch panels. One is for the single oven, the other is for the double oven. Both are black in color and both are the same size. The difference between a 27" oven and a 30" oven is determined by the control panel.

Mounting brackets:

There are 6 mounting brackets that hold the glass against the control panel snug. 2 of these brackets mount the display head to the back plate.

Back plate:

The back plate is used to put pressure against the glass and hold it in place. The back plate also serves to mount the display head.

Wire harnesses:

There are a total of 5 wire harnesses on the control panel. There is 1 orange harness, 1 yellow harness, and 3 white harness'.

Display head:

There are 2 display heads; one for the single oven, one for the double oven.

Glass touch panel

The glass touch panel is comprised of a piece of curved glass with 2 control boards glued onto it.

Left side touch control board:

The large touch control board is glued on the left side of the curved glass. The large touch control board controls the following 12 modes;

Probe	Convection	Bake	Upper/Lower
Self Clean	Broil	Roast	Upper/Off
Proof/Dehydrate	Stop Time	Cook Time	Lower/Off

This control board has 3 pin headers and are identified as p1, p2, p3.

P1 pin header has 21 pins (only 20 are used, #2 is missing) and connects to the display head using 2 harness'. One harness has 18 wires, one harness has 2 wires.

P2 pin header has 8 pins (only 7 are used, #2 is missing) and connects to the small right side touch control board.

P3 pin header on the large left side touch control board is not used.

Right side touch control board:

The small touch control board is glued on the right side of the curved glass and controls the following 7 modes;

1	2	3	Light	Panel Lock	Clock
4	5	6	Timer1	Timer off	Timer2
7	8	9			
Start	0				

This control board has 1 pin header and is identified as P2.

P2 pin header has 8 pins (only 7 are used, #2 is missing), and connects to the large left side control board.

Display Head

The display head has a total of 8 pin headers (Only 7 are used), they are identified as P1, P2, P4, P6, P8, P10 and P11.

P1 pin header has 18 pins and connects to the large touch control board (P1).

P2 pin header has 2 pins and connects to the meat probe.

P4 pin header has 2 pins and connects to the lower oven air switch.

P6 pin header has 2 pins and connects to the upper oven air switch.

P8 pin header has 2 pins and connects to the large touch control board (P1).

P10 pin header has 8 pins and connects to the relay board (yellow harness to P10 on relay board).

P11 pin header has 9 pins and connects to the relay board (orange harness to P11 on relay board).

Troubleshooting chart for display head pin header failures

Wire harness off at pin header or open circuits

P10 Accepts display signals from relay board:

Glass control panel is completely dead. No display, circuit must be reset.

P11 Accepts communication signals from relay board:

Glass control panel is completely dead. No display, circuit must be reset.

P2 Upper oven meat probe:

No probe display when probe is inserted. Wont accept program. If probe is shorted, the probe display will be on constantly and the unit will accept no programs at all.

P6 Upper oven air switch:

F-34 will appear if upper oven air switch does not close. If air switch does not close the mode is cancelled after about 45 seconds.

P4 Lower oven air switch:

F64 will appear if lower oven air switch does not close. If air switch does not close the mode is cancelled after about 45 seconds.

P8 Power supply to touch control board:

No fail code, time of day on clock, control panel is dead, no reaction.

P1 Display/communication signals to tcb:

No fail code. Time of day on clock, control panel is dead, no reaction.

Troubleshooting chart for right side touch control board header pin failures

Wire harness off at pin header or circuits open:

P2 Sends commands to display head:

No fail code. Will not send commands from right side of tcb to display head. Such as numbers 0 through 9 and "start".

GENERAL

SERIAL NUMBER/DATA STICKER LOCATION

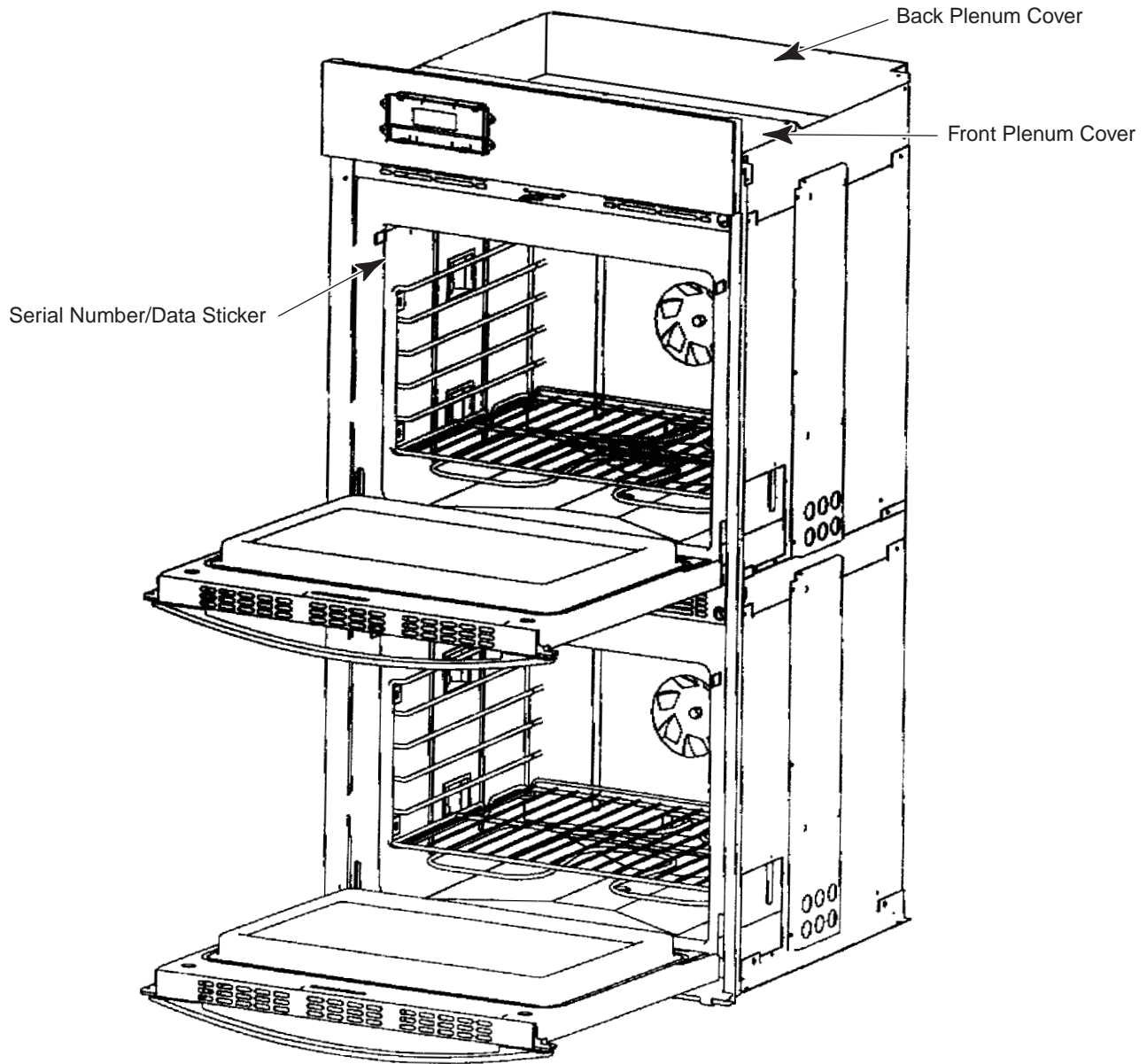

NOTE: The front plenum cover is mounted with 5 screws and the rear plenum cover with 6 screws. The front plenum cover is not mounted the same on the 27" oven as on the 30" oven.

SYMBOLS YOU WILL SEE IN THE MANUAL

The following symbols are provided throughout this manual. For reasons of personal safety and

proper operation and servicing of the oven, follow the instructions carefully each time you see one of the symbols.

WARNING

This symbol alerts you to such dangers as personal injury, burns, fire, and electrical shock.

CAUTION

This symbol alerts you to actions that could cause product damage (scratches, dents, etc.), and damage to your personal property.

WARNING

Be sure to turn off all electrical supplies to the oven before servicing; otherwise, a fire may result causing property damage, personal injury, or death.

TECH TIP!!

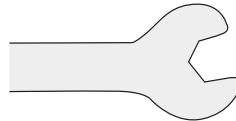

This symbol alerts you to a service tip or a special procedure.

THERMADOR ASSUMES NO RESPONSIBILITY FOR ANY REPAIRS MADE ON OUR PRODUCTS BY ANYONE OTHER THAN AUTHORIZED THERMADOR SERVICE TECHNICIANS.

THERMADOR® WARRANTY

Length of Warranty	Thermador will pay for:	Thermador will not pay for:
<p>FULL ONE YEAR WARRANTY Covers one year from date of installation. Save all dated receipts or other evidence of the original purchase date.</p>	<p>All repair labor and replacement parts found to be defective due to materials and workmanship. Service must be provided by a Factory Authorized Service Agency, during normal working hours.</p>	<ol style="list-style-type: none"> 1. Service by an unauthorized agency. Damage or repairs by an unauthorized agency or use of unauthorized parts. 2. Service visits to: <ul style="list-style-type: none"> • Teach you how to use the appliance. • Correct the installation. You are responsible for providing electrical wiring and other connecting facilities. • Reset circuit breakers or replace home fuses. 3. Damage caused from accident, abuse, alteration, misuse, incorrect installation or installation not in accordance with local codes. 4. Repairs due to other than normal home use.

This warranty applies to appliances used in residential applications; it does not cover their use in commercial situations. This warranty is for products purchased and retained in the 50 states of the U.S.A., the District of Columbia, and Canada. The warranty applies even if you should move during the warranty period. Should the appliance be sold by the original purchaser during the warranty period, the new owner continues to be protected until the expiration of the original purchaser's warranty period.

This warranty gives you specified legal rights. You may also have other rights which vary from state-to-state.

HOW TO OBTAIN SERVICE

For service, contact the Factory Authorized Service Agency in your area, the dealer from whom you purchased the appliance, or write us at the address shown below.

We want you to be a satisfied customer. If a problem arises that has not been resolved to your satisfaction, please let us know. Write to:

Customer Support Department
5551 McFadden Avenue
Huntington Beach, CA 92649

or phone:

(800) 735-4328

Please be sure to include the Model Number, Serial Number (located on the data sticker), and the Date of Original Purchase.

SERVICING THE COMPONENTS

OVEN COMPONENT LOCATIONS

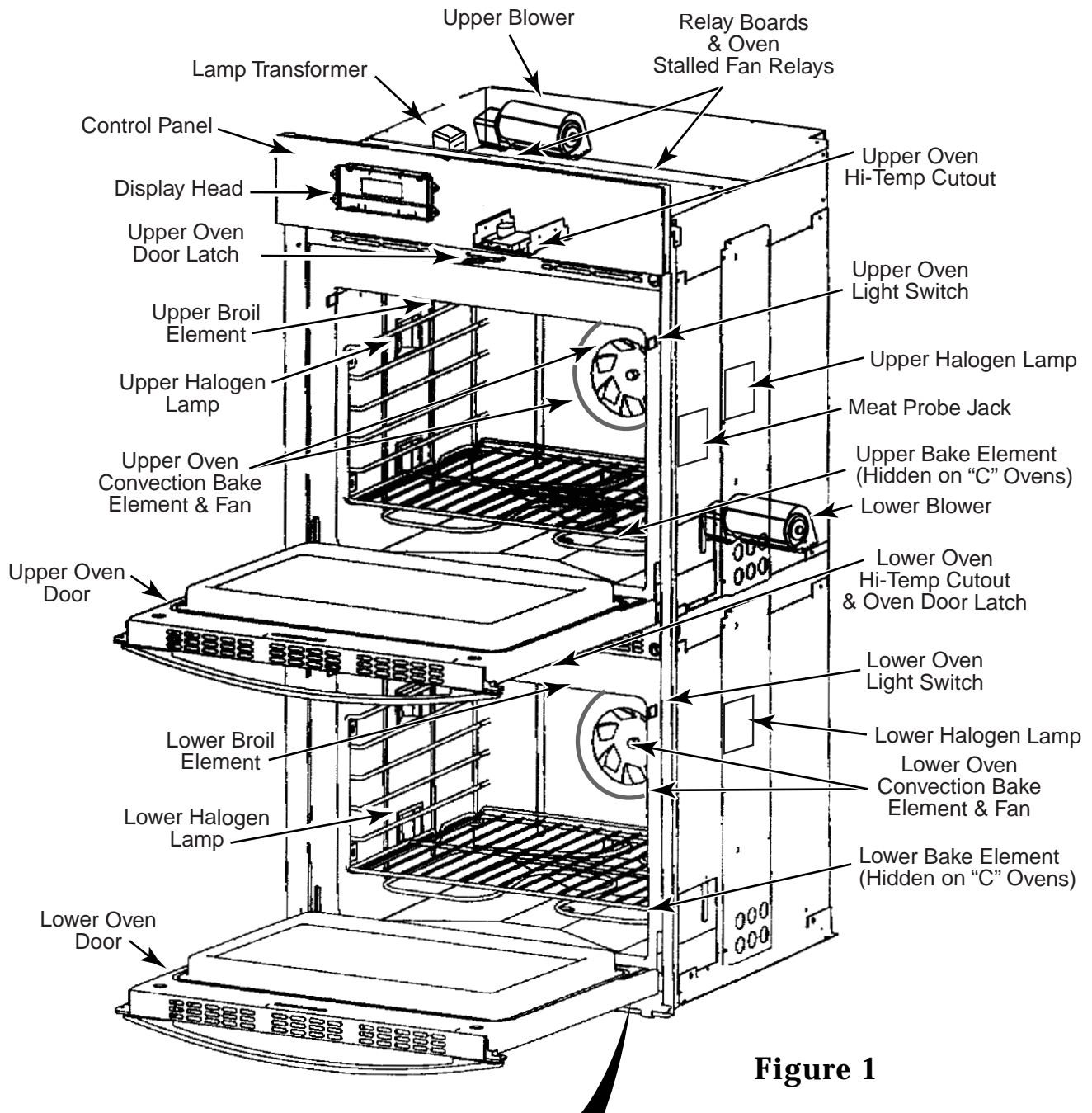

Figure 1

REMOVING THE BAKE & BROIL ELEMENTS, CATALYST, & MEAT PROBE JACK ("C" MODEL OVENS ONLY)

WARNING

Turn off the electrical power circuit to the oven at the main junction box before servicing this unit.

CAUTION

When you work on the oven, be careful when handling the sheet metal parts. There are sharp edges present and you can cut yourself if you are not careful.

1. Turn off the electrical power to the oven.
2. To make servicing easier, remove the oven door (see page 2-29).
3. Remove the racks from the oven.
4. **To remove the broil element (see Figure 3):**
 - a) Remove the screws from the broil element brackets on the rear of the oven liner, and the screws from the two top front brackets of the element. Then, remove the four screws from the shield, lower the broil element, and pull it forward.
 - b) Tie a 12" piece of string around each of the wire connectors so you can retrieve the wires if they should slide back inside the liner.
 - c) Disconnect the wires from the broil element terminals.
 - d) Connect the wires to the terminals of the new broil element, remove the string,
- and mount the element to the liner with its mounting screws. **NOTE:** Do not allow the wires to "bunch up" inside the insulation material when pushing them into the liner holes.
5. **To remove the catalyst (see Figure 4):**
 - a) Remove the screws and pull it out of the oven cutout.
 - b) Install the new catalyst.
6. **To remove the meat probe jack ("C" Model Ovens Only) (see Figure 5):**
 - a) From inside the oven, lift the cover and remove the hex nut from the meat probe jack.
 - b) From outside the oven, remove the screw from the access panel on the right side of the oven.
 - c) Disconnect the two white wires from the terminals of the meat probe jack.
7. Reassemble the oven.

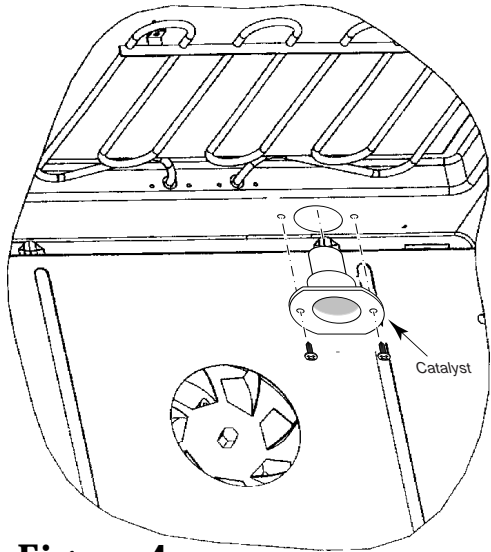
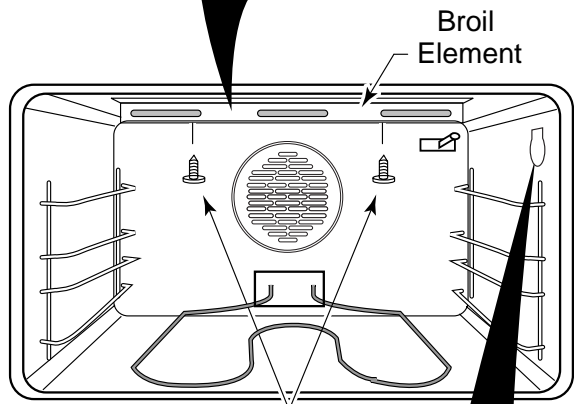
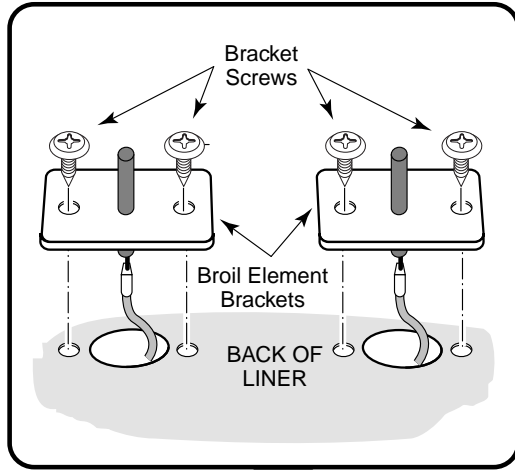

Figure 4



2 Top Front Mounting Screws

Figure 3

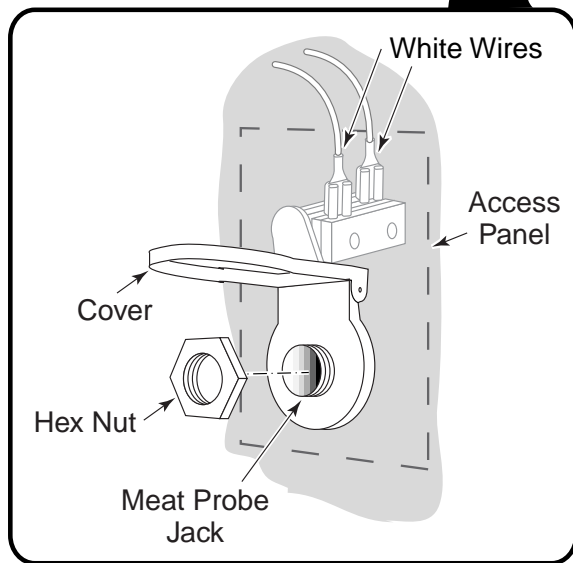

Figure 5

REMOVING THE HIDDEN BAKE ELEMENT

("C" MODEL OVENS ONLY)

WARNING

Turn off the electrical power circuit to the oven at the main junction box before servicing this unit.

CAUTION

When you work on the oven, be careful when handling the sheet metal parts. There are sharp edges present and you can cut yourself if you are not careful.

1. Turn off the electrical power to the oven.
2. Pull the oven out of its mounting location so that you can access the back.
3. Remove the screws from the rear panel and remove the panel (see Figure 6).

Refer to Figure 7 for the following steps.

4. Unwrap and remove the indicated wire tie from the support bracket.
5. Remove the three screws from the support bracket and rotate it to the right so you can access the flange at the bottom of the oven.
6. Remove the six screws from the flange.
7. Remove the two wires from the bake element.
8. Refer to Figure 8 and bend the bottom flange down as far as possible so that you can pull the bake element out from under the unit.

Refer to Figure 9 for the following steps.

9. Remove the screws from the hidden element cover and remove the cover.
10. Remove the two screws from the hidden bake element and pull the element out from the unit. NOTE: Be careful not to tear the insulation under the element.

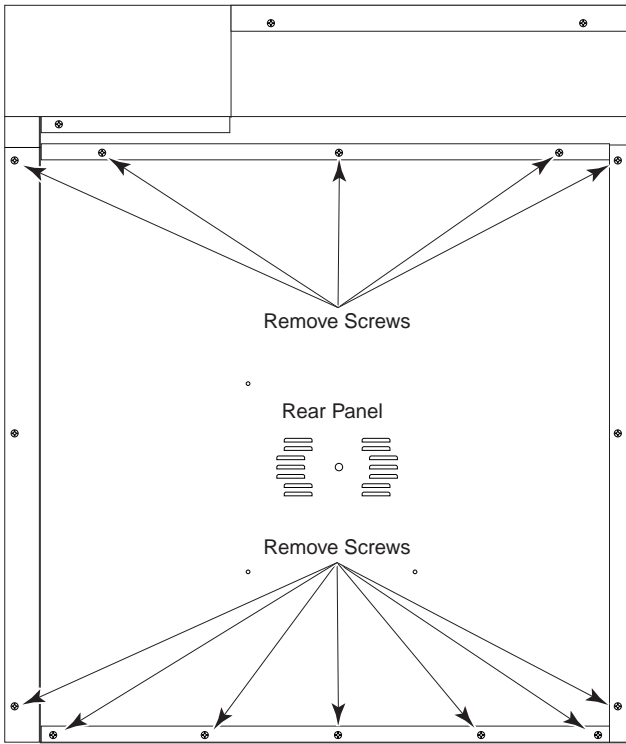

Figure 6

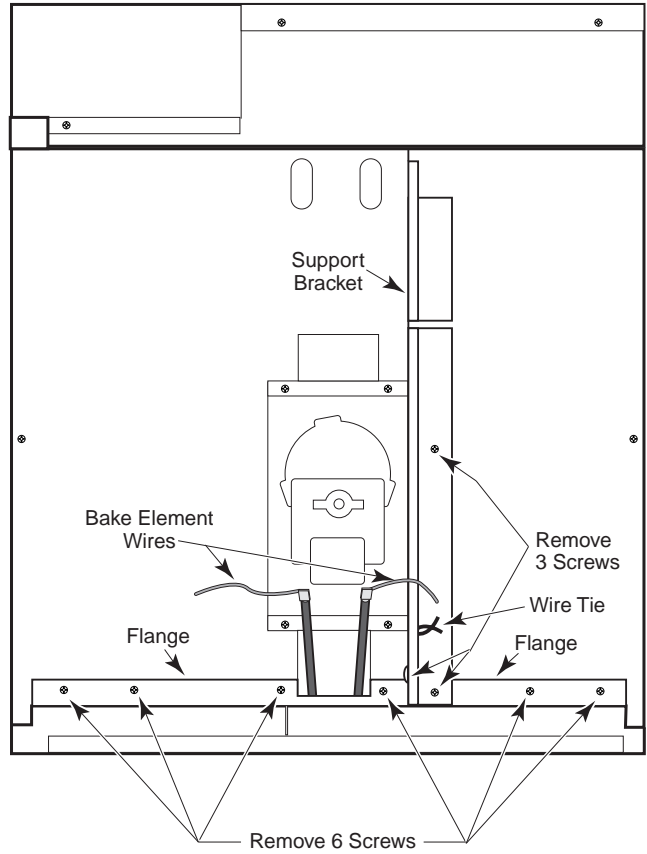

Figure 7

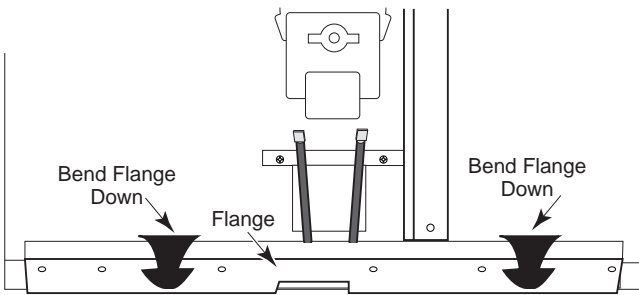

Figure 8

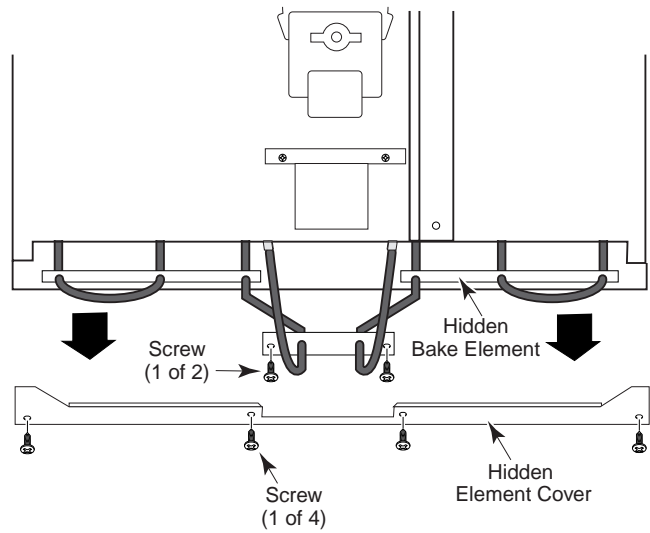

Figure 9

REMOVING THE OVEN TEMPERATURE SENSOR

⚠ WARNING

Turn off the electrical power circuit to the oven at the main junction box before servicing this unit.

⚠ CAUTION

When you work on the oven, be careful when handling the sheet metal parts. There are sharp edges present and you can cut yourself if you are not careful.

Refer to Figure 10 for the following steps.

1. Turn off the electrical power to the oven.
2. To make servicing easier, remove the oven door (see page 2-29).
3. Remove the racks from the oven.
4. Remove the screws from the bracket and pull the oven temperature sensor forward until the wire connectors are through the opening.
5. Cut the inline splices from the oven temperature sensor and main harness wires.
6. Connect the wires from the new oven temperature sensor to the main harness wires with two red inline splices. After you connect the wires, pull on them to make sure that the inline splices are secure.
7. Use a screwdriver and push the wires into the back of the oven as far as they will go, then install the oven temperature sensor in the oven liner with its two screws.
8. Reassemble the oven.

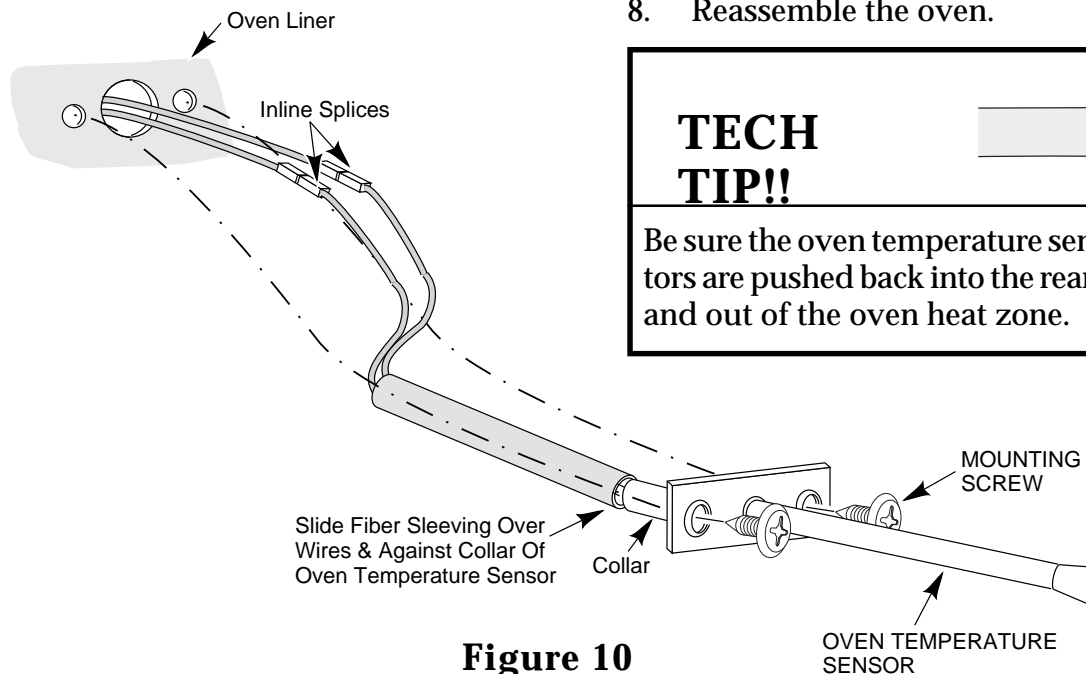
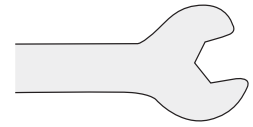

Figure 10

TECH TIP!!



Be sure the oven temperature sensor connectors are pushed back into the rear of the oven and out of the oven heat zone.

REMOVING THE CONVECTION BAKE ELEMENT

⚠ WARNING

Turn off the electrical power circuit to the oven at the main junction box before servicing this unit.

⚠ CAUTION

When you work on the oven, be careful when handling the sheet metal parts. There are sharp edges present and you can cut yourself if you are not careful.

Refer to Figure 11 for the following steps.

1. Turn off the electrical power to the oven.
2. To make servicing easier, remove the oven door (see page 2-29).
3. Remove the racks from the oven.
4. Remove the front screws from the left and right oven rack supports and remove the supports from the oven liner.
5. Remove the screws from the convection baffle and remove the baffle from the back of the oven liner.
6. Remove the screws from the convection bake element bracket and the screw from the bottom support and pull the element forward, then disconnect the wires from the terminals.
7. Install the new convection bake element and connect the wires to the terminals.
8. Reassemble the oven.

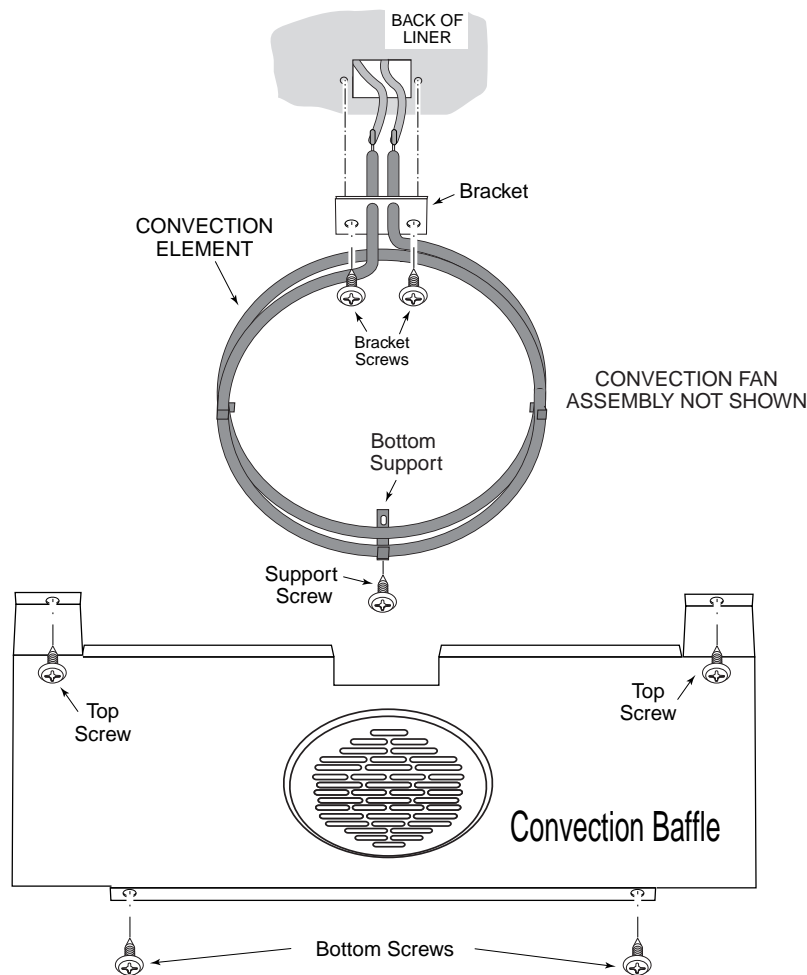

Figure 11

REMOVING A CONVECTION FAN MOTOR

WARNING

Turn off the electrical power circuit to the oven at the main junction box before servicing this unit.

CAUTION

When you work on the oven, be careful when handling the sheet metal parts. There are sharp edges present and you can cut yourself if you are not careful.

Refer to Figure 12 for the following steps.

1. Turn off the electrical power to the oven.
2. To make servicing easier, remove the oven door (see page 2-29).
3. Remove the racks from the oven.
4. Remove the front screws from the left and right oven rack supports and remove the supports from the oven liner.
5. Remove the screws from the convection baffle and remove the baffle from the back of the oven liner.
6. Remove the hex nut from the front of the convection blade. NOTE: The nut has left-rotating threads.
7. Remove the flat washer and e-ring from the convection blade and remove the blade from the motor shaft.
8. Remove the screws from the pan and remove the pan.
9. Remove the motor screws from the bracket and remove the motor from the bracket.
10. Disconnect the two wires from the fan motor terminals.
11. Connect the brown wire (#45) to the right terminal of the new convection fan motor, and the white wire (#44) to the left terminal, then install the motor assembly.
12. Reassemble the oven.

TECH TIP!!

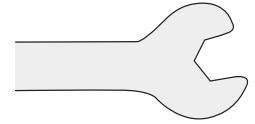

The convection blade hex nut has left-rotating threads.

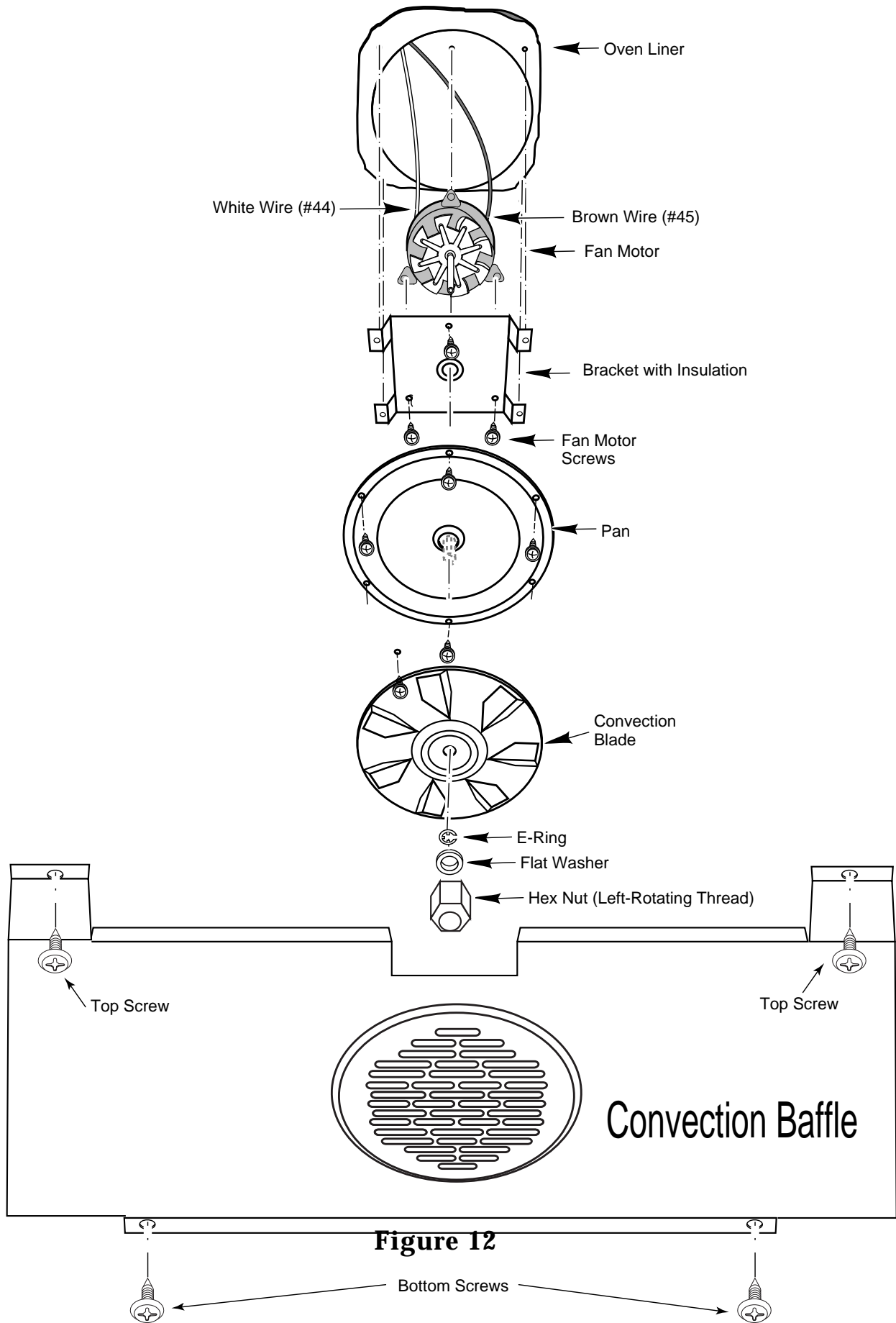

Figure 12

REMOVING A HALOGEN LAMP HOLDER

WARNING

Turn off the electrical power circuit to the oven at the main junction box before servicing this unit.

CAUTION

When you work on the oven, be careful when handling the sheet metal parts. There are sharp edges present and you can cut yourself if you are not careful.

Refer to Figure 13 for the following steps.

1. Turn off the electrical power to the oven.
2. Remove the oven racks.
3. Remove the oven rack support for the halogen lamp holder you are removing.

CAUTION: Make sure that the halogen bulb is cool before you remove it in the next step.

4. Pull the lamp cover out of the halogen lamp holder and remove the bulb.

5. Pry the lamp holder out of the oven liner and cut the wires approximately 2" from the lamp holder body. **CAUTION: Be careful not to chip or scratch the oven liner when you pry the lamp holder out of the cutout.**
6. Cut the plug off the new lamp holder.
7. Connect the cut wires to the new lamp holder with two red inline splices. After you connect the wires, pull on them to make sure that the inline splices are secure.
8. Gently pull the lamp holder wires up into the plenum area until you can see the red wire splices in the plenum area.
9. Reassemble the oven.

TECH TIP!!

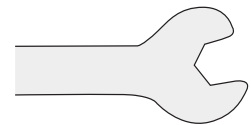

Make sure that the two red inline splices are in the top plenum area and not in the oven heat zone.

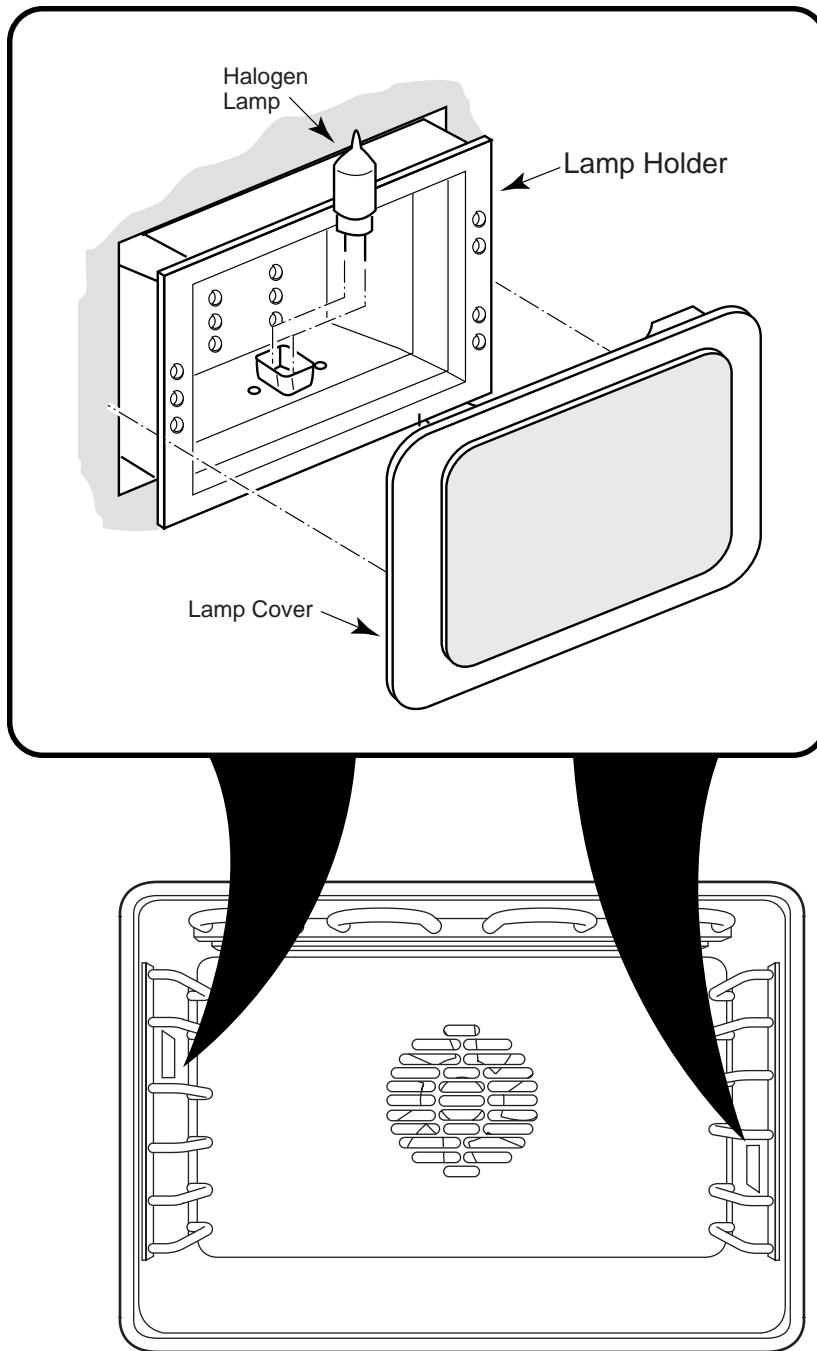

Figure 13

REMOVING THE CONTROL PANEL ("C" MODEL OVENS ONLY)

⚠ WARNING

Turn off the electrical power circuit to the oven at the main junction box before servicing this unit.

⚠ CAUTION

When you work on the oven, be careful when handling the sheet metal parts. There are sharp edges present and you can cut yourself if you are not careful.

1. Turn off the electrical power to the oven.
2. Pull the oven out of its mounting location just far enough to access the front and rear plenum covers.
3. Remove the plenum front and rear covers (see Figure 14).

Refer to Figure 15 on the next page for the following steps:

4. Open the upper oven door.
5. Remove the bottom screw from the control panel.
6. Remove the mounting screw from the detent pin clip and unhook the clip from the detent pin (see inset 1).
7. Turn the latch 90° so that the sides align with the cutout in the latch catch (see inset 2).
8. Rotate the bottom of the control panel assembly out and unhook the detent pins from the pivot bracket slots (see inset 1).
9. Unplug the orange and yellow 9-wire connectors from the relay board at P10 and P11.
10. Unplug connectors P2 and P6 from the display head.

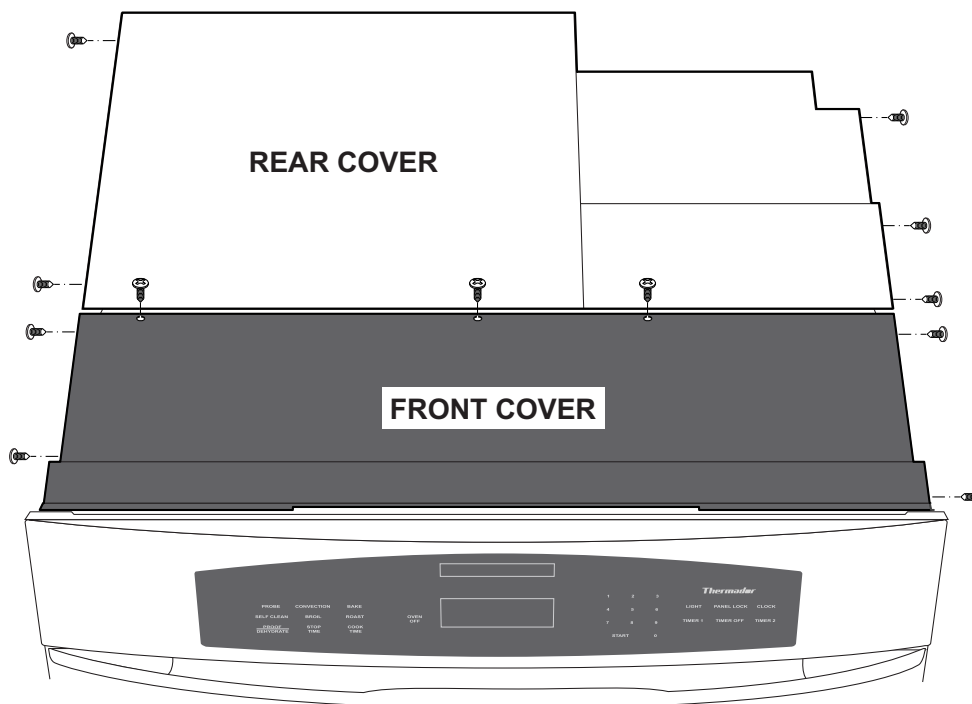

Figure 14

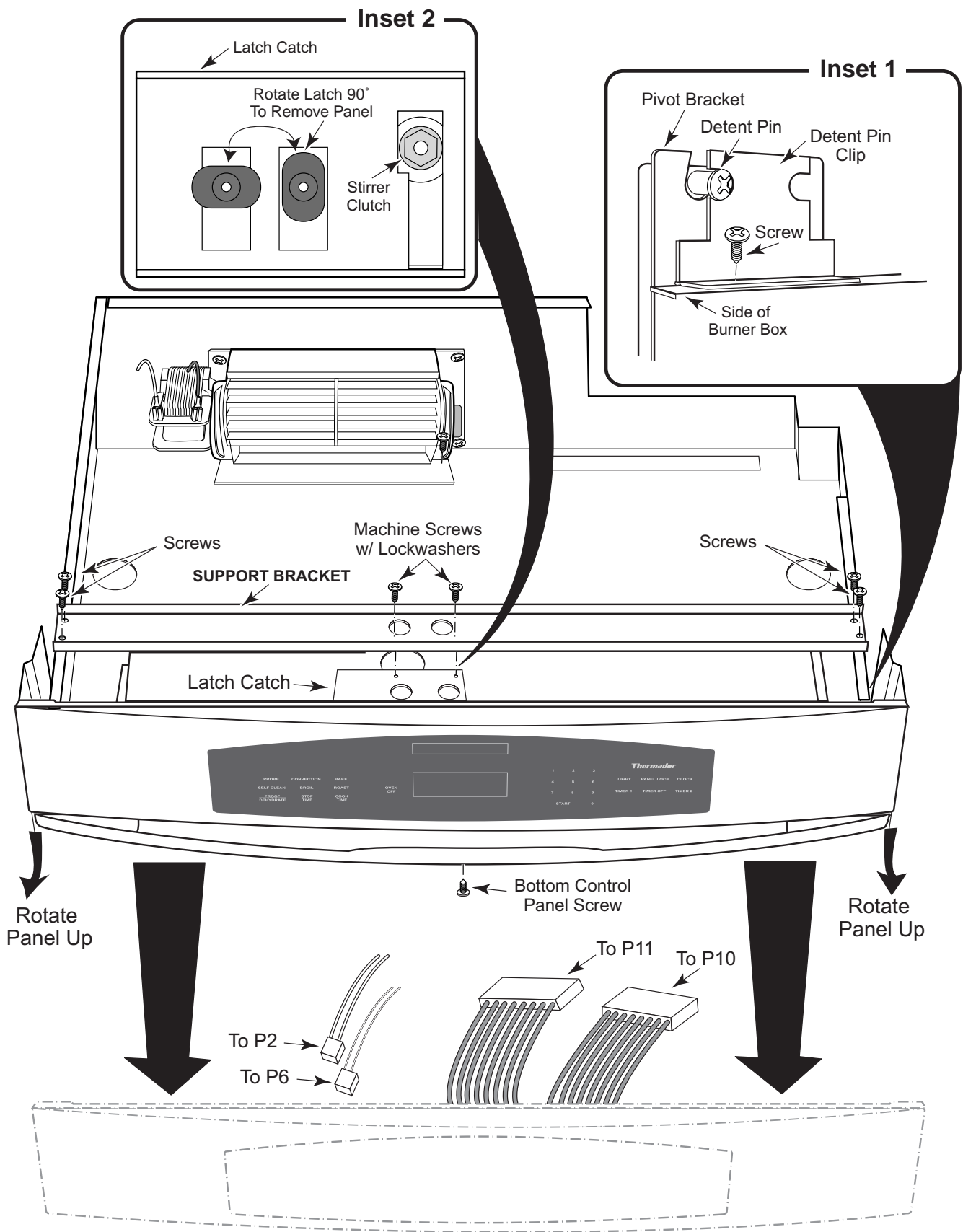

Figure 15

REMOVING THE GLASS & DISPLAY HEAD

("C" MODEL OVENS ONLY)

WARNING

Turn off the electrical power circuit to the oven at the main junction box before servicing this unit.

CAUTION

When you work on the oven, be careful when handling the sheet metal parts. There are sharp edges present and you can cut yourself if you are not careful.

1. Turn off the electrical power to the oven.
2. Remove the control panel from the oven (see pages 2-12 & 2-13) and position it face down on a padded surface to protect the finish.
3. Disconnect the nine (9) cables from the left and right touch control board connectors (see Figure 16A).
4. Remove the four control panel plate screws (two on each end) and lift it and the wiring off the control panel (see Figure 16A).
5. **To remove the glass and two touch control boards**, lift the glass off the control panel (see Figure 16B). NOTE: The touch control boards are part of the glass and must be replaced with the glass.
6. **To remove the display head**, remove the four screws holding it to the control panel plate (see Figure 16C).
7. Reassemble the oven.

REASSEMBLY NOTE: When you reinstall the control panel plate over the glass, make sure that the top of the display bracket is hooked over the top edge of the glass to align it properly when the four screws are installed (see Figure 16D). Keep the top edge of the glass against the bracket

Front Panel (Rear View)

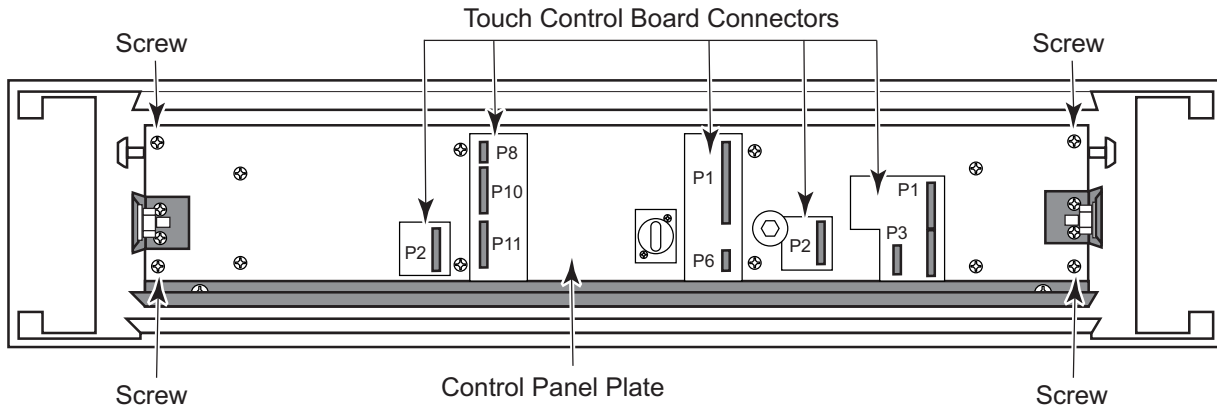

Figure 16A

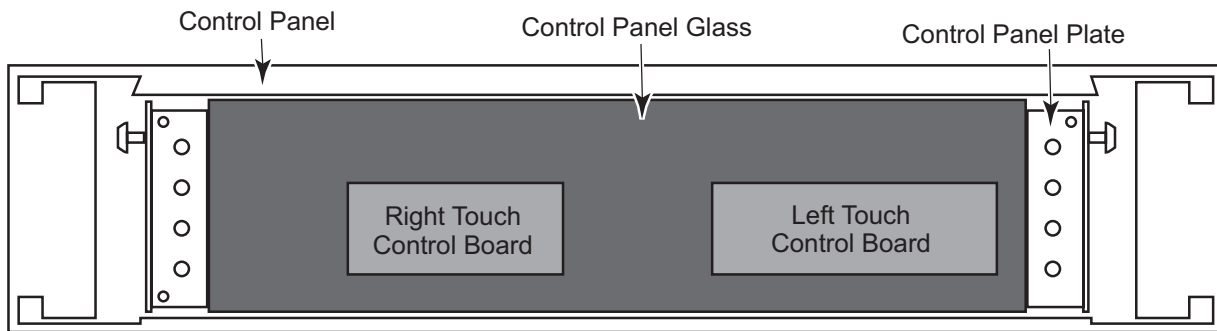

Figure 16B

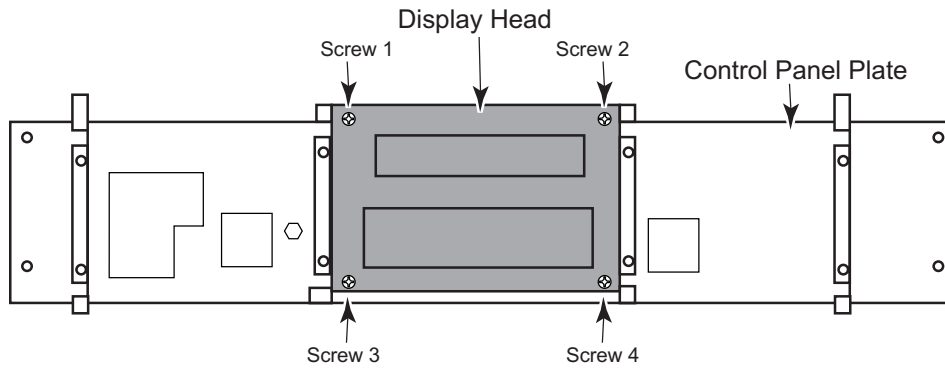

Figure 16C

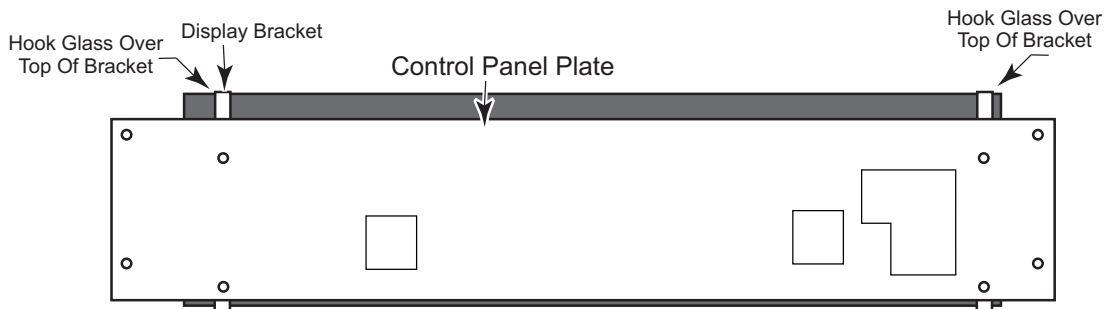

Figure 16D

REMOVING THE OVEN LIGHT SWITCH, THE OVEN DOOR LATCH ASSEMBLY and THE HI-TEMP CUTOUT

⚠ WARNING

Turn off the electrical power circuit to the oven at the main junction box before servicing this unit.

⚠ CAUTION

When you work on the oven, be careful when handling the sheet metal parts. There are sharp edges present and you can cut yourself if you are not careful.

Refer to Figure 19 on the next page for the following steps.

1. Turn off the electrical power to the oven.
2. Open the oven door for the component you wish to remove.
3. **To remove the upper air vent grille**, remove the four bottom screws and the two front oven door latch screws.
4. **To remove the lower air vent grille**, remove the two front oven door latch screws, (see Figure 18), then pull the posts on the ends of the air vent grille out of the catches in the chassis.
5. **To remove the oven light switch**, disconnect the wires from the terminals, press in on the locking arms, and push the switch out of the vent (see inset 1).
6. **To remove the oven door latch assembly (see inset 2):**
 - a) Use a 1/4" ratchet and a 1/4" thin-wall socket and remove the two front hex-head screws from the latch bracket.
 - b) Pull the latch assembly to the right so that the flange on the left side clears the bracket, and then pull it forward as far as the wires will allow.
 - c) Remove the wires from the switch connectors and the motor wires from the main harness.
 - d) **To replace a door lock or door unlock switch on the latch assembly**, remove the two screws from the switch body, and remove the switch.
7. **To remove the hi-temp cutout (see inset 3):**
 - a) Remove the two 1/4" hex-head screws from the bracket.
 - b) Remove the hi-temp cutout and disconnect the wires.
8. Install the replacement component.
9. Reassemble the oven.

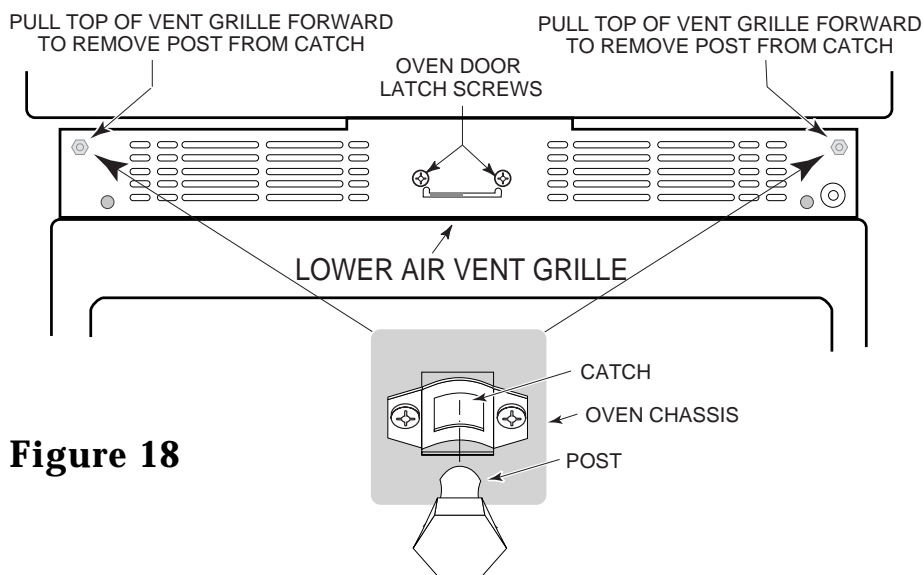
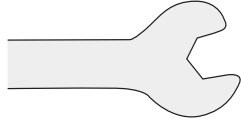

Figure 18

TECH TIP!!



You will need the following tools to remove the components:

- 1/4" ratchet
- 1/4" thin-wall socket
- #2 Phillips Offset Screwdriver

Inset 1

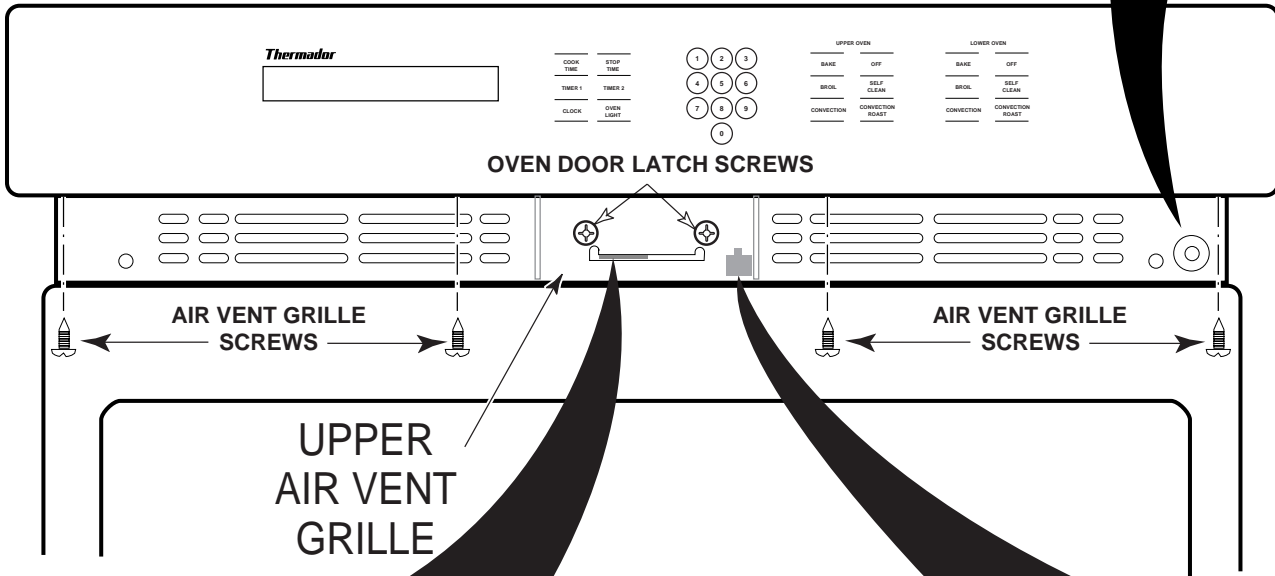
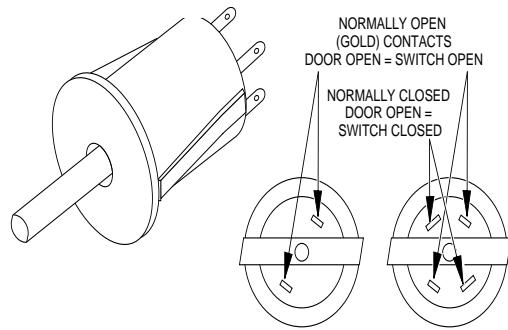

Inset 2

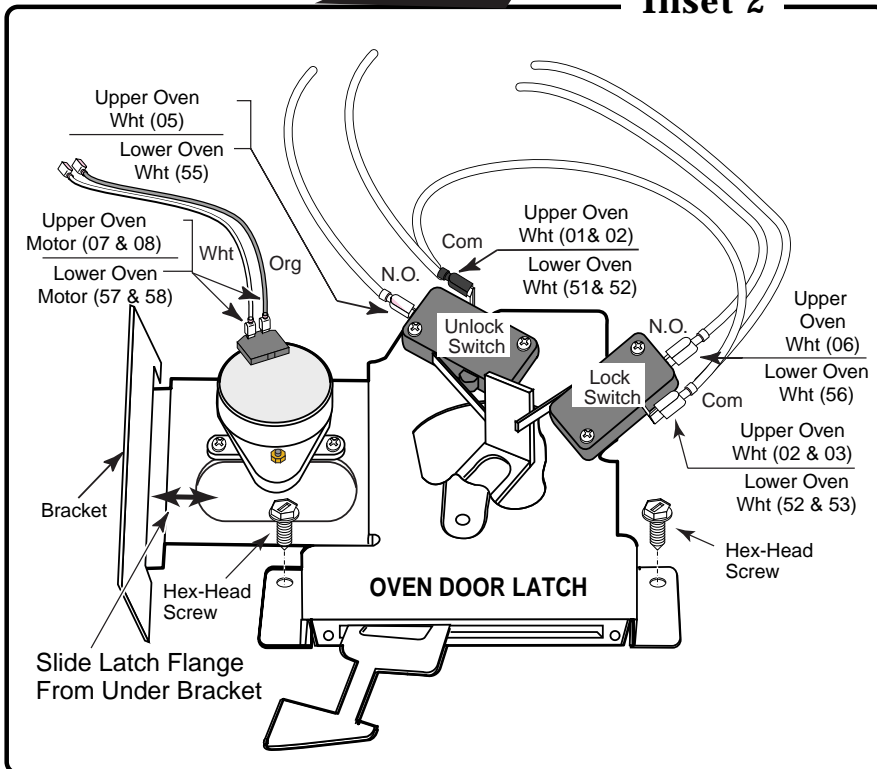

Inset 3

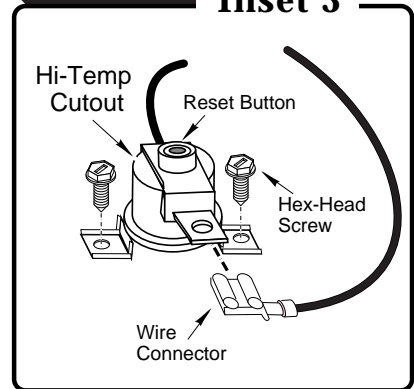

Figure 19

REMOVING THE BLOWER, DOUBLE LINE BREAK RELAY, LAMP TRANSFORMER and RELAY BOARD

WARNING

Turn off the electrical power circuit to the oven at the main junction box before servicing this unit.

CAUTION

When you work on the oven, be careful when handling the sheet metal parts. There are sharp edges present and you can cut yourself if you are not careful.

Refer to Figure 20 for the following steps.

1. Turn off the electrical power to the oven.
2. To make servicing easier, remove the oven door (see page 2-29).
3. Remove the oven from the wall.
4. **To remove the blower (see Figure 16):**
 - a) Remove the screws from the front and rear plenum covers and remove the covers (see page 2-12 for the procedure).
 - b) Remove the screws from the blower motor bracket on the back of the plenum and turn the assembly around so that the back faces you.
 - c) Remove the screws that mount the motor to the bracket.
 - d) Disconnect the wires from the motor terminals.
 - e) Install the new blower in the mounting bracket and mount the assembly to the plenum.
5. **To remove the oven stalled fan relay (see the inset):**
 - a) Remove the screws and disconnect the wires from the terminals.
 - b) Install the new oven stalled fan relay with the terminals positioned as shown and reconnect the wiring.
6. **To remove the lamp transformer (see the inset):**
 - a) Remove the screws and ground lug.
 - b) Disconnect the wires from the terminals.
 - c) Install the new lamp transformer and reconnect the wiring.
7. **To remove the relay board (see the inset):**
 - a) Remove the screws from the support bracket and remove the bracket.
 - b) Disconnect the wires from the relay board terminals.
 - c) Remove the screws from the board and remove it from the plenum.
 - d) Install the new relay board and reconnect the wiring.
8. Reassemble the oven.

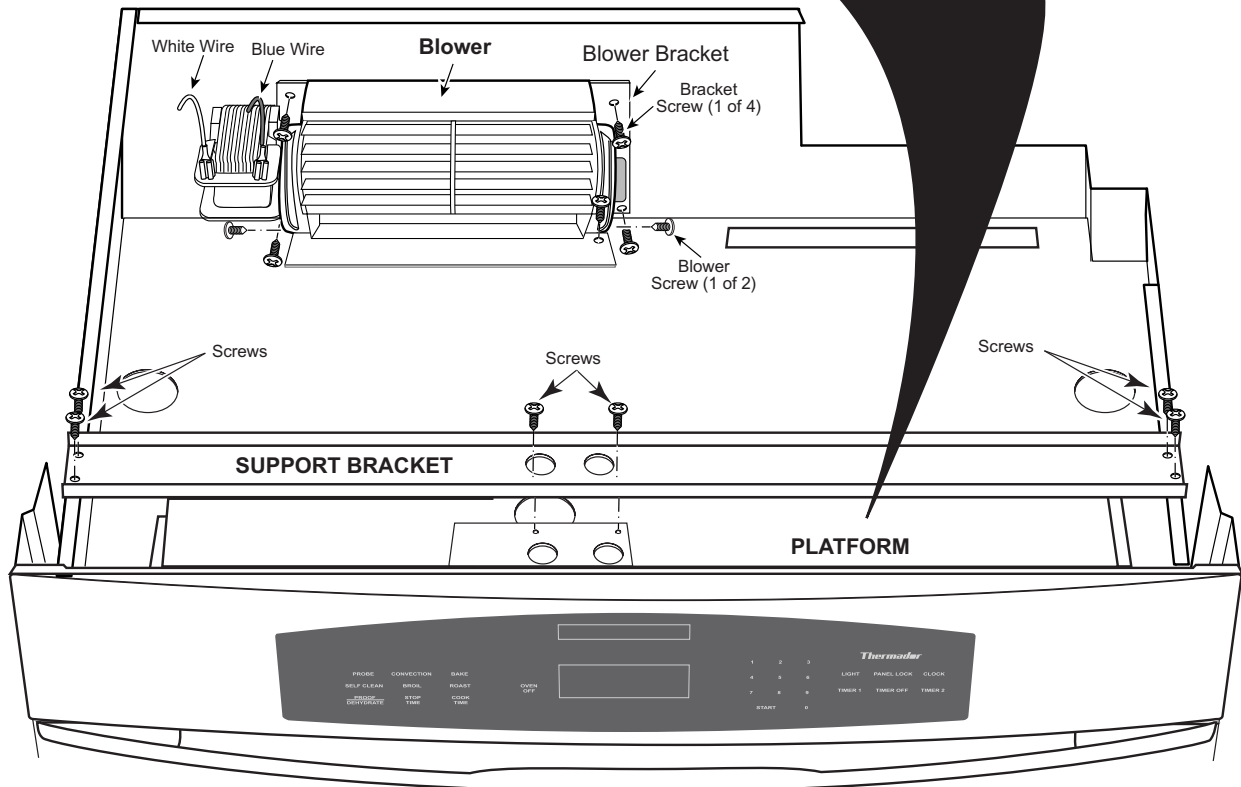
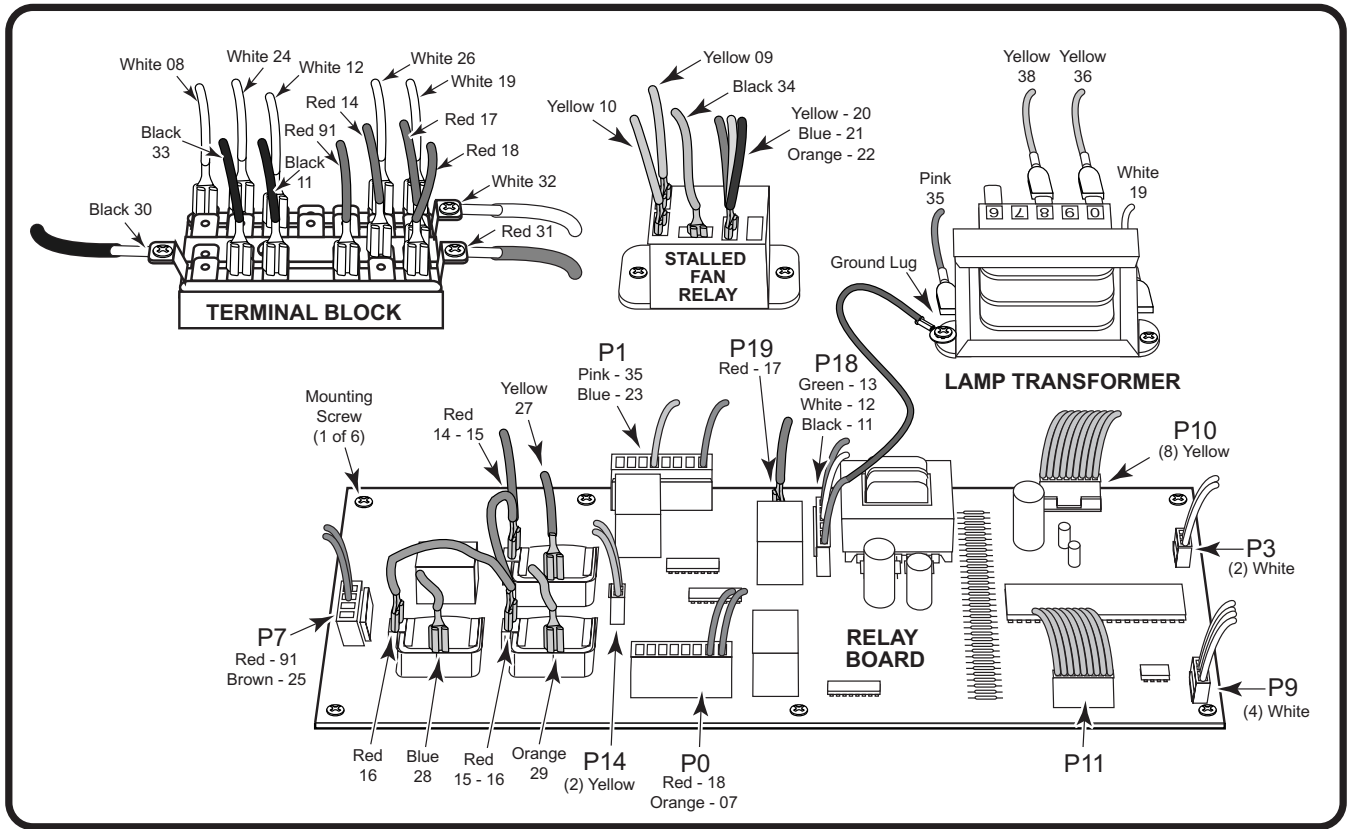

Figure 20

REMOVING THE AIR SWITCHES

⚠ WARNING

Turn off the electrical power circuit to the oven at the main junction box before servicing this unit.

⚠ CAUTION

When you work on the oven, be careful when handling the sheet metal parts. There are sharp edges present and you can cut yourself if you are not careful.

NOTE: The air flow to the air switch in the lower oven base compartment of all 27" S-Series ovens has been improved with the addition of an air diverter (#16-10-101). This improvement has been made to all 27" and 30" ovens built in 1998. The new air diverter is located on the right side of the lower oven base compartment (see Figure 24 below). If you encounter a 27" oven that was built in 1997 with no oven heat, due to the air switch not closing, order and install the new diverter. You will not see any error code messages in control display window if these problems occur.

Refer to Figure 25 on the next page for the following steps.

1. Turn off the electrical power to the oven.

2. Open the lower oven door. The bottom trim mounting screws (see inset 1) are visible at each side of the oven door, below the left and right hinges.
3. Remove the two screws from the bottom trim, pull it forward, and remove it.
4. Remove the two front switches from the air switch bracket and flange, and pull the air switch bracket assembly forward so you can access the switches (see inset 2).
5. To remove an air switch from the bracket, remove the two screws from the switch body, and disconnect the wires from the terminals (see inset 3).
6. Install the new air switch in the mounting bracket.
7. If you intend to install the air switch diverter, do so at this time. Make sure that the spacing between the air switch paddle and the end of the diverter is as shown below.
8. Reassemble the oven.

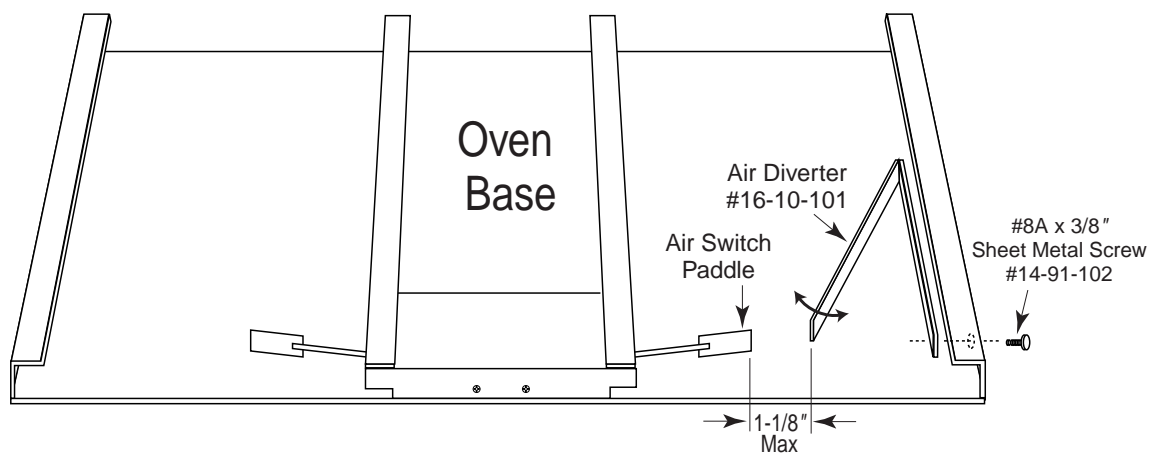

Figure 24

NOTE: After mounting the air diverter, bend the arm, as necessary, so that the space between the air switch paddle and the end of the arm is as shown.

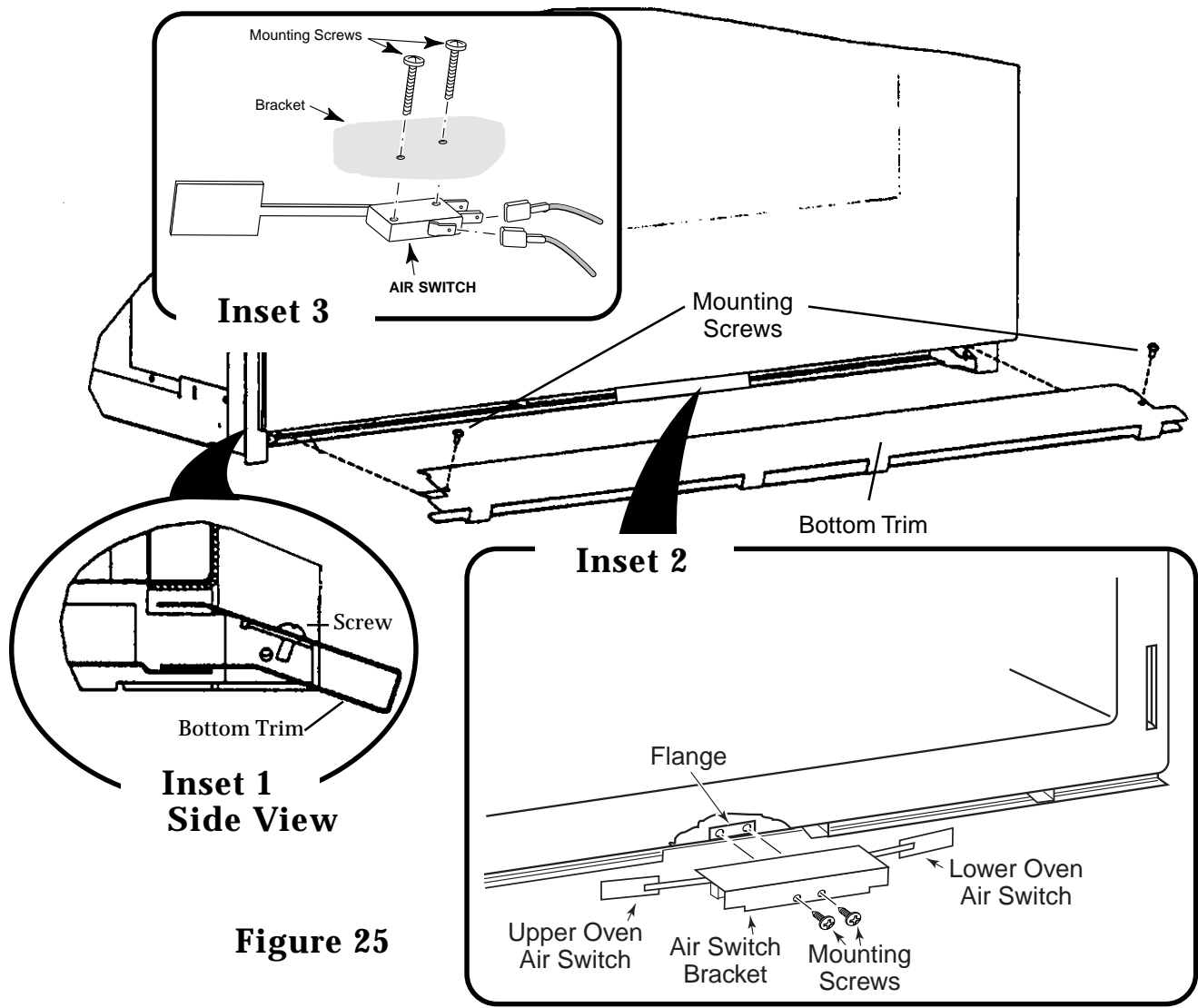

Figure 25

REMOVING A BLOWER

WARNING

Turn off the electrical power circuit to the oven at the main junction box before servicing this unit.

CAUTION

When you work on the oven, be careful when handling the sheet metal parts. There are sharp edges present and you can cut yourself if you are not careful.

1. Turn off the electrical power to the oven.
2. To make servicing easier, remove the oven door (see page 2-29).
3. **To remove the upper blower (see Figure 26):**
 - a) Remove the oven from the wall.
 - b) Remove the screws from the front and rear plenum covers and remove the covers (see page 2-12 for the procedure).
 - c) Remove the three screws from the blower motor bracket on the back of the plenum and turn the assembly around so that the back faces you.
 - d) Remove the three screws that mount the motor to the bracket.
 - e) Disconnect the four wires from the motor terminals.
 - f) Install the new blower in the mounting bracket and mount the assembly to the plenum.
4. **To remove the lower blower (see Figure 27):**
 - a) Remove the oven from the wall.
 - b) Remove the rear panel from the oven.
 - c) Remove the four bracket screws (1,2,6, & 7) from the back of the oven.
 - d) Remove the three blower screws (3, 4, & 5) from the bracket and remove the motor.
 - e) Loosen the wire ties and remove the two motor wires from the rest of the wire harness.
 - f) Install the new blower in the mounting bracket, mount the assembly to the back of the oven, and connect the wires.
 - g) Install the motor wires in the wire harness ties with the rest of the wires and dress them neatly.
5. Reassemble the oven.

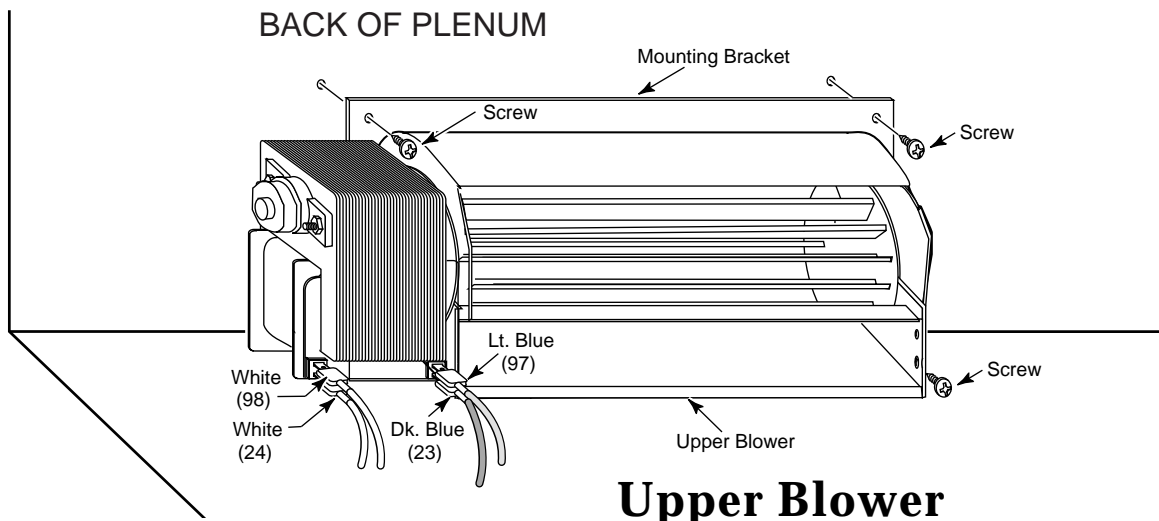

Upper Blower
Figure 26

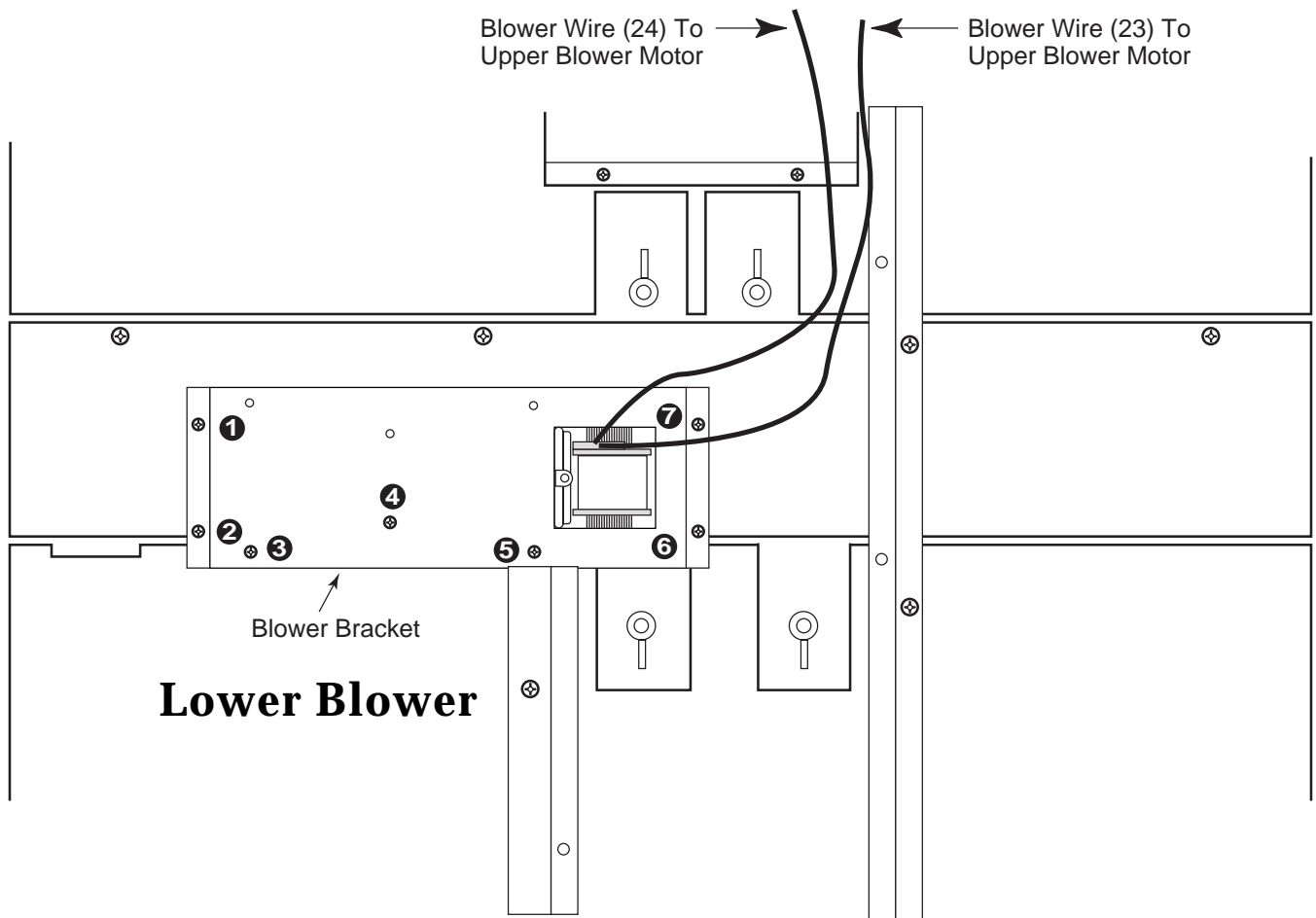

Figure 27

Removing the Lamp Transformer & the Upper or Lower Oven Double Line Break Relay

⚠ WARNING

Turn off the electrical power circuit to the oven at the main junction box before servicing this unit.

⚠ CAUTION

When you work on the oven, be careful when handling the sheet metal parts. There are sharp edges present and you can cut yourself if you are not careful.

1. Turn off the electrical power to the oven.
2. Open the upper oven door.
3. Remove the control panel and display head (see pages 2-16 and 2-17 for the procedure).
4. Remove the front subpanel (see page 2-22).
5. **To remove the lamp transformer (see Figure 28):**
 - a) Remove the screws and disconnect the wires from the terminals.
 - b) Install the new lamp transformer and reconnect the wiring.

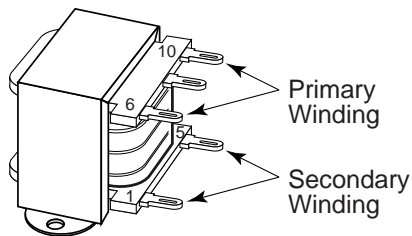

Figure 28

6. **To remove an oven stalled fan relay (see Figure 29):**
 - a) Remove the screws and disconnect the wires from the relay terminals.
 - b) Install the new oven stalled fan relay with the terminals positioned as shown and reconnect the wiring.

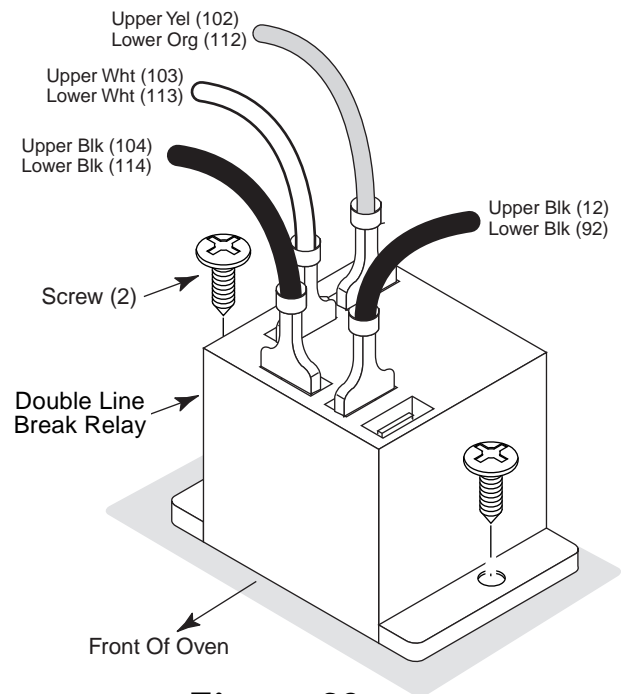

Figure 29

7. Reassemble the oven.

REMOVING AN OVEN DOOR

Refer to Figure 30 for the following steps.

1. Open the door to its fully open position.
2. Raise the hinge latch over the hook on each of the hinges.

3. **To remove the door:**

- a) Grasp the door by the sides toward the back and raise the front of the door several inches (there will be some resistance in the spring mechanism because the hinge is locked).
- b) When the door is high enough, lift it until the hinges clear the indents, and pull it out of the slots in the front frame.

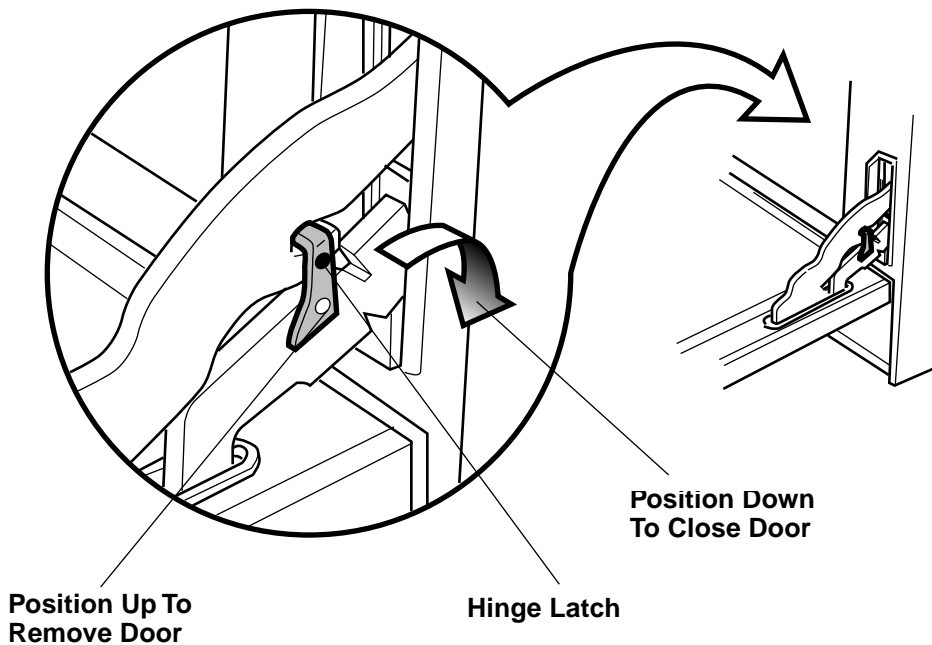

Figure 30

REMOVING THE OVEN DOOR GASKET

⚠ CAUTION

When you work on the oven, be careful when handling the sheet metal parts. There are sharp edges present and you can cut yourself if you are not careful.

CAUTION: Before you replace the fiberglass gasket on the oven door, make sure that the oven control is turned OFF, and that the oven is cool.

Refer to Figure 31 for the following steps.

1. Open the oven door to its fully open position.
2. Pull the ends of the old gasket out of the holes in the door (see inset 1 on the illustration).
3. Working from one end of the gasket to the other, carefully pull the clips that are attached to the gasket out of the holes in the oven door (see inset 2 on the illustration).
4. Position the new fiberglass gasket around the oven door so that the clips are near the holes.
5. Working from one end of the gasket to the other, insert the gasket clips into the holes in the oven door. NOTE: Once inserted, gently pull on the clip to make sure that it is locked into place.
6. Using the eraser end of a pencil, push the ends of the gasket fully into the holes in the oven door.
7. Check the entire gasket to make sure that all of the clips are properly inserted, and that it is flush and even with the surface of the door.
8. Close the oven door and check to make sure that the gasket fits firmly and evenly with the front of the oven.

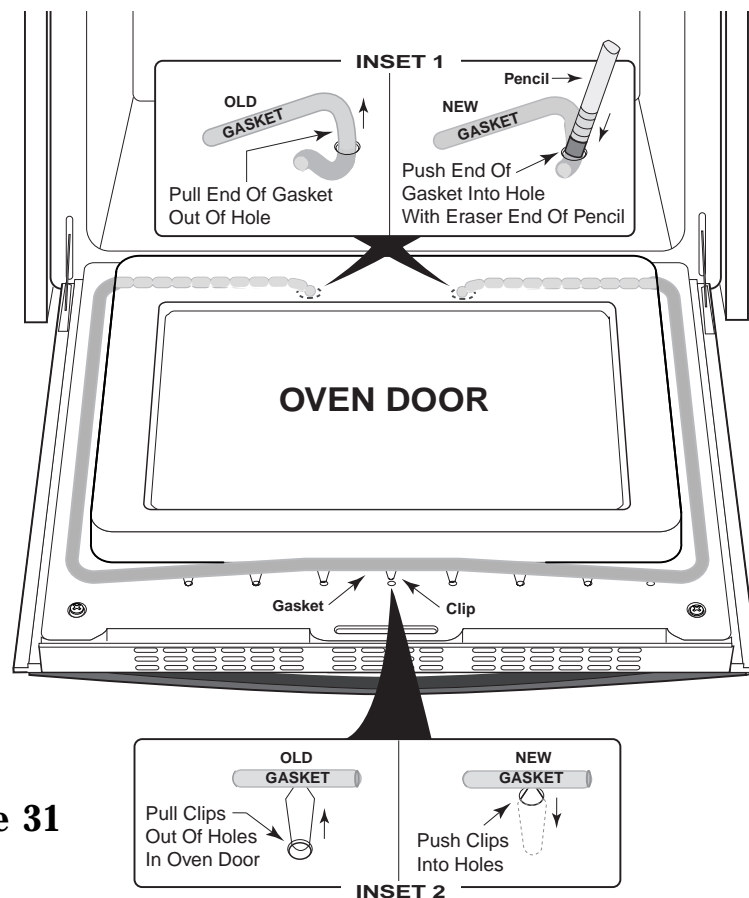

Figure 31

REMOVING THE OVEN DOOR COMPONENTS ("C" MODEL OVENS)

⚠ CAUTION

When you work on the oven, be careful when handling the sheet metal parts. There are sharp edges present and you can cut yourself if you are not careful.

1. To remove any of the oven door components, remove the oven door from the oven (see page 2-29).
2. Refer to Figure 33 as you remove the door components. The illustration shows the order of removal.

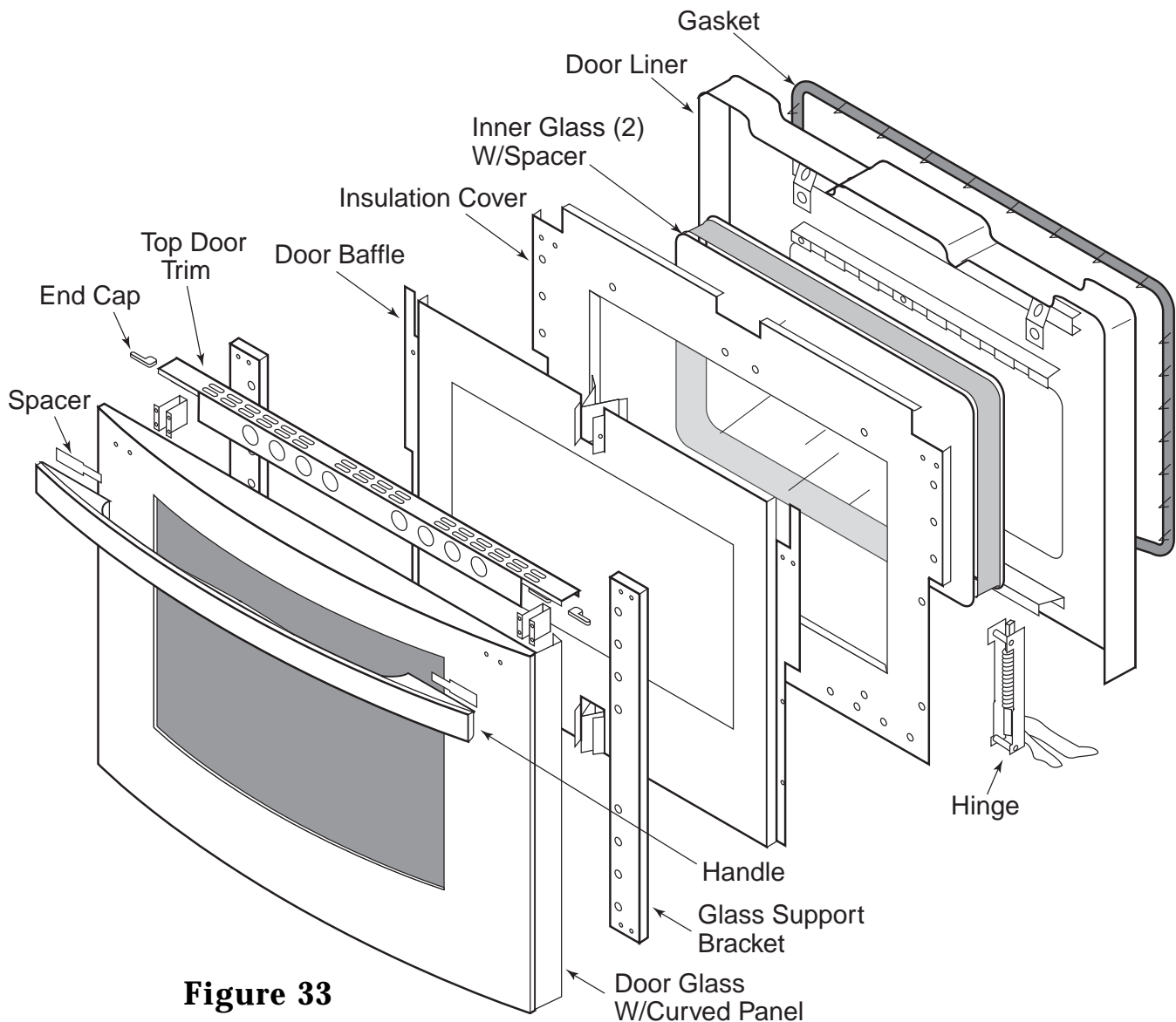

Figure 33

REMOVING THE “C” OVEN MODULE

(27") Convection Kit—#35-00-686

(30") Convection Kit—#35-00-687

⚠ WARNING

Turn off the electrical power circuit to the oven at the main junction box before servicing this unit.

⚠ CAUTION

When you work on the oven, be careful when handling the sheet metal parts. There are sharp edges present and you can cut yourself if you are not careful.

1. Turn off the electrical power to the oven.
2. To make servicing easier, remove the oven door (see page 2-29).
3. Remove the oven from the wall.
4. Remove the components from the oven, shown in Figure 35. Refer to the sections in this manual for the procedures on removing the components.
5. With all of the oven components removed, remove the six screws (three on each side) from the front sides of the oven can.
6. Pull the oven can forward and remove it.

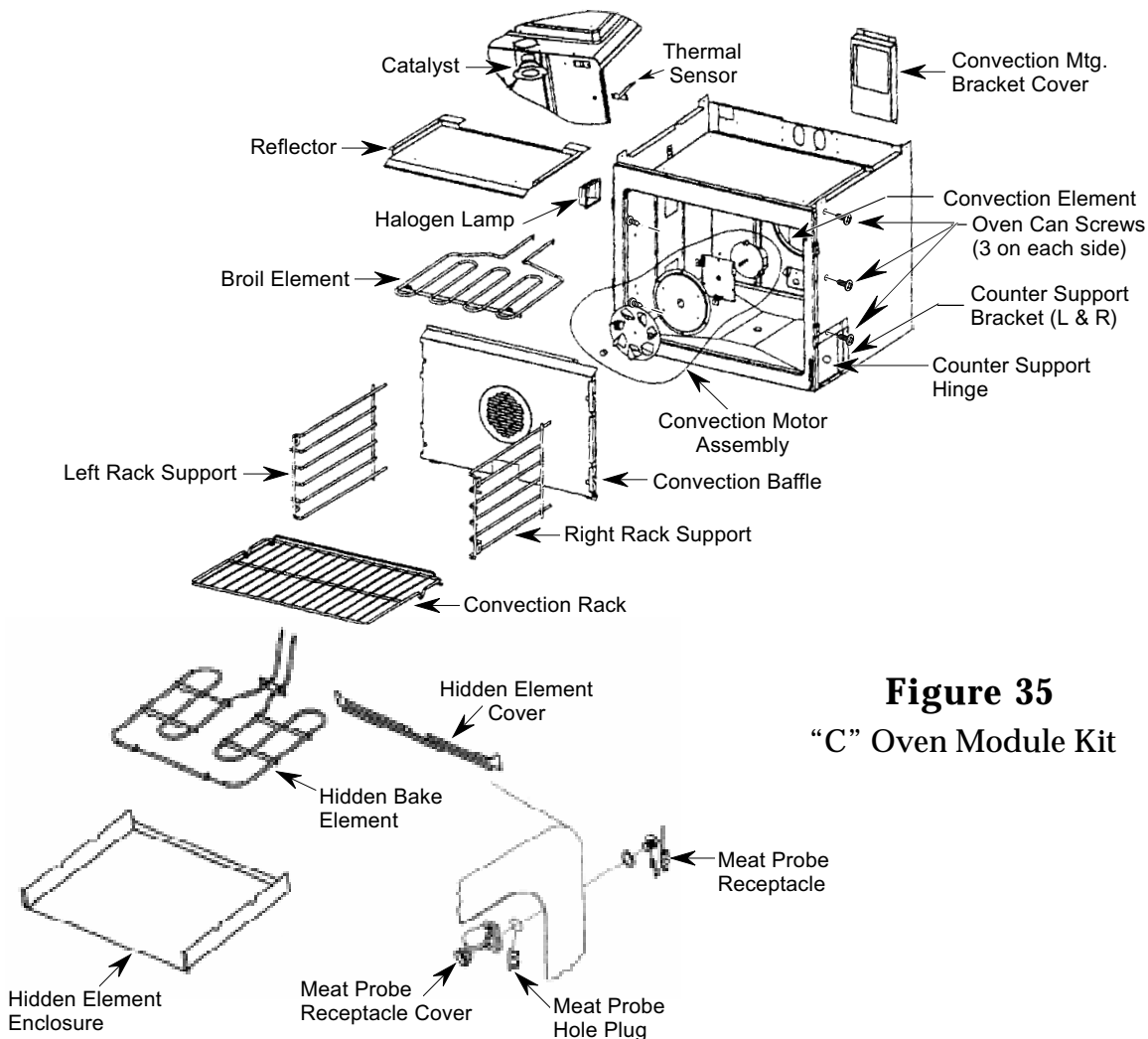

Figure 35
“C” Oven Module Kit

TROUBLESHOOTING

TESTING THE COMPONENTS

⚠ WARNING

TO AVOID ELECTRICAL SHOCK

- DISCONNECT THE POWER TO THE APPLIANCE BEFORE SERVICING.
- FOR THOSE CHECKS REQUIRING THE USE OF ELECTRICAL POWER, EXERCISE EXTREME CARE.
- DO NOT PERFORM HIGH-VOLTAGE TESTS.

THE BLOWER MOTOR

Refer to page 2-26 to access the blower motor.

1. With no power applied, disconnect the motor wire connectors from their terminals.
2. Set the ohmmeter to the R x 1 scale.
3. Touch the ohmmeter leads to the motor terminals. The meter should indicate 13 Ω .
4. If the reading is not correct, remove and replace the blower motor.

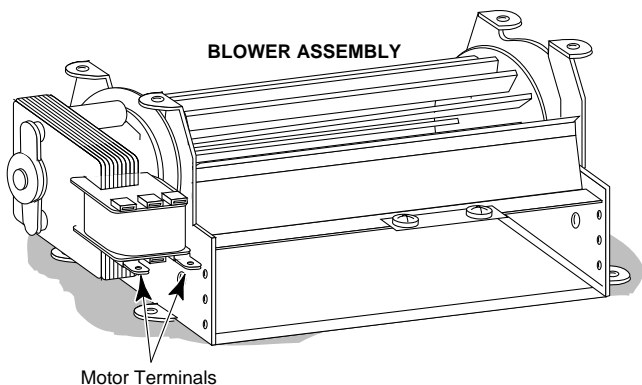

THE AIR SWITCH

Refer to page 2-24 to access the air switch.

1. With no power applied, remove the wire connectors from the terminals.
2. Set the ohmmeter to the R x 1 scale.
3. Connect one of the ohmmeter leads to the common (C) terminal of the switch (the terminal callouts are stamped on the switch).
4. Touch the free ohmmeter lead to the N.O. (normally-open) switch terminal. The meter should show no continuity with the switch in its normal position, and continuity when it is activated.
5. If the readings are not correct, remove and replace the switch.

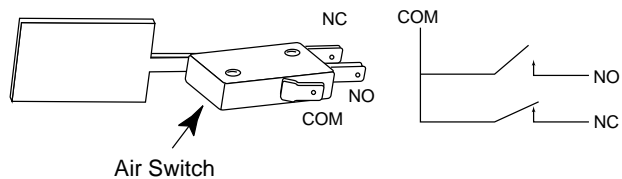

THE CONVECTION FAN MOTOR

Refer to page 2-8 to access the convection fan motor.

1. With no power applied, disconnect the motor wire connectors from their terminals.
2. Set the ohmmeter to the R x 1 scale.
3. Touch the ohmmeter leads to the motor terminals. The meter should indicate 12 Ω .
4. If the reading is not correct, remove and replace the convection fan motor.

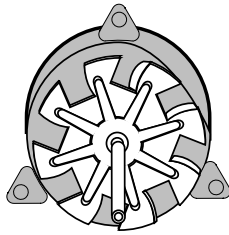

Convection Fan Motor

THE LAMP TRANSFORMER

Refer to pages 2-20 & 2-28 to access the lamp transformer.

1. With no power applied, remove the wires from the terminals of the lamp transformer.
2. Set the ohmmeter to the R x 1 scale.
3. Touch the ohmmeter leads to the primary terminals. The meter should indicate 9 Ω .
4. Touch the ohmmeter leads to the secondary terminals. The meter should indicate 2 Ω .
5. If the readings are not correct, remove and replace the lamp transformer.

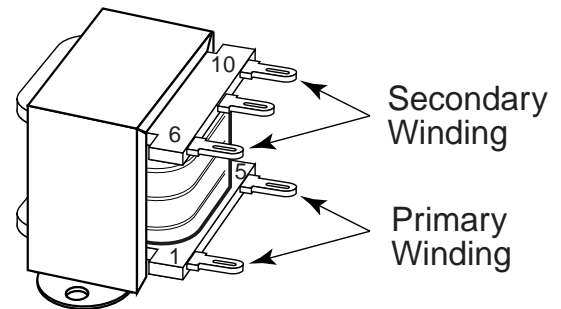

THE OVEN DOOR LATCH ASSEMBLY

The oven door latch locks the oven door during the *CLEAN* cycle (see the illustration at the bottom of the next column for the various latch positions). Refer to page 2-18 to access the oven door latch assembly.

To test one of the latch switches:

1. With no power applied, remove the wire connectors from the switch terminals.
2. Set the ohmmeter to the R x 1 scale.
3. Connect one of the ohmmeter leads to the common (C) terminal of the switch.
4. Touch the other ohmmeter lead to the N.O. (normally-open) switch terminal. The meter should indicate no continuity with the switch in its normal position, and continuity when it is activated.
5. If the reading is not correct, remove and replace

the switch.

To test the door latch motor windings:

1. With no power applied, disconnect the motor wires from the terminal block and main harness connector.
2. Set the ohmmeter to the R x 100 scale.
3. Touch the ohmmeter leads to the motor wire connectors. The meter should read between 700 Ω and 750 Ω .
4. If the reading is not within this range, remove and replace the door latch assembly.

Door Latch Positions

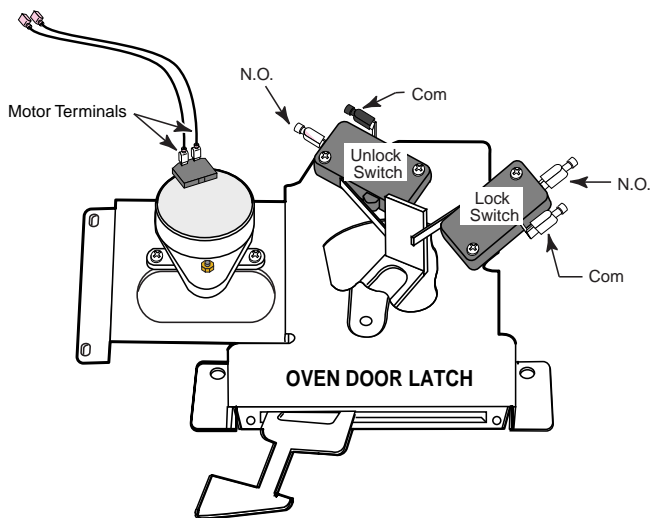
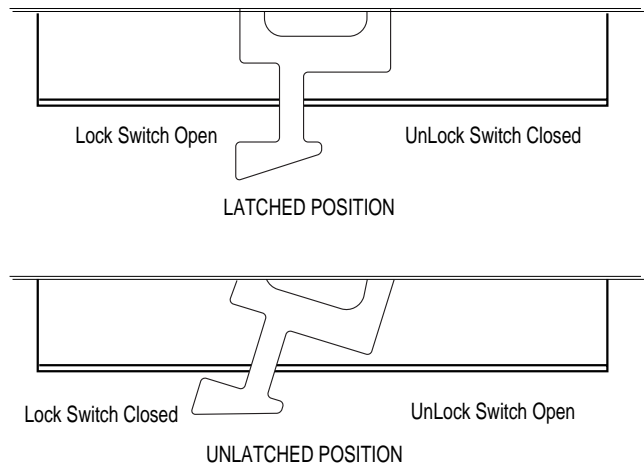

Latch Position	Lock Switch	Unlock Switch
Unlatched	Yes	No
Latched	No	Yes

THE HIDDEN BAKE ELEMENT ("C" MODELS ONLY)

Refer to page 2-4 to access the bake element.

1. With no power applied, remove the wires from the terminals of the hidden bake element.
2. Set the ohmmeter to the R x 1 scale.
3. Touch the ohmmeter leads to the bake element terminals. The meter should indicate 24 Ω .
4. If the reading is not correct, remove and replace the bake element.

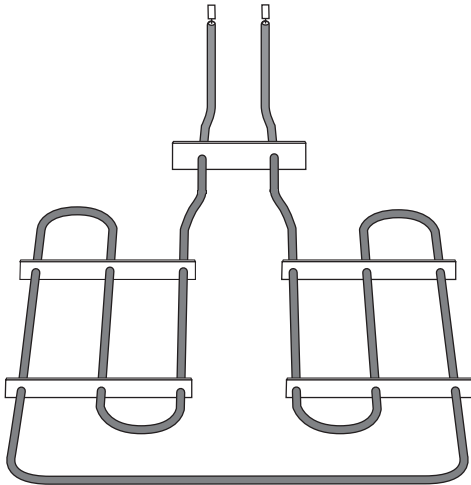

THE BROIL ELEMENT

Refer to page 2-2 to access the broil element.

1. With no power applied, remove the wires from the terminals of the broil element.
2. Set the ohmmeter to the R x 1 scale.
3. Touch the ohmmeter leads to the broil element terminals. The meter should indicate 15 Ω .
4. If the reading is not correct, remove and replace the broil element.

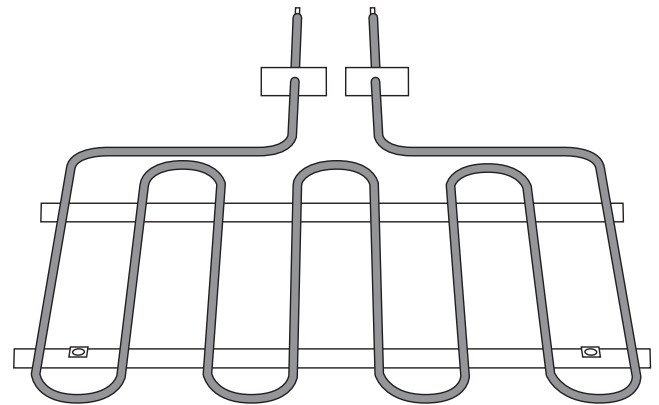

THE CONVECTION BAKE ELEMENT

Refer to page 2-7 to access the convection bake element.

1. With no power applied, remove the wires from the terminals of the convection bake element.
2. Set the ohmmeter to the R x 1 scale.
3. Touch the ohmmeter leads to the convection bake element terminals. The meter should indicate 18 Ω .
4. If the reading is not correct, remove and replace the convection bake element.

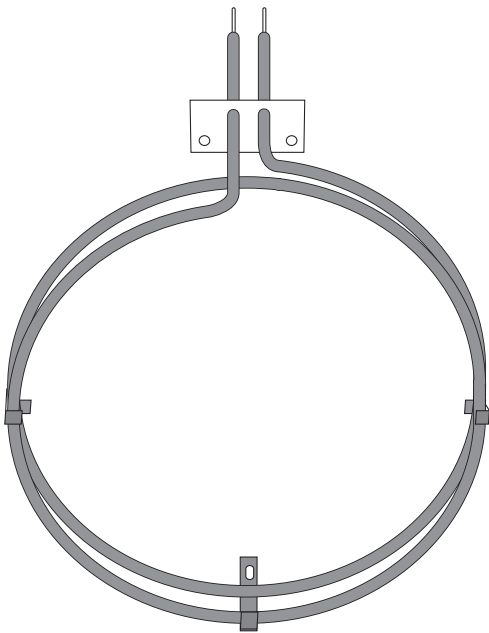

THE HI-TEMP CUTOUT

The hi-temp cutout contacts open at or above 350°F $\pm 8^\circ$, and are manually reset by pressing the reset button.

Refer to page 2-18 to access the hi-temp cutout.

1. With no power applied, remove the wires from the terminals of the hi-temp cutout.
2. Set the ohmmeter to the R x 1 scale.
3. Touch the ohmmeter leads to the terminals. The meter should indicate continuity.
4. If the reading is not correct, remove and replace the hi-temp cutout.

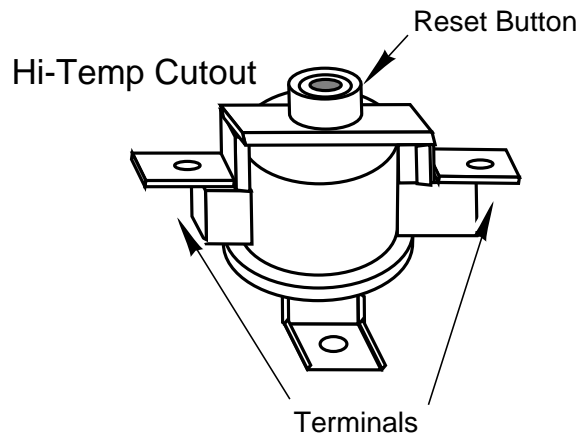

Fault Codes

CODE	FAULT DETECTION
F10	Power board incompatibility
F11	Communication error with power board
F12	Vcc lift-off (power board)
F13	Power board not calibrated
F14	Display board EEPROM error
F19	Misc. power board error
F20	Upper oven cancel key shorted high
F21	Lower oven cancel key shorted high
F22	Upper oven cancel key shorted low
F23	Lower oven cancel key shorted low
F24	Key stuck
F25	Multiple keys stuck
F30	Upper oven sensor shorted
F31	Upper oven sensor open
F32	Upper oven over temperature while cleaning
F33	Upper oven over temperature while cooking
F34	Upper oven cooling fan not operating
F40	Upper meat probe shorted
F50	Upper door signal shorted low
F51	Upper door stuck locked
F52	Upper oven door position error (locked and open)
F53	Upper door stuck locked
F54	Upper latch input shorted
F60	Lower oven sensor shorted
F61	Lower oven sensor open
F62	Lower oven over temperature while cleaning
F63	Lower oven over temperature while cooking
F64	Lower oven cooling fan not operating
F70	Lower meat probe shorted
F80	Lower door signal shorted low
F81	Lower door stuck locked
F82	Lower oven door position error (locked and open)
F83	Lower door stuck locked
F84	Lower latch input shorted

“C” OVEN

Current Flow Charts

Oven Mode Time Charts

Mode	Seconds On Bake Element	Seconds On Broil Element	Seconds On Convection Element
Bake Preheat	25	35	0
Bake Mode	56	4	0
Proof Preheat	10	10	0
Proof Mode	10	10	0
Roast Preheat	25	35	0
Roast Mode	48	12	0
Broil Preheat	0	60	0
Broil Mode	0	50	0
Convection Preheat	0	0	60
Convection Mode	0	0	60
Dehydrate Preheat	0	0	30
Dehydrate Mode	0	0	30
Convection Bake Preheat	35	25	0
Convection Bake Mode	56	4	0
Convection Roast Preheat	0	30	30
Convection Roast Mode	30	0	30
Convection Broil Preheat	0	60	0
Convection Broil Mode	0	60	0
CL/Preheat 240 Volts	45	37	0
CL Mode 240 Volts	45	37	0
CL Preheat 208 Volts	60	60	0
CL Mode 208 Volts	60	60	0

“C” OVEN Sequence of Events

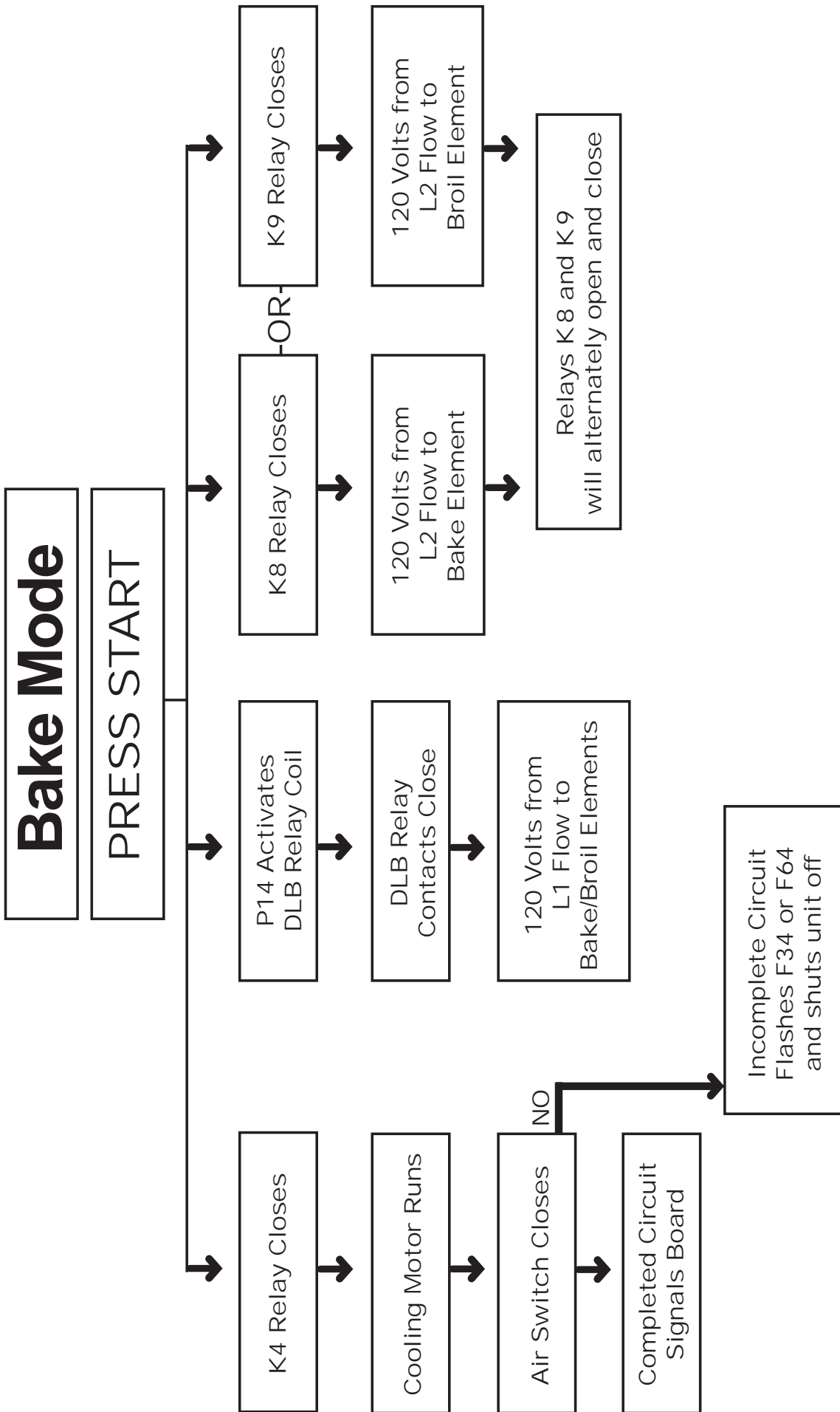

Bake Pre-Heat

Sequence Of Events:

- 1) K4, K8, K9 relays close.
- 2) K4 relay energizes both cooling motors; airflow from cooling motor closes the “air switch” contacts, the completed “air switch” circuit signals the board (signal voltage), note: if the air switch circuit is not completed within 40 seconds, the board will interpret an cooling fan fault and display an F34 error code for the upper oven, and an F64 error code for the lower oven.
- 3) Pin header P14 on the relay board sends 24 VDC to the double-line break relay (DLB) coil, when the coil is energized; the DLB contacts close. Current flows from L1 to one leg of the bake, broil and convection elements.
- 4) Bake relay K8 and broil relay K9 alternately open and close and send current from L2 to the other leg of the bake and broil elements. The bake element is on for 25 seconds, and the broil element is on for 35 seconds during each 1 minute cycle,

Bake Mode

Sequence Of Events:

- 1) K4, K8, K9 relays close.
- 2) K4 relay energizes both cooling motors; airflow from cooling motor closes the “air switch” contacts. The completed “air switch” circuit signals the board (signal voltage). Note: if the air switch circuit is not completed within 40 seconds, the board will interpret a cooling fan fault and display an F34 error code for the upper oven, and an F64 error code for the lower oven.
- 3) Pin header P14 on the relay board sends 24 VDC to the double line break relay (DLB) coil when the coil is energized; the DLB contacts close. Current flows from L1 to one leg of the bake, broil and convection elements.
- 4) Bake relay K8 and broil relay K9 alternately open and close and send current from L2 to the other leg of the bake and broil elements. The

Bake element is on for 56 seconds, and the broil element is on for 4 seconds during each 1-minute cycle.

“C” OVEN Sequence of Events

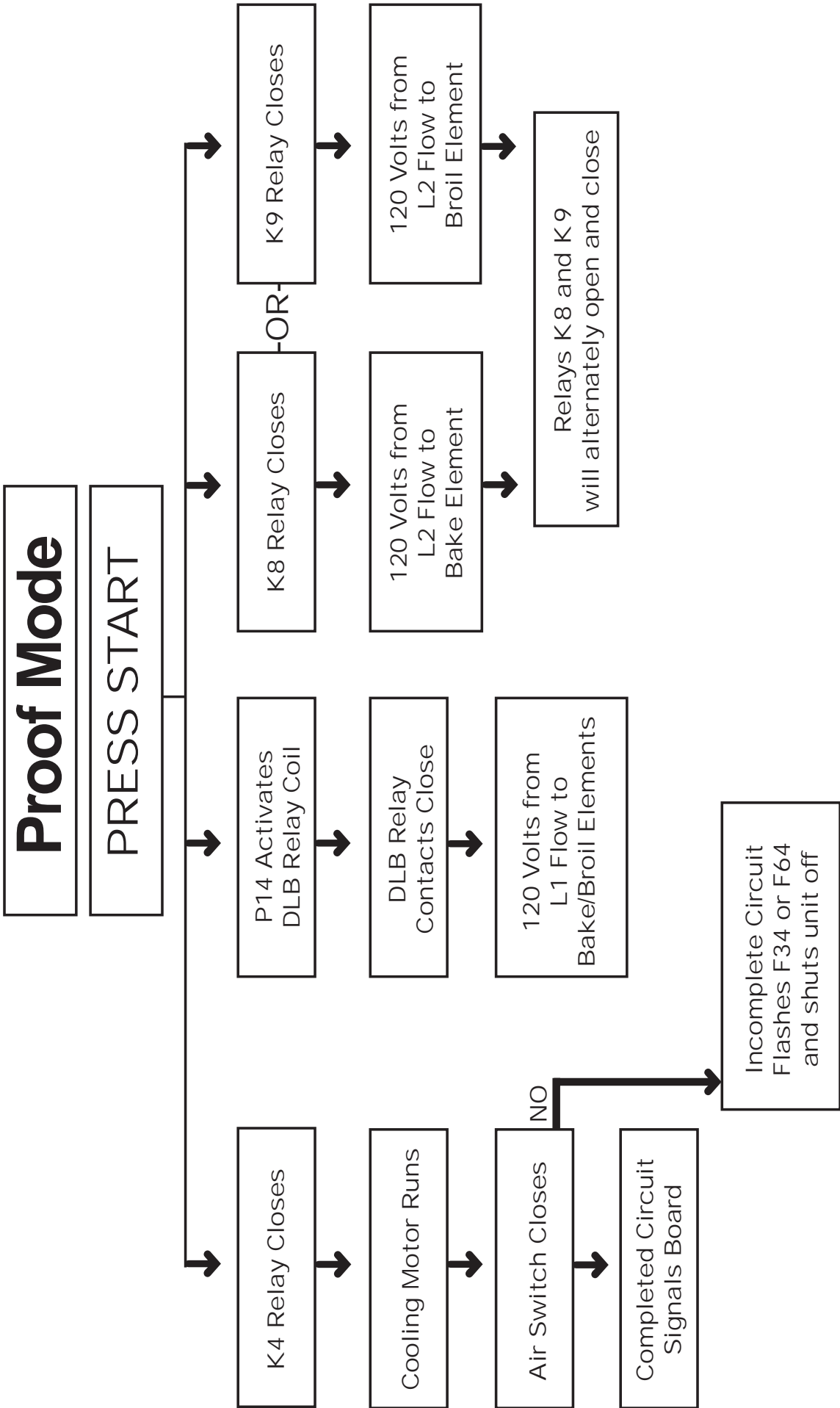

Proof Pre-Heat

Proof Mode

Sequence Of Events:

- 1) K4, K8, K9 relays close.
- 2) K4 relay energizes both cooling motors; airflow from cooling motor closes the “air switch” contacts the completed “air switch” circuit signals the board (signal voltage). Note: if the air switch circuit is not completed within 40 seconds, the board will interpret an cooling fan fault and display an F34 error code for the upper oven, and an F64 error code for the lower oven.
- 3) Pin header P14 on the relay board sends 24 VDC To the double line break relay {DLB) coil when the coil is energized; the DLB contacts close. Current flows from L1 to one leg of the bake, broil and convection elements.
- 4) Bake relay K8 and broil relay K9 alternately open and close and send current from l2 to the other leg of the bake and broil elements. The bake element is on for 10 seconds, and the broil element is on for 10 seconds during each 1-minute cycle.

“C” OVEN Sequence of Events

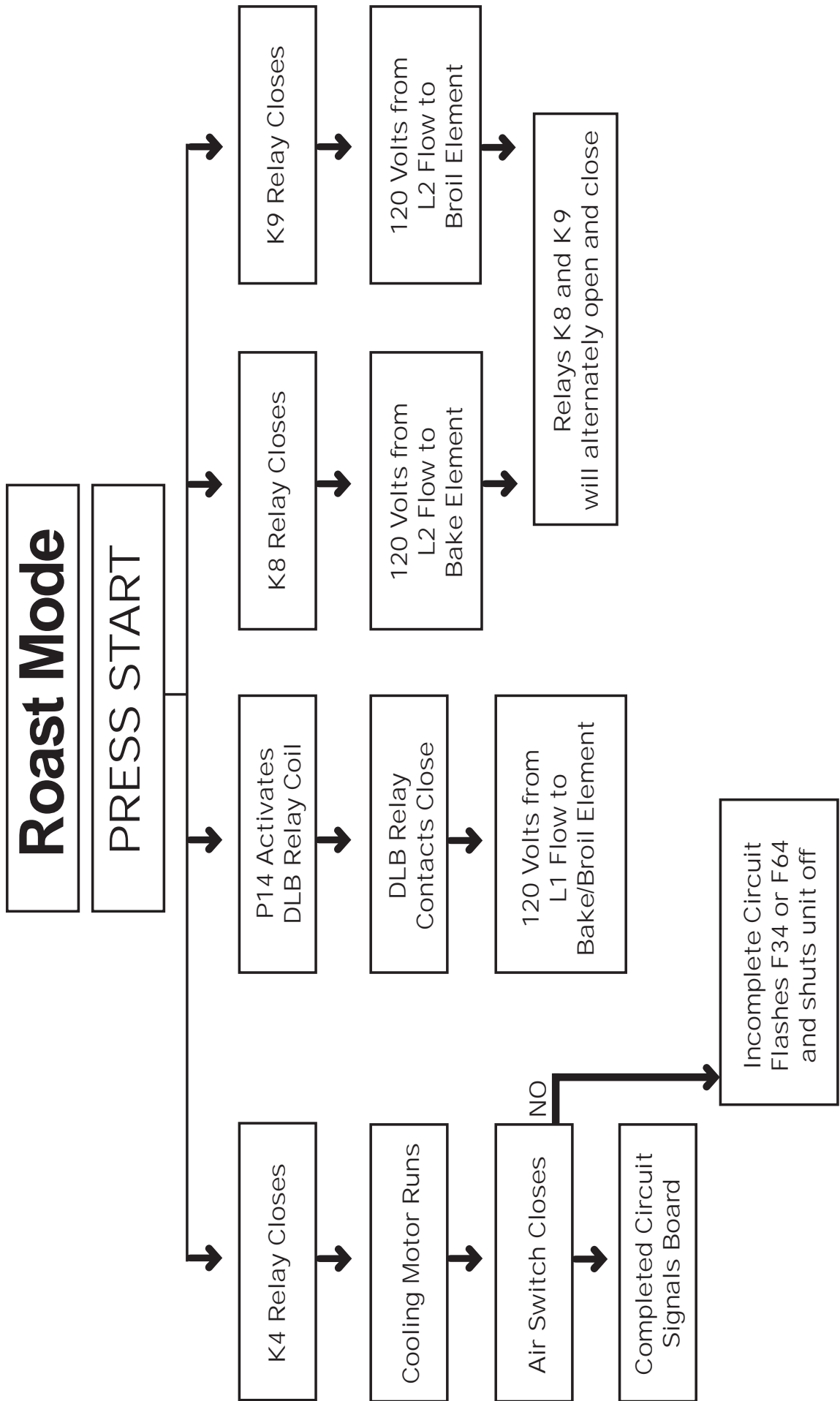

Roast Pre-Heat Mode

Sequence Of Events:

- 1) K4, K8, K9 relays close.
- 2) K4 relay energizes both cooling motors; airflow from cooling motor closes the “air switch” contacts. The completed “air switch” circuit signals the board (signal voltage), note: if the air switch circuit is not completed within 40 seconds, the board will interpret an cooling fan fault and display an F34 error code for the upper oven, and an F64 error code for the lower oven.
- 3) Pin header P14 on the relay board sends VDC to the double line break relay (DLB) coil, when the coil is energized; the DLB contacts close, current flows from L1 to one leg of the bake, broil and convection elements,
- 4) Bake relay K8 and broil relay K9 alternately open and close and send current from L2 to the other leg of the bake and broil elements, the bake element is on for 25 seconds, and the broil element is on for 35 during each 1minute cycle.

Roast Mode

Sequence Of Events:

- 1) K4, K8, K9 relays close.
- 2) K4 relay energizes both cooling motors; airflow from cooling motor closes the “air switch” contacts, the completed “air switch” circuit signals the board (signal voltage).

Note: if the air switch circuit is not completed, within 40 seconds, the board will interpret a cooling fan fault and display an F34 error code.

For the upper oven, and an F64 error code for the lower oven,

- 3) Pin Header P14 on the relay board sends 24 VDC to the double line break relay (DLB) coil. When the coil is energized; the DLB contacts close, current flows from L1 to one leg of the bake, broil, and convection elements.
- 4) Bake relay K8 and broil relay K9 alternately open and close and send current from L2 to the other leg of the bake and broil elements, this completes the 240-volt circuit, the bake element is on for 48 seconds, and the broil element is on for 12 seconds during each 1-minute cycle.

“C” OVEN Sequence of Events

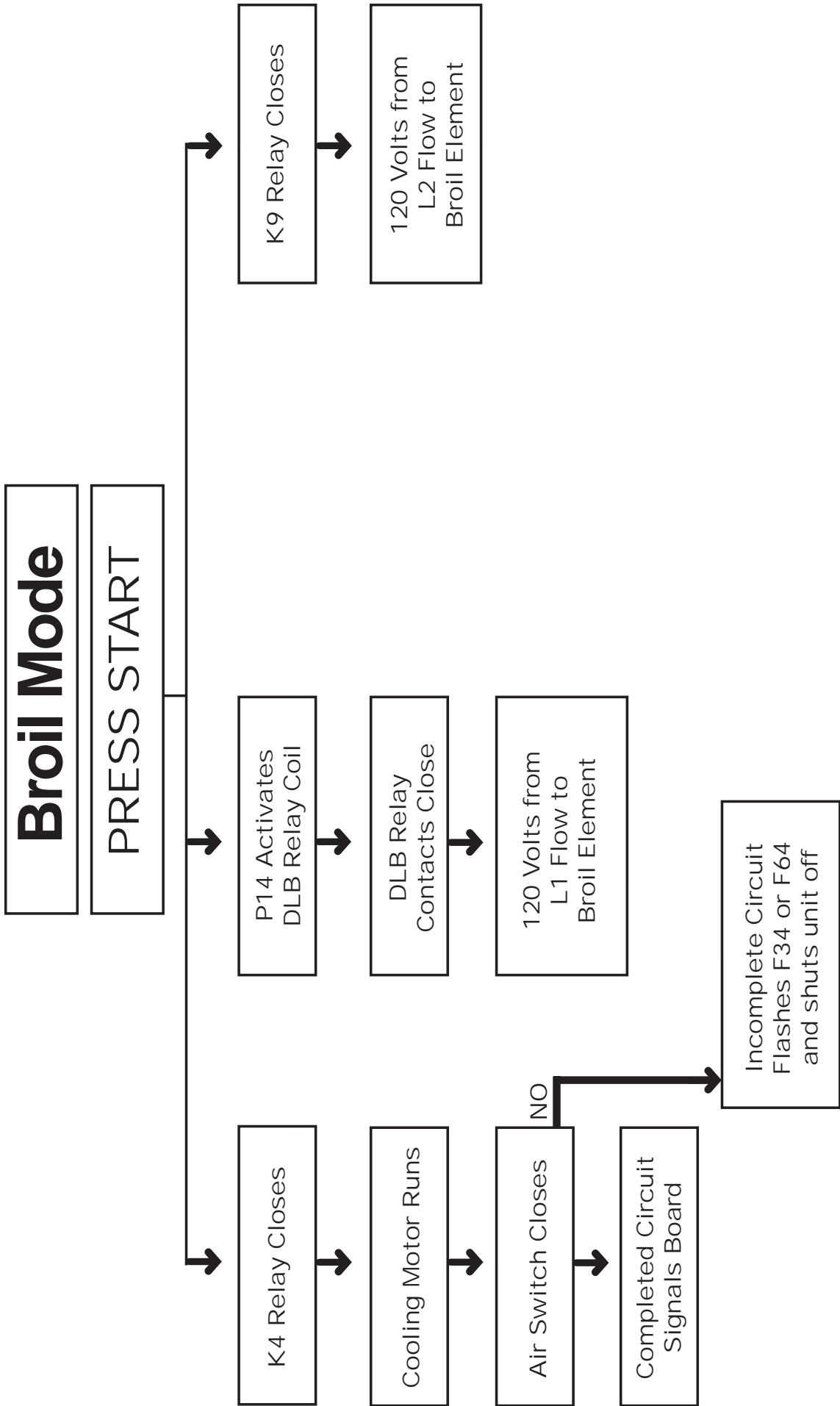

Broil Pre-Heat

Broil Mode

Sequence Of Events:

- 1) K4, K9 relays close.
- 2) K4 relay energizes both cooling motors; airflow from cooling motor closes the “air switch” contacts, the completed “air switch” circuit signals the board (signal voltage). Note: if the air switch circuit is not completed within 40 seconds, the board will interpret an cooling fan fault and display an F34 error code for the upper oven, and an F64 error code for the lower oven.
- 3) Pin header P14 on the relay board sends 24 VDC to the double line break relay (DLB) coil, when the coil is energized, the DLB contacts close.

Current flows from L1 to one leg of the bake, broil, and convection element.

- 4) Broil relay K9 closes and send current from L2 to the other leg of the broil element. The broil element is on for 60 seconds during each 1-minute cycle.

“C” OVEN Sequence of Events

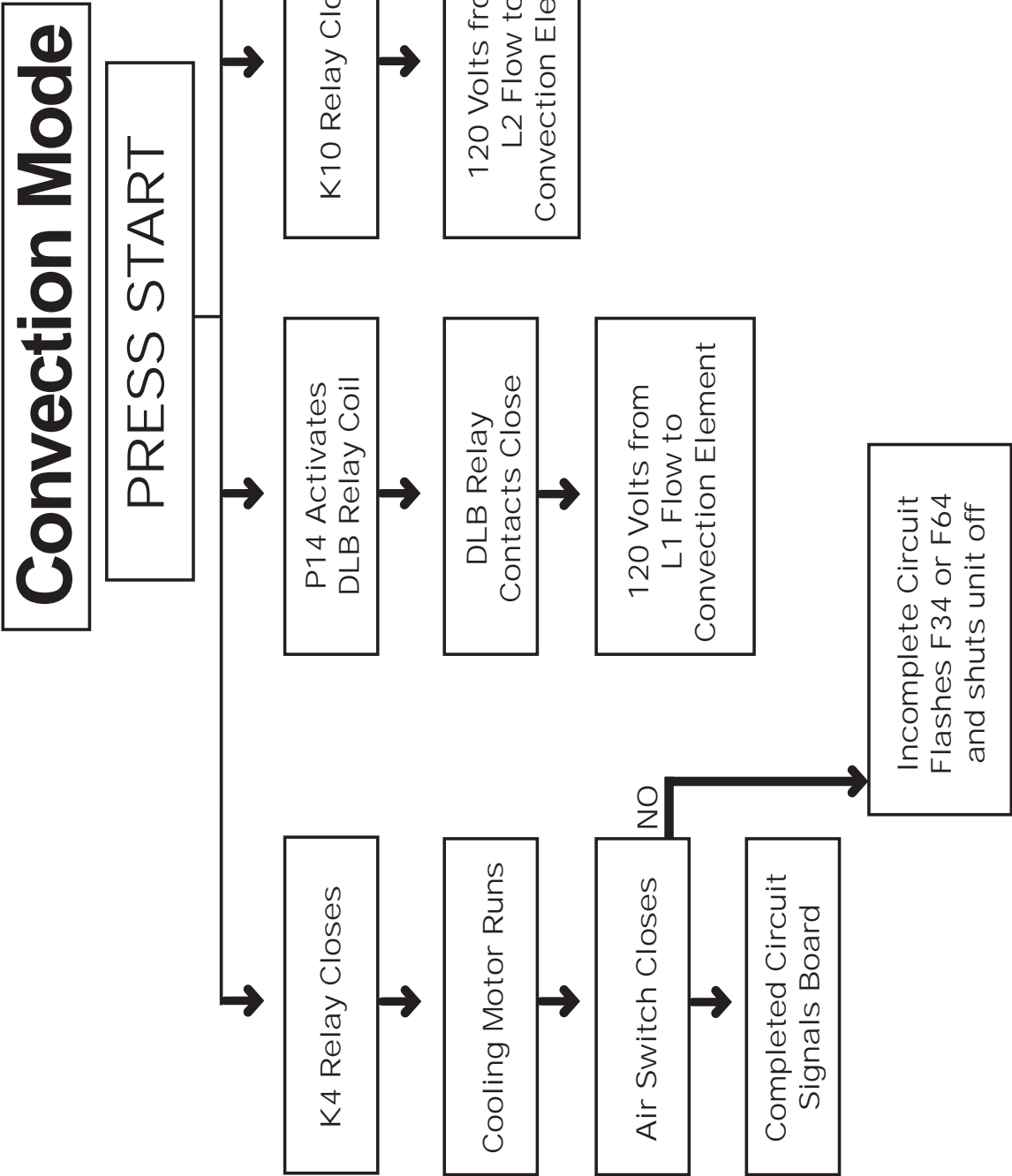

Convection Pre-Heat Mode

Convection Mode

Sequence of events:

- 1) K4, K10, K11 relays close.
- 2) K4 relay energizes both cooling motors; airflow from cooling motor closes the “air switch” contacts. The completed “air switch” circuit signals the board (signal voltage). Note: if the air switch circuit is not completed within 40 seconds, the board will interpret an cooling fan fault and display an F34 error code for the upper oven, and an F64 error code for the lower oven.
- 3) K11 relay closes and activates the convection motor. Note: the convection motor will stop when the oven door is opened during any convection mode.
- 4) Pin header P14 on the relay board sends 24 VDC to the double line break relay (DLB) coil. When the coil is energized; the DLB contacts close. Current flows from L1 to one leg of the bake, broil, and convection element
- 5) Convection relay K10 closes and sends current from L2 to the other leg of the convection element. The convection element is on for 60 seconds during each 1-minute cycle.

“C” OVEN Sequence of Events

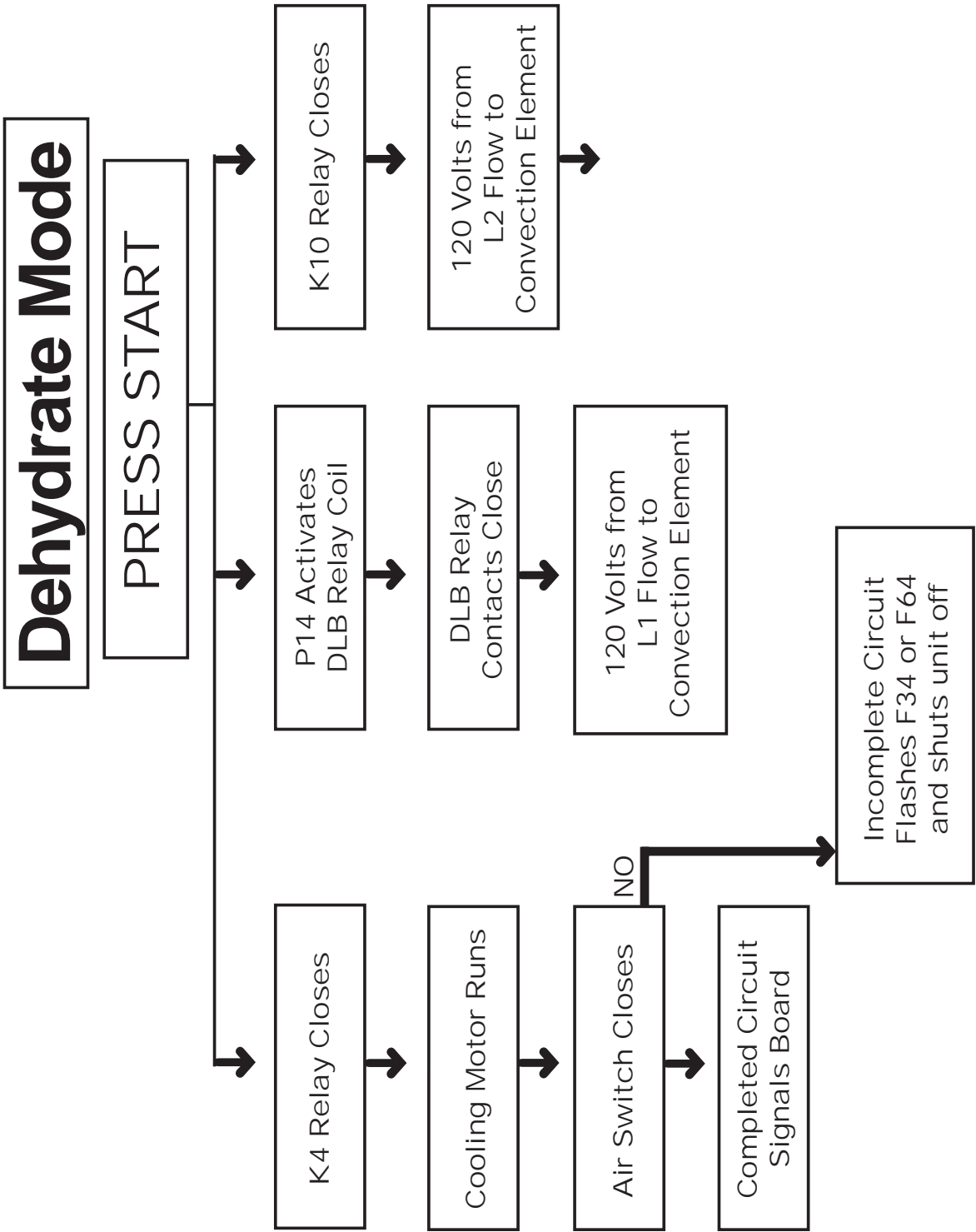

Dehydrate Pre-Heat

Dehydrate Mode

Sequence Of Events:

- 1) K4, K10, K11 relays close.
- 2) K4 relay energizes both cooling motors; airflow from cooling motor closes the “air switch” contacts, the completed “air switch” circuit signals the board {signal voltage}.

Note: if the air switch circuit is not completed within 40 seconds, the board will interpret a cooling fan fault and display an F34 error code for the upper oven, and an F64 error code for the lower oven.

- 3) Pin header P14 on the relay board sends 24 VDC To the double line break relay (DLB) coil. When the coil is energized; the DLB contacts close. Current flows from L1 to one leg of the bake, broil and convection elements.
- 4) Convection relay K10 closes and sends current from L2 to the other leg of the convection element, the convection element is on for 30 seconds during each 1-minute cycle.

“C” OVEN Sequence of Events

Convection Bake Mode

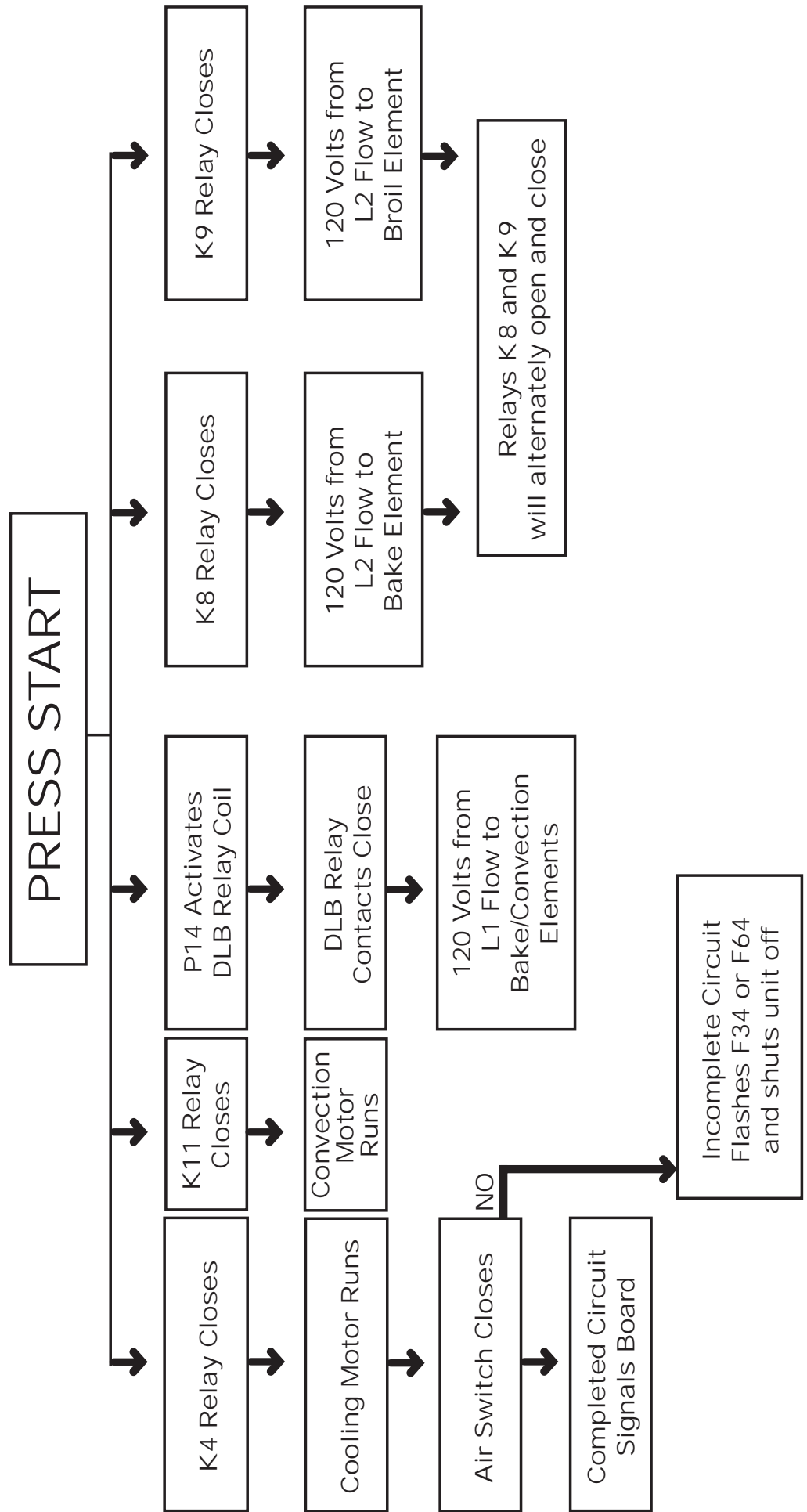

Convection Bake Pre-Heat Mode

Sequence Of Events:

- 1) K4, K8, K9, K11 relays close.
- 2) K4 relay energizes both cooling motors; airflow from cooling motor closes the “air switch” contacts. The completed “air switch” circuit signals the board (signal voltage).

Note: if the air switch circuit is not completed within 40 seconds, the board will interpret a cooling fan fault and display an F34 error code for the upper oven, and an F64 error code for the lower oven.

- 3) K11 relay closes and activates the convection motor. Note: The convection motor will stop when the oven door is opened during any convection mode.
- 4) Pin header P14 on the relay board sends 24 VDC to the double line break relay (DLB) coil is energized; the DLB contacts close. Current flows from L1 to one leg of the bake, broil, and convection elements.
- 5) Bake relay K8 and broil relay K9 alternately open and close and send current from L2 to the other leg of the bake and broil elements. The bake element is on for 35 seconds, and the broil element is on for 25 seconds during each 1-minute cycle.

Convection Bake Mode

Sequence Of Events:

- 1) K8, K9, K11 relays close.
- 2) K4 relay energizes both cooling motors; airflow from cooling motor closes the “air switch” contacts. The completed “air switch” circuit signals the board (signal voltage). Note: If the air switch circuit /s not completed within 40 seconds, the board will interpret a cooling fan fault and display an F34 error code for the upper oven, and an F64 error code for the lower oven.
- 3) K11 relay closes and activates the convection motor. Note: The convection motor will stop when the oven door is opened during any convection mode.
- 4) Pin header P14 on the relay board sends 24 VDC to the double line break relay (DLB) coil. When the coil is energized; the DLB contacts close. Current flows from L1 to one leg of the bake, broil, and convection elements.
- 5) Bake relay K8 and broil relay K9 alternately open and close and send current from L2 to the other leg of the bake and broil elements the bake element is on for 56 seconds, and the broil element is on for 4 seconds during each 1-minute cycle.

“C” OVEN Sequence of Events

Convection Roast Mode

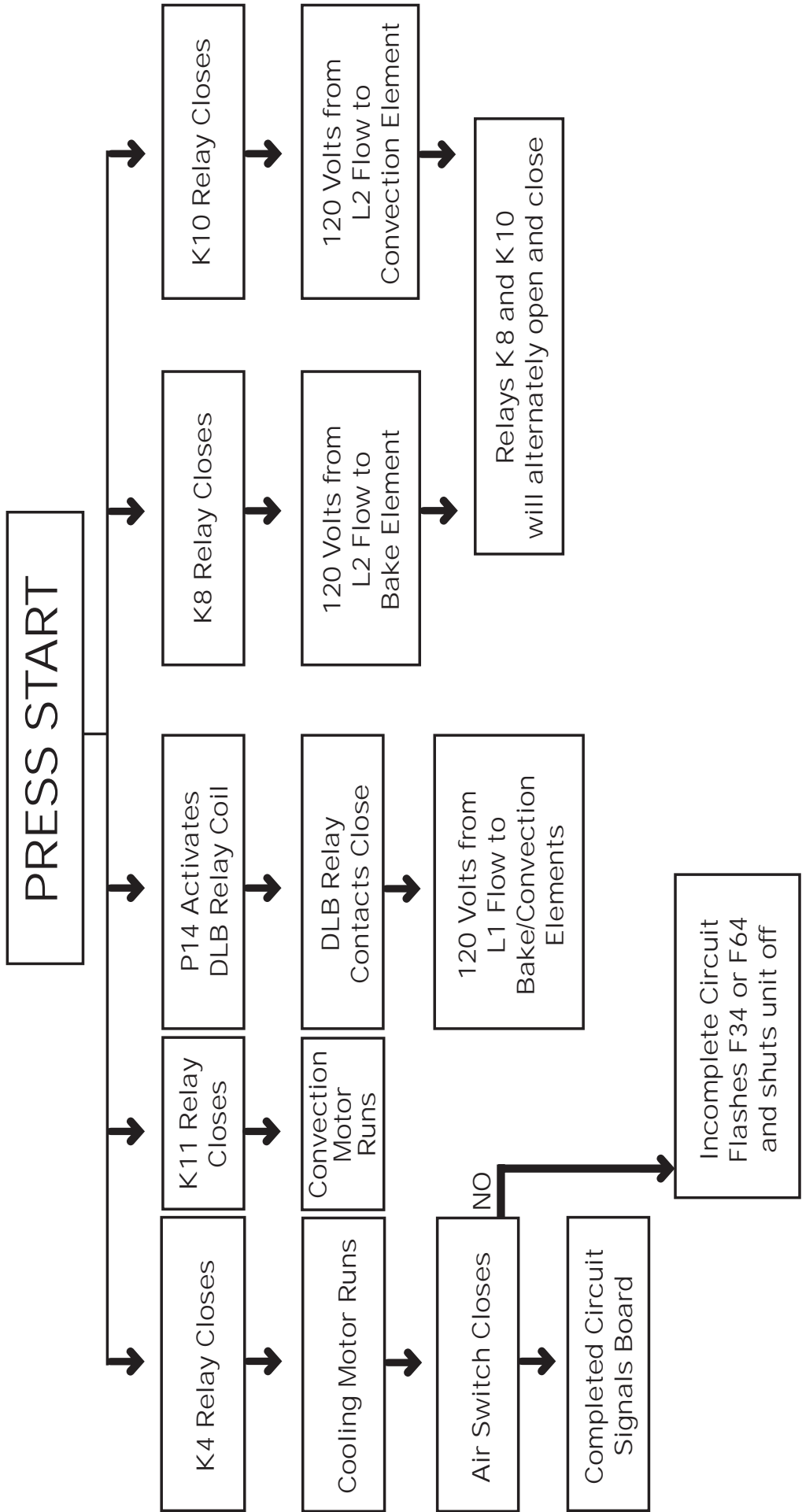

Convection Roast Pre-Heat Mode

Sequence Of Events:

- 1) K4, K9, K10, K11 relays close.
- 2) K4 relay energizes both cooling motors; air flow from cooling motor closes the “air switch” contacts. The completed “air switch” circuit signals the board (signal voltage).

Note: if the air switch circuit is not completed within 40 seconds, the board will interpret a cooling fan fault and display an f34 error code for the upper oven, and an F64 error code for the lower oven.

- 3) K11 relay closes and activates the convection motor. Note: the convection motor will stop when the oven door is opened during any convection mode.
- 4) Pin header P14 on the relay board sends 24 VDC to the double line break relay (DLB) coil. When the coil is energized; the DLB contacts close. Current flows from L1 to one leg of the bake, broil, and convection elements.
- 5) Convection relay K10 and broil relay K9 alternately open and close and send current from L2 to the other leg of the convection and broil elements, the convection element is on for 30 seconds, and the broil element is on for 30 seconds during each 1-minute cycle.

Convection Roast Mode

Sequence Of Events;

- 1) K4, K8, K10, K11 relays close.
- 2) K4 relay energizes both cooling motors; airflow from cooling motor closes the “air switch” contacts. The completed “air switch” circuit signals the board (signal voltage). Note if the air switch circuit is not completed within 40 seconds, the board will interpret a cooling fan fault and display an F34 ERROR CODE FOR THE UPPER OVEN, AND AN F64 error code for the lower oven.
- 3) K11 relay closes and activates the convection motor. Note: the convection motor will stop when the oven door is opened during any convection mode.
- 4) Pin header P14 on the relay board sends 24VDC to the double line break relay (DLB) coil when the coil is energized; the DLB contacts close. Current flows from L1 to one leg of the bake, broil, and convection elements.
- 5) Bake relay K8 and convection relay K10 alternately open and close and send current from L2 to the other leg of the bake and convection elements. The bake element is on for 30 seconds, and the convection element is on for 30 seconds during each 1-minute cycle.

“C” OVEN Sequence of Events

Convection Broil Mode

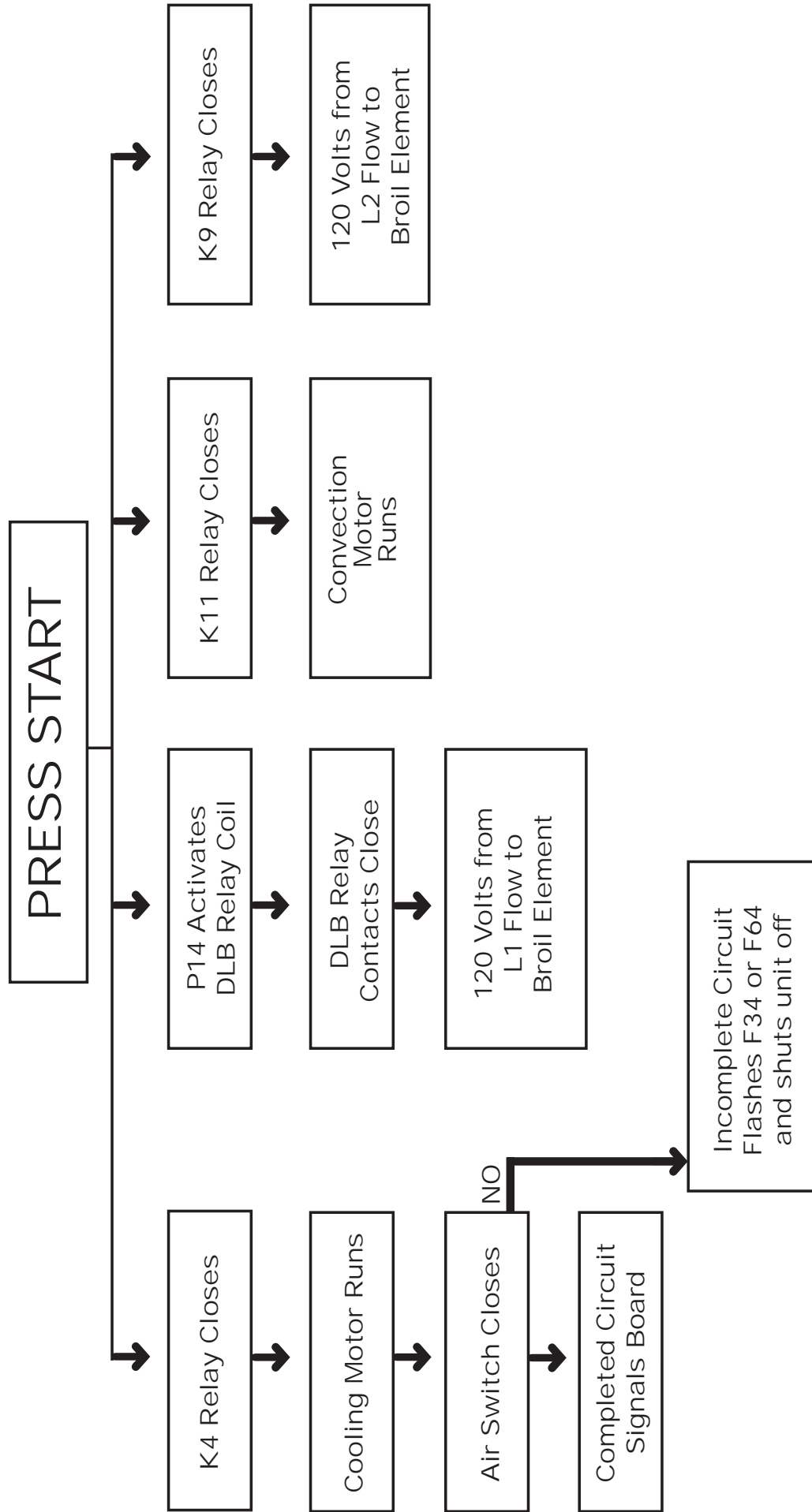

Convection Broil

Pre-Heat Mode

Convection Broil Mode

Sequence Of Events:

- 1) K4, K9, K11 relays close.
- 2) K4 relay energizes both cooling motors; airflow from cooling motor closes the “air switch” contacts. The completed “air switch” circuit signals the board (signal voltage). Note: if the air switch circuit is not completed within 40 seconds, the board will interpret a cooling fan fault and display an F34 error code for the upper oven, and an F64 error code for the lower oven.
- 3) K11 relay closes and activates the convection motor. Note: The convection motor will stop when the oven door is opened during any convection mode.
- 4) Pin header P14 on the relay board sends 24 VDC to the double line break relay (DLB) coil. When the coil is energized, the DLB contacts close. Current flows from L1 to one leg of the bake, broil, and convection elements.
- 5) Broil relay K9 closes and sends current from L2 to the other leg of the broil element. The broil element is on for 60 seconds during each 1-minute cycle.

“C” OVEN Sequence of Events

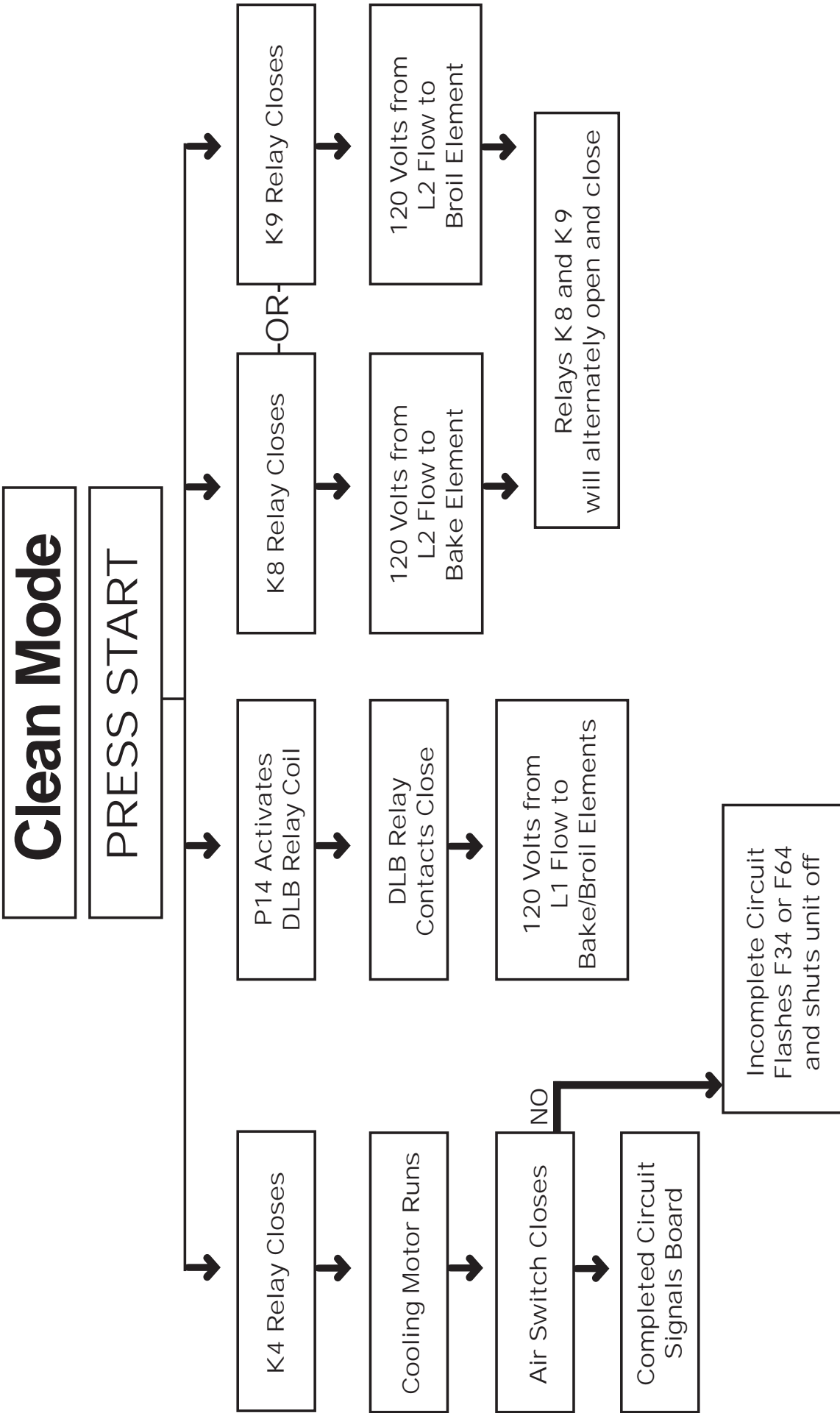

Clean Pre-Heat Mode

Sequence Of Events:

- 1) K4, K8, K9 relays close.
- 2) K4 relay energizes both cooling motors; airflow from cooling motor closes the “air switch” contacts. The completed “air switch” circuit

Signals the board {signal voltage). Note: if the air switch circuit is not completed within 40 seconds, the board will interpret a cooling fan fault and display an F34 error code for the upper oven, and an F64 error code for the lower oven.

- 3) Pin header P14 on the relay board sends 24 VDC to the double line break relay (DLB) coil. When the coil is energized, the DLB contacts close. Current flows from L1 to one leg of the bake, broil and convection elements.
- 4) Bake relay K8 and broil relay K9 alternately open and close and send current from L2 to the other leg of the bake and broil elements. The bake element is on for 10 seconds, and the broil element is on for 50 seconds during each 1-minute cycle.

Clean Mode

Sequence Of Event:

- 1) K4, K8, K9 relays close.
- 2) K4 relay energizes both cooling motors; airflow from cooling motor closes the “air switch” contacts. The completed “air switch” circuit

Signals the board {signal voltage). Note: if the air switch circuit is not completed within 40 seconds, the board will interpret an

Cooling fan fault and display an f34 error code for the upper oven, and an F64 error code for the lower oven.
- 3) Pin header P14 on the relay board sends 24 VDC to the double line break relay {DLB) coil. When the coil is energized; the DLB contacts close. Current flows from L1 to one leg of the bake, broil and convection elements.
- 4) Bake relay K8 and broil relay K9 alternately open and close and send current from L2 to the other leg of the bake and broil elements. The bake element is on for 45 seconds, and the broil element is on for 37 seconds during each 1-minute cycle.

Halogen Light Circuit

The halogen light transformer is a “center tap” step down transformer with a primary and a center tap secondary winding. The primary winding receives 120 volts AC and steps down the secondary winding to 12 volts AC.

Terminals #6, #8 and #10 have a 12-volt AC potential. See illustration below.

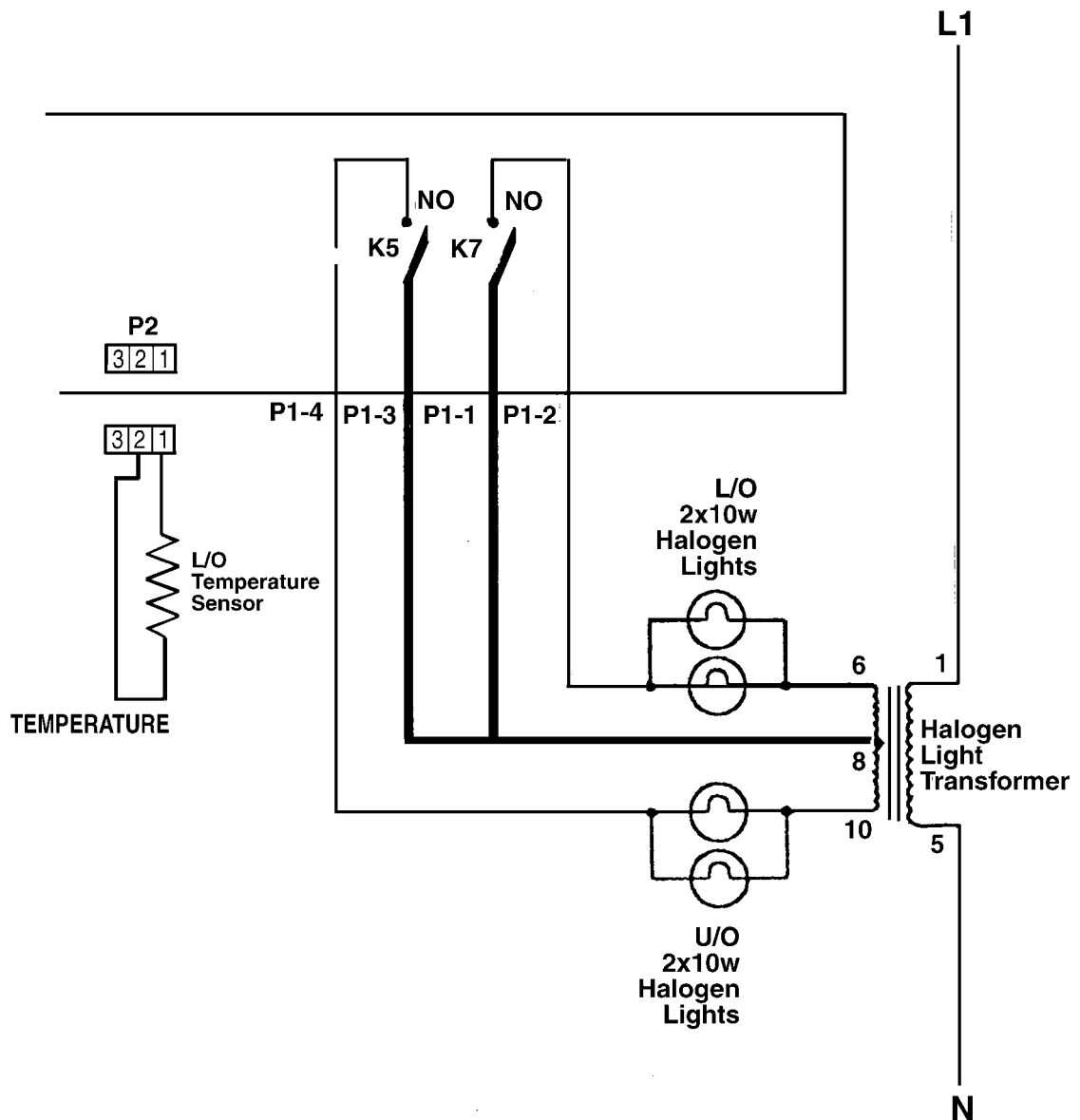

When Relay K6 (upper oven light) or K7 (lower oven light) are activated, the circuit is completed to neutral (terminal #8) and the oven lights come on.

