



**CONSUMER SERVICES TECHNICAL  
EDUCATION GROUP PRESENTS**

**KR-31**

**30" FREESTANDING  
SELF-CLEANING  
ELECTRIC RANGE**



**JOB AID  
Part No. 8178042**



# FORWARD

This Whirlpool Job Aid, “30” Freestanding Self-Cleaning Electric Range,” (Part No. 8178042), provides the technician with information on the operation and service of the Freestanding Self-Cleaning Electric Range. It is to be used as a training Job Aid and Service Manual. For specific information on the model being serviced, refer to the “Use and Care Guide,” or “Tech Sheet” provided with the electric range.

The Wiring Diagrams and Strip Circuits used in this Job Aid are typical and should be used for training purposes only. Always use the Wiring Diagram supplied with the product when servicing the unit.

## GOALS AND OBJECTIVES

The goal of this Job Aid is to provide detailed information that will enable the service technician to properly diagnose malfunctions and repair the Whirlpool 30” Freestanding Self-Cleaning Electric Range.

The objectives of this Job Aid are to:

- Understand and follow proper safety precautions.
- Successfully troubleshoot and diagnose malfunctions.
- Successfully perform necessary repairs.
- Successfully return the electric range to its proper operational status.

WHIRLPOOL CORPORATION assumes no responsibility for any repairs made on our products by anyone other than Authorized Service Technicians.

# TABLE OF CONTENTS

Page

<b>GENERAL</b> .....	1-1
Important Safety Information .....	1-1
Whirlpool Model & Serial Number Designations .....	1-2
Model & Serial Number Label And Tech Sheet Locations .....	1-3
Specifications .....	1-4
Whirlpool Electric Range Warranty .....	1-12
<b>THEORY OF OPERATION</b> .....	2-1
AccuBake VS. AccuBake Duo Cooking Systems .....	2-1
AccuSimmer Basic Operation .....	2-3
Keep Warm Element.....	2-6
Warming Drawer .....	2-7
Soft Close Door .....	2-8
<b>COMPONENT ACCESS</b> .....	3-1
Component Locations .....	3-1
Removing A Single Element Infinite Switch .....	3-2
Removing The Normal Burner/AccuSimmer Switch .....	3-3
Removing The Dual Element Infinite Switch .....	3-4
Removing The Keep Warm Switch .....	3-5
Removing An Indicator Light.....	3-6
Removing The Control Power Supply And The Electronic Oven Control .....	3-7
Removing An Element & Limiter And The Cooktop Glass Assembly .....	3-8
Removing The Hot Surface Indicators .....	3-10
Removing The Door Latch & The Door Switch .....	3-12
Removing The Broil & Bake Elements .....	3-14
Removing The Oven Light Socket Assembly .....	3-16
Removing The Latch Drive Assembly .....	3-17
Removing The Oven Temperature Sensors And The Thermal Fuse .....	3-18
Removing The Warming Drawer Element & Temperature Sensor .....	3-19
Removing The Oven Door .....	3-20
Removing The Oven Door Handle & Glass .....	3-22
Removing The Oven Door Gasket.....	3-24
Removing A Side Panel .....	3-25
<b>COMPONENT TESTING</b> .....	4-1
Door Switch .....	4-1
Warming Drawer Element.....	4-1
Bake Element .....	4-2
Broil Element .....	4-2
Latch Drive .....	4-3
Oven & Warming Drawer Temperature Sensors .....	4-3
Thermal Fuse .....	4-4
Single Element Infinite Switches .....	4-4
Dual Element Infinite Switch .....	4-5
Keep Warm Switch .....	4-6
Normal Burner/AccuSimmer Switch .....	4-7
Surface Elements & Limiters .....	4-8

	<b>Page</b>
<b>DIAGNOSIS &amp; TROUBLESHOOTING</b> .....	5-1
Failure / Error Display Codes—Tech Sheet 8522647 .....	5-1
<b>WIRING DIAGRAMS &amp; STRIP CIRCUITS</b> .....	6-1
Wiring Diagram .....	6-1
Strip Circuits .....	6-2
<b>TECH TIPS</b> .....	7-1
Duo Cooking System Flow Chart.....	7-1

# GENERAL

## IMPORTANT SAFETY INFORMATION

**Your safety and the safety of others is very important.**

Important safety messages have been provided in this Job Aid. Always read and obey all safety messages.



This is the safety alert symbol. This symbol alerts you to hazards that can kill or hurt you and others.

All safety messages will be preceded by the safety alert symbol and the word **“WARNING.”**

All safety messages will identify the hazard, tell you how to reduce the chance of injury, and tell you what can happen if the instructions are not followed.

### **WARNING**

#### **ELECTRICAL SHOCK HAZARD**

Disconnect power before servicing.  
Replace all panels before operating.  
Failure to do so could result in death or electrical shock.

### **WARNING**

#### **PERSONAL INJURY HAZARD**

To prevent tipping, install range anti-tip bracket.  
Save the installation instructions. If the range is moved to a new location, the anti-tip bracket must be removed and reinstalled in the new location.  
Failure to follow these instructions could result in serious injury.

### **ELECTROSTATIC DISCHARGE (ESD) SENSITIVE ELECTRONICS**

ESD problems are present everywhere. ESD may damage or weaken the electronic control assembly. The new control assembly may appear to work well after repair is finished, but failure may occur at a later date due to ESD stress.

- Use an antistatic wrist strap. Connect the wrist strap to a green ground connection point or unpainted metal in the appliance; or touch your finger repeatedly to a green ground connection point or unpainted metal in the appliance.
- Before removing the part from its package, touch the antistatic bag to a green ground connection point or unpainted metal in the appliance.
- Avoid touching electronic parts or terminal contacts. Handle the electronic control assembly by the edges only.
- When repackaging the failed electronic control assembly in an antistatic bag, observe the above instructions.

# WHIRLPOOL MODEL & SERIAL NUMBER DESIGNATIONS

## MODEL NUMBER

MODEL NUMBER	R	F	3	6	4	P	X	K	W
INTERNATIONAL SALES IND. OR MARKETING CHANNEL IF PRESENT									
<b>PRODUCT GROUP:</b> R = ELECTRIC RANGES S = GAS RANGES G = WHIRLPOOL GOLD									
<b>PRODUCT IDENTIFICATION:</b> A = ACCESSORY      K = KITS B = BUILT-IN        M = MV COMBO C = COOKTOP        S = SET-IN E = EYE-LEVEL      W = SLIDE-IN GAS F = FREESTANDING   Y = SLIDE-IN ELECTRIC H = HOODS									
<b>MODEL SIZE:</b> 0 = 20" OR 24" FREESTANDING 1 = 30" IMPERIAL SERIES FREESTANDING (1996 & LATER) 2 = 30" FREESTANDING (1996 & LATER) 3 = 30" FREESTANDING 4 = 40" FREESTANDING 5 = 36" FREESTANDING 6 = 30" SET-IN RANGES									
<b>OVEN TYPES:</b> 0 THRU 3 = STANDARD PORCELAIN 2 THRU 5 = CONTINUOUS CLEAN (BEFORE 1996) 4 THRU 9 = PYROLYTIC SELF-CLEAN									
<b>FEATURE / VARIATIONS:</b> ELECTRIC 0, 1, 2, 5, 7 = COIL ELEMENTS 4 = STANDARD PATTERN CERAMIC 6, 8, 9 = DELUXE PATTERN CERAMIC GAS 0, 1, 2, 3, 4, 6 = OPEN BURNER 5 & 7 = SEALED BURNER									
<b>DOOR TYPE:</b> B = SOLID BLACK GLASS L = LARGE WINDOW O = METAL OVEN DOOR P = STANDARD WINDOW GLASS									
<b>FEATURE CODE:</b> E = ELECTRONIC IGNITION (GAS ONLY) S = STANDING IGNITION (GAS ONLY) C = COLOR COORDINATED GLASS (BEFORE 1998) X = NOT DEFINED									
<b>YEAR OF INTRODUCTION:</b> H = 1999. J = 2000, K = 2001									
<b>COLOR CODE:</b> B = BLACK              W = WHITE              P = PANORAMIC N = ALMOND            Z = ALMOND ON ALMOND Q = WHITE ON WHITE    T = BISCUIT S = STAINLESS STEEL    V = BISCUIT W / BLACK DOOR / PANEL									

## SERIAL NUMBER

SERIAL NUMBER	R	K	49	15548
MANUFACTURING SITE R = TULSA, OKLAHOMA				
YEAR OF PRODUCTION: K = 2000, L = 2001, M = 2002				
WEEK OF PRODUCTION: 49th WEEK				
PRODUCT SEQUENCE NUMBER				

# MODEL & SERIAL NUMBER LABEL AND TECH SHEET LOCATIONS

The Model/Serial Number label and Tech Sheet locations are shown below.

**Model & Serial  
Number Location**



**Tech Sheet Location  
(On Top Rear Cover)**



# SPECIFICATIONS

Model Number	RF196LXK	RF199LXK	RF314PXK	RF341BXX
Color	Q / T / B / P	Q / T / B / P	W / V / Q	W
<b>GENERAL INFORMATION</b>				
Cleaning System	Self Clean	Self Clean	Std clean	Self Clean
Burner Type	Ceran-Std	Ceran-Dlx. FW	Ceran-Std	Ceran-Std
Burner Sizes	2-6.5",2-7.5"	6"6"7" 9"	2-6.5",2-7.5"	2-6.5",2-7.5"
Drip Pans or Glass Pattern	1 FW Pattern	2 FW Pattern	1 FW Pattern	1 FW Pattern
Oven Door Type	Wht/Bisc/Blk Glass	Wht/Bisc/Blk Glass	Black Glass	Black Glass
Oven Window & Size	XL window	XL window	Yes-Std	No
Oven Controls	EZ151	EZ600	EZ150	Knob 150
Special Features	Clock/timer	AccuBake2	Clock/timer	No Clock Opening
		Dual Display		
		Choice Bake		
<b>DIMENSIONS</b>				
Height - Overall	46.8"	46.8"	46.8"	46.8"
Height to Maintop	36"	36"	36"	36"
Depth	25"	25"	25"	25"
Width	29.875"	29.875"	29.875"	29.875"
Depth with Handle	27.13"	27.13"	27.13"	27.13"
Approx. Shipping Weight	151	151	162	162
<b>BACKGUARD FEATURES</b>				
Timer	in control	in control	No	No
Oven Light Switch	Yes-Rocker	Yes-Touch	No	No
Accusimmer Switch	No	Yes-Selector	No	No
Warming Zone Switch	No	No	No	No
Oven Heating Indicator Light	in Oven Control	in Oven Control	in Oven Control	in Oven Control
Surface Unit Indicator Light	Mini Red (2)	Mini Red (2)	Mini Red (2)	Mini Red (2)
Surface Unit Controls	Inf Detent Hi/Off	Inf Detent Hi/Off	Inf Detent Hi/Off	Inf Detent Hi/Off
<b>COOKTOP FEATURES</b>				
Cooktop	High UpSwp-Porc	High UpSwp-Porc	High UpSwp-Porc	High UpSwp-Porc
Burner Type	Ceran-Std	Ceran-Dlx. FW	Ceran-Std	Ceran-Std
Burner Configuration	2-6.5",2-7.5"	6"6"7" 9"	2-6.5",2-7.5"	2-6.5",2-7.5"
R. Front (240V)	6.5"R-1500W	6"R-1200W	6.5"R-1500W	6.5"R-1500W
L. Front (240V)	7.5"R-2000W	9"R-2500W	7.5"R-2000W	7.5"R-2000W
R. Rear (240V)	7.5"R-2000W	7"R-1800W	7.5"R-2000W	7.5"R-2000W
L. Rear (240V)	6.5"R-1500W	6"R-1200W	6.5"R-1500W	6.5"R-1500W
Middle Rear (120V)	n/a	5th ele - Warm Zone	n/a	n/a
Simmer Burner	n/a	n/a	n/a	n/a
Hot Surface Indicator	1 Neon	4 Neon	1 Neon	1 Neon
Burner Box	No	No	No	No



Model Number	RF196LXK	RF199LXK	RF314PXK	RF341BXK
Color	Q / T / B / P	Q / T / B / P	W / V / Q	W
<b>MAIN CHASSIS FEATURES</b>				
Front Frame	Porcelain	Porcelain	Porcelain	Porcelain
Leveling Legs - Plastic	Four	Four	Four	Four
<b>OVEN FEATURES</b>				
Oven Type	#REF!	#REF!	#REF!	#REF!
Oven Capacity	4.65 cubic ft	4.65 cubic ft	4.65 cubic ft	4.65 cubic ft
Oven Width	24.25"	24.25"	24.25"	24.25"
Oven Height	17.5"	17.5"	17.5"	17.5"
Oven Depth	19.0"	19.0"	19.0"	19.0"
Broil Element	3400w	3400w	3400w	3400w
Bake Element	2400w	2400w	2400w	2400w
Top Heat	Percentage 240V	Percentage 240V	Percentage 240V	Percentage 240V
Oven Light	Yes	Yes	Yes	No
Auto Oven Light	Yes	Yes	No	No
Manual Oven Light	#REF!	#REF!	yes-rocker sw	#REF!
<b>OVEN DOOR FEATURES</b>				
Oven Window & Size	#REF!	#REF!	Yes-std	#REF!
Door Liner Finish	Porcelain	Porcelain	Porcelain	Porcelain
Door Handle	Roper Towel Bar	Roper Towel Bar	Curved Plastic	Curved Plastic
<b>LOWER PANEL/DRAWER</b>				
Width	22.375"	22.375"	22.375"	22.375"
Height	6.125"	6.125"	6.125"	6.125"
Depth	20.0"	20.0"	20.0"	N/A
Drawer Liner	Yes	Yes	No	No
Glides	Rollers	Rollers	Nylon	N/A
Warming Drawer	No	No	No	No
<b>TOTAL CONNECTED LOAD</b>				
240 Volts	10480W	10480W	10180W	10180W
208 Volts	7880W	7880W	7655W	7655W
<b>LITERATURE</b>				
Use & Care Guide	Yes	Yes	Yes	Yes
Tech Sheets/Wiring Diagrams	Yes	Yes	Yes	Yes
Installation Instructions	Yes	Yes	Yes	Yes
Service Manual	8178042	8178042	8178042	8178042
<b>OTHER SPECIFICATIONS</b>				
U.L. Approval	Yes	Yes	Yes	Yes
Anti-Tip Device Approved	Floor Brkt/Wall Brkt.	Floor Brkt/Wall Brkt.	Floor Brkt/Wall Brkt.	Floor Brkt/Wall Brkt.
Anti-Tip Device w/ Unit	Floor Bracket	Floor Bracket	Floor Bracket	Floor Bracket

Model Number	RF364PXX	RF364LXX	RF368LXX
Color	W / V / Q / T	Q / T	Q / T / P / W
<b>GENERAL INFORMATION</b>			
Cleaning System	Self Clean	Self Clean	Self Clean
Burner Type	Ceran-Std	Ceran-Std	Ceran-Dlx. FW
Burner Sizes	2-6.5",2-7.5"	2-6.5",2-7.5"	6"6"7" 9"
Drip Pans or Glass Pattern	1 FW Pattern	1 FW Pattern	2 FW Pattern
Oven Door Type	Black Glass	White/Bisc Glass	Wht/Bisc/Alm Glass
Oven Window & Size	Yes-Std	XL window	XL window
Oven Controls	EZ150	EZ151	EZ151
Special Features	Clock/timer	Clock/timer	Clock/timer
<b>DIMENSIONS</b>			
Height - Overall	46.8"	46.8"	46.8"
Height to Maintop	36"	36"	36"
Depth	25"	25"	25"
Width	29.875"	29.875"	29.875"
Depth with Handle	27.13"	27.13"	27.13"
Approx. Shipping Weight	162	162	162
<b>BACKGUARD FEATURES</b>			
Timer	No	Yes	in control
Oven Light Switch	No	No	Yes-Rocker
Accusimmer Switch	No	No	No
Warming Zone Switch	No	No	No
Oven Heating Indicator Light	in Oven Control	in Oven Control	in Oven Control
Surface Unit Indicator Light	Mini Red (2)	Mini Red (2)	Mini Red (2)
Surface Unit Controls	Inf Detent Hi/Off	Inf Detent Hi/Off	Inf Detent Hi/Off
<b>COOKTOP FEATURES</b>			
Cooktop	High UpSwp-Porc	High UpSwp-Porc	High UpSwp-Porc
Burner Type	Ceran-Std	Ceran-Std	Ceran-Dlx. FW
Burner Configuration	2-6.5",2-7.5"	2-6.5",2-7.5"	6"6"7" 9"
R. Front (240V)	6.5"R-1500W	6.5"R-1500W	6"R-1200W
L. Front (240V)	7.5"R-2000W	7.5"R-2000W	9"R-2500W
R. Rear (240V)	7.5"R-2000W	7.5"R-2000W	7"R-1800W
L. Rear (240V)	6.5"R-1500W	6.5"R-1500W	6"R-1200W
Middle Rear (120V)	n/a	n/a	n/a
Simmer Burner	n/a	n/a	n/a
Hot Surface Indicator	1 Neon	1 Neon	4 Neon
Burner Box	No	No	No

Model Number	RF364PXX	RF364LXK	RF368LXK
Color	W / V / Q / T	Q / T	Q / T / P / W
<b>MAIN CHASSIS FEATURES</b>			
Front Frame	Porcelain	Porcelain	Porcelain
Leveling Legs - Plastic	Four	Four	Four
<b>OVEN FEATURES</b>			
Oven Type	#REF!	#REF!	#REF!
Oven Capacity	4.65 cubic ft	4.65 cubic ft	4.65 cubic ft
Oven Width	24.25"	24.25"	24.25"
Oven Height	17.5"	17.5"	17.5"
Oven Depth	19.0"	19.0"	19.0"
Broil Element	3400w	3400w	3400w
Bake Element	2400w	2400w	2400w
Top Heat	Percentage 240V	Percentage 240V	Percentage 240V
Oven Light	Yes	Yes	Yes
Auto Oven Light	No	No	Yes
Manual Oven Light	yes-rocker sw	yes-rocker sw	#REF!
<b>OVEN DOOR FEATURES</b>			
Oven Window & Size	Yes-std	#REF!	#REF!
Door Liner Finish	Porcelain	Porcelain	Porcelain
Door Handle	Curved Plastic	Curved Plastic	Curved Plastic
<b>LOWER PANEL/DRAWER</b>			
Width	22.375"	22.375"	22.375"
Height	6.125"	6.125"	6.125"
Depth	20.0"	20.0"	20.0"
Drawer Liner	No	No	Yes
Glides	Nylon	Rollers	Nylon
Warming Drawer	No	No	No
<b>TOTAL CONNECTED LOAD</b>			
240 Volts	10180W	10180W	10180W
208 Volts	7655W	7655W	7655W
<b>LITERATURE</b>			
Use & Care Guide	Yes	Yes	Yes
Tech Sheets/Wiring Diagrams	Yes	Yes	Yes
Installation Instructions	Yes	Yes	Yes
Service Manual	8178042	8178042	8178042
<b>OTHER SPECIFICATIONS</b>			
U.L. Approval	Yes	Yes	Yes
Anti-Tip Device Approved	Floor Brkt/Wall Brkt.	Floor Brkt/Wall Brkt.	Floor Brkt/Wall Brkt.
Anti-Tip Device w/ Unit	Floor Bracket	Floor Bracket	Floor Bracket

Model Number	RF378LXK	RF378PXK	RF388LXK	RF390LXK
Color	W / V	Q / T / B	Q / T / B / P	Q / T / P
<b>GENERAL INFORMATION</b>				
Cleaning System	Self Clean	Self Clean	Self Clean	Self Clean
Burner Type	Ceran-Dlx. FW	Ceran-Dlx. FW	Ceran-Dlx. FW	Ceran-Dlx. FW
Burner Sizes	6"6"7" 9"	6"6"7" 9"	6"6"7" 9"	6"6"7" 9"
Oven Window & Size	XL window	XL window	XL window	XL window
Oven Controls	EZ200	EZ200	EZ600	EZ600
Special Features	Accubake I	Accubake I	Accubake 2	Accubake 2
			Accusimmer	Accusimmer
	Dual Display	Dual Display	Dual Display	Dual Display
			Choice Bake	Choice Bake
<b>DIMENSIONS</b>				
Height - Overall	46.8"	46.8"	46.8"	46.8"
Height to Maintop	36"	36"	36"	36"
Depth	25"	25"	25"	25"
Width	29.875"	29.875"	29.875"	29.875"
Depth with Handle	27.13"	27.13"	27.13"	27.13"
Approx. Shipping Weight	162	162	163	163
<b>BACKGUARD FEATURES</b>				
Timer	in control	in control	in control	in control
Oven Light Switch	Yes-Touch	Yes-Touch	Yes-Touch	Yes-Touch
Accusimmer Switch	No	No	Yes-Selector	Yes-Selector
Warming Zone Switch	No	No	No	No
Oven Heating Indicator Light	in Oven Control	in Oven Control	in Oven Control	in Oven Control
Surface Unit Indicator Light	Mini Red (2)	Mini Red (2)	Mini Red (3)	Mini Red (3)
Surface Unit Controls	Inf Detent Hi/Off	Inf Detent Hi/Off	Inf Detent Hi/Off	Inf Detent Hi/Off
<b>COOKTOP FEATURES</b>				
Cooktop	High UpSwp-Porc	High UpSwp-Porc	High UpSwp-Porc	High UpSwp-Porc
Burner Type	Ceran-Dlx. FW	Ceran-Dlx. FW	Ceran-Dlx. FW	Ceran-Dlx. FW
Burner Configuration	6"6"7" 9"	6"6"7" 9"	6"6"7" 9"	6"6"7" 9"
R. Front (240V)	6"R-1200W	6"R-1200W	6"R-1200W	6"R-1200W
L. Front (240V)	9"R-2500W	9"R-2500W	9"R-2500W	9"R-2500W
R. Rear (240V)	7"R-1800W	7"R-1800W	7"R-1800W	7"R-1800W
L. Rear (240V)	6"R-1200W	6"R-1200W	6"R-1200W	6"R-1200W
Middle Rear (120V)	n/a	n/a	n/a	n/a
Simmer Burner	n/a	n/a	L. Front	L. Front
<b>MAIN CHASSIS FEATURES</b>				
Cabinet	Painted- Text Stl	Painted- Text Stl	Painted- Text Stl	Painted- Text Stl
Front Frame	Porcelain	Porcelain	Porcelain	Porcelain
Leveling Legs - Plastic	Four	Four	Four	Four

Model Number	RF378LXK	RF378PXK	RF388LXK	RF390LXK
Color	W / V	Q / T / B	Q / T / B / P	Q / T / P
<b>OVEN FEATURES</b>				
Oven Type	#REF!	#REF!	#REF!	#REF!
Oven Capacity	4.65 cubic ft	4.65 cubic ft	4.65 cubic ft	4.65 cubic ft
Oven Width	24.25"	24.25"	24.25"	24.25"
Oven Height	17.5"	17.5"	17.5"	17.5"
Oven Depth	19.0"	19.0"	19.0"	19.0"
Broil Element	3400w	3400w	3400w	3400w
Bake Element	2400w	2400w	2400w	2400w
Top Heat	Percentage 240V	Percentage 240V	Percentage 240V	Percentage 240V
Oven Light	Yes	Yes	Yes	Yes
Auto Oven Light	Yes	Yes	Yes	Yes
Manual Oven Light	#REF!	#REF!	#REF!	#REF!
<b>OVEN DOOR FEATURES</b>				
Oven Window & Size	#REF!	#REF!	#REF!	#REF!
Door Latch	Yes-Auto	Yes-Auto	Yes-Auto	Yes-Auto
Removable Door & Hinges	Yes	Yes	Yes	Yes
Door Liner Finish	Porcelain	Porcelain	Porcelain	Porcelain
Oven Door Vent Color	Blk	White/Bisc/Black	Wht/Bisc/Blk	Wht/Bisc
Door Handle	Curved Plastic	Curved Plastic	Curved Plastic	Curved Plastic
Door Handle Color	Blk	White/Bisc/Black	Wht/Bisc/Blk	Wht/Bisc
Special Features	n/a	n/a	n/a	n/a
<b>LOWER PANEL/DRAWER</b>				
Width	22.375"	22.375"	22.375"	22.375"
Height	6.125"	6.125"	6.125"	6.125"
Depth	20.0"	20.0"	20.0"	20.0"
Drawer Liner	Yes	Yes	Yes	Yes
Glides	Rollers	Rollers	Rollers	Rollers
Warming Drawer	No	No	No	No
<b>TOTAL CONNECTED LOAD</b>				
240 Volts	10180W	10180W	12580W	12580W
208 Volts	7655W	7655W	9455W	9455W
<b>LITERATURE</b>				
Use & Care Guide	Yes	Yes	Yes	Yes
Tech Sheets/Wiring Diagrams	Yes	Yes	Yes	Yes
Installation Instructions	Yes	Yes	Yes	Yes
Service Manual	8178042	8178042	8178042	8178042
<b>OTHER SPECIFICATIONS</b>				
U.L. Approval	Yes	Yes	Yes	Yes
Anti-Tip Device Approved	Floor Brkt/Wall Brkt.	Floor Brkt/Wall Brkt.	Floor Brkt/Wall Brkt.	Floor Brkt/Wall Brkt.
Anti-Tip Device w/ Unit	Floor Bracket	Floor Bracket	Floor Bracket	Floor Bracket

Model Number	GR460LXK	GR470LXK	GR475LXK	GR450LXH
Color	T / B / P	Q / T / B	S	Q / B
<b>GENERAL INFORMATION</b>				
Cleaning System	Self Clean	Self Clean	Self Clean	Self Clean
Burner Type	Ceran-Dlx. FW	Ceran-Dlx. FW	Ceran-Dlx. FW	Ceran-Dlx. FW
Burner Sizes	6"6"7" 9"	6"6"7"9"	6"6"7"9"/6"	6"6"7"9"/6"
Oven Window & Size	XL window	XL window	XL window	XL window
Oven Controls	EZ605	EZ625	EZ625	EZ400
Special Features	Accubake 2	Accubake 2	Accubake 2	Accubake 1
	Accusimmer	Accusimmer	Accusimmer	Accusimmer
	Sentence Logic	Sentence Logic	Sentence Logic	
	Dual Display	Dual Display	Dual Display	Dual Display
	Choice Bake	Choice Bake	Choice Bake	
<b>DIMENSIONS</b>				
Height - Overall	46.8"	46.8"	46.8"	46.8"
Height to Maintop	36"	36"	36"	36"
Depth	25"	25"	25"	25"
Width	29.875"	29.875"	29.875"	29.875"
Depth with Handle	27.13"	27.13"	27.13"	27.13"
Approx. Shipping Weight	167	167	167	167
<b>BACKGUARD FEATURES</b>				
Timer	in control	in control	in control	in control
Oven Light Switch	Yes-Touch	Yes-Touch	Yes-Touch	Yes-Touch
Accusimmer Switch	Yes-Selector	Yes-Selector	Yes-Selector	Yes-Selector
Warming Zone Switch	No	Yes-small infinite	Yes-small infinite	Yes-small infinite
Oven Heating Indicator Light	in Oven Control	in Oven Control	in Oven Control	in Oven Control
Surface Unit Indicator Light	Mini Red (3)	Mini Red (3)	Mini Red (3)	Mini Red (3)
Surface Unit Controls	Inf Detent Hi/Off	Inf Detent Hi/Off	Inf Detent Hi/Off	Inf Detent Hi/Off
<b>COOKTOP FEATURES</b>				
Cooktop	High UpSwp-Porc	High UpSwp-Porc	High UpSwp-Porc	High UpSwp-Porc
Burner Type	Ceran-Dlx. FW	Ceran-Dlx. FW	Ceran-Dlx. FW	Ceran-Dlx. FW
Burner Configuration	6"6"7" 9"	6"6"7"9"	6"6"7"9"/6"	6"6"7"9"/6"
R. Front (240V)	6"R-1200W	6"R-1200W	6"R-1200W	6"R-1200W
L. Front (240V)	9"R-2500W	9"/6"R-2400W/1000W	9"/6"R-2400W/1000W	9"/6"R-2400W/1000W
R. Rear (240V)	7"R-1800W	7"R-1800W	7"R-1800W	7"R-1800W
L. Rear (240V)	6"R-1200W	6"R-1200W	6"R-1200W	6"R-1200W
Middle Rear (120V)	5th ele - 7"R-100W	5th ele - 7"R-100W	5th ele - 7"R-100W	5th ele - 7"R-100W
Simmer Burner	L. Front	L. Front	L. Front	L. Front
<b>MAIN CHASSIS FEATURES</b>				
Cabinet	Painted- Text Stl	Painted- Text Stl	Painted- Text Stl	Painted- Text Stl
Front Frame	Porcelain	Porcelain	Porcelain	Porcelain
Leveling Legs - Plastic	Four	Four	Four	Four

Model Number	<b>GR460LXK</b>	<b>GR470LXK</b>	<b>GR475LXK</b>	<b>GR450LXH</b>
Color	<b>T / B / P</b>	<b>Q / T / B</b>	<b>S</b>	<b>Q / B</b>
<b>OVEN FEATURES</b>				
Oven Type	#REF!	#REF!	#REF!	#REF!
Oven Capacity	4.65 cubic ft	4.65 cubic ft	4.65 cubic ft	4.65 cubic ft
Oven Width	24.25"	24.25"	24.25"	24.25"
Oven Height	17.5"	17.5"	17.5"	17.5"
Oven Depth	19.0"	19.0"	19.0"	19.0"
Broil Element	3400w	3400w	3400w	3400w
Bake Element	2400w	2400w	2400w	2400w
Top Heat	Percentage 240V	Percentage 240V	Percentage 240V	Percentage 240V
Oven Light	Yes	Yes	Yes	Yes
Auto Oven Light	Yes	Yes	Yes	Yes
Manual Oven Light	#REF!	#REF!	#REF!	#REF!
<b>OVEN DOOR FEATURES</b>				
Oven Window & Size	#REF!	#REF!	#REF!	#REF!
Door Latch	Yes-Auto	Yes-Auto	Yes-Auto	Yes-Auto
Removable Door & Hinges	Yes	Yes	Yes	Yes
Door Liner Finish	Porcelain	Porcelain	Porcelain	Porcelain
Oven Door Vent Color	Wht/Bisc/Blk Glass	Wht/Bisc/Blk	Black	Wht/Blk
Door Handle	Curved Plastic	Curved Plastic	Curved Plastic	Curved Plastic
Door Handle Color	Wht/Bisc/Blk Glass	Wht/Bisc/Blk	Black	Black
Special Features	Air Cushion Door	Air Cushion Door	Air Cushion Door	Air Cushion Door
<b>LOWER PANEL/DRAWER</b>				
Width	22.375"	22.375"	22.375"	22.375"
Height	6.125"	6.125"	6.125"	6.125"
Depth	20.0"	20.0"	20.0"	20.0"
Drawer Liner	Yes	Yes	Yes	No
Glides	Rollers	Rollers	Warming/AccuRide	Nylon
Warming Drawer	No	Yes	Yes	No
<b>TOTAL CONNECTED LOAD</b>				
240 Volts	12580W	12780W	12780W	12780W
208 Volts	9455W	9655W	9655W	9655W
<b>LITERATURE</b>				
Use & Care Guide	Yes	Yes	Yes	Yes
Tech Sheets/Wiring Diagrams	Yes	Yes	Yes	Yes
Installation Instructions	Yes	Yes	Yes	Yes
Service Manual	8178042	8178042	8178042	8178042
<b>OTHER SPECIFICATIONS</b>				
U.L. Approval	Yes	Yes	Yes	Yes
Anti-Tip Device Approved	Floor Brkt/Wall Brkt.	Floor Brkt/Wall Brkt.	Floor Brkt/Wall Brkt.	Floor Brkt/Wall Brkt.
Anti-Tip Device w/ Unit	Floor Bracket	Floor Bracket	Floor Bracket	Floor Bracket

# WHIRLPOOL ELECTRIC RANGE WARRANTY

LENGTH OF WARRANTY:	WHIRLPOOL WILL PAY FOR:	WHIRLPOOL WILL NOT PAY FOR:
<p><b>FULL ONE-YEAR WARRANTY FROM DATE OF PURCHASE.</b></p>	<p>FSP® replacement parts and repair labor costs to correct defects in materials or workmanship. Service must be provided by a Whirlpool-designated service company.</p>	<p>A. Service calls to:</p> <ol style="list-style-type: none"> <li>1. Correct the installation of the range.</li> <li>2. Instruct you how to use the range.</li> <li>3. Replace house fuses or correct house wiring.</li> <li>4. Replace owner-accessible light bulbs.</li> </ol> <p>B. Repairs when the range is used in other than normal, single-family household use.</p> <p>C. Pickup and delivery. The range is designed to be repaired in the home.</p> <p>D. Damage to the range caused by accident, alteration, misuse, abuse, fire, flood, acts of God, or use of products not approved by Whirlpool.</p> <p>E. Repairs to CLEANTOP® ceramic glass cooktop if it has not been cared for as recommended in the Use And Care guide.</p> <p>F. Repairs to parts or systems resulting from unauthorized modifications made to the appliance.</p> <p>G. Replacement parts or repair labor costs for units operated outside the United States.</p>
<p><b>FULL FIVE-YEAR WARRANTY FROM DATE OF PURCHASE.</b></p>	<p>For ranges with a ceramic glass cooktop only: FSP® replacement parts and repair labor for CLEAN-TOP® ceramic glass cooktop.</p> <p>Whirlpool warrants that:</p> <ul style="list-style-type: none"> <li>- The ceramic glass cooktop will not discolor.</li> <li>- The ceramic glass cooktop pattern will not wear off.</li> <li>- The rubber seal between the ceramic glass cooktop and porcelain edge will not crack.</li> <li>- The ceramic glass cooktop will not crack due to thermal shock.</li> <li>- The surface unit elements will not burn out.</li> </ul> <p>Service must be provided by a Whirlpool-designated service company.</p>	

**WHIRLPOOL CORPORATION SHALL NOT BE LIABLE FOR INCIDENTAL OR CONSEQUENTIAL DAMAGES.**

Some states do not allow the exclusion or limitation of incidental or consequential damages, so this exclusion or limitation may not apply to you. This warranty gives specific legal rights and you may also have other rights which vary from state to state.

**Outside the United States, a different warranty may apply. For details, please contact your authorized Whirlpool dealer.**

If you need service, first see the “Troubleshooting” section of the Use & Care Guide. After checking “Troubleshooting,” additional help can be found by checking the “Requesting Assistance Or Service” section, or by calling the Whirlpool Consumer Assistance Center telephone number, **1-800-253-1301**, from anywhere in the U.S.A.



# THEORY OF OPERATION

## ACCUBAKE VS. ACCUBAKE DUO COOKING SYSTEMS

Both AccuBake and AccuBake Duo cooking systems will be used on K-line freestanding gas and electric self-cleaning ranges. The changes between the AccuBake and AccuBake Duo systems, (refer to the illustration below), include the addition of a second temperature sensor within the oven cavity, and software changes to the electronic oven control.

The AccuBake system has been available on ranges since 1996. It used a temperature sensor and an electronic oven control to monitor and maintain even heat throughout the cooking cycle. The system created a cooking environment that could evenly cook a variety of foods with very consistent results. The AccuBake system used one temperature sensor to monitor temperatures throughout the oven cavity, and cycle both the bake and broil elements on at predetermined times during the cycle. The bake and broil elements work simultaneously to maintain proper heat.

The AccuBake Duo system, which will be used on Whirlpool “Gold Series” models, uses a second temperature sensor to provide a more uniform temperature distribution throughout the oven cavity. The AccuBake Duo system uses two electronic temperature sensors inside the oven cavity to help control temperatures, but the sensors work independently to provide proper heat at the top and at the bottom of the oven cavity. The top sensor controls temperatures at the top of the oven cavity, and controls the operation of the top (broil) element. The bottom sensor controls the operation of the bottom (bake) element. By using two independent sensors, the temperature within the oven is more evenly distributed.

For servicing the system, it is important to know that neither of the oven elements are on at the same time, except during preheat in the electric oven. During that time, the bake element is on for one hundred percent (100%) of the time, and the broil element is on for thirty-three percent (33%) of the time. During preheat on gas models, the bake burner is on for one hundred percent (100%) of the time.

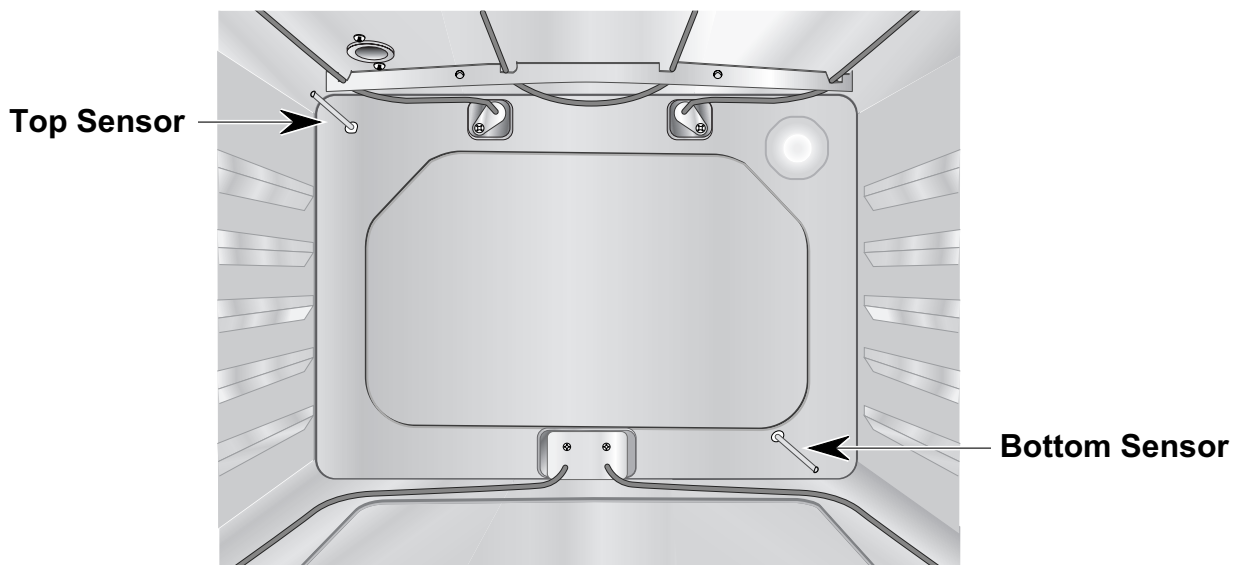

## REGULAR BAKE CYCLE

During Regular Bake, the bake element is the main source of heat in the oven, and will remain on until the lower sensor is satisfied. In the AccuBake system, the bake and broil elements are programmed to operate for a defined percentage of time during each one minute cycle.

In the AccuBake Duo system, the bake element is on for 24 seconds out of every minute, and the broil element will cycle for 10 seconds out of every minute. If the bake element is operating, the broil element will remain off until the bake element cycles off.

The cooking results on an AccuBake Duo gas range will be noticeably different than on any previously manufactured gas range, due to an added top heat feature.

The broil element will not cycle on, even though it may sense cooler temperatures, until the lower element has cycled off.

NOTE: During a normal 350° Bake cycle, the top element may not turn on for 5 minutes, or until the top sensor calls for heat.

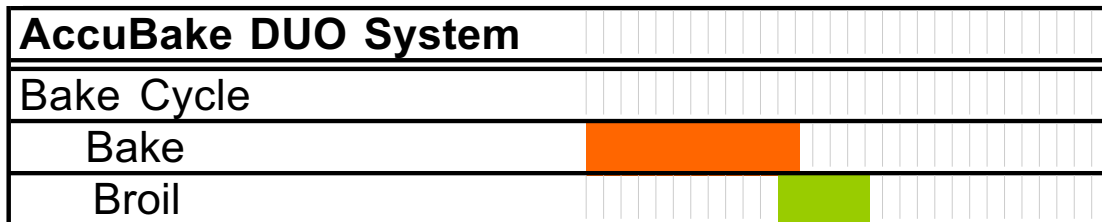

TYPICAL 1 MINUTE CYCLES

## CHOICE BAKE

The Choice Bake cycle turns the top sensor off to eliminate top heat in the oven. The Choice Bake feature is not available during the Broil mode.

## WARM

The Warm feature defaults the oven to a “keep warm” condition after a cooking cycle. The default temperature is 170°, but can be programmed for 100° to 200°. The Warm feature is independent and does not need to be programmed with a cooking cycle. It can be programmed at any time.

# ACCUSIMMER BASIC OPERATION



The AccuSimmer element is located at the left front position of the cooktop. The burner uses a dual element with a 1600 watt inner coil, and an 800 watt outer coil.

The controls (infinite switch and AccuSimmer switch) for the element are both located on the left side of the control panel, as shown above. The infinite switch for the AccuSimmer is different than the other infinite switches, because of

the dual burner that it controls. It can be set for the "DUAL" or "SINGLE" position. The illustrations below show the internal circuitry for the switch.

The two coils can be activated individually or together, depending on the setting of the infinite switch. During AccuSimmer, the coils can also be activated individually or together, but are used across a 120 VAC circuit.

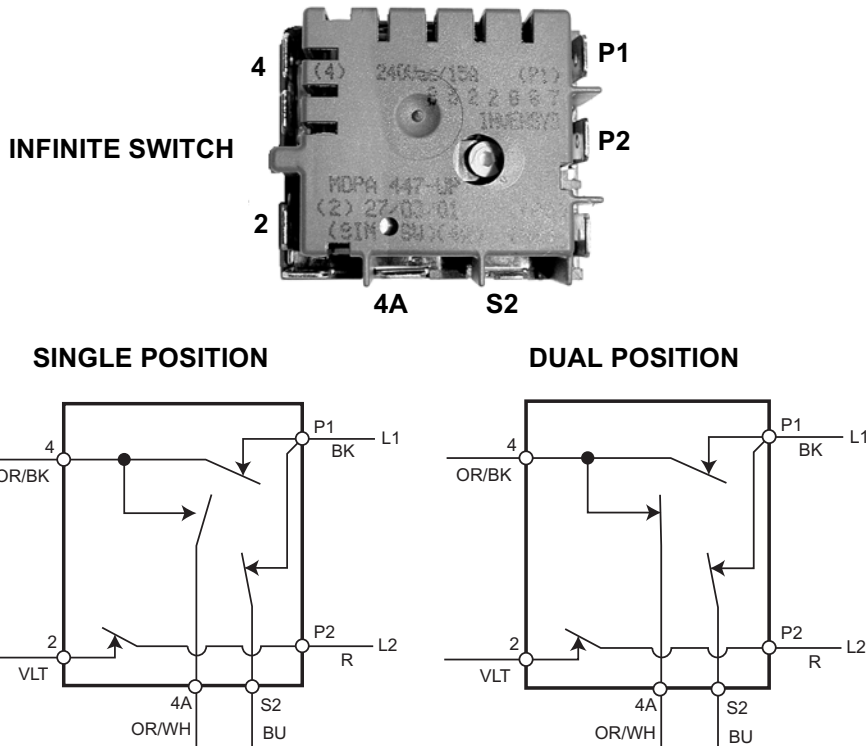

During the AccuSimmer cycle, 120 VAC is activated across the element(s). This reduction of voltage is achieved by use of the AccuSimmer switch. The switch has two positions: Normal and AccuSimmer. There are two

internal contacts inside the switch, as shown below. The Normal position provides a circuit from L1 to L2 to create 240 VAC for the normal burner (both coils of the element). The AccuSimmer position provides a circuit from L1 to neutral for 120 VAC.

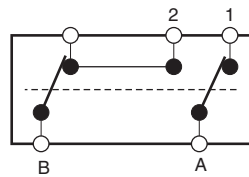
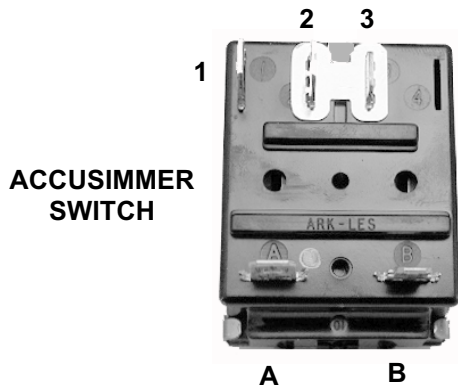
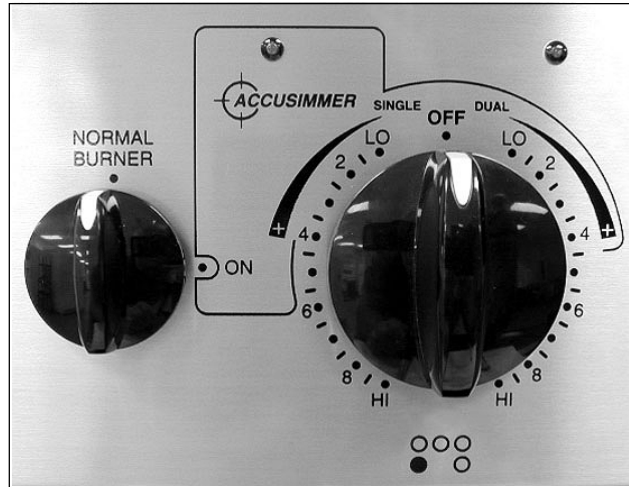

**ACCUSIMMER  
"ON" POSITION**

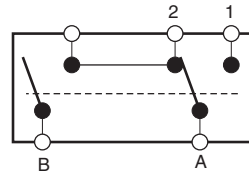

**NORMAL\*  
POSITION**

\* As Shown On Wiring Diagram

## DUAL FULL POWER

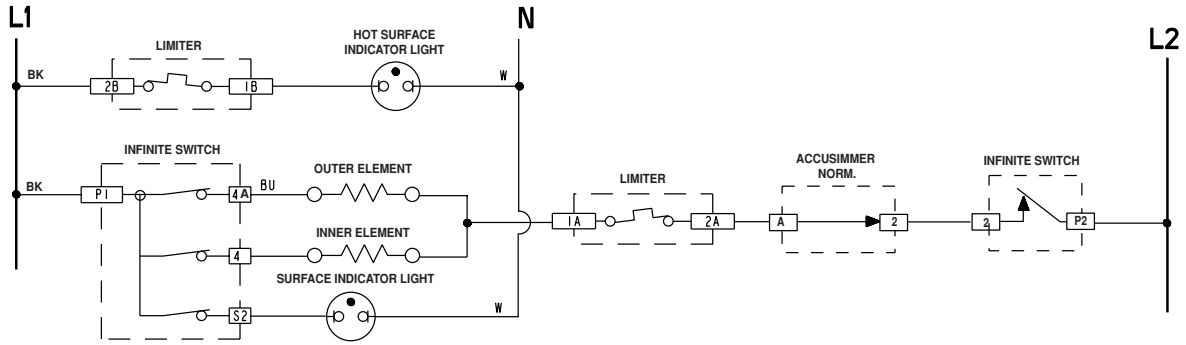

## DUAL ACCUSIMMER

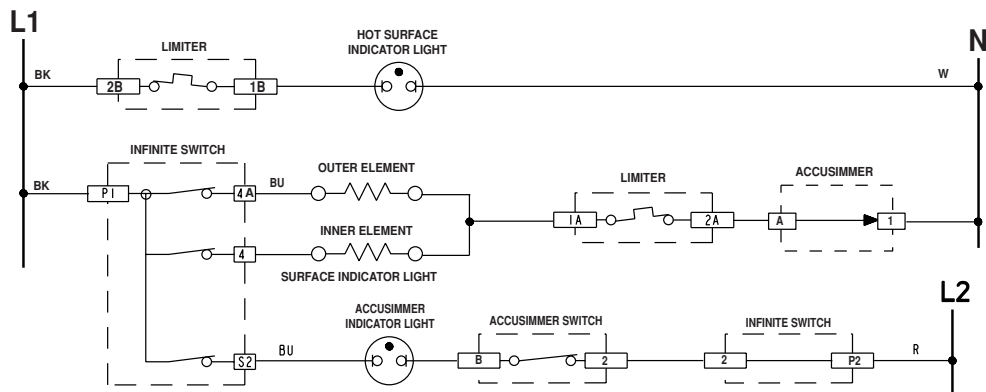

## SINGLE FULL POWER

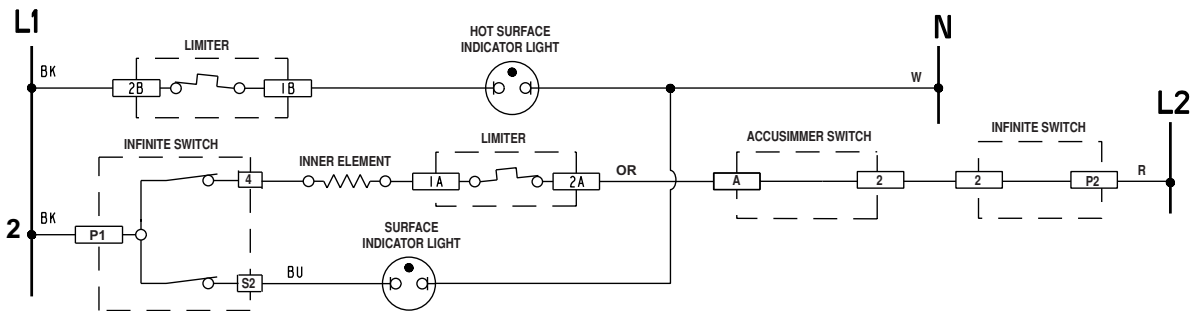

## SINGLE ACCUSIMMER

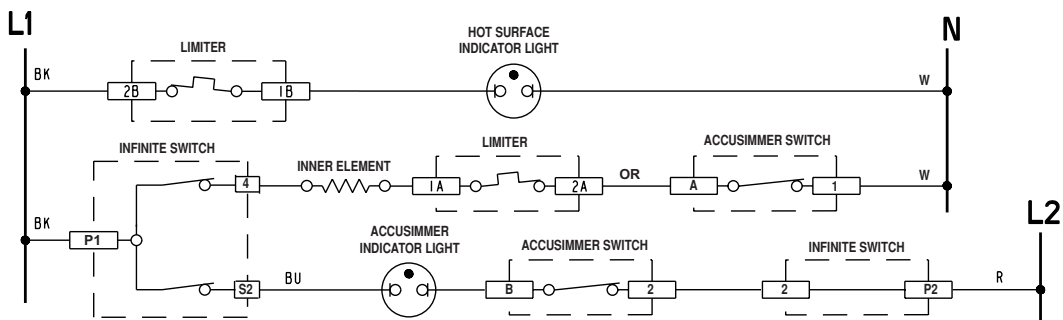

# KEEP WARM ELEMENT

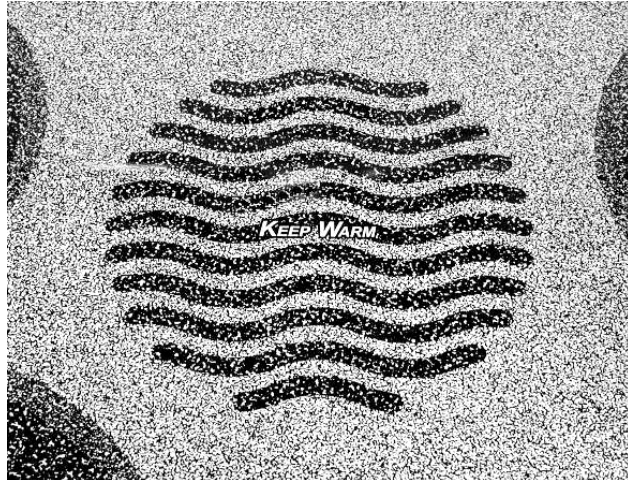

A fifth element is an added feature to the electric range, and is located at the center of the cooktop. This fifth element can be used to keep foods warm when other foods are being

prepared. The fifth element operates at temperatures of between 100 degrees and 200 degrees. This 100 watt element operates across L1 and Neutral (120 VAC) to maintain the lower temperatures.

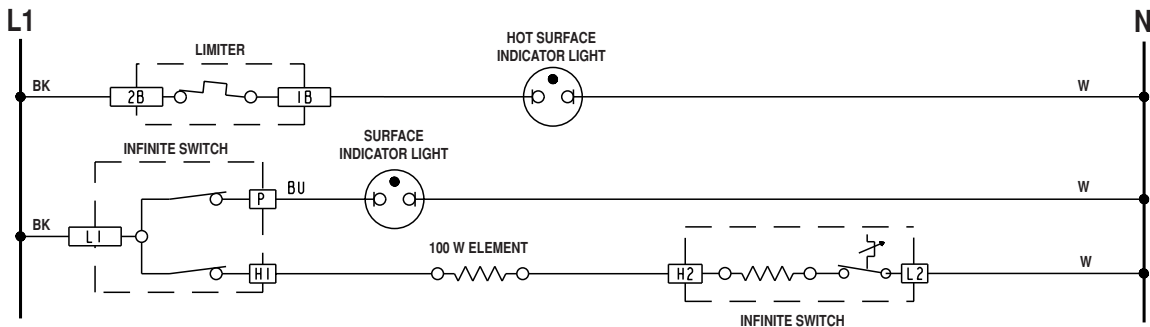
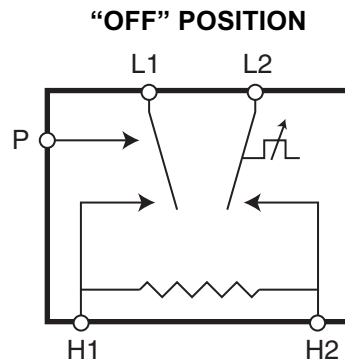
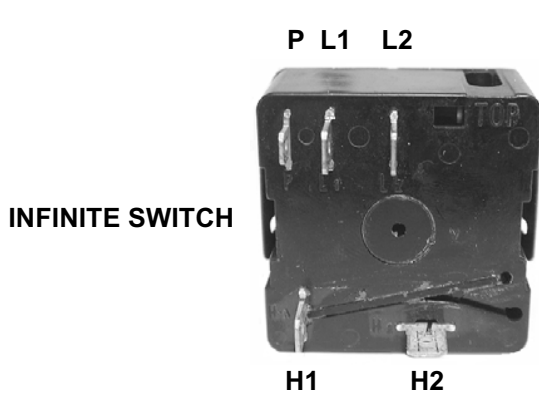

# WARMING DRAWER



TEMPERATURE °F	SETTINGS
108	LOW
140	2
160	3
180	4
195	HI

The warming drawer is accessed through the electronic oven control. It operates an 850 watt heating element across 120 VAC (L1 to Neutral) that maintains a temperature of between 108 and 195 degrees. As you turn the warming drawer on, it will default to the main setting of 108 degrees (LOW). Other warming drawer temperatures may also be programmed, as shown in the chart. The temperature of the drawer is controlled by a sensor that is similar to the main oven sensors. The warming drawer sensor resistance is approximately 100 K $\Omega$  at room temperature.

**NOTE:** To cancel the warming drawer operation, press the DRAWER OFF keypad.

The warming drawer is supplied with an insulated liner that maintains the proper temperature within the drawer. The chart, shown above, indicates the warming drawer temperatures with the liner in place. If the liner is removed, the operating temperatures will increase by 10° to 20°F. Do not use the warming drawer liner inside the oven.

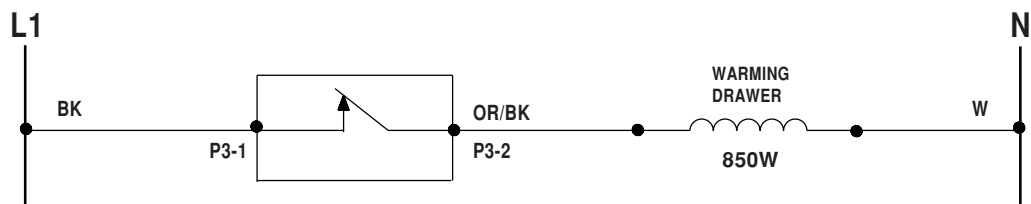

## SOFT CLOSE DOOR

Gold Series ranges will use a “Soft Close” door feature. This feature allows the oven door to be opened to any position, (between 30° and 80°), and will remain in that position until it is pushed closed. When the door is pushed, an oil-filled cylinder will dampen the closing action, and the

door will close softly against the front of the range. The concept is similar to that which is used on screen doors, or on the hatchbacks of cars. The oil-filled cylinder is part of one of the range hinge assemblies, and can be mounted on either side.

Soft Close Door



Hinge Assembly With Oil-Filled Cylinder

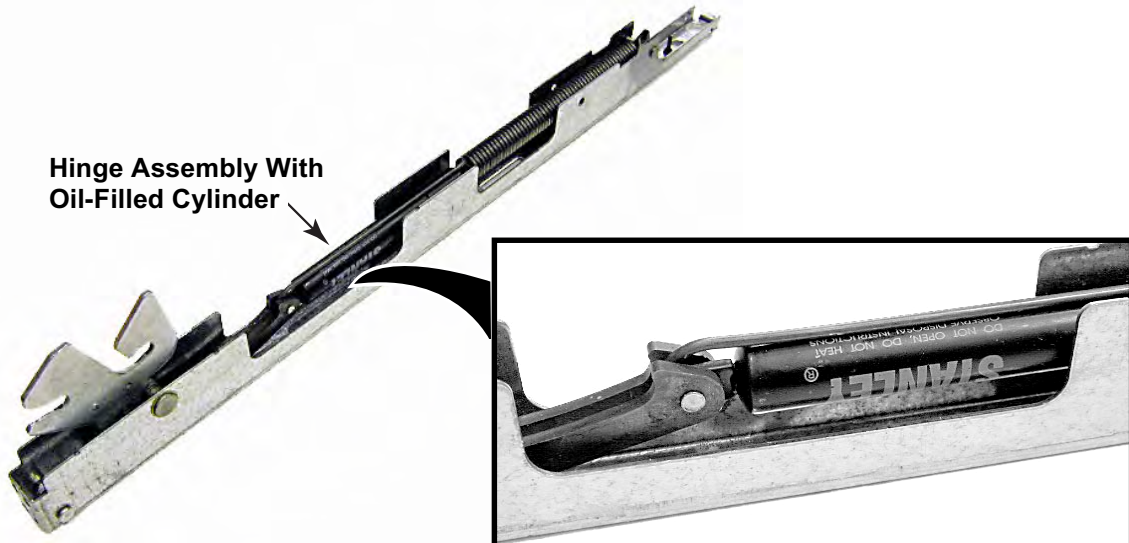



# COMPONENT ACCESS

This section instructs you on how to service each component inside the range. The components and their locations are shown below.

## COMPONENT LOCATIONS

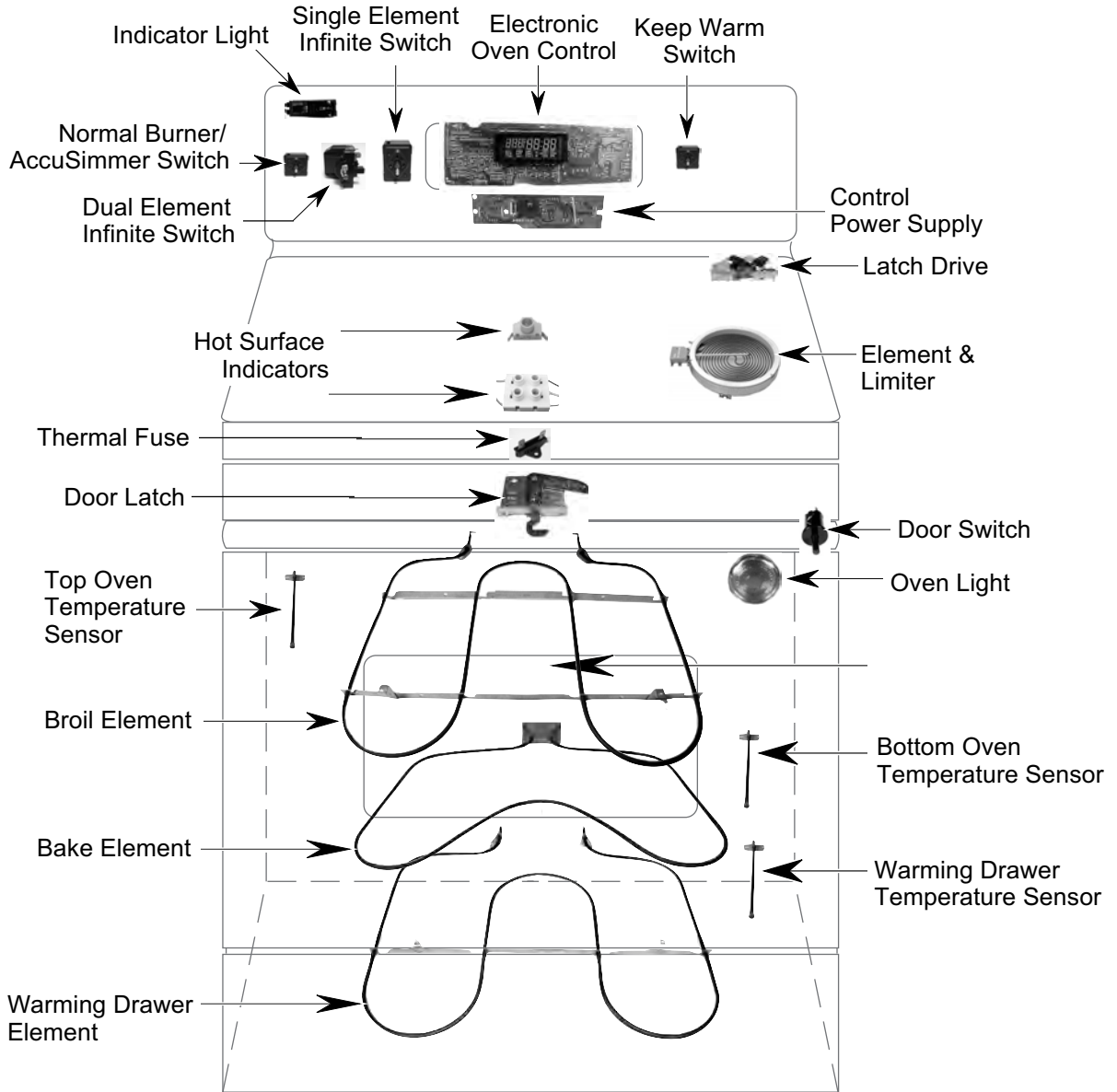

# REMOVING A SINGLE ELEMENT INFINITE SWITCH

## **! WARNING**

### **ELECTRICAL SHOCK HAZARD**

Disconnect power before servicing the range.  
 Replace all panels before operating range.  
 Failure to do so can result in death or electrical shock.

**CAUTION:** When you work on the electric range, be careful when handling the sheet metal parts. Sharp edges may be present, and you can cut yourself if you are not careful.

1. Turn off the electrical supply going to the range.
2. Pull the knob off the single element infinite switch you wish to service and remove the two screws.

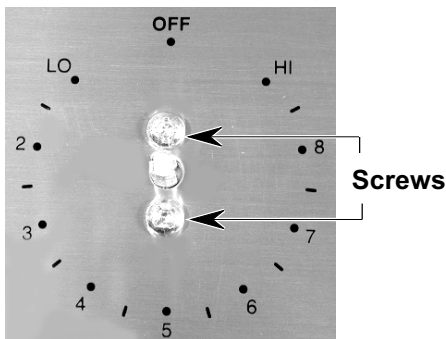

3. Pull the range away from the wall so that you can access the rear panel.
4. Remove the eight screws from the rear panel and remove the panel.

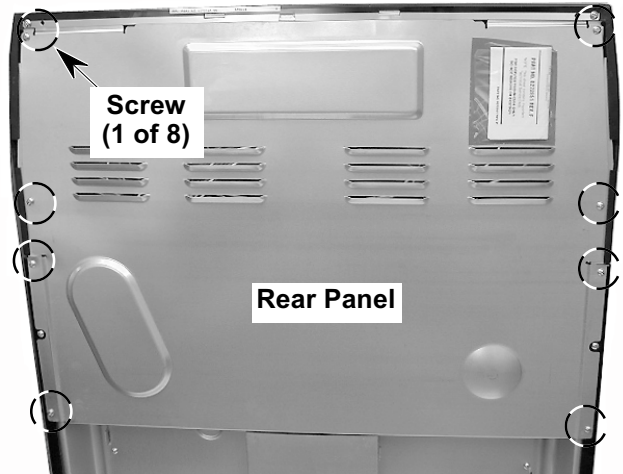

5. Remove the wires from the single element infinite switch terminals and remove the switch.

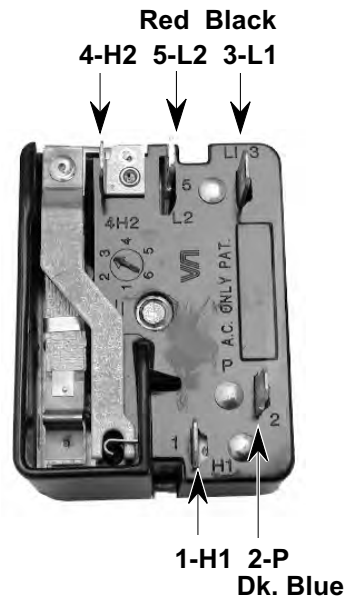
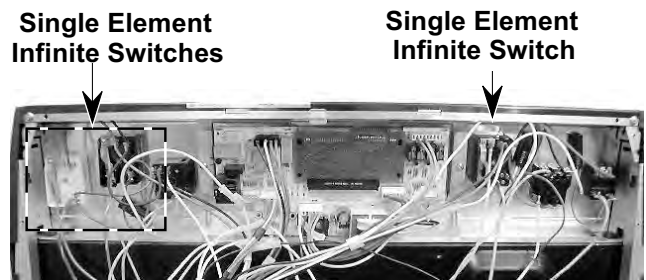

## REMOVING THE NORMAL BURNER/ ACCUSIMMER SWITCH

### **! WARNING**

#### **ELECTRICAL SHOCK HAZARD**

Disconnect power before servicing the range.  
Replace all panels before operating range.  
Failure to do so can result in death or electrical shock.

**CAUTION:** When you work on the electric range, be careful when handling the sheet metal parts. Sharp edges may be present, and you can cut yourself if you are not careful.

1. Turn off the electrical supply going to the range.
2. Pull the knob off the Normal Burner/ AccuSimmer switch and remove the two screws.

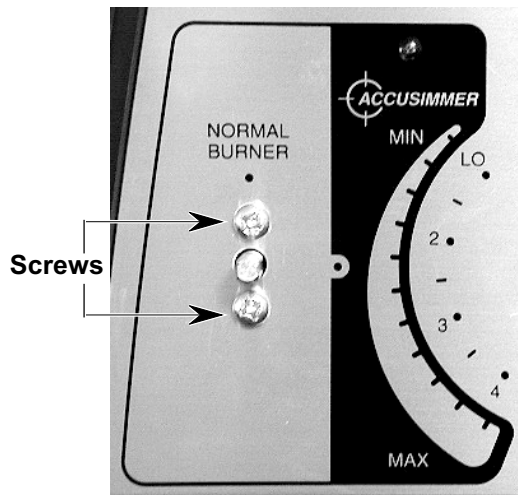

3. Pull the range away from the wall so that you can access the rear panel.
4. Remove the eight screws from the rear panel and remove the panel (see step 4 on page 3-2).
5. Remove the wires from the Normal Burner/ AccuSimmer switch terminals and remove the switch.

**Normal Burner/  
AccuSimmer Switch**



# REMOVING THE DUAL ELEMENT INFINITE SWITCH

## **! WARNING**

### **ELECTRICAL SHOCK HAZARD**

Disconnect power before servicing the range.  
 Replace all panels before operating range.  
 Failure to do so can result in death or electrical shock.

**CAUTION:** When you work on the electric range, be careful when handling the sheet metal parts. Sharp edges may be present, and you can cut yourself if you are not careful.

1. Turn off the electrical supply going to the range.
2. Pull the knob off the dual element infinite switch and remove the two screws.

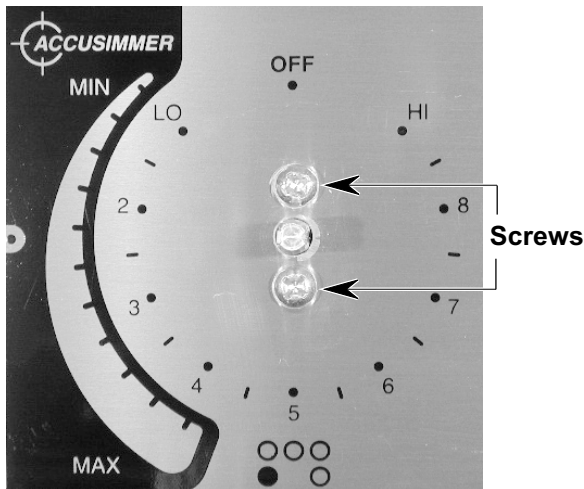

3. Pull the range away from the wall so that you can access the rear panel.
4. Remove the eight screws from the rear panel and remove the panel (see step 4 on page 3-2).
5. Remove the wires from the dual element infinite switch terminals and remove the switch.

**Dual Element Infinite Switch**

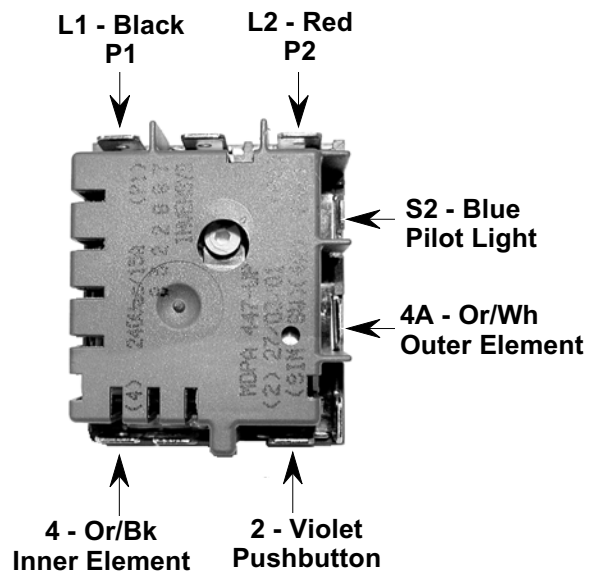
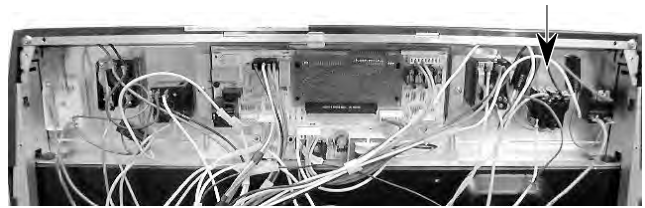

## REMOVING THE KEEP WARM SWITCH

### **! WARNING**

#### **ELECTRICAL SHOCK HAZARD**

Disconnect power before servicing the range.  
Replace all panels before operating range.  
Failure to do so can result in death or electrical shock.

**CAUTION:** When you work on the electric range, be careful when handling the sheet metal parts. Sharp edges may be present, and you can cut yourself if you are not careful.

1. Turn off the electrical supply going to the range.
2. Pull the knob off the Keep Warm switch and remove the two screws.

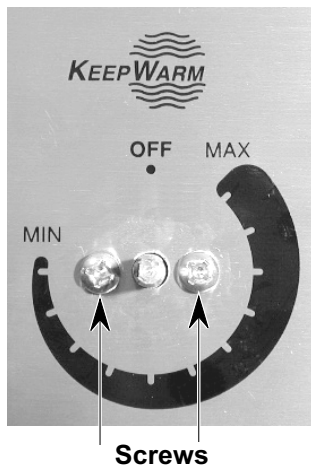

3. Pull the range away from the wall so that you can access the rear panel.
4. Remove the eight screws from the rear panel and remove the panel (see step 4 on page 3-2).
5. Remove the wires from the Keep Warm switch terminals and remove the switch.

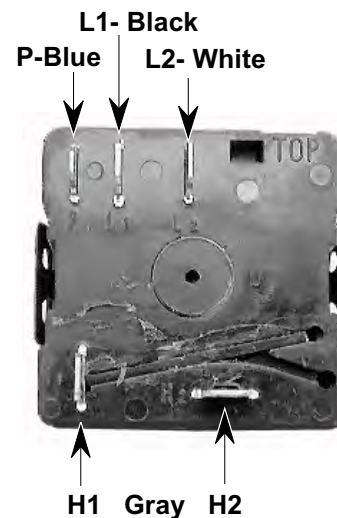
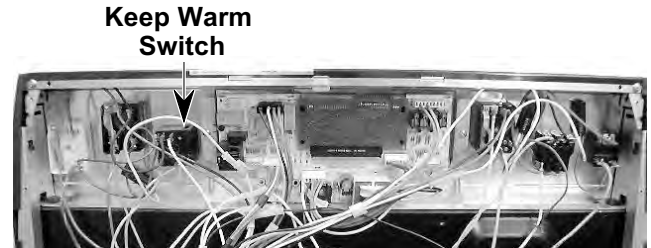

## REMOVING AN INDICATOR LIGHT

### **! WARNING**

#### **ELECTRICAL SHOCK HAZARD**

Disconnect power before servicing the range.  
Replace all panels before operating range.  
Failure to do so can result in death or electrical shock.

**CAUTION:** When you work on the electric range, be careful when handling the sheet metal parts. Sharp edges may be present, and you can cut yourself if you are not careful.

1. Turn off the electrical supply going to the range.
2. Pull the range away from the wall so that you can access the rear panel.
3. Remove the eight screws from the rear panel and remove the panel (see step 4 on page 3-2).

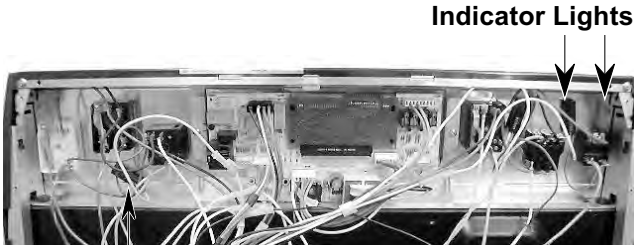

Indicator Light

4. To remove an indicator light, push on the body and slide the clip off the shoulder of the lens.

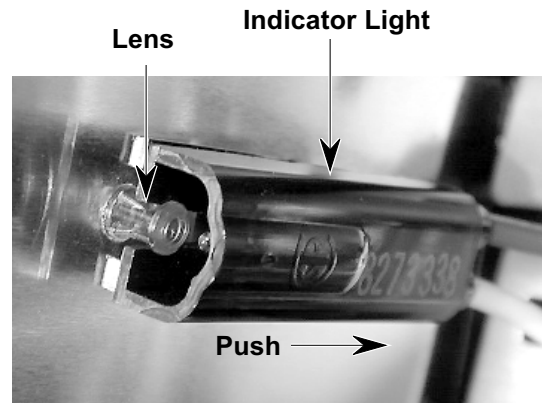

5. Disconnect the two indicator wires from the terminals.

## REMOVING THE CONTROL POWER SUPPLY AND THE ELECTRONIC OVEN CONTROL

### **! WARNING**

#### **ELECTRICAL SHOCK HAZARD**

Disconnect power before servicing the range.  
Replace all panels before operating range.  
Failure to do so can result in death or electrical shock.

**CAUTION:** When you work on the electric range, be careful when handling the sheet metal parts. Sharp edges may be present, and you can cut yourself if you are not careful.

1. Turn off the electrical supply going to the range.
2. Pull the range away from the wall so that you can access the rear panel.
3. Remove the eight screws from the rear panel and remove the panel (see step 4 on page 3-2).

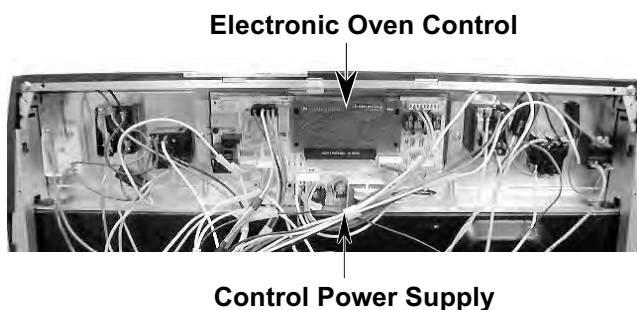

4. To remove the control power supply:
  - a) Disconnect plugs P1 and P2.
  - b) Remove the two screws.

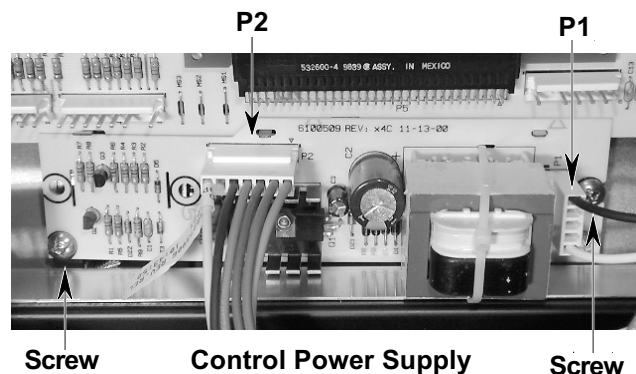

5. To remove the electronic oven control:
  - a) Disconnect plugs P3, P4, P7, and P8.
  - b) Remove the screw, slide the board to the left, and remove it from the bracket clips.

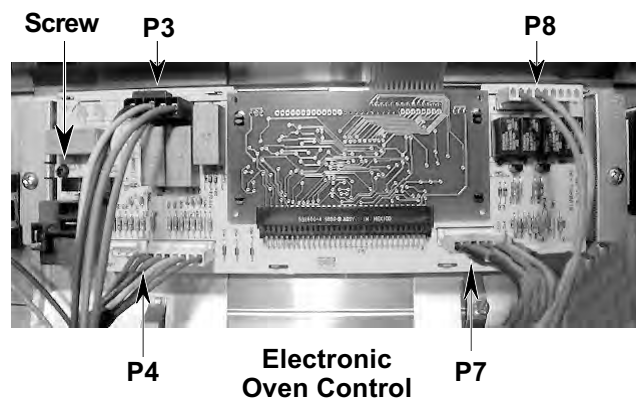

## REMOVING AN ELEMENT & LIMITER AND THE COOKTOP GLASS ASSEMBLY

### **! WARNING**

#### **ELECTRICAL SHOCK HAZARD**

Disconnect power before servicing the range.  
Replace all panels before operating range.  
Failure to do so can result in death or electrical shock.

**CAUTION:** When you work on the electric range, be careful when handling the sheet metal parts. Sharp edges may be present, and you can cut yourself if you are not careful.

1. Turn off the electrical supply going to the range.
2. Open the oven door.
3. Remove the two cooktop bracket screws from the bottom front of the cooktop.



4. Pull the cooktop forward far enough to unhook it from the top of the range.

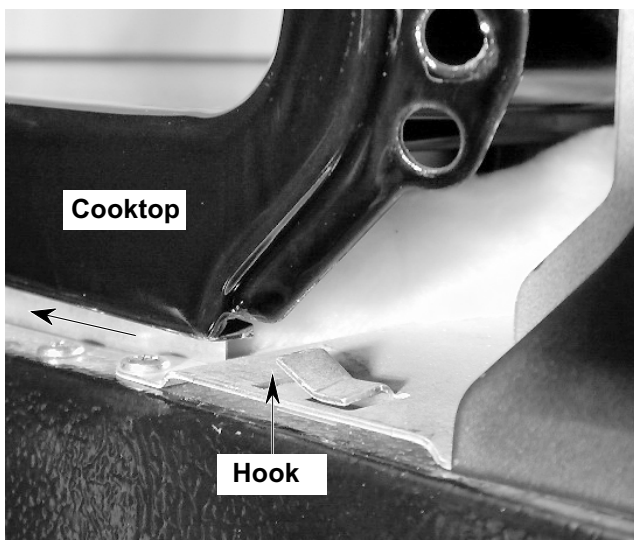

5. Lift the front of the cooktop and rest it against the control panel. **CAUTION:** Be careful that the cooktop does not accidentally fall forward.

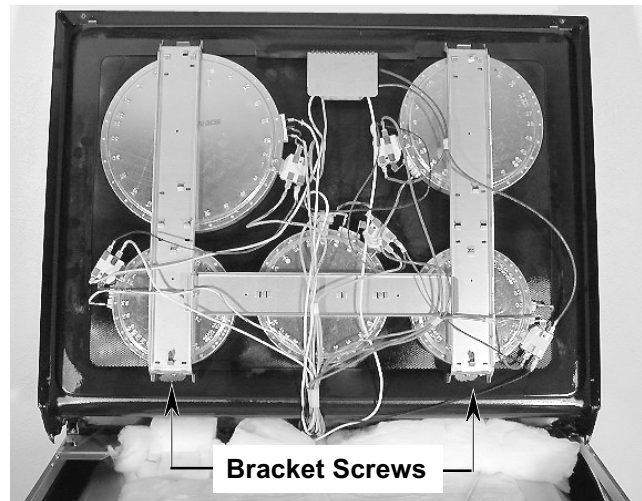

6. **To remove an element and limiter:**

- a) Remove the wires from the element and limiter terminals.
- b) Remove the element bracket screw (shown above) for the element and limiter you are servicing.
- c) If you are removing the center element and limiter, remove the screw from the hot surface indicator bracket and remove the indicator.

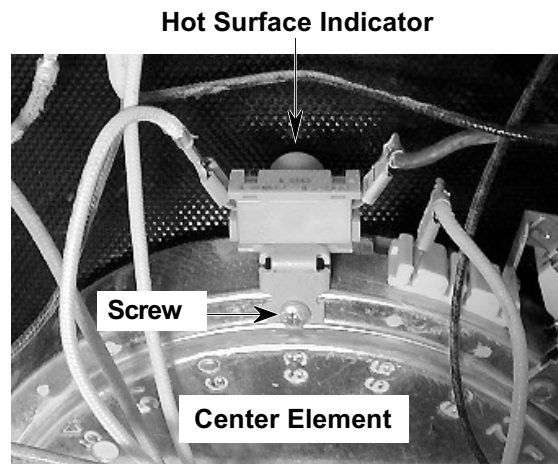



- d) Carefully lift the bottom of the bracket just far enough to remove the element. NOTE: If you are removing an element at the top of the bracket, remove the lower element first, lay it on top of the range, and then remove the top element from the bracket.
- e) Remove the screws from the limiter and remove it from the element. NOTE: Be careful when you remove the limiter that you do not break the sensor tube (see below).

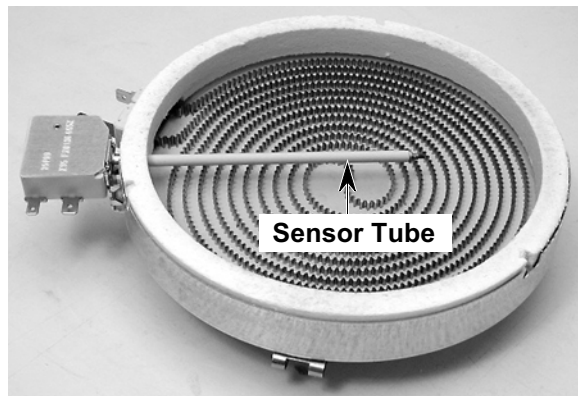
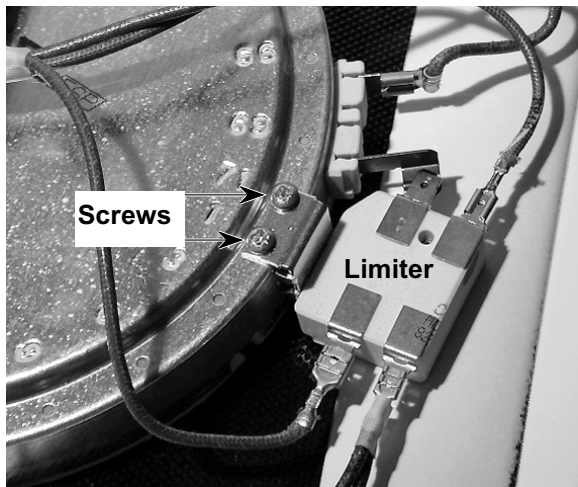

**REASSEMBLY NOTE:** When you reinstall the element and limiter, make sure that the alignment pins are inserted into the correct bracket slots, (see the photo to the right) then reinstall the bracket screw to secure it to the cooktop.

**7. To remove the cooktop glass assembly:**

- a) Remove the two screws from the hot surface indicator assembly bracket and remove the assembly from the frame.

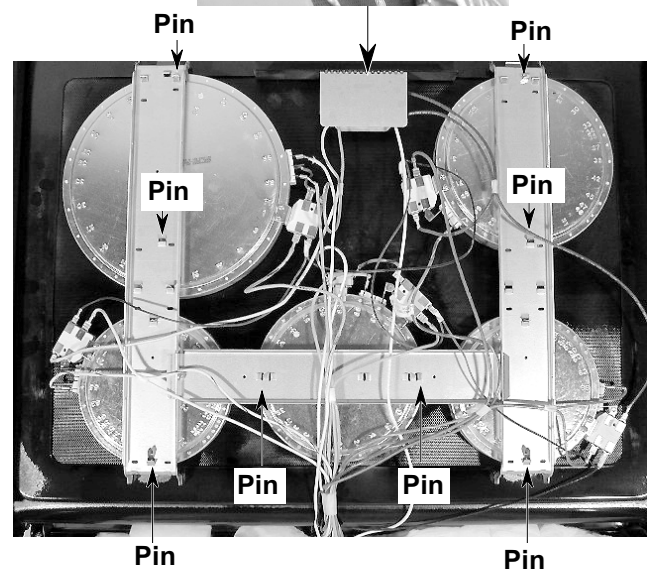
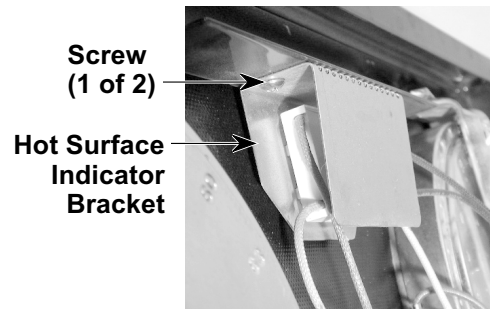

- b) Carefully lift the bottom of the left bracket just far enough to remove the bottom element, then repeat the procedure for the bottom right and center elements. Lay each of the elements on top of the range.
- c) Lift the brackets and remove the top two elements and lay them on top of the range.
- d) Lift the element brackets and unhook them from the top of the cooktop.
- e) Remove the old cooktop glass assembly from the range.

**REASSEMBLY NOTE:** When reinstalling the elements in the new cooktop glass assembly, make sure that the alignment pins are in their correct bracket slots, as shown in the photo above

## REMOVING THE HOT SURFACE INDICATORS

### **! WARNING**

#### **ELECTRICAL SHOCK HAZARD**

Disconnect power before servicing the range.  
Replace all panels before operating range.  
Failure to do so can result in death or electrical shock.

**CAUTION:** When you work on the electric range, be careful when handling the sheet metal parts. Sharp edges may be present, and you can cut yourself if you are not careful.

1. Turn off the electrical supply going to the range.
2. Pull the range away from the wall so that you can access the rear panel.
3. Remove the eight screws from the rear panel and remove the panel (see step 4 on page 3-2).
4. Raise the cooktop (see page 3-8 for the procedure).

#### **(4) Hot Surface Indicator Assembly**

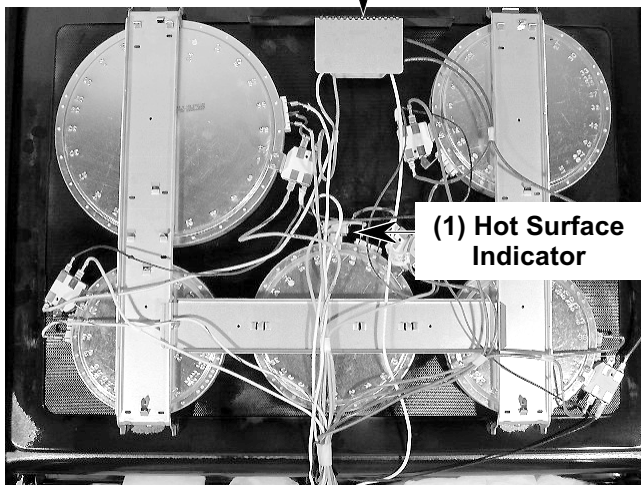

**(1) Hot Surface Indicator**

5. To remove the four hot surface indicator assembly:
  - a) Remove the two screws from the hot surface indicator assembly bracket and remove the assembly from the frame.

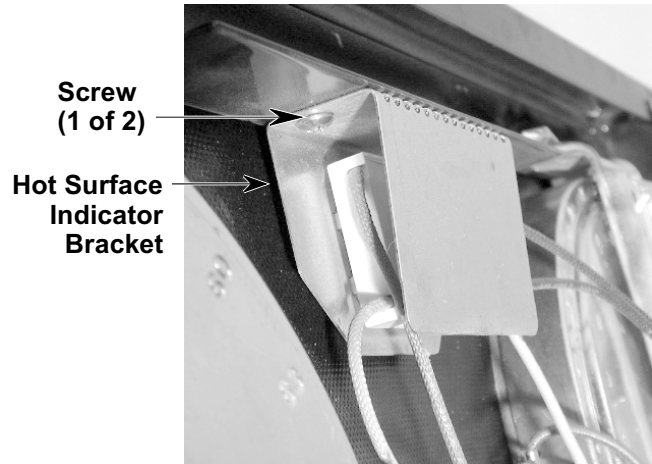

- b) Unsnap four tabs on the hot surface indicator assembly from the bracket and remove the assembly.

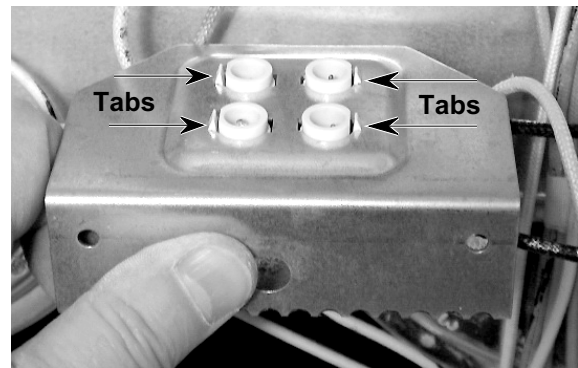

- c) Disconnect the yellow, orange, brown, and blue wires from the element terminals.
- d) From the back of the unit, disconnect the white wire connector.

6. **To remove the single hot surface indicator:**

- a) Remove the screw from the bracket on the center element and remove the indicator.
- b) Disconnect the two wires from the terminals.

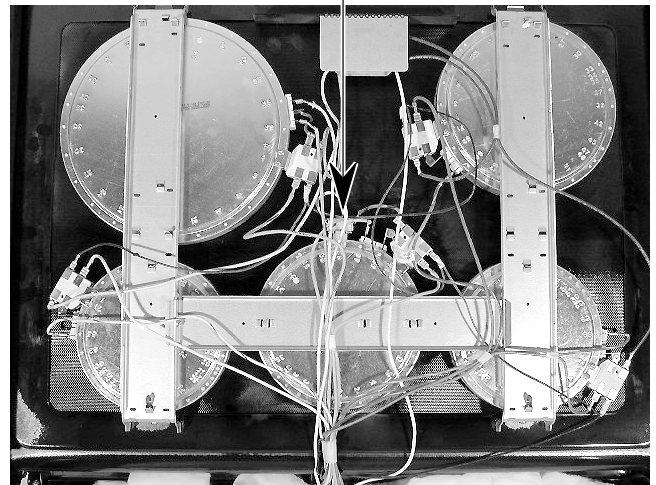
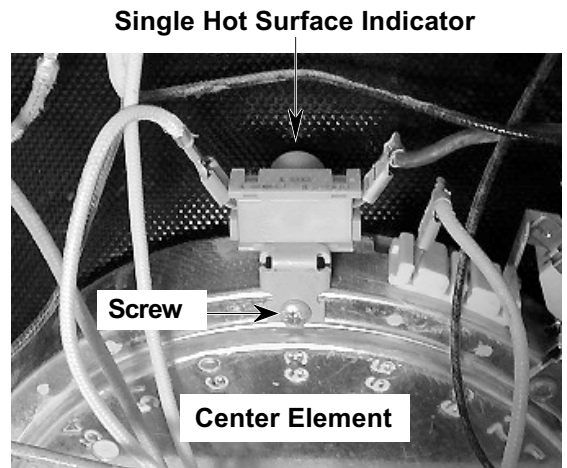

# REMOVING THE DOOR LATCH & THE DOOR SWITCH

## **! WARNING**

### **ELECTRICAL SHOCK HAZARD**

Disconnect power before servicing the range.  
Replace all panels before operating range.  
Failure to do so can result in death or electrical shock.

**CAUTION:** When you work on the electric range, be careful when handling the sheet metal parts. Sharp edges may be present, and you can cut yourself if you are not careful.

1. Turn off the electrical supply going to the range.
2. Open the oven door.
3. Raise the cooktop (see page 3-8 for the procedure).
4. **To remove the door latch:**
  - a) Remove the two screws and rubber bumper from the door latch and remove the latch.

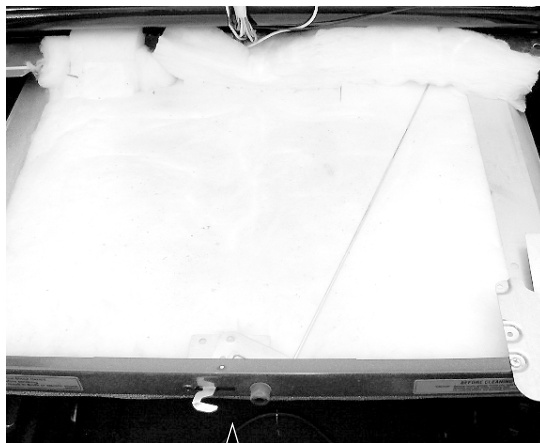

**Screw**      **Screw & Rubber Bumper**

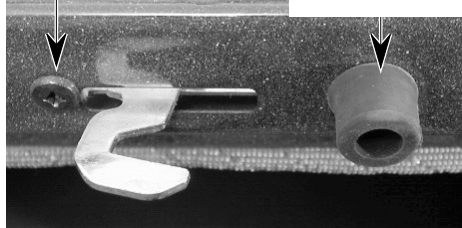

- b) Remove the door latch from the burner box and unhook the actuating rod.

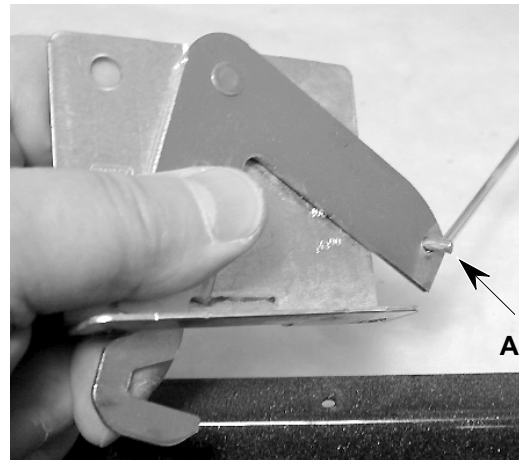

5. **To remove the door switch:**
  - a) If not already done, raise the cooktop (see page 3-8 for the procedure).
  - b) Remove the four screws from the right mounting plate and remove the plate.

**Screw (1 of 4)**      **Right Mounting Plate**

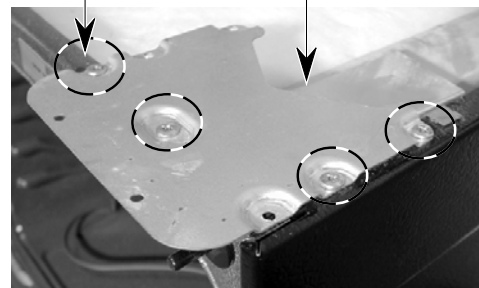

- c) Remove the door switch from the range. To do this, use a ratchet extension or a small socket, and tap it out of the hole with a hammer.

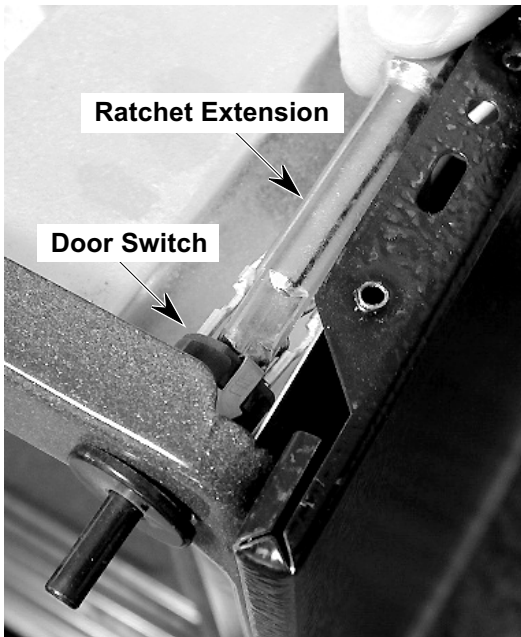

- d) Disconnect the wires from the terminals.

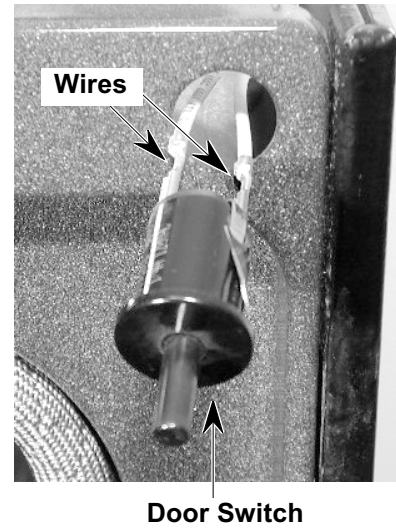

## REMOVING THE BROIL & BAKE ELEMENTS

### **! WARNING**

#### **ELECTRICAL SHOCK HAZARD**

Disconnect power before servicing the range.  
Replace all panels before operating range.  
Failure to do so can result in death or electrical shock.

**CAUTION:** When you work on the electric range, be careful when handling the sheet metal parts. Sharp edges may be present, and you can cut yourself if you are not careful.

1. Turn off the electrical supply going to the range.
2. Open the oven door and remove the racks from inside the oven.
3. **To remove the broil element:**
  - a) Remove the four screws from the front and rear brackets.

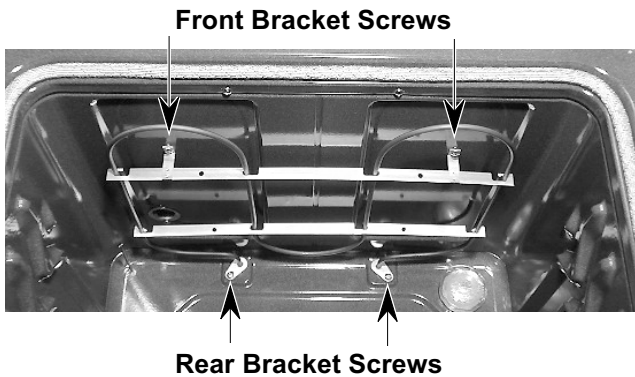

- b) Pull the element forward so that you can access the terminals and disconnect the wires. **NOTE:** The element terminals are at a 90° angle to the rear holes, so be careful when you pull them through the liner holes.

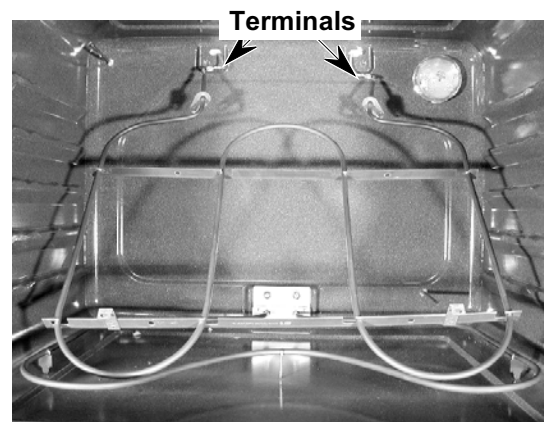
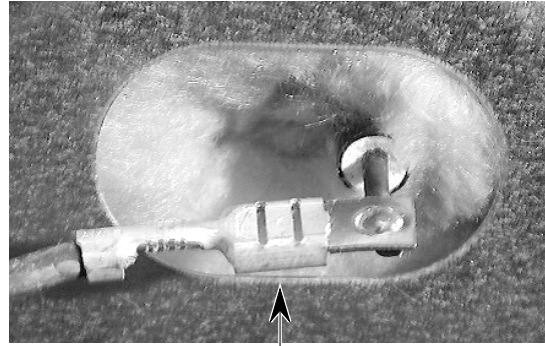

4. **To remove the bake element:**

- a) Remove the two screws from the element brackets.

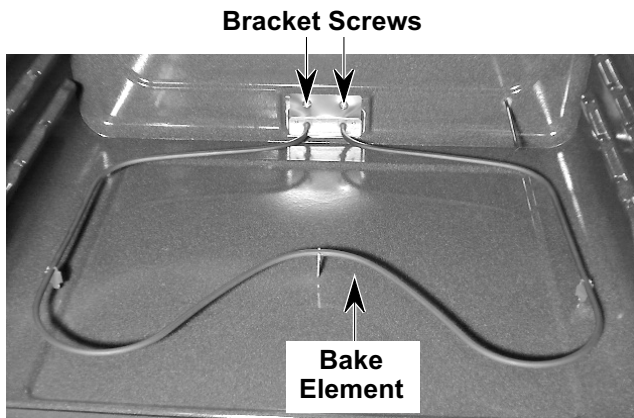

- b) Pull the element forward so that you can access the terminals and disconnect the wires.

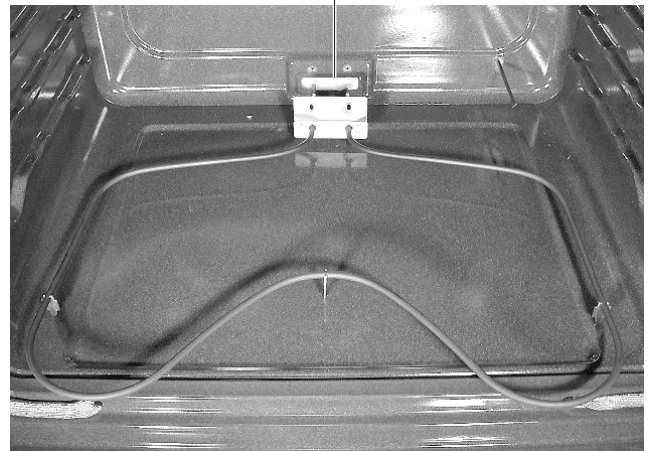
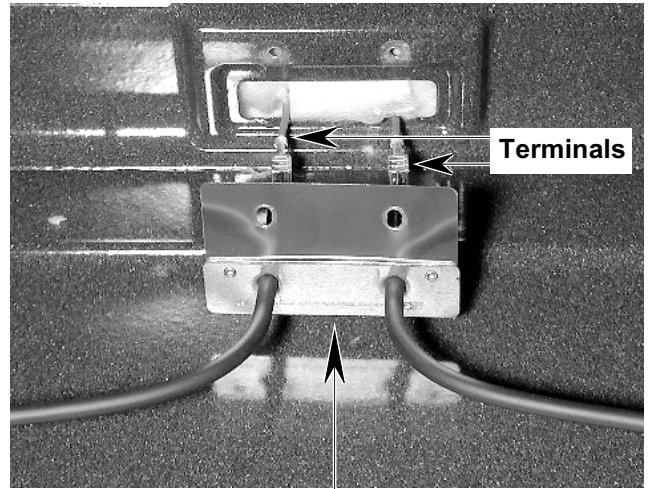

## REMOVING THE OVEN LIGHT SOCKET ASSEMBLY

### **! WARNING**

#### **ELECTRICAL SHOCK HAZARD**

Disconnect power before servicing the range.  
Replace all panels before operating range.  
Failure to do so can result in death or electrical shock.

**CAUTION:** When you work on the electric range, be careful when handling the sheet metal parts. Sharp edges may be present, and you can cut yourself if you are not careful.

1. Turn off the electrical supply going to the range.
2. Open the oven door and remove the racks from the oven.
3. Unscrew the lens and bulb from the oven light socket assembly and remove them.

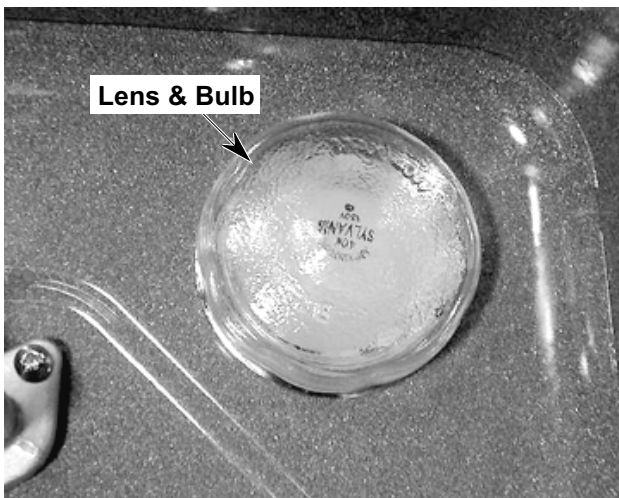

**CAUTION:** Be careful not to scratch or chip the oven liner paint when you remove the oven light socket in the next step.

4. Use a screwdriver and bend the clips on the oven light socket away from the edges of the liner hole, and pull the socket out of the liner. **NOTE:** If it is too difficult to remove the socket from the front of the oven, you will have to push the socket out from the back of the unit.



5. Disconnect the wires from the socket terminals.

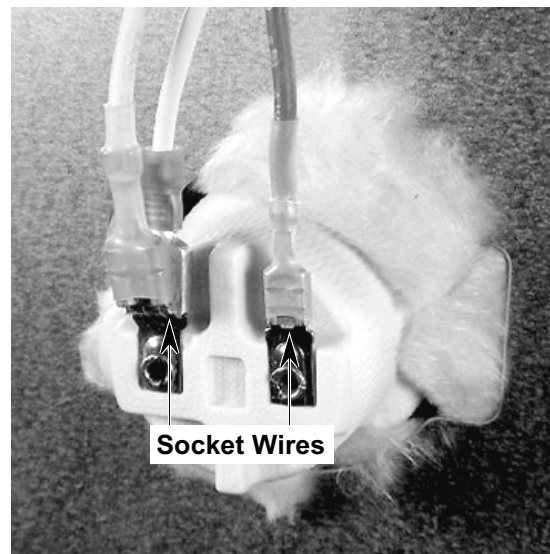

(Viewed From Rear Panel)



## REMOVING THE LATCH DRIVE ASSEMBLY

### **! WARNING**

#### **ELECTRICAL SHOCK HAZARD**

Disconnect power before servicing the range.  
Replace all panels before operating range.  
Failure to do so can result in death or electrical shock.

**CAUTION:** When you work on the electric range, be careful when handling the sheet metal parts. Sharp edges may be present, and you can cut yourself if you are not careful.

1. Turn off the electrical supply going to the range.
2. Open the oven door and remove the racks from the oven.
3. Pull the range away from the wall so that you can access the rear panel.
4. Remove the eight screws from the rear panel and remove the panel (see step 4 on page 3-2).

Latch Drive Assembly

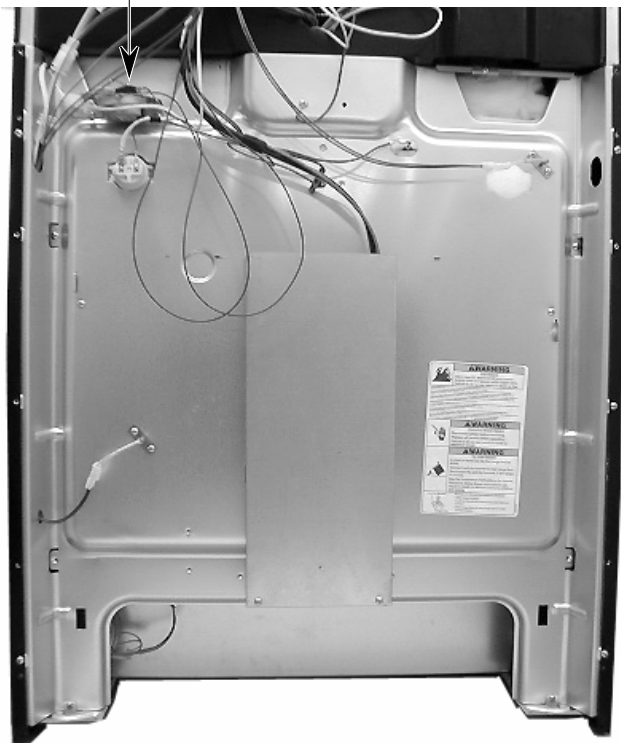

5. Disconnect the wires from the latch drive motor and switch.
6. Remove the two mounting screws from the latch drive.

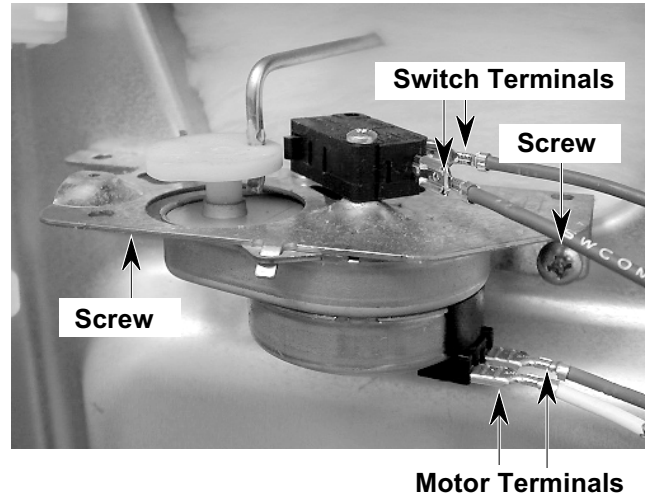

7. Unhook the actuating rod from the cam.

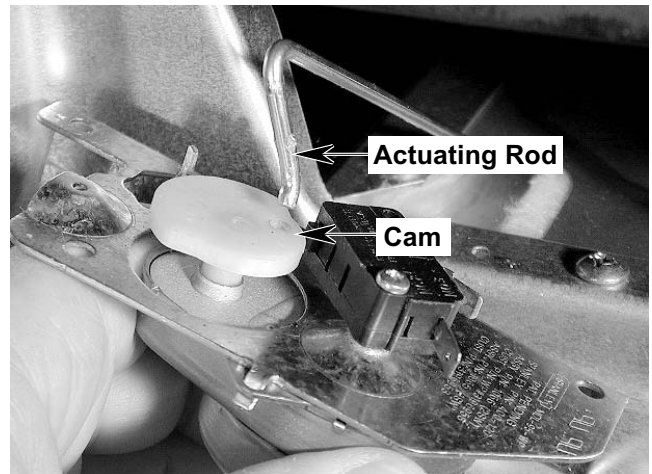

# REMOVING THE OVEN TEMPERATURE SENSORS AND THE THERMAL FUSE

## **! WARNING**

### **ELECTRICAL SHOCK HAZARD**

Disconnect power before servicing the range.  
Replace all panels before operating range.  
Failure to do so can result in death or electrical shock.

**CAUTION:** When you work on the electric range, be careful when handling the sheet metal parts. Sharp edges may be present, and you can cut yourself if you are not careful.

1. Turn off the electrical supply going to the range.
2. Open the oven door and remove the racks from the oven.
3. Pull the range away from the wall so that you can access the rear panel.
4. Remove the eight screws from the rear panel and remove the panel (see step 4 on page 3-2).

5. To remove an oven temperature sensor, disconnect the connector from the main harness and remove the two mounting screws.

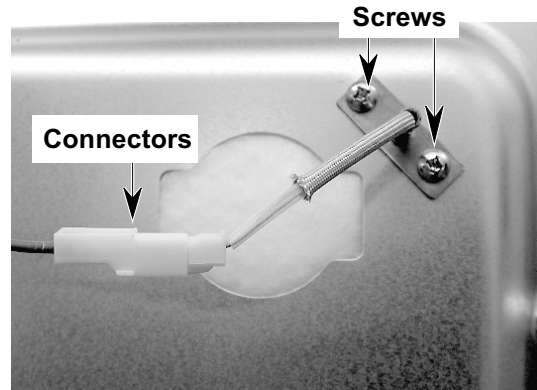

6. To remove the thermal fuse, disconnect the wires from the terminals and remove the mounting screw.

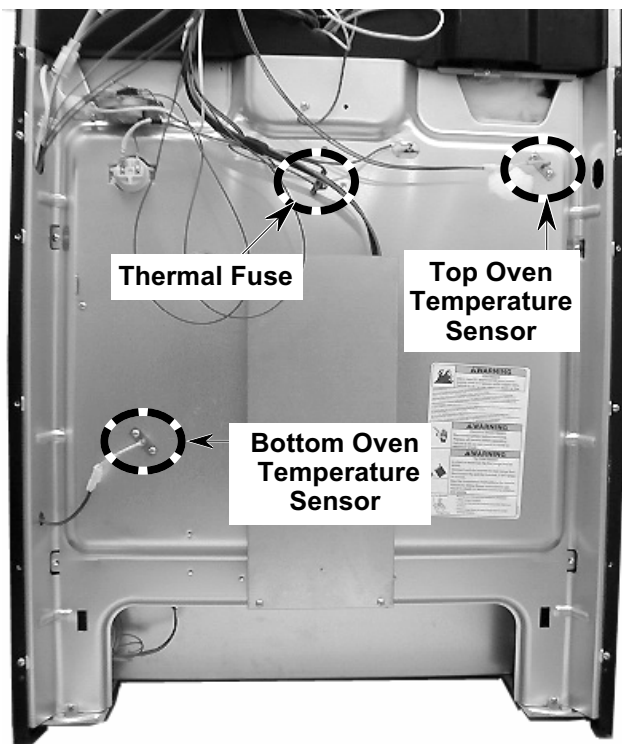
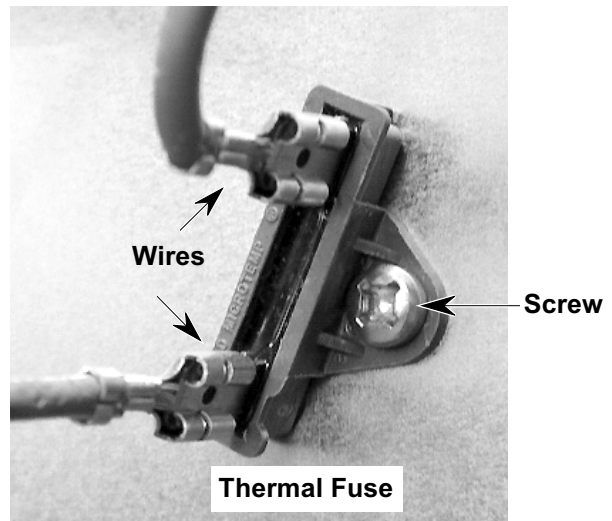

# REMOVING THE WARMING DRAWER ELEMENT & TEMPERATURE SENSOR

## **! WARNING**

### **ELECTRICAL SHOCK HAZARD**

Disconnect power before servicing the range.  
Replace all panels before operating range.  
Failure to do so can result in death or electrical shock.

**CAUTION:** When you work on the electric range, be careful when handling the sheet metal parts. Sharp edges may be present, and you can cut yourself if you are not careful.

1. Turn off the electrical supply going to the range.
2. Slide the warming drawer out as far as it will go, press on the release arms, located on the side rails of the drawer, and remove the drawer.

Release Arm  
(on each side)



Warming Drawer

3. **To remove the warming drawer element:**
  - a) Remove the two front bracket screws (see the photo at the top of the next column).

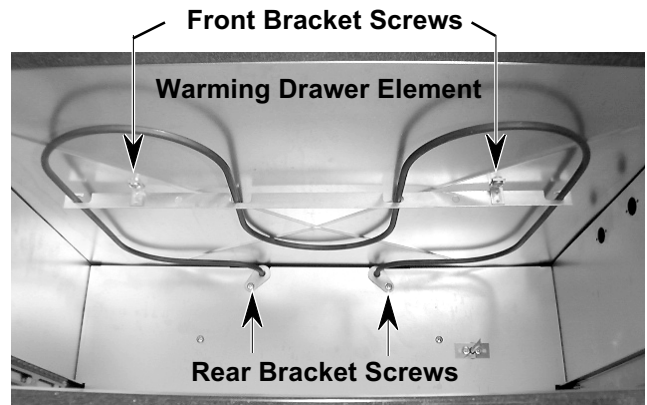

- b) Remove the two rear bracket screws, pull the element forward, and disconnect the wires from the terminals.
4. **To remove the warming drawer temperature sensor:**
    - a) If not already done, remove the warming drawer (see step 2).
    - b) Remove the two mounting screws from the sensor bracket.



Warming Drawer  
Temperature Sensor Screws

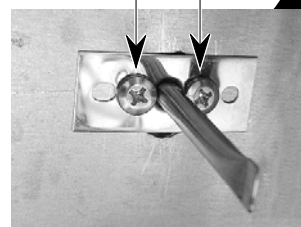

- c) Pull the sensor forward and unplug the connectors.

## REMOVING THE OVEN DOOR

### **! WARNING**

#### **ELECTRICAL SHOCK HAZARD**

Disconnect power before servicing the range.  
Replace all panels before operating range.  
Failure to do so can result in death or electrical shock.

**CAUTION:** When you work on the electric range, be careful when handling the sheet metal parts. Sharp edges may be present, and you can cut yourself if you are not careful.

**CAUTION:** Do not lift the oven door by its handle.

#### **To remove the oven door:**

1. Open the oven door to its fully down position.
2. Remove the two door stop clips from the oven door slots.

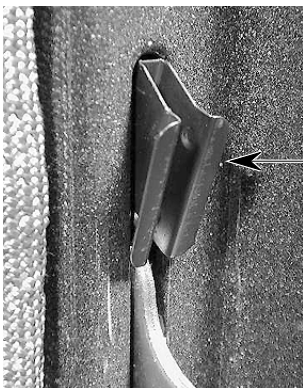

**Door Stop Clip**

3. Install a pin in the hole of each oven door hinge hanger.

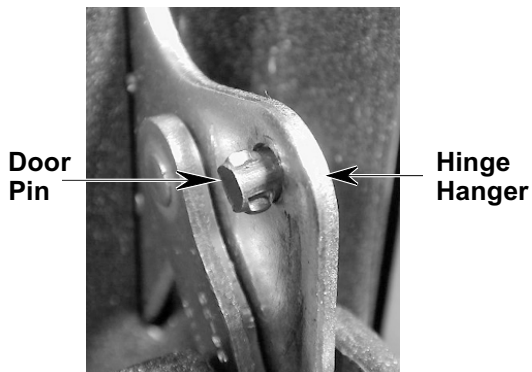

**Door Pin**

**Hinge Hanger**

4. Close the oven door as far as the two pins will allow.
5. Grasp the sides of the door and lift the door until it stops, then pull the hinge hangers out of the slots.



**Hinge Hanger**

#### **To reinstall the oven door:**

1. Grasp the sides of the door and tilt it back at a slight angle, then insert the hinge hangers into the hinge slots as far as they will go.
2. Rotate the top of the door towards the range so the hinge hangers fit onto the support pins.
3. Close the oven door as far as the pins will allow, and make sure that the hinge hangers are fully seated on the support pins. If they are not seated properly, the door will not close tightly and may be off-center. To seat the hinge hangers, open the door slightly, and push in on the bottom until the hangers are fully seated.
4. Open the oven door to its fully open position and remove the two hinge hanger pins.

5. Install the two door stop clips in the top of the door slots with the angled side facing up.

**Angled Side up**



6. Close the oven door completely and check it for proper operation and alignment.

## REMOVING THE OVEN DOOR HANDLE & GLASS

### **! WARNING**

#### **ELECTRICAL SHOCK HAZARD**

Disconnect power before servicing the range.  
Replace all panels before operating range.  
Failure to do so can result in death or electrical shock.

**CAUTION:** When you work on the electric range, be careful when handling the sheet metal parts. Sharp edges may be present, and you can cut yourself if you are not careful.

1. Remove the oven door from the range (see page 3-20 for the procedure).
2. Place the oven door on a padded work surface with the front glass facing down.
3. Remove the two top door liner screws.



4. Remove the three bottom screws from the door liner.

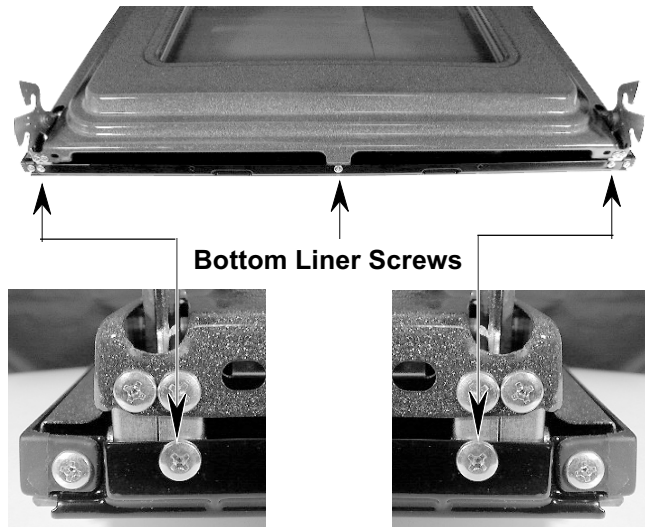

5. Lift the liner assembly off the front glass and set it aside.
6. **To remove the door handle**, unhook it from the top of the front glass and remove the two door handle screws.



7. **To remove the front door glass**, remove the two side trim screws. Be careful not to break the trim near the mounting screw.

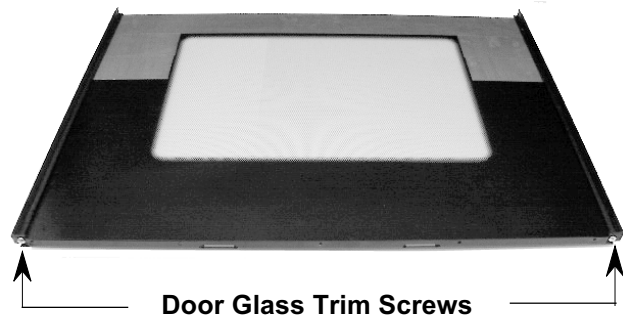

8. **To remove a hinge hanger assembly:**

- a) Place the door liner assembly on a padded work surface with the hinge hangers over the edge.
- b) Remove the two bottom screws.
- c) Unhook the hinge hanger tab from the slot at the top.
- d) Lift the hinge hanger out of the door liner slot.

Unhook Tab From Slot

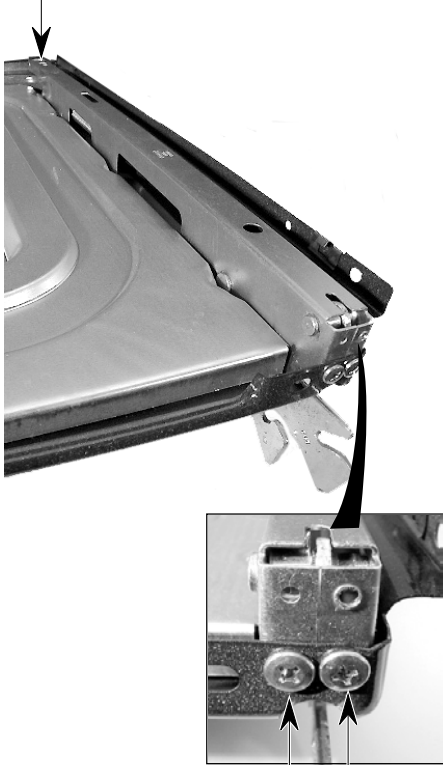

Hinge Hanger Screws

9. **To remove the oven door glass assembly:**

- a) Remove both hinge hangers (see step 8).
- b) Lift the insulation retainer off the door liner.



- c) Remove the insulation from around the oven door glass assembly.

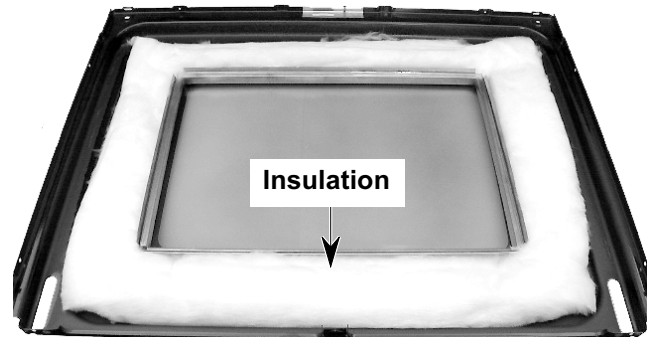

- d) Lift the inner oven door glass and bracket assembly out of the door liner.



- e) Lift the outer oven door glass out of the door liner.

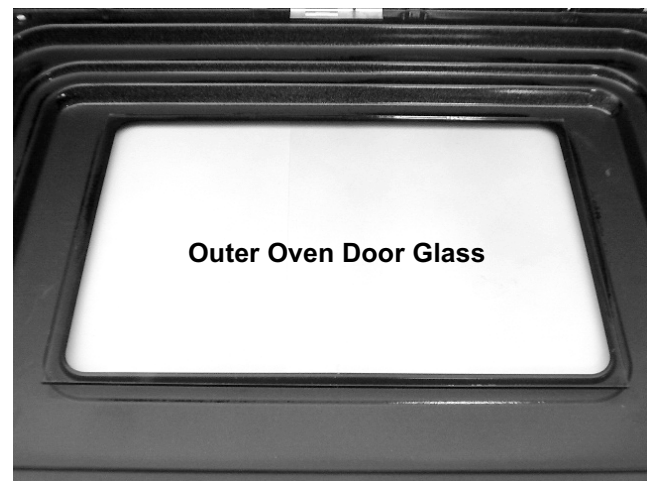

**REASSEMBLY NOTE:** When you reinstall the insulation around the oven door glass, make sure that the insulation is not visible in the glass after the door is reassembled.

## REMOVING THE OVEN DOOR GASKET

### **! WARNING**

#### **ELECTRICAL SHOCK HAZARD**

Disconnect power before servicing the range.  
Replace all panels before operating range.  
Failure to do so can result in death or electrical shock.

**CAUTION:** When you work on the electric range, be careful when handling the sheet metal parts. Sharp edges may be present, and you can cut yourself if you are not careful.

1. Open the oven door to its fully down position.
2. Pull the oven door gasket clips out of the liner holes until all of the clips are removed.

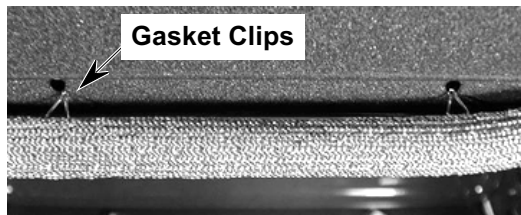
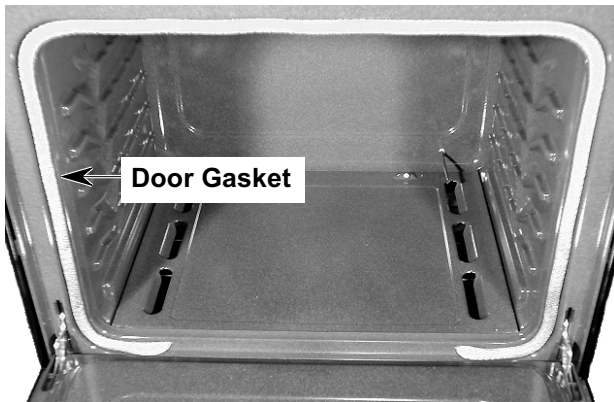

3. Pull the ends of the gasket out of the liner holes.



**REASSEMBLY NOTE:** When you install the new gasket, make sure that all of the clips are seated in their liner holes, and that the ends of the gasket are pushed fully into their holes. Use the pointed end of a pencil to push the gasket ends into the holes.

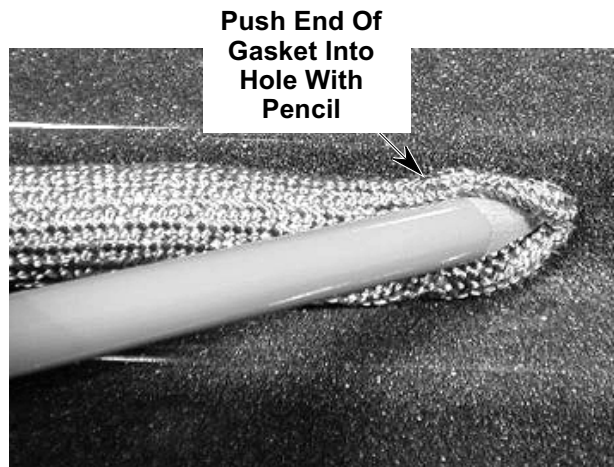



## REMOVING A SIDE PANEL

### **! WARNING**

#### **ELECTRICAL SHOCK HAZARD**

Disconnect power before servicing the range.  
Replace all panels before operating range.  
Failure to do so can result in death or electrical shock.

**CAUTION:** When you work on the electric range, be careful when handling the sheet metal parts. Sharp edges may be present, and you can cut yourself if you are not careful.

1. Turn off the electrical supply going to the range.
2. Remove the oven door from the range (see page 3-20 for the procedure).
3. Pull the range away from the wall so you can access the back of the unit.
4. Remove the eight screws from the rear panel and remove the panel (see step 4 on page 3-2).
5. Raise the cooktop (see page 3-8 for the procedure). **NOTE:** Position the side of the cooktop so that it does not rest on the side panel that you are removing.
6. Remove the five screws from the top of the side panel. **NOTE:** Set the small support bracket aside with the screws.

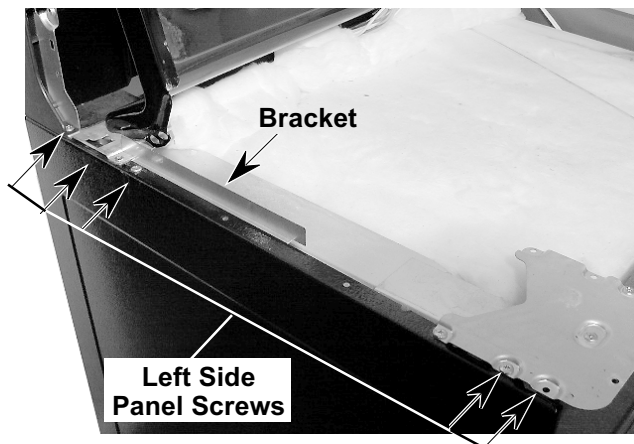

7. Remove the three screws from the left or right side panel you are removing (the left panel is shown below).

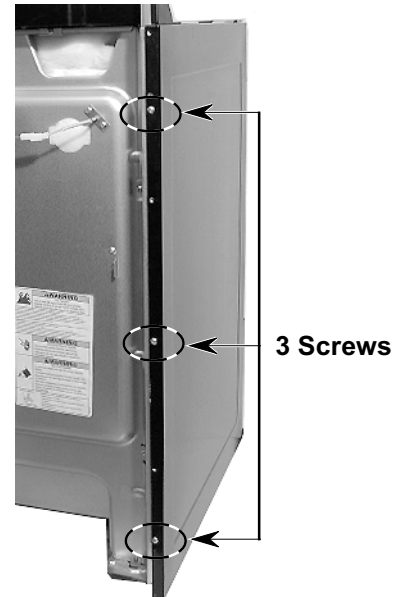

8. Pull the back of the side panel out from the range approximately 45°.



9. Open the warming drawer several inches.
10. Push forward and unhook the three front tabs from the chassis slots and remove the side panel.

— NOTES —

# COMPONENT TESTING

Before testing any of the components, perform the following checks:

- The most common cause for control failure is corrosion on connectors. Therefore, disconnecting and reconnecting wires will be necessary throughout test procedures.
- All tests/checks should be made with a VOM or DVM having a sensitivity of 20,000 ohms-per-volt DC, or greater.

- Check all connections before replacing components, looking for broken or loose wires, failed terminals, or wires not pressed into connectors far enough.
- Resistance checks must be made with power cord unplugged from outlet, and with wiring harness or connectors disconnected.

## **! WARNING**

### **ELECTRICAL SHOCK HAZARD**

Disconnect power before servicing.  
Replace all panels before operating.  
Failure to do so could result in death or electrical shock.

## **! WARNING**

### **ELECTRICAL SHOCK HAZARD**

Disconnect power before servicing.  
Replace all panels before operating.  
Failure to do so could result in death or electrical shock.

### **DOOR SWITCH**



Refer to page 3-12 for the procedure for servicing the door switch.

1. Disconnect the electrical power to the range.
2. Set the ohmmeter to the R x 1 scale.
3. Touch the ohmmeter leads to the door switch terminals. The meter should indicate an open circuit (infinite).
4. Press the actuator button and the meter should indicate continuity (0  $\Omega$ ).

### **WARMING DRAWER ELEMENT**

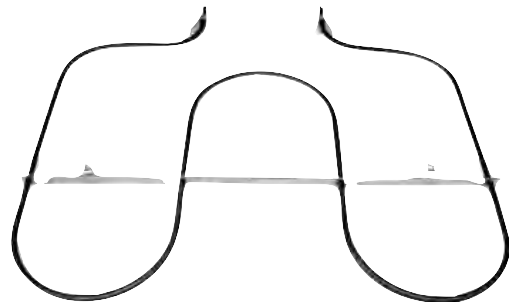

Refer to page 3-19 for the procedure for servicing the warming drawer element.

1. Disconnect the electrical power to the range.
2. Set the ohmmeter to the R x 1 scale.
3. Touch one of the ohmmeter leads to the warming drawer element terminals. The meter should indicate between 14 and 20  $\Omega$ .

# **! WARNING**

## **ELECTRICAL SHOCK HAZARD**

Disconnect power before servicing.  
Replace all panels before operating.  
Failure to do so could result in death or electrical shock.

### **BAKE ELEMENT**

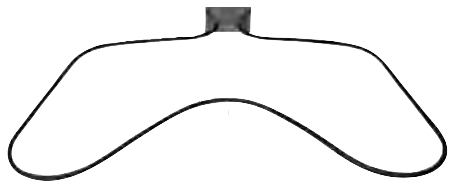

Refer to page 3-14 for the procedure for servicing the bake element.

1. Disconnect the electrical power to the range.
2. Set the ohmmeter to the R x 1 scale.
3. Touch one of the ohmmeter leads to the bake element terminals. The meter should indicate between 20 and 28  $\Omega$ .

# **! WARNING**

## **ELECTRICAL SHOCK HAZARD**

Disconnect power before servicing.  
Replace all panels before operating.  
Failure to do so could result in death or electrical shock.

### **BROIL ELEMENT**

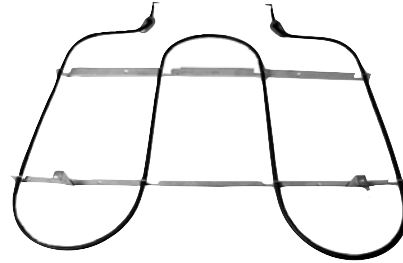

Refer to page 3-14 for the procedure for servicing the broil element.

1. Disconnect the electrical power to the range.
2. Set the ohmmeter to the R x 1 scale.
3. Touch one of the ohmmeter leads to the broil element terminals. The meter should indicate between 14 and 21  $\Omega$ .

# ! WARNING

## ELECTRICAL SHOCK HAZARD

Disconnect power before servicing.  
Replace all panels before operating.  
Failure to do so could result in death or electrical shock.

## LATCH DRIVE

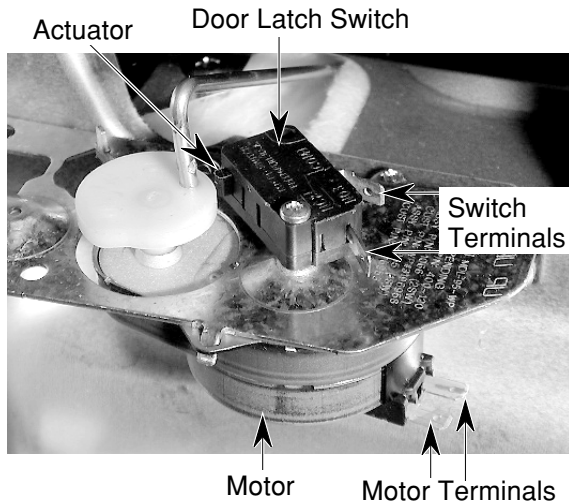

Refer to page 3-17 for the procedure for servicing the latch drive.

1. Disconnect the electrical power to the range.
2. Disconnect the wires from the latch drive component under test.
3. Set the ohmmeter to the R x 1K scale.
4. **To test the motor**, touch the ohmmeter leads to the terminals. The meter should indicate approximately 2800  $\Omega$ .
5. **To test the door latch switch:**
  - a) Touch the ohmmeter leads to the terminals. The meter should indicate an open circuit (infinite).
  - b) Press the switch actuator and touch the ohmmeter leads to the terminals. The meter should indicate continuity (0  $\Omega$ ).

# ! WARNING

## ELECTRICAL SHOCK HAZARD

Disconnect power before servicing.  
Replace all panels before operating.  
Failure to do so could result in death or electrical shock.

## OVEN & WARMING DRAWER TEMPERATURE SENSORS



Refer to page 3-18 for the procedure for servicing the oven temperature sensors, and to page 3-19 for the warming drawer temperature sensor.

1. Disconnect the electrical power to the range.
2. Set the ohmmeter to the R x 100 scale.
3. Touch the ohmmeter test leads to the oven temperature sensor connector pins. The meter should indicate approximately 1080  $\Omega$  at 75°F for both sensors.
4. Set the ohmmeter to the R x 10K scale.
5. Touch the ohmmeter test leads to the warming drawer temperature sensor connector pins. The meter should indicate approximately 9 k $\Omega$  at 75°F.

# ! WARNING

## ELECTRICAL SHOCK HAZARD

Disconnect power before servicing.  
Replace all panels before operating.  
Failure to do so could result in death or electrical shock.

### THERMAL FUSE



Refer to page 3-18 for the procedure for servicing the thermal fuse.

1. Disconnect the electrical power to the range.
2. Set the ohmmeter to the R x 1 scale.
3. Touch one of the ohmmeter leads to the thermal fuse terminals. The meter should indicate continuity (0  $\Omega$ ). NOTE: The thermal fuse will open at 363°F (184°C) and is non-resettable.

# ! WARNING

## ELECTRICAL SHOCK HAZARD

Disconnect power before servicing.  
Replace all panels before operating.  
Failure to do so could result in death or electrical shock.

### SINGLE ELEMENT INFINITE SWITCHES (RF, RR, & LR)

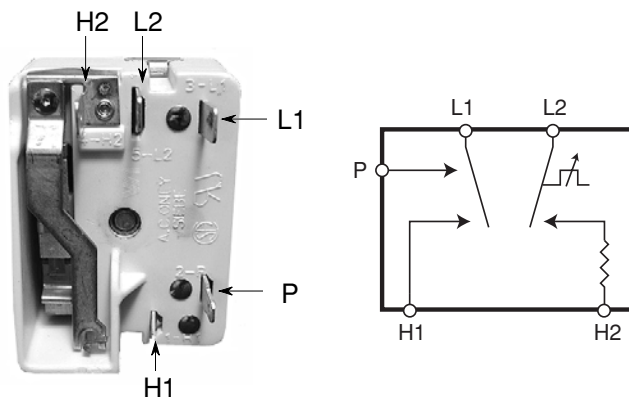

Refer to page 3-2 for the procedure for servicing a single element infinite switch.

1. Disconnect the electrical power to the range.
2. Set the ohmmeter to the R x 1 scale.
3. Turn the appropriate infinite switch to the On position.
4. Touch the ohmmeter test leads to terminals L1 and P. The meter should indicate continuity (0  $\Omega$ ).
5. Touch the ohmmeter test leads to terminals L1 and H1. The meter should indicate continuity (0  $\Omega$ ).
6. Touch the ohmmeter test leads to terminals L2 and H2. The meter should indicate continuity (0  $\Omega$ ).

# ! WARNING

## ELECTRICAL SHOCK HAZARD

Disconnect power before servicing.  
Replace all panels before operating.  
Failure to do so could result in death or electrical shock.

## DUAL ELEMENT INFINITE SWITCH (LF)

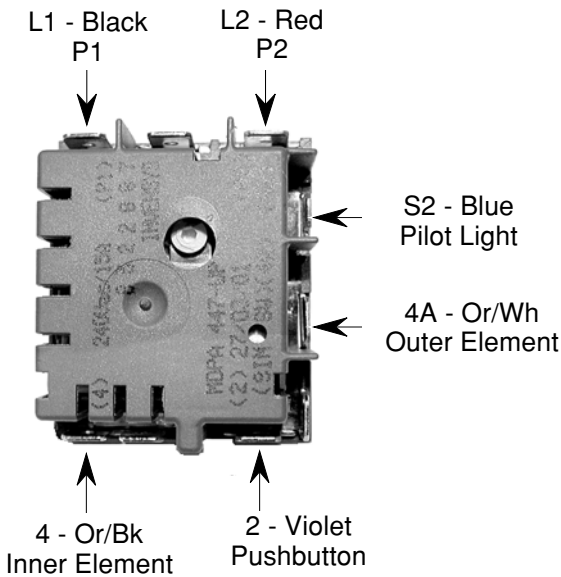

Refer to page 3-4 for the procedure for servicing the dual element infinite switch.

1. Disconnect the electrical power to the range.
2. Set the ohmmeter to the R X 1 scale.
3. Turn the dual element infinite switch to the "single" position.

4. Touch the ohmmeter test leads to the following terminals. The meter should indicate continuity ( $0 \Omega$ ):
  - a) P1 - 4.
  - b) P1 - S2.
  - c) P2 - 2.
5. Touch the ohmmeter test leads to terminals P1 and 4a. The meter should indicate an open circuit (infinite).

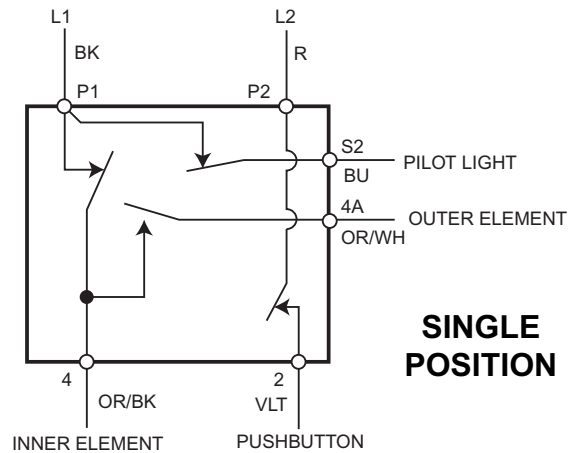

6. Turn the dual element infinite switch to the "dual" position.
7. Touch the ohmmeter test leads to the following terminals. The meter should indicate continuity ( $0 \Omega$ ):
  - a) P1 - 4.
  - b) P1 - 4a.
  - c) P1 - S2.
  - d) P2 - 2.

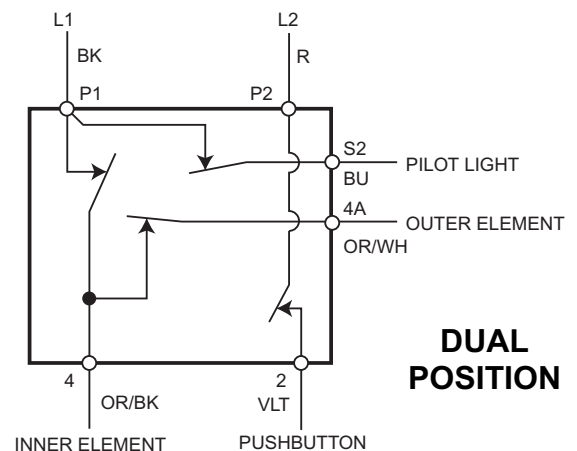

# ! WARNING

## ELECTRICAL SHOCK HAZARD

Disconnect power before servicing.  
Replace all panels before operating.  
Failure to do so could result in death or electrical shock.

## KEEP WARM SWITCH (CR)

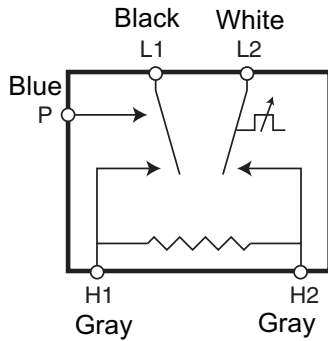
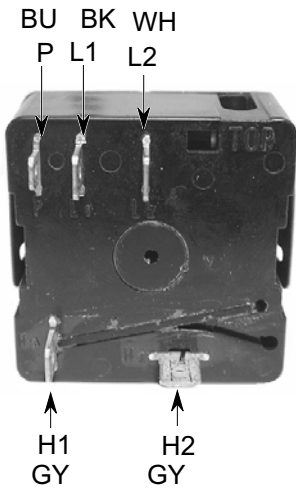

Refer to page 3-5 for the procedure for servicing the Keep Warm switch.

1. Disconnect the electrical power to the range.
2. Set the ohmmeter to the R X 1K scale.
3. Turn the Keep Warm switch to the On position.
4. Touch the ohmmeter test leads to terminals L1 and P. The meter should indicate continuity (0  $\Omega$ ).
5. Touch the ohmmeter test leads to terminals L1 and H1. The meter should indicate continuity (0  $\Omega$ ).
6. Touch the ohmmeter test leads to terminals L2 and H2. The meter should indicate continuity (0  $\Omega$ ).



# ! WARNING

## ELECTRICAL SHOCK HAZARD

Disconnect power before servicing.  
Replace all panels before operating.  
Failure to do so could result in death or electrical shock.

## NORMAL BURNER/ACCUSIMMER SWITCH (LF)

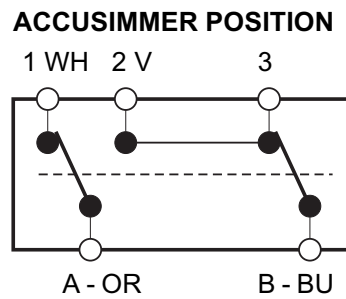
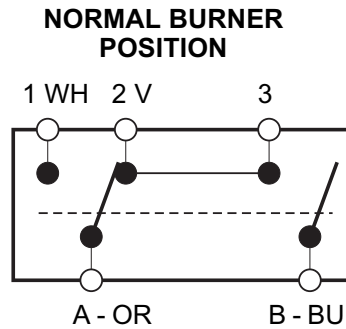
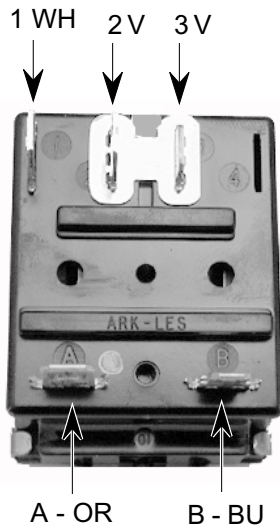

Refer to page 3-3 for the procedure for servicing the Normal Burner/AccuSimmer switch.

1. Disconnect the electrical power to the range.
2. Set the ohmmeter to the R x 1 scale.
3. Turn the Normal Burner/AccuSimmer switch to the Normal Burner position.
4. Touch the ohmmeter test leads to terminals 2 and A. The meter should indicate continuity (0  $\Omega$ ).
5. Touch the ohmmeter test leads to terminals 3 and A. The meter should indicate continuity (0  $\Omega$ ).
6. Touch the ohmmeter test leads to terminals 1 and A. The meter should indicate an open (infinite) circuit.
7. Turn the Normal Burner/AccuSimmer switch to the AccuSimmer position.
8. Touch the ohmmeter test leads to terminals 1 and A. The meter should indicate continuity (0  $\Omega$ ).
9. Touch the ohmmeter test leads to terminals 2 and B. The meter should indicate continuity (0  $\Omega$ ).
10. Touch the ohmmeter test leads to terminals 3 and B. The meter should indicate continuity (0  $\Omega$ ).

# ⚠ WARNING

## ELECTRICAL SHOCK HAZARD

Disconnect power before servicing.  
Replace all panels before operating.  
Failure to do so could result in death or electrical shock.

## SURFACE ELEMENTS & LIMITERS

Refer to page 3-8 for the procedure for servicing the elements & limiters.

1. Disconnect the electrical power to the range.
2. Set the ohmmeter to the R X 1 scale.
3. Raise the cooktop.
4. **To test the RF, LR, & RR elements & limiters:**
  - a) Disconnect one of the wires from the element terminals.
  - b) Disconnect the wires from limiter terminals 1A and 1B.
  - c) Touch the ohmmeter test leads to the two element terminals. The meter should indicate  $45\ \Omega \pm 10\%$ .
  - d) Touch the ohmmeter test leads to limiter terminals 1A & 2A. The meter should indicate continuity (0  $\Omega$ ).

- e) Touch the ohmmeter test leads to limiter terminals 1B & 2B.  
With the temperature below 150°F, the meter should indicate an open circuit (infinite).

With the temperature above 150°F, the meter should indicate continuity (0  $\Omega$ ).

### 5. **To test the center rear (CR) element and limiter:**

- a) Disconnect either of the gray wires from the element terminals.
- b) Disconnect the wires from limiter terminals 1A and 1B.
- c) Touch the ohmmeter test leads to the two element terminals. The meter should indicate  $120\ \Omega \pm 10\%$ .
- d) Touch the ohmmeter test leads to limiter terminals 1A & 2A. The meter should indicate continuity (0  $\Omega$ ).

- e) Touch the ohmmeter test leads to limiter terminals 1B & 2B.

With the temperature below 150°F, the meter should indicate an open circuit (infinite).

With the temperature above 150°F, the meter should indicate continuity (0  $\Omega$ ).

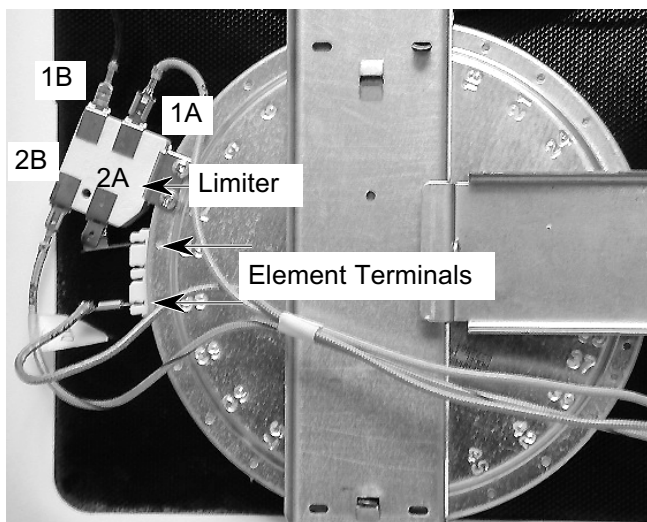

6. **To test the left front (LF) dual element and limiter:**

- a) Disconnect the wires from the dual element terminals.
- b) Disconnect the wires from limiter terminals 1A and 1B.
- c) Touch the ohmmeter test leads to the 800W element terminals (orange/white wire). The meter should indicate  $50 \Omega \pm 10\%$ .
- d) Touch the ohmmeter test leads to the 1600W element terminals (orange/black wire). The meter should indicate  $38 \Omega \pm 10\%$ .

e) Touch the ohmmeter test leads to limiter terminals 1A & 2A. The meter should indicate continuity ( $0 \Omega$ ).

f) Touch the ohmmeter test leads to limiter terminals 1B & 2B.

With the temperature below  $150^{\circ}\text{F}$ , the meter should indicate an open circuit (infinite).

With the temperature above  $150^{\circ}\text{F}$ , the meter should indicate continuity ( $0 \Omega$ ).

— NOTES —

# DIAGNOSIS & TROUBLESHOOTING

## FAILURE/ERROR DISPLAY CODES TECH SHEET 8522647, REV. A

- All diagnoses of this range must begin with a normal check of the line voltage, blown fuses, and failed components.
- All units that have failed during the first few days of use, should be checked for loose connections, or miswiring.
- All checks should be made with a meter having a sensitivity of 20,000 ohms per volt, or greater.

4-DIGIT DISPLAY	3-DIGIT DISPLAY	LIKELY FAILURE CONDITION	SUGGESTED CORRECTIVE ACTION PROCEDURE
F0	E0	Factory default - not an error	1. No action required.
F1	E0	EEPROM communications error	1. Verify failure if not displayed, using CANCEL/OFF key. Press key for 5 seconds until last error code is displayed. 2. Disconnect power longer than 30 seconds. 3. Re-apply power and observe for longer than 1 minute. 4. If failure remains, disconnect power, replace control.
	E1	EEPROM checksum error	
	E2	UL A/D error(s)	
	E4	Model ID error	
F2	E6	Latch signal mismatch error	1. Verify failure if not displayed, using CANCEL/OFF key. Press for 5 seconds. 2. Disconnect power. 3. If applicable, ensure membrane tail is seated in connector on back of control. 4. Re-apply power and observe for longer than 1 minute. 5. If failure remains, disconnect power, replace control.
	E0	Shorted key	
F3	E1	Key tail unplugged	1. Measure sensor value (between connector pins) between 1000 $\Omega$ @ 32° F and 2697 $\Omega$ @ 900° F (room temperature approx. = 1080 $\Omega$ ). If measurement does not correlate to real temperature, disconnect power, replace sensor and refer to steps 3-5. Also measure from sensor connector to sensor casing for possible short. 2. Trace wires and connectors to sensor from control, then from sensor back to control. If all connections are made and no wire damage, refer to step 3. 3. Disconnect power longer than 30 seconds. 4. Re-apply power and observe for longer than 1 minute. 5. If failure remains, disconnect power, replace control, then go back to step 4.
	E0	Oven sensor opened - Top	
	E1	Oven sensor shorted - Top	
	E2	Bake range over temperature	
	E3	Clean range over temperature	
F3	E4	Oven sensor opened - Bottom	1. Same corrective action as for other F3 codes, with the exception that the warming drawer resistance value at room temperature is approx. 100k $\Omega$ .
	E5	Oven sensor shorted - Bottom	
F3	E6	Warming drawer sensor open	
	E7	Warming drawer sensor shorted	
F5	E0	Door switches do not agree	1. Disconnect power from unit. 2. Check wires and connectors from control to door switch, then from door switch to control. 3. If no damage to wires or connector, replace door switch. 4. Re-apply power. 5. Press CANCEL PROGRAM and start the clean mode, and observe for one minute to ensure that operation is normal.
F5	E1	Door latch not operating	1. Verify error code by pressing and holding CANCEL/OFF key for 5 seconds. Momentarily (less than 5 sec.) press CANCEL key again to remove error code display. 2. Program and start the Clean mode. Observe to see if door locks. If it does not, inspect the locking mechanism from the solenoid to the latch pawl and door to find the cause of the problem. If the door is not locking, then 1 minute from the start of the Clean, the F5 E1 code will again be displayed. Press CANCEL key to remove error code display. 3. Once any mechanical problems with the latch mechanism have been corrected, program and start a Clean cycle (after, if necessary, clearing F5 E1 error code) to ensure proper operation of the door lock. Immediately cancel the Clean mode to observe proper operation of door unlock.
F8	E0	N/A	N/A

— NOTES —

# WIRING DIAGRAMS & STRIP CIRCUITS

## WIRING DIAGRAM

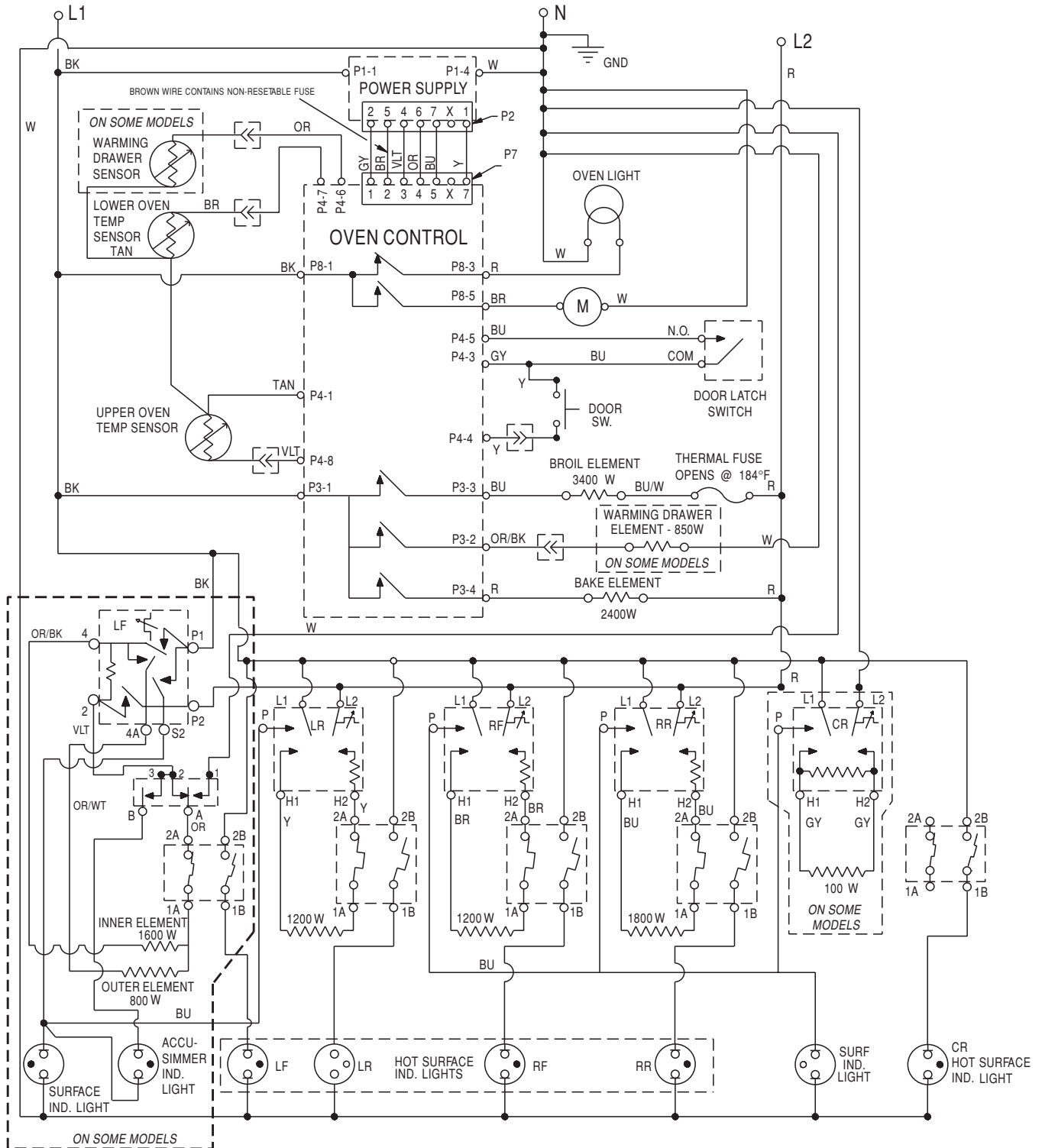

NOTE: SCHEMATIC SHOWS DOOR LATCH SWITCH IN THE "COOK" POSITION WITH THE OVEN DOOR OPEN, AND ELEMENTS OFF.

8522647, Rev. A

# STRIP CIRCUITS

## SURFACE UNIT (TYPICAL)

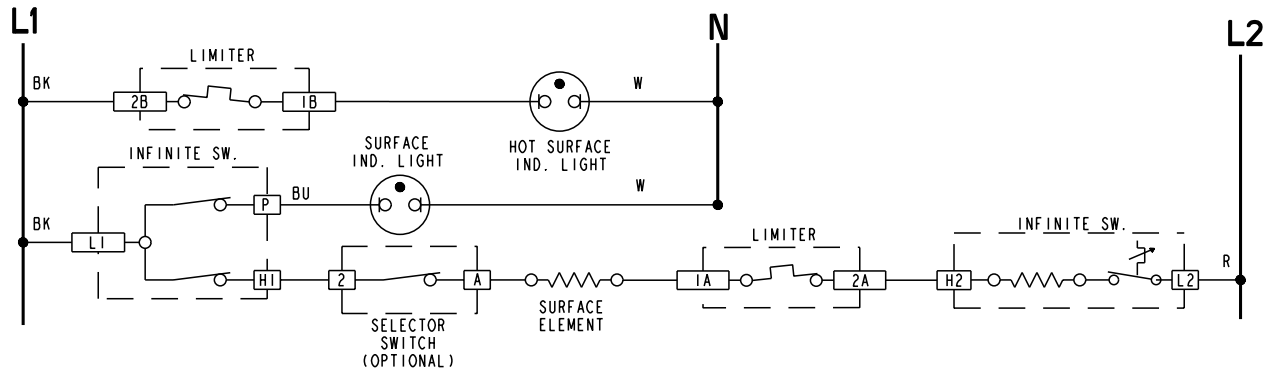

## SURFACE UNIT (ACCUSIMMER)

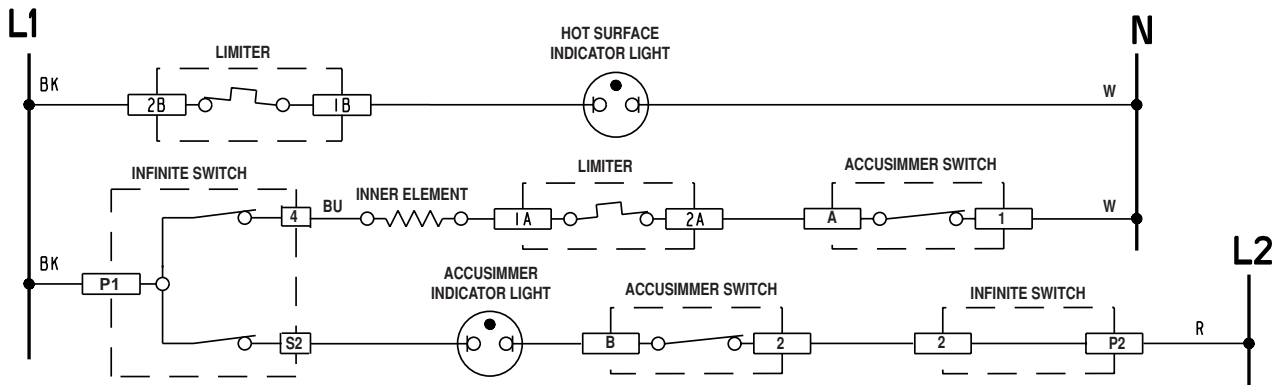

## SURFACE UNIT (DUAL)

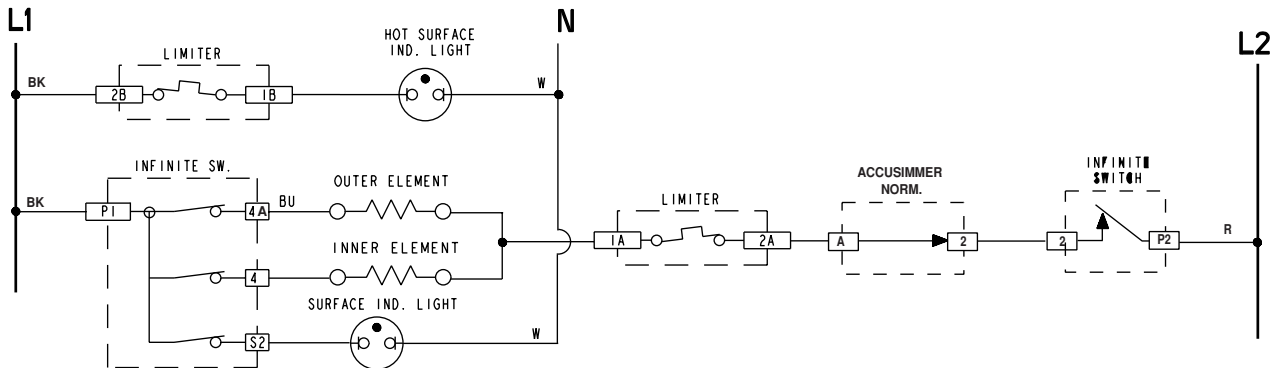



# BROIL

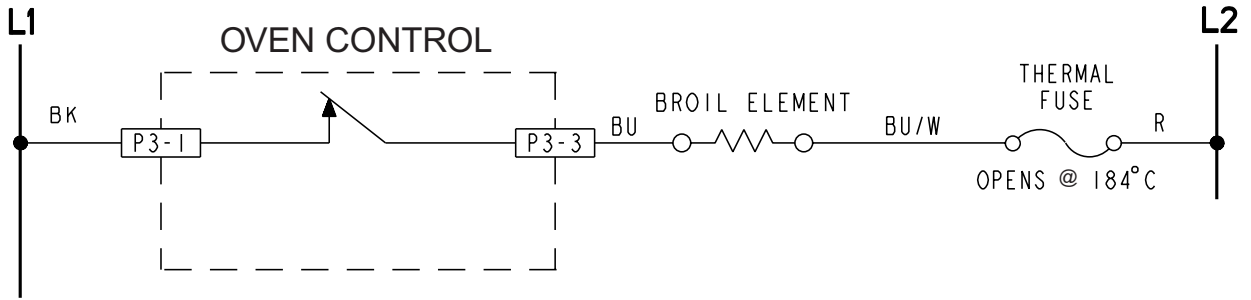

# BAKE

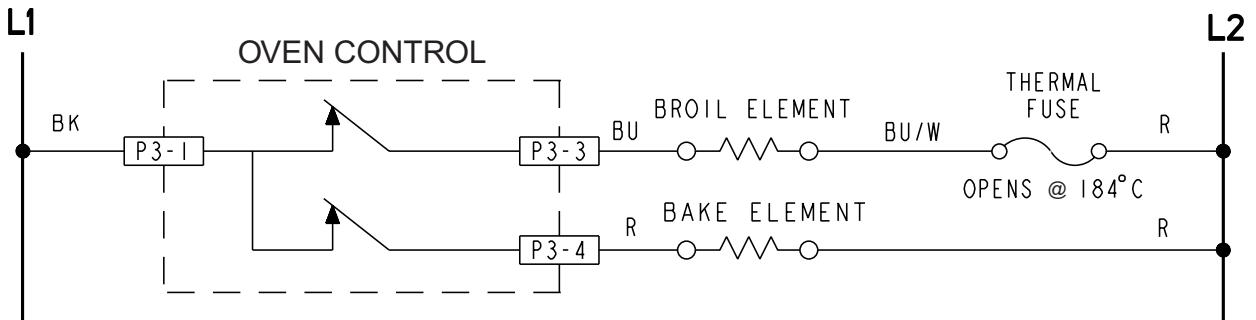

# CLEAN

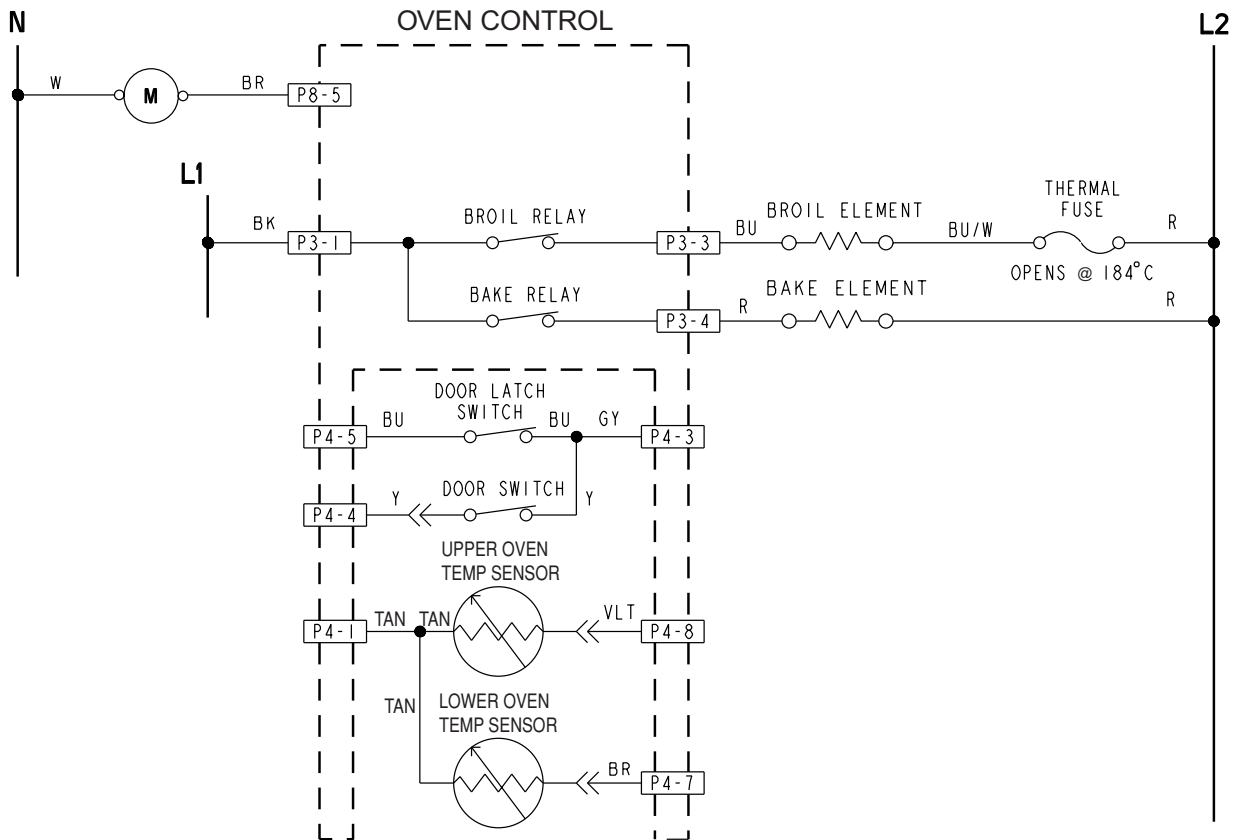

## CLOCK DISPLAY ON

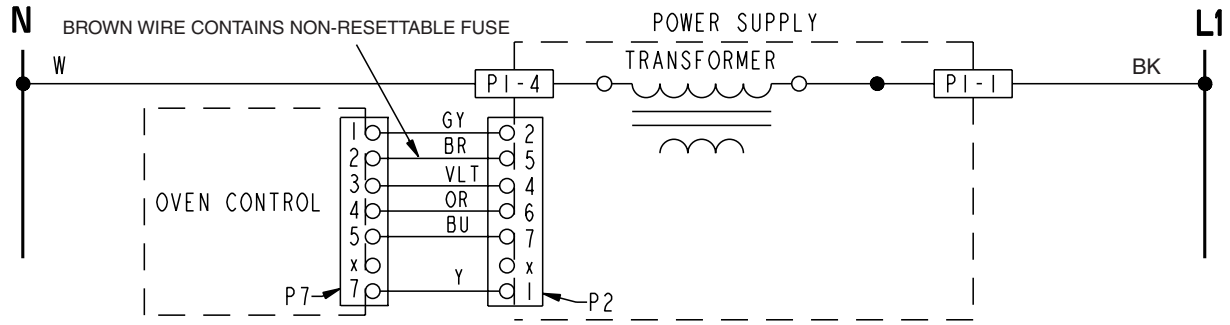

## OVEN LIGHT

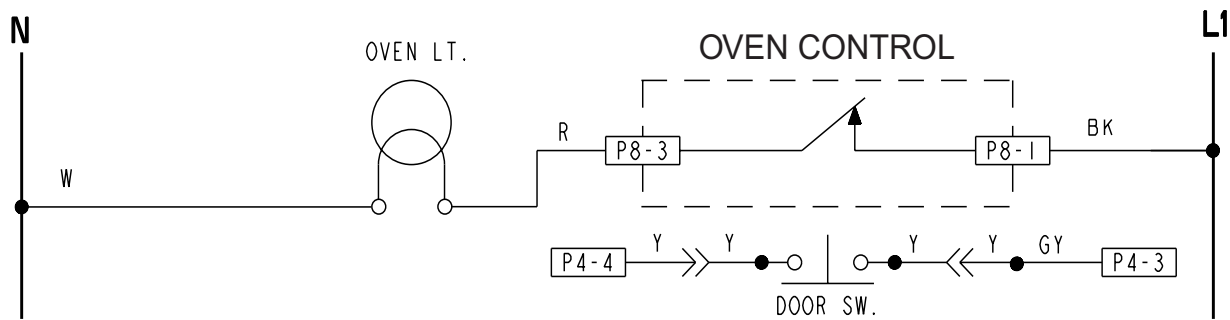

## QUICK-DISCONNECT PLUGS (FOR POWER SUPPLY)

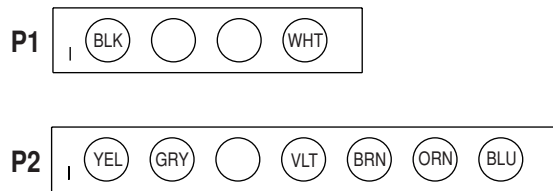

## QUICK-DISCONNECT PLUGS (FOR CONTROL)

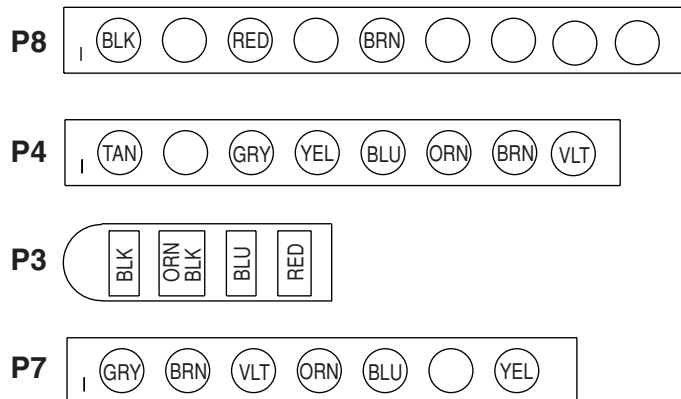

# TECH TIPS

## DUO COOKING SYSTEM FLOW CHART

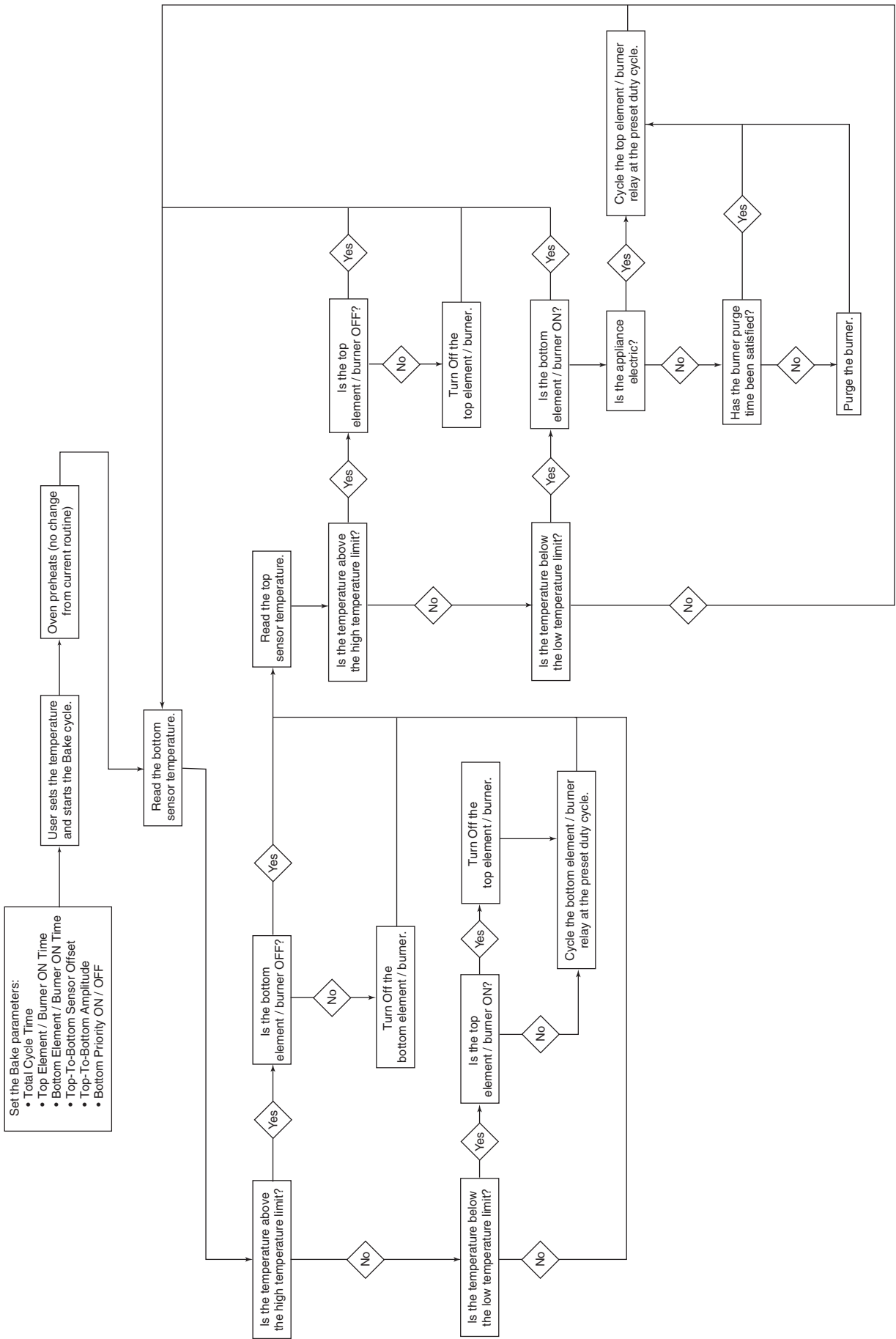

— NOTES —

— NOTES —

— NOTES —

# **PRODUCT SPECIFICATIONS AND WARRANTY INFORMATION SOURCES**

**IN THE UNITED STATES:**

**FOR PRODUCT SPECIFICATIONS AND WARRANTY INFORMATION CALL:**

FOR WHIRLPOOL PRODUCTS: 1-800-253-1301

FOR KITCHENAID PRODUCTS: 1-800-422-1230

FOR ROPER PRODUCTS: 1-800-447-6737

**FOR TECHNICAL ASSISTANCE WHILE AT THE CUSTOMER'S HOME CALL:**

THE TECHNICAL ASSISTANCE LINE: 1-800-253-2870

**HAVE YOUR STORE NUMBER READY TO IDENTIFY YOU AS AN  
AUTHORIZED SERVICER**

**FOR LITERATURE ORDERS:**

PHONE: 1-800-851-4605

---

**IN CANADA:**

**FOR PRODUCT SPECIFICATIONS AND WARRANTY INFORMATION CALL:**

1-800-461-5681

**FOR TECHNICAL ASSISTANCE WHILE AT THE CUSTOMER'S HOME CALL:**

THE TECHNICAL ASSISTANCE LINE: 1-800-488-4791

**HAVE YOUR STORE NUMBER READY TO IDENTIFY YOU AS AN  
AUTHORIZED SERVICER**

