



CONSUMER SERVICES TECHNICAL
EDUCATION GROUP PRESENTS

KR-30

ELECTRIC BUILT-IN DOUBLE OVEN



JOB AID
Part No. 8178007

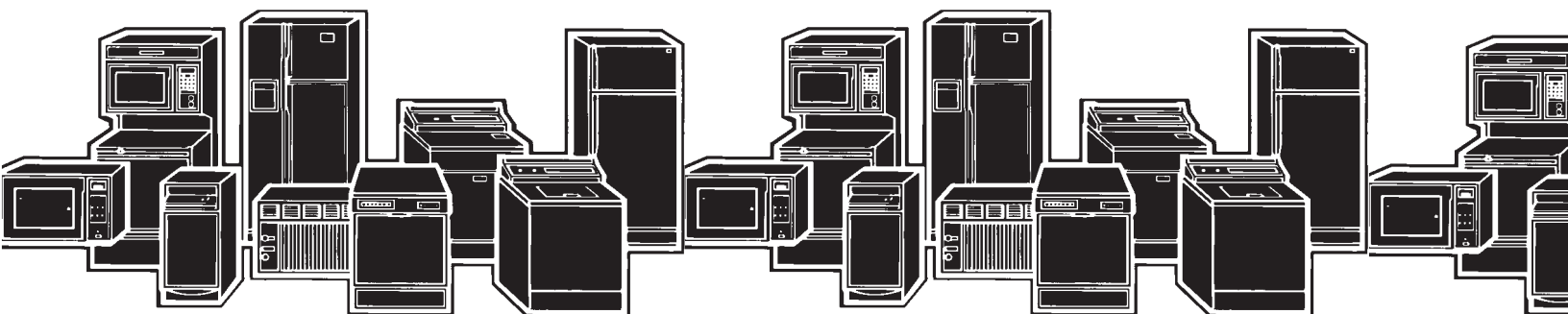

FORWARD

This Job Aid, "Whirlpool Electric Built-In Double Oven," (Part No. 8178007), provides the technician with information on the installation and service of the Whirlpool Electric Built-In Double Oven. It is to be used as a training Job Aid and Service Manual. For specific information on the model being serviced, refer to the "Use and Care Guide," or "Tech Sheet" provided with the Whirlpool Electric Built-In Double Oven.

The Wiring Diagrams and Strip Circuits used in this Job Aid are typical and should be used for training purposes only. Always use the Wiring Diagram supplied with the product when servicing the unit.

GOALS AND OBJECTIVES

The goal of this Job Aid is to provide detailed information that will enable the service technician to properly diagnose malfunctions and repair the Whirlpool Electric Built-In Double Oven.

The objectives of this Job Aid are to:

- Understand and follow proper safety precautions.
- Successfully troubleshoot and diagnose malfunctions.
- Successfully perform necessary repairs.
- Successfully return the Electric Built-In Double Oven to its proper operational status.

WHIRLPOOL CORPORATION assumes no responsibility for any repair made on our products by anyone other than Authorized Factory Service Technicians.

Copyright 2001, Whirlpool Corporation, Benton Harbor, MI 49022

Table of Contents

Page

SPECIFICATIONS	1-1
INSTALLATION HIGHLIGHTS	2-1
Electrical Supply Requirements	2-1
Removing & Reinstalling The Oven Door	2-3
PRODUCT OPERATION	3-1
Air Flow	3-1
The Oven Shutdown Thermal Fuse & Control Panel Thermal Fuse	3-2
The Oven Door Latch Assembly	3-3
How The Self-Clean Cycle Works	3-4
COMPONENT ACCESS	4-1
Component Locations	4-1
Removing The Thermal Fuse, The Oven Control/Display Boards, And The Touch Panel Assembly	4-2
Removing The Power Supply Wiring Terminal Block And The Upper & Lower Blower Motors	4-4
Removing The Upper & Lower Oven Door Latch Assembly	4-6
Removing An Oven Light & An Oven Temperature Sensor	4-8
Removing A Broil Element	4-9
Removing A Bake Element	4-10
Removing An Oven Shutdown Thermal Fuse	4-11
Removing The Convection Fan Motor Assembly	4-12
Removing The Oven Door Glass, Hinges, & Handle	4-14
Removing The Oven Door Gasket	4-16
COMPONENT TESTING	5-1
Blower Motors	5-1
Oven Temperature Sensor	5-1
Convection Fan Motor	5-2
Oven Shutdown Thermal Fuse	5-2
Broil Element	5-3
Bake Element	5-3
Oven Door Latch Assembly	5-4
Control Panel Thermal Fuse	5-4
DIAGNOSIS & TROUBLESHOOTING	6-1
Diagnostics	6-1
Fahrenheit To Celsius Conversion	6-1
Programming The Cavity Size	6-1
Electrostatic Discharge Sensitive Electronics	6-1
Failure/Error Display Codes—Tech Sheets 4451887C & 4451888A	6-2
Failure/Error Display Codes—Tech Sheet 4452022A	6-3
Relay Logic Chart—Tech Sheets 4451887C & 4451888A	6-4
Relay Logic Chart—Tech Sheet 4452022A	6-4
Control Panel Test Locations—Tech Sheets 4451887C & 4451888A	6-5
Control Panel Test Locations—Tech Sheet 4452022A	6-6

	Page
WIRING DIAGRAMS & STRIP CIRCUITS	7-1
Schematic Diagram 1 (Tech Sheet 4451887C)	7-1
Strip Circuits	7-2
Schematic Diagram 2 (Tech Sheet 4451888A)	7-4
Strip Circuits	7-5
Schematic Diagram 3 (Tech Sheet 4452022A)	7-7
Strip Circuits	7-8
Tech Sheet / Model Number Usage Charts	7-10
TECH TIPS	8-1

WHIRLPOOL MODEL & SERIAL NUMBER DESIGNATIONS

MODEL NUMBER

MODEL NUMBER		G	B	D	27	7	P	D	S	0
INTERNATIONAL SALES IND. OR MARKETING CHANNEL IF PRESENT										
PRODUCT GROUP G = WHIRLPOOL GOLD R = ELECTRIC S = GAS										
PRODUCT IDENTIFICATION B = BUILT-IN M = BUILT-IN MICROWAVE COMBO S = BUILT-IN HIGH-SPEED COMBO										
CONFIGURATION S = SINGLE D = DOUBLE C = COMBO										
OVEN SIZE 24 = 24" 27 = 27" 30 = 30"										
FEATURE VARIATIONS 0 = STANDARD 2 = CONTINUOUS CLEAN 3 = EASY CLEAN 5 = S/C SINGLE & S/C STD DOUBLE & MWC-S/C COMBO 6 = S/C-S/C DOUBLE & CRISP S/C COMBO 7 = CONVECTION SINGLE, S/C-CONV. DOUBLE & CRISP CONV. COMBO 8 = CONV.-CONV. DOUBLE & CONV.-CONV. COMBO 9 = MULTIMODE										
DOOR TYPE B = SOLID BLACK GLASS P = PANORAMIC WINDOW GLASS										
YEAR OF INTRODUCTION D = 1995, G = 1998, H = 1999, J = 2000, K = 2001										
COLOR CODE B = BLACK, Z = ALMOND, Q = WHITE, S = STAINLESS, T = BISCUIT										
ENGINEERING CHANGE (0, 1, 2, ETC.)										

SERIAL NUMBER

SERIAL NUMBER	X	K	41	01002
MANUFACTURING SITE X = OXFORD				
YEAR OF PRODUCTION K = 2000, L = 2001, M = 2002				
WEEK OF PRODUCTION 41st WEEK				
PRODUCT SEQUENCE NUMBER				

MODEL & SERIAL NUMBER LABEL AND TECH SHEET LOCATIONS

The Model/Serial Number label and Tech Sheet locations are shown below.

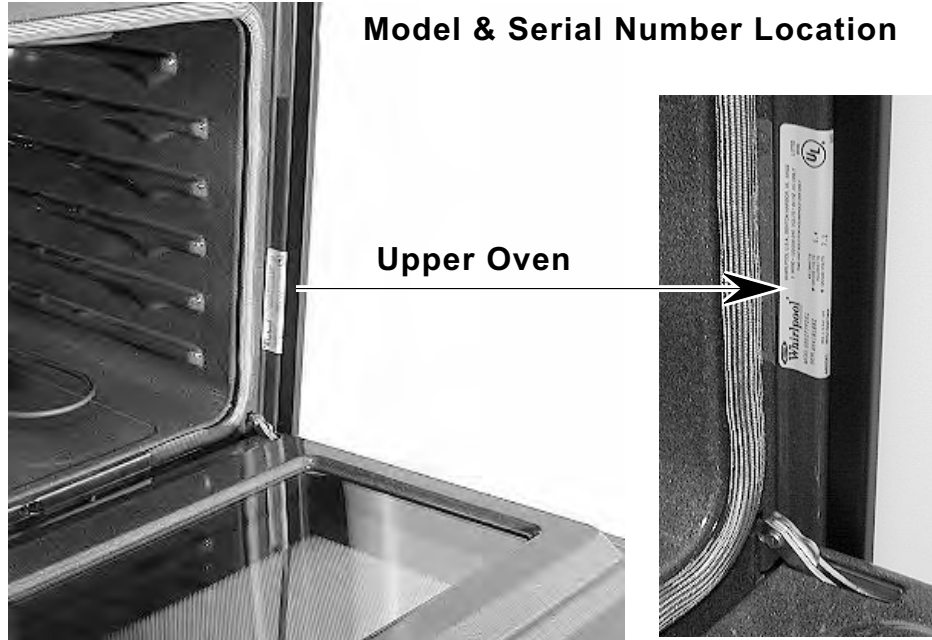

Tech Sheet Location (Below Top Front Cover)

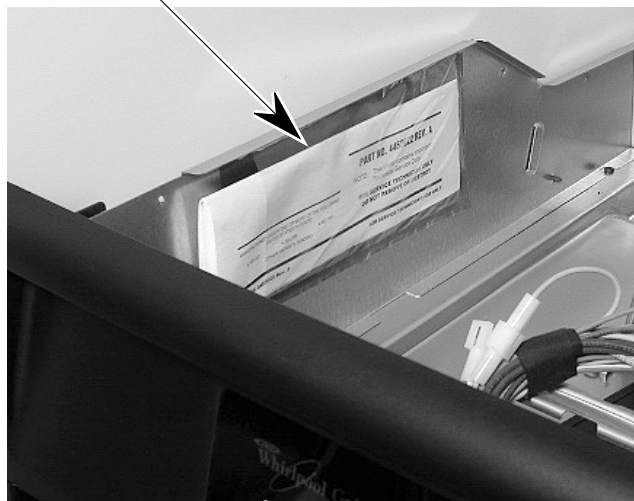

IMPORTANT SAFETY INFORMATION

Your safety and the safety of others is very important.

Important safety messages have been provided in this Job Aid. Always read and obey all safety messages.



This is the safety alert symbol.

This symbol alerts you to hazards that can kill or hurt you and others.

All safety messages will be preceded by the safety alert symbol and the word **“WARNING.”**

All safety messages will identify the hazard, tell you how to reduce the chance of injury, and tell you what can happen if the instructions are not followed.

IMPORTANT

Electrostatic Discharge (ESD) Sensitive Electronics

ESD problems are present everywhere. ESD may damage or weaken the electronic control assembly. The new control assembly may appear to work well after repair is finished, but failure may occur at a later date due to ESD stress.

- Use an anti-static wrist strap. Connect the wrist strap to the green ground connection point, or to an unpainted metal surface in the appliance.

- OR -

Touch your finger repeatedly to a green ground connection point, or to an unpainted metal surface in the appliance.

- Before removing the part from its package, touch the anti-static bag to a green ground connection point, or to an unpainted metal surface in the appliance.
- Avoid touching electronic parts, or terminal contacts. Handle the electronic control assembly by the edges only.
- When repackaging the failed electronic control assembly in an anti-static bag, observe the previous instructions.

— NOTES —

SPECIFICATIONS

Model Number	GBD307PD	GBD277PD	RBD245PD
Model Description	Double Built-In Oven	Double Built-In Oven	Double Built-In Oven
Size-Configuration	30"	27"	24"
Color Available	Biscuit, Stainless	Stainless	Biscuit, White-On-White, Black
Dimensions/Specifications			
Exterior Dimensions			
Overall Height (in)	51 1/8"	51 1/8"	51 1/8"
Overall Width (in)	29 3/4"	26 3/4"	23 3/4"
Overall Depth Inc Hrdwr/Hndl (in)	25 1/8"	25 1/8"	25 1/8"
Depth W/O Handle (in)	23 7/8"	23 7/8"	23 7/8"
Cutout Dimensions			
Cutout Height (in) (Measure Or Min/Max)	49 3/4"	49 3/4"	49 3/4"
Cutout Width (in) (Measure Or Min/Max)	28 1/2"	25 1/2"	22 1/2"
Cutout Depth (in) (Measure Or Min/Max)	23 1/4"	23 1/4"	23 1/4"
Total Connected Load (In KW)			
240 Volts	7.2	7.2	9.7
208 Volts	5.4	5.4	7.3
Circuit Amps	40	40	40
Oven Control Type	Electronic	Electronic	Electronic
Interior			
Main/Single Oven			
Main Cleaning System	Self Cleaning	Self Cleaning	Self Cleaning
Main Self Clean Latch	Yes	Yes	Yes
Main Oven Liner Finish	Porcelain	Porcelain	Porcelain
Main Oven Height (in)	16"	16"	16"
Main Oven Width (in)	25"	22"	19"
Main Oven Depth (in)	18 1/2"	18 1/2"	18 1/2"
Electric Element Output			
Bake (W@240/208V)	2000 W/ 1500 W	2000 W/ 1500 W	2000 W/ 1500 W
Broil (W@240/208V)	3000 W/ 2250 W	3000 W/ 2250 W	3000 W/ 2250 W
Lower/Secondary Oven			
Lower/Secondary Cleaning System	Self Cleaning	Self Cleaning	Standard
Lower/Secondary Auto Self Clean Latch	Yes	Yes	No
Lower/Secondary Oven Height (in)	16"	16"	16"
Lower/Secondary Oven Width (in)	25"	22"	19"
Lower/Secondary Oven Depth (in)	18 1/2"	18 1/2"	18 1/2"
Lower/Secondary Electric Element Output			
Lower/Secondary Bake (w@240/208v)	2000 W/ 1500 W	2000 W/ 1500 W	2000 W/ 1500 W
Lower/Secondary Broil (w@240/208v)	3000 W/ 2250 W	3000 W/ 2250 W	3000 W/ 2250 W
Miscellaneous			
Product Literature			
Cookbook Part/Comment	4449237	4449237	N/A
Installation Instructions Part/Comment	4450411	4450410	4448969
Service Manual Part/Comment	8178007	8178007	8178007
Tech Sheet Part/Comment	4451887	4451887	4451887
Use & Care Guide Oven Part/Comment	4450569	4450569	4448976
Other			
Agency Approvals	UL	UL	UL, CSA
Residential Use Only	Yes	Yes	Yes
Warranty			
Full (Months)	12	12	12

Model Number	RBD275PD	RBD276PD	RBD277PD
Model Description	Double Built-In Oven	Double Built-In Oven	Double Built-In Oven
Size-Configuration	27"	27"	27"
Color Available	Biscuit, White-On-White, Black	Black, White-On -White	Black, White-On -White
Dimensions/Specifications			
Exterior Dimensions			
Overall Height (in)	51 1/8"	51 1/8"	51 1/8"
Overall Width (in)	26 3/4"	26 3/4"	26 3/4"
Overall Depth Inc Hrdwr/Hndl (in)	25 1/8"	25 1/8"	25 1/8"
Depth W/O Handle (in)	23 7/8"	23 7/8"	23 7/8"
Cutout Dimensions			
Cutout Height (in) (Measure Or Min/Max)	49 3/4"	49 3/4"	49 3/4"
Cutout Width (in) (Measure Or Min/Max)	25 1/2"	25 1/2"	25 1/2"
Cutout Depth (in) (Measure Or Min/Max)	23 1/4"	23 1/4"	23 1/4"
Total Connected Load (In KW)			
240 Volts	9.7	9.7	9.7
208 Volts	7.3	7.3	7.3
Circuit Amps	40	40	40
Oven Control Type	Electronic	Electronic	Electronic
Interior			
Main/Single Oven			
Main Cleaning System	Self Cleaning	Self Cleaning	Self Cleaning
Main Self Clean Latch	Yes	Yes	Yes
Main Oven Liner Finish	Porcelain	Porcelain	Porcelain
Main Oven Height (in)	16"	16"	16"
Main Oven Width (in)	22"	22"	22"
Main Oven Depth (in)	18 1/2"	18 1/2"	18 1/2"
Electric Element Output			
Bake (W@240/208V)	2000 W/ 1500 W	2000 W/ 1500 W	2000 W/ 1500 W
Broil (W@240/208V)	3000 W/ 2250 W	3000 W/ 2250 W	3000 W/ 2250 W
Lower/Secondary Oven			
Lower/Secondary Cleaning System	Standard	Self Cleaning	Self Cleaning
Lower/Secondary Auto Self Clean Latch	No	Yes	Yes
Lower/Secondary Oven Height (in)	16"	16"	16"
Lower/Secondary Oven Width (in)	19"	19"	22"
Lower/Secondary Oven Depth (in)	18 1/2"	18 1/2"	18 1/2"
Lower/Secondary Electric Element Output			
Lower/Secondary Bake (w@240/208v)	2000 W/ 1500 W	2000 W/ 1500 W	2000 W/ 1500 W
Lower/Secondary Broil (w@240/208v)	3000 W/ 2250 W	3000 W/ 2250 W	3000 W/ 2250 W
Miscellaneous			
Product Literature			
Cookbook Part/Comment	N/A	N/A	N/A
Installation Instructions Part/Comment	4448970	4448970	4448969
Service Manual Part/Comment	8178007	8178007	8178007
Tech Sheet Part/Comment	4451887	4451887	4451887
Use & Care Guide Oven Part/Comment	4448976	4448976	4448976
Other			
Agency Approvals	UL, CSA	UL, CSA	UL, CSA
Residential Use Only	Yes	Yes	Yes
Warranty			
Full (Months)	12	12	12

Model Number	RBD305PD	RBD306PD	RBD307PD
Model Description	Double Built-In Oven	Double Built-In Oven	Double Built-In Oven
Size-Configuration	30"	30"	30"
Color Available	Biscuit, White-On-White, Black	Black, Almond-On-Almond, White-On-White	Black, Almond-On-Almond, White-On-White
Dimensions/Specifications			
Exterior Dimensions			
Overall Height (in)	51 1/8"	51 1/8"	51 1/8"
Overall Width (in)	29 3/4"	29 3/4"	29 3/4"
Overall Depth Inc Hrdwr/Hndl (in)	25 1/8"	25 1/8"	25 1/8"
Depth W/O Handle (in)	23 7/8"	23 7/8"	23 7/8"
Cutout Dimensions			
Cutout Height (in) (Measure Or Min/Max)	49 3/4"	49 3/4"	49 3/4"
Cutout Width (in) (Measure Or Min/Max)	28 1/2"	28 1/2"	28 1/2"
Cutout Depth (in) (Measure Or Min/Max)	23 1/4"	23 1/4"	23 1/4"
Total Connected Load (In KW)			
240 Volts	9.7	9.7	9.7
208 Volts	7.3	7.3	7.3
Circuit Amps	40	40	40
Oven Control Type	Electronic	Electronic	Electronic
Interior			
Main/Single Oven			
Main Cleaning System	Self Cleaning	Self Cleaning	Self Cleaning
Main Self Clean Latch	Yes	Yes	Yes
Main Oven Liner Finish	Porcelain	Porcelain	Porcelain
Main Oven Height (in)	16"	16"	16"
Main Oven Width (in)	25"	25"	25"
Main Oven Depth (in)	18 1/2"	18 1/2"	18 1/2"
Electric Element Output			
Bake (W@240/208V)	2000 W/ 1500 W	2000 W/ 1500 W	2000 W/ 1500 W
Broil (W@240/208V)	3000 W/ 2250 W	3000 W/ 2250 W	3000 W/ 2250 W
Lower/Secondary Oven			
Lower/Secondary Cleaning System	Standard	Standard	Self Cleaning
Lower/Secondary Auto Self Clean Latch	No	No	Yes
Lower/Secondary Oven Height (in)	16"	16"	16"
Lower/Secondary Oven Width (in)	25"	25"	25"
Lower/Secondary Oven Depth (in)	18 1/2"	18 1/2"	18 1/2"
Lower/Secondary Electric Element Output			
Lower/Secondary Bake (w@240/208v)	2000 W/ 1500 W	2000 W/ 1500 W	2000 W/ 1500 W
Lower/Secondary Broil (w@240/208v)	3000 W/ 2250 W	3000 W/ 2250 W	3000 W/ 2250 W
Miscellaneous			
Product Literature			
Cookbook Part/Comment	4449066	4449066	4449066
Installation Instructions Part/Comment	4448975	4448975	4448975
Service Manual Part/Comment	8178007	8178007	8178007
Tech Sheet Part/Comment	4451887	4451887	4451887
Use & Care Guide Oven Part/Comment	4448976	4448976	4448976
Other			
Agency Approvals	UL, CSA	UL, CSA	UL, CSA
Residential Use Only	Yes	Yes	Yes
Warranty			
Full (Months)	12	12	12

— NOTES —

INSTALLATION HIGHLIGHTS

ELECTRICAL SUPPLY REQUIREMENTS

WARNING

Electrical Shock Hazard

- An electrical ground is required on this appliance.
- Do not use an extension cord with this appliance.
- If a cold water pipe is interrupted by plastic, nonmetallic gaskets, or other insulating materials, do not use for grounding.
- Do not ground to a gas pipe.
- Do not use a fuse in the neutral or grounding circuit. It could result in an electrical shock.
- Check with a qualified electrician if you are in doubt as to whether the appliance is properly grounded.

Failure to follow these instructions could result in death or serious injury.

GENERAL

If codes permit, and a separate grounding wire is used, it is recommended that a qualified electrician determine that the grounding path and wire gauge are in accordance with local codes.

The following information applies to the built-in electric wall oven wiring:

- The oven must be connected to the proper electrical voltage and frequency as specified on the model/serial rating plate (located on the upper oven frame).
- Models rated from 7.3 to 9.6 kW at 240-volts, (5.5 to 7.2 kW at 208-volts), require a separate 40-ampere circuit. Models rated at 7.2 kW and below at 240-volts, (5.4 kW and below at 208-volts), require a separate 30-ampere circuit.

- The oven must be connected with copper wire only.
- Wire sizes and connections must conform to the requirements of the National Electrical Code, ANSI/NFPA 70—latest edition*, and all local codes and ordinances. Wire sizes and connections must conform with the rating of the appliance. Copies of the standards listed above may be obtained from:

*** National Fire Protection Association
Batterymarch Park
Quincy, Massachusetts 02269**

- The oven should be connected directly to a time delay fuse or circuit breaker through flexible, armored, or nonmetallic sheathed, copper cable. The flexible, armored cable that extends from the appliance should be connected directly to the junction box.
- Fuse both sides of the line.
- Locate the junction box to allow as much slack as possible between the junction box and the appliance so that the appliance can be moved if servicing is ever necessary. Do not cut the conduit.
- A U.L.-listed conduit connector must be provided at the junction box.
- Wiring diagrams are located in Section 7 of this Job Aid.
- A Tech Sheet is located below the top access cover on all models.

ELECTRICAL WIRING

! WARNING

Electrical Shock Hazard

- An electrical ground is required on this appliance.
- Do not connect to the electrical supply until the appliance is permanently grounded.
- Turn off power to the junction box before making the electrical connections.
- Connect the appliance to a grounded, metallic, permanent wiring system.

Failure to follow these instructions could result in death or serious injury.

1. Insert the end of the flexible conduit through the cabinet opening to the junction box inlet.
2. Disconnect the power going to the junction box.
3. Open the junction box cover and connect the flexible conduit to the U.L.-listed conduit connector.
4. Connect the ends of the black wires together with twist-on connectors (see the illustration below).
5. Connect the ends of the red wires together with twist-on connectors.

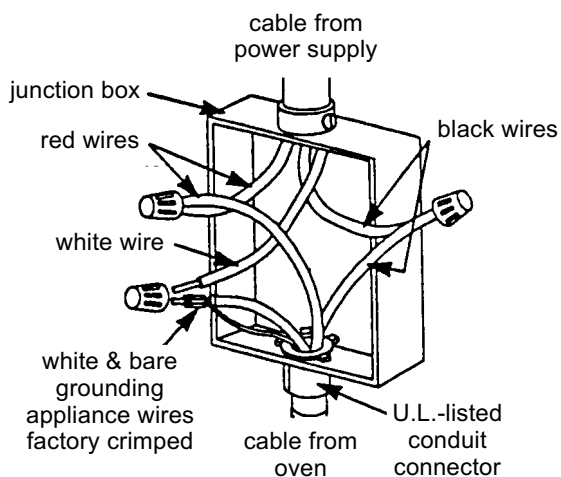

Crimped Grounding Conductors To White (Neutral) Wire

If local codes DO permit connecting the cabinet-grounding conductor to a neutral junction box wire, perform steps 6 and 7.

If local codes DO NOT permit connecting the cabinet-grounding conductor to a neutral junction box wire, or if you are connecting the appliance to a 4-wire electrical system, perform steps 8 through 11.

6. Connect the factory-crimped bare and white electrical wires coming from the appliance conduit cable to the white (neutral) wire inside the junction box (see the illustration below).
7. Replace the junction box cover.
8. Separate the factory-crimped bare and white electrical wires coming from the appliance conduit cable.
9. Connect the white appliance wire to the white (neutral) wire inside the junction box.
10. Connect the bare grounding wire from the appliance to a grounded wire inside the junction box. **IMPORTANT: Do not connect the bare grounding wire to the white (neutral) wire in the junction box.**
11. Replace the junction box cover.

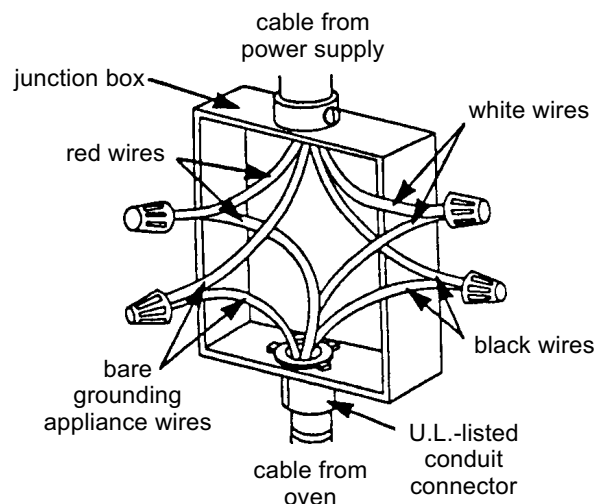

Separate Grounding Conductors To White (Neutral) & Bare Wires

REMOVING & REINSTALLING THE OVEN DOOR

! WARNING

Personal Injury Hazard

- Use both hands to remove oven doors.
- Do not use the handle or any portion of the front frame or trim for lifting.
- Because of the weight and size of the oven, two or more people are required to move and safely install it.

Failure to properly grasp the oven doors or to lift the oven properly could result in personal injury or damage to the product.

CAUTION: Do not remove the shipping base or the shipping feet at the front lower corners of the oven. The shipping feet will protect the lower oven trim until the oven is inserted into the cabinet cutout.

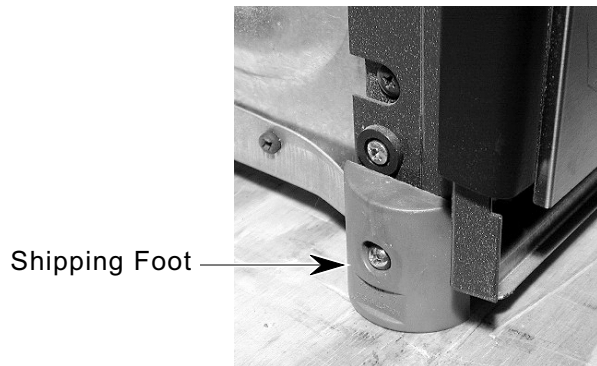

To remove the oven door:

1. Install a pin in the hole of each oven door hinge hanger.

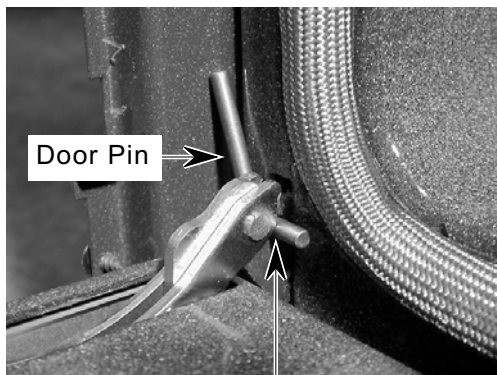

Door Pin Into Hinge Hanger Hole

2. Close the oven door as far as the two pins will allow.
3. Grasp the sides of the door and lift the door until it stops, then pull the hinge hangers out of the slots.

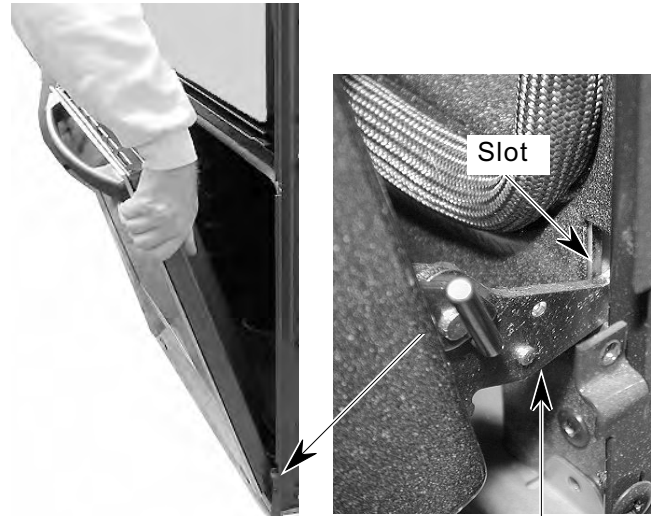

Hinge Hanger

To reinstall the oven door:

1. Grasp the sides of the door and tilt it back at a slight angle, then insert the hinge hangers into the hinge slots as far as they will go.
2. Rotate the top of the door towards the oven so the hinge hangers fit onto the support pins.
3. Close the oven door as far as the pins will allow, and make sure that the hinge hangers are fully seated on the support pins. If they are not seated properly, the door will not close tightly and may be off-center. To seat the hinge hangers, open the door slightly, and push in on the bottom until the hangers are fully seated.
4. Open the oven door to its fully open position and remove the two hinge hanger pins.
5. Close the oven door completely and check it for proper operation and alignment.

— NOTES —

PRODUCT OPERATION

AIR FLOW

Intake air is drawn into the oven at two locations: through the control panel vent, (over the latch assembly and the inner chassis top), and through the side mounting rails (over the oven sides and around the back). Air also enters the oven at the back through the openings on the upper section of the rear cover. At this point, the air from the sides and the top mix. The air is then pulled through the blower, down the back of the unit between the outer and inner rear covers, and out the front of the unit via the bottom vent trim.

Air from the blower is forced over the cavity vent. The pressure differential causes air to be drawn from the cavity, where the air exits through a small opening on the left side of the control panel vent.

Air passes through the oven door by a combination of natural and forced convection. Air enters the door through the bottom slots, and passes between the outer glass, and the angled inner glass. This air exits through the top slots in the door via natural convection. Air also enters the bottom of the door, and is drawn between the two pieces of inner door glass, where it exits through the top slots in the upper part of the door. This air is then drawn into the blower, and is forced down the back of the unit between the inner and outer chassis covers, and finally out the bottom vent.

The purpose of the convection fan is to circulate hot air inside the oven cavity, not to evacuate the air. Thus, the air flow for the convection models and the non-convection models, is the same.

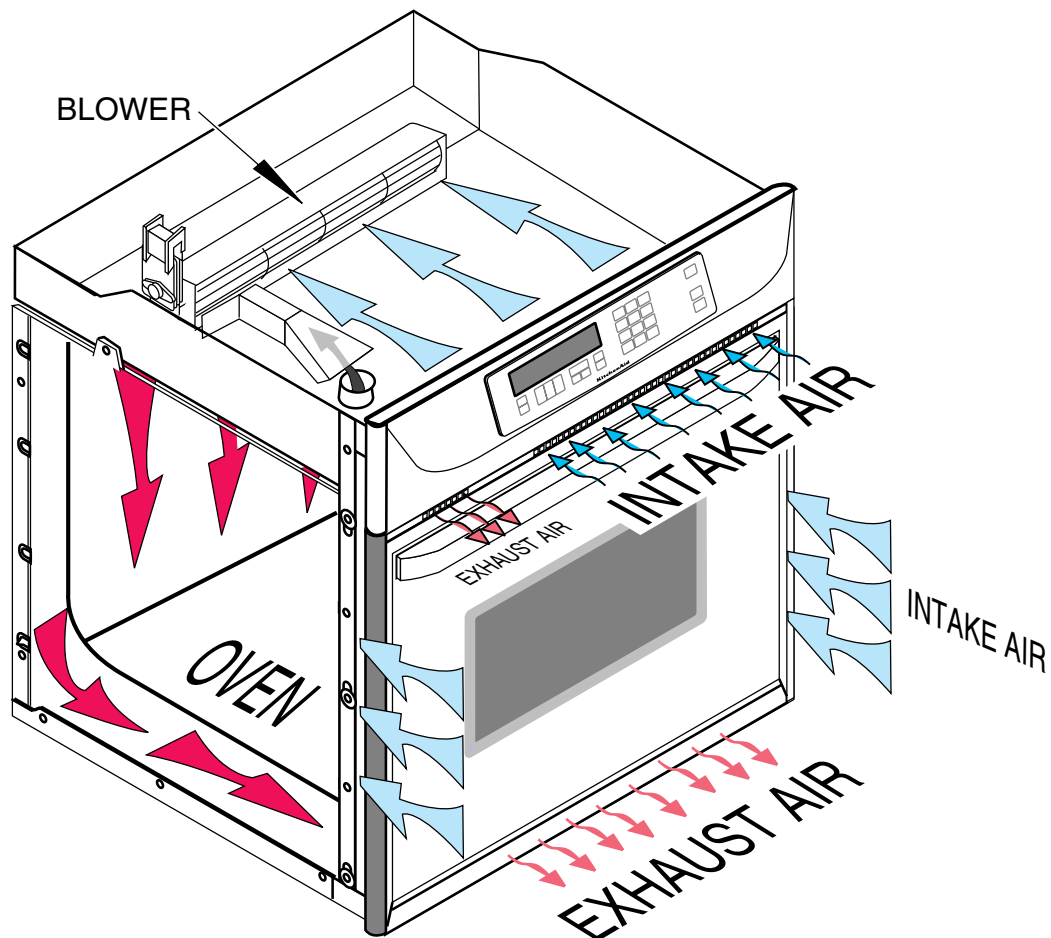

THE OVEN SHUTDOWN THERMAL FUSE & CONTROL PANEL THERMAL FUSE

There are two thermal fuses on the oven. The thermal fuses operate as follows:

- **Upper & Lower Oven Shutdown Thermal Fuse** — These thermal fuses are located on the rear of the oven at the indicated locations. Each oven shutdown thermal fuse opens L2 to the oven if the temperature at the rear panel exceeds 160°C/320°F. The two fuses are one-time, non-resettable safety devices.

- **Control Panel Thermal Fuse** — Protects the control panel area if the temperature exceeds 101°C/214°F. If the fuse opens, it shuts down the entire unit (no clock, etc.). One end of the thermal fuse is connected to the control panel at lug P7-1, and the other end is connected to the main wire harness. The thermal fuse is a one-time, non-resettable fuse.

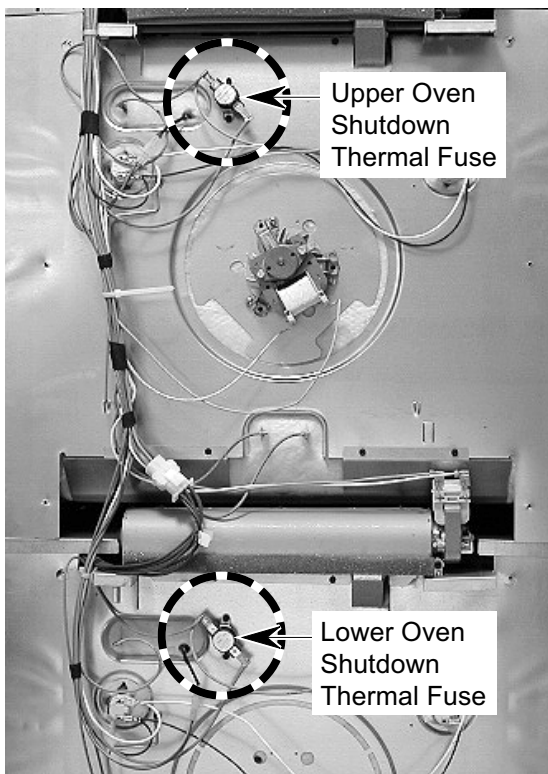

BACK OF OVEN

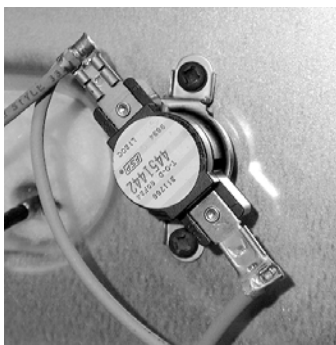

Oven Shutdown Thermal Fuse

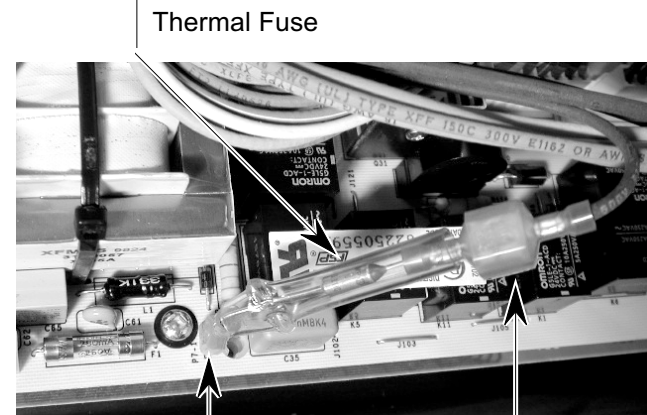
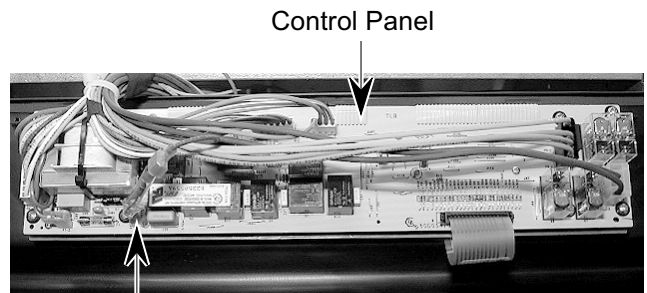

Connector P7-1

Connector To Wire Harness

THE OVEN DOOR LATCH ASSEMBLY

The door latch solenoid operates on a 120-volt dc pulse from the electronic control board. When the solenoid plunger is retracted, the oven door is in the “unlocked” position. When the solenoid plunger is extended, the oven door is in the “locked” position. When the door lock switch is open, the control senses that the door is “unlocked.” When the door lock switch closes, the control senses that the door is locked. The door lock switch, mounted on the solenoid bracket, is in the N.O. (normally-open) position.

During the self-clean cycle, the control board sends a 120-volt dc pulse to the solenoid windings, which extends the plunger (pushes it out), and moves the latch arm to lock the oven door. The movement of the arm also actuates the door lock switch arm, and closes it. When the self-clean cycle is over, the control board sends a 120-volt dc pulse to the solenoid, the plunger is retracted (pulled in), the latch arm releases the door, and the door lock switch opens.

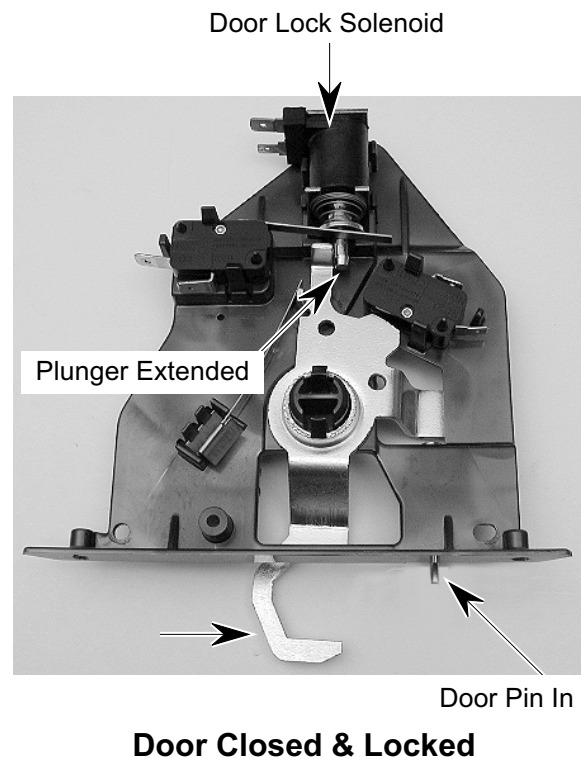
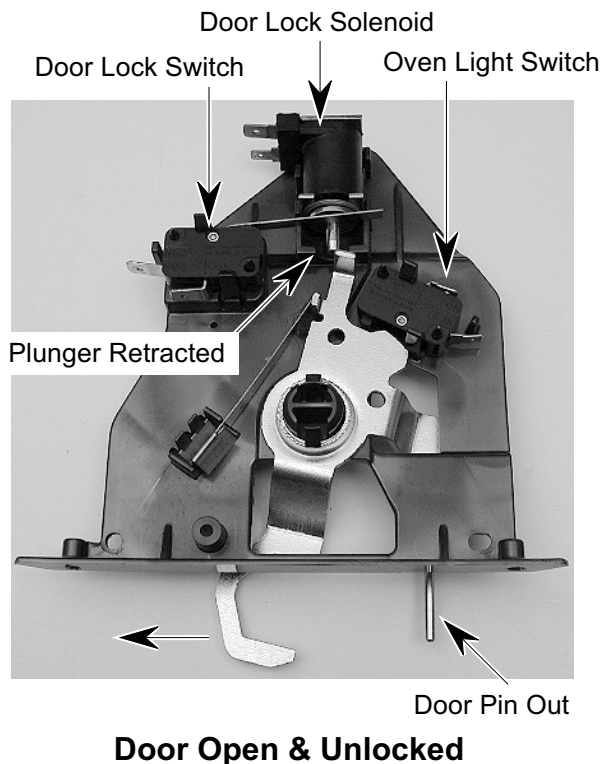

HOW THE SELF-CLEAN CYCLE WORKS

The Self-Clean cycle uses high heat to burn away soil and grease from inside the oven. During this cycle, the oven will get much hotter than it does under normal baking and broiling conditions (see the following chart).

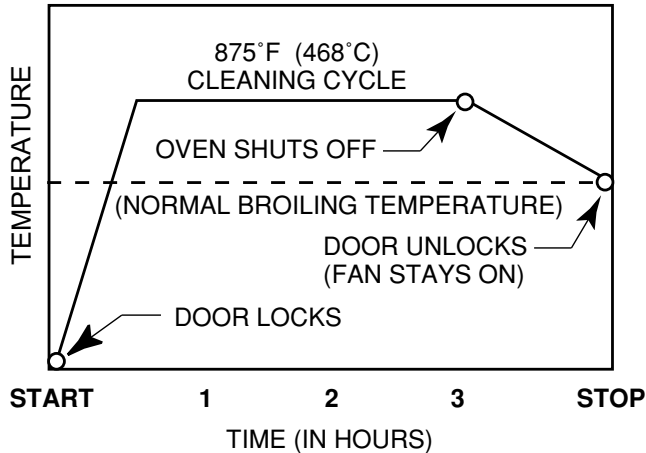

The oven is preset for a 3-1/2 hour Self-Clean cycle. However, you can adjust this cycle time to between 2-1/2 and 4-1/2 hours. The chart shows a normal 3-1/2 hour Self-Clean cycle. Note that although the heating turns off after 3-hours, the door will remain locked for an additional 1/2 hour so the oven can cool sufficiently.

If the latch switch is not satisfied during the clean operation, the cycle is terminated, and the display will show "close door" on convection models. On non-convection models, "door" will be displayed (see the strip circuit below).

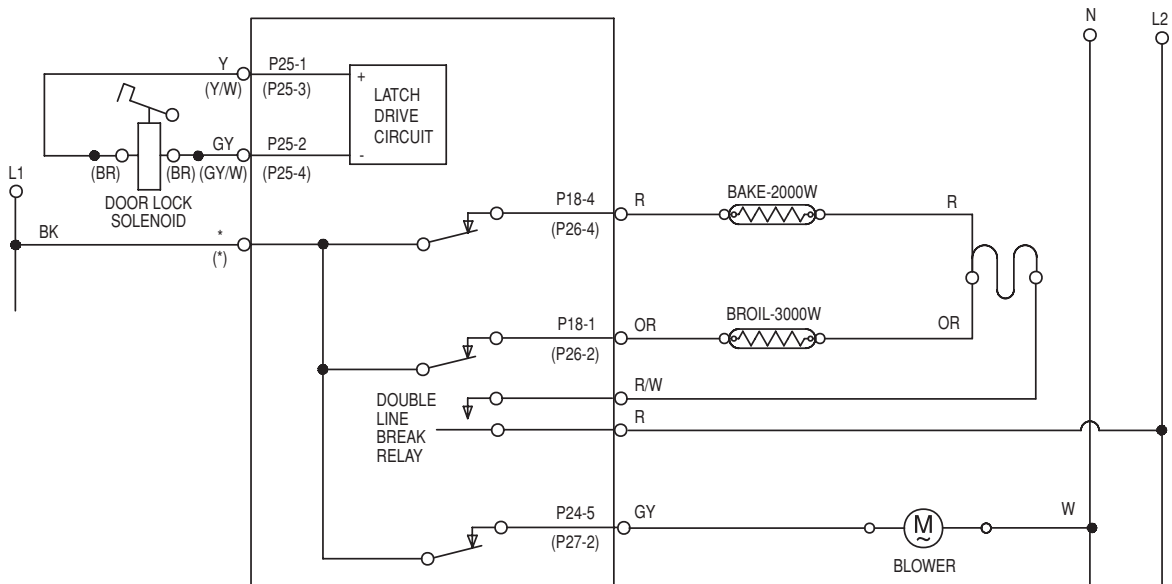

COMPONENT ACCESS

This section instructs you on how to service each component inside the Electric Built-In Double Oven . The components and their locations are shown below.

COMPONENT LOCATIONS

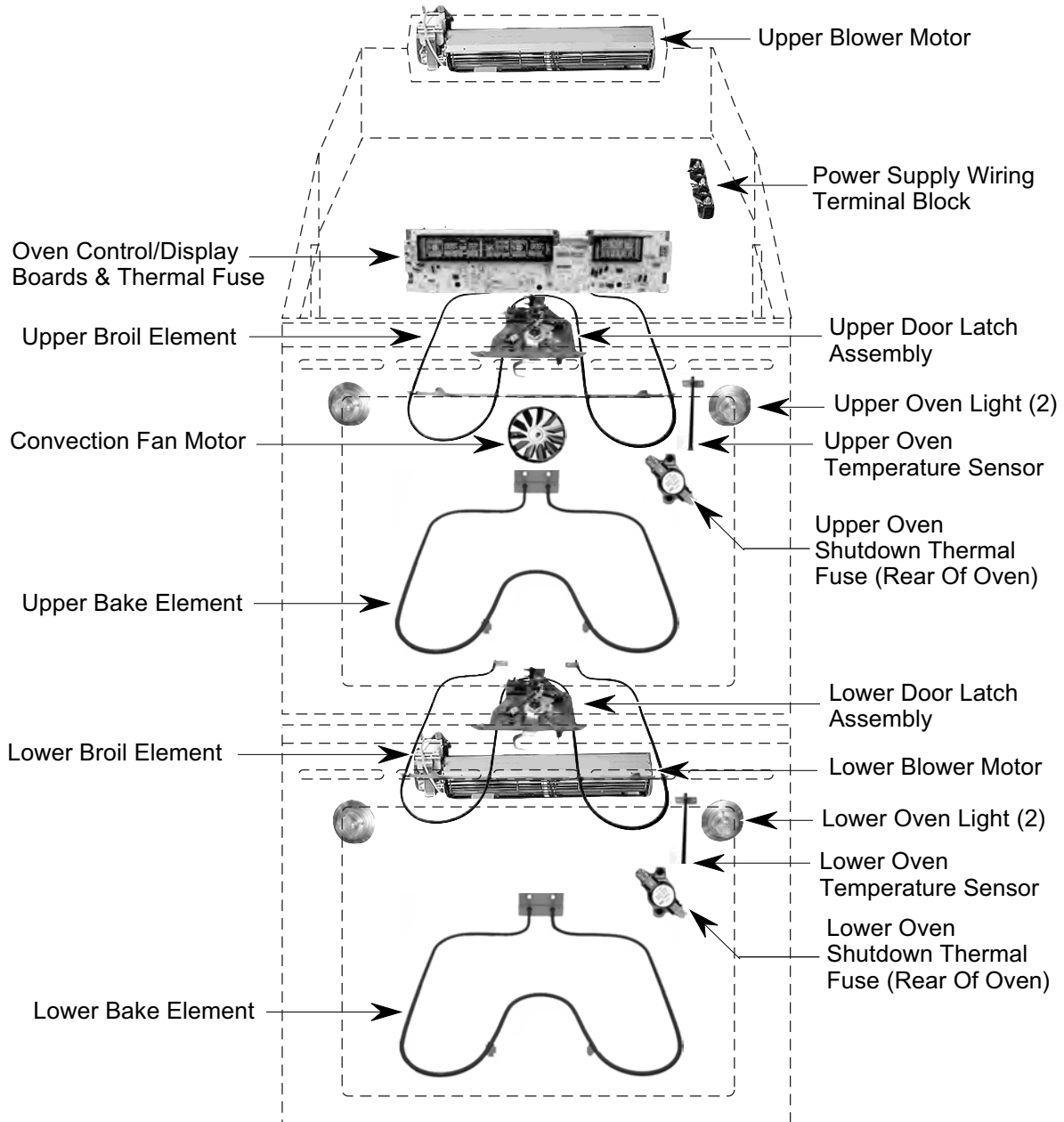

REMOVING THE THERMAL FUSE, THE OVEN CONTROL/ DISPLAY BOARDS, AND THE TOUCH PANEL ASSEMBLY

⚠️ WARNING

Electrical Shock Hazard

Disconnect power before servicing.
 Replace all panels before operating.
 Failure to do so could result in death or electrical shock.

CAUTION: When you work on the double oven, be careful when handling the sheet metal parts. Sharp edges may be present, and you can cut yourself if you are not careful.

1. Disconnect the electrical power to the double oven.
2. Open the lower oven door.
3. Remove the bottom screw from each of the two side trim pieces (see below).
4. To remove the side trim, pull the bottom out approximately 2", and slide the top down to free it from the control panel.



Side Trim Screw
(1 On Each Side)



Pull Out Bottom
Of Side Trim

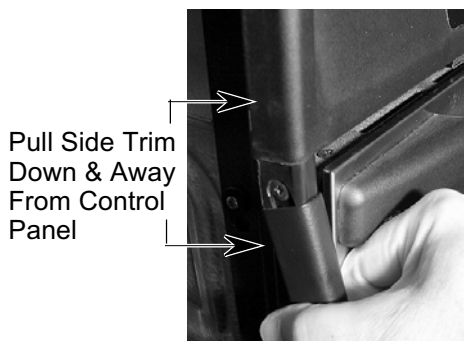

Pull Side Trim
Down & Away
From Control
Panel

5. Remove the screws from the oven control panel.

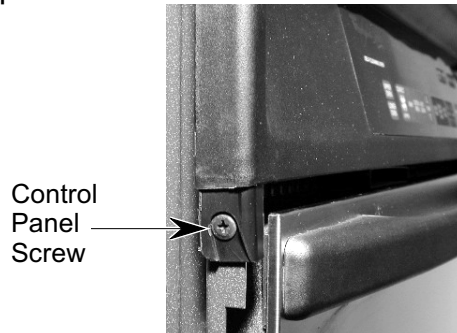

Control
Panel
Screw

6. To remove the oven control panel, pull it out at the bottom, and lift and unhook it from the oven cabinet support at the top.

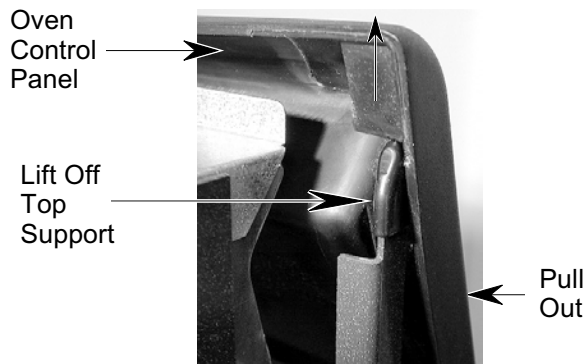

Oven
Control
Panel

Lift Off
Top
Support

Pull
Out

7. Disconnect the wire connectors from the control board and set the panel face down on a padded surface to protect the finish.

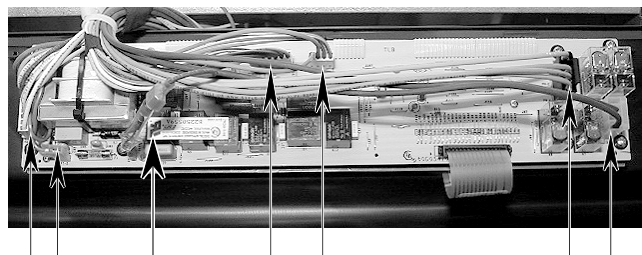

Thermal Fuse

6 Wire Connectors



Harness
Connector

8. To remove the thermal fuse, disconnect it from the main harness connector.

9. **To remove the oven control/display boards:**

- a) Remove the mounting screws.
- b) Lift the ends of the locking arm and disconnect the ribbon cable from its connector.

NOTE: The control and display boards are designed to be replaced as an assembly.

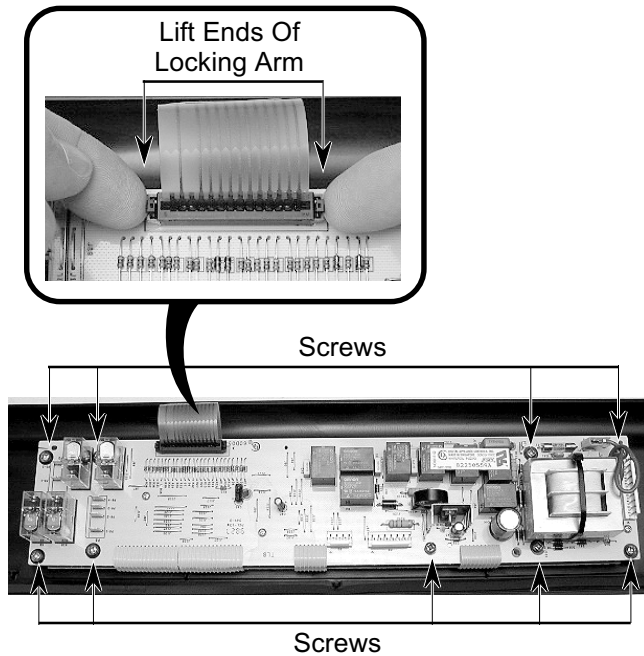

10. **To remove the touch panel assembly:**

- a) Push the window and flat ribbon cable area out of the control panel so you can grasp the edge of the touch panel on the other side.

Push Out Touch Panel At These 3 Locations

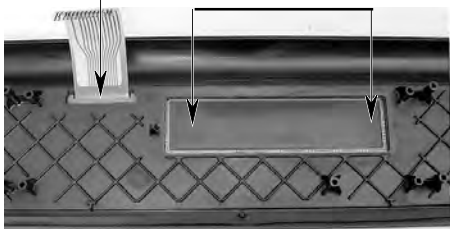

- b) Lift and peel the touch panel assembly off the front of the control panel.



REASSEMBLY NOTE: When you reinstall the oven control panel, use the following procedure (refer to the photos on the previous page, as necessary):

1. Reconnect the wiring to the control board terminals.
2. Hook the ends of the control panel over the rubber tips of the brackets.
3. Push the bottom of the control panel in and position the plastic air duct under the lip of the panel.

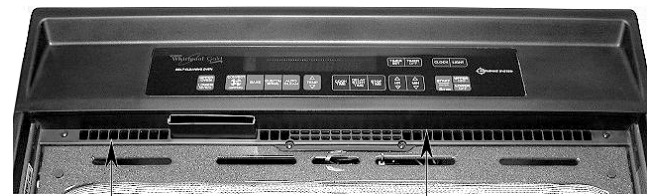

Air Duct Bottom Lip Of Control Panel

4. Align the mounting holes and install the two side screws in the control panel.

IMPORTANT NOTE: "Cavity size" connectors (see the photo below) are provided on connector P3. The connector on the end of the yellow wire is coming from pin 9, and the connector on the end of the orange wire is coming from pin 10. This cavity size connector determines the various cycling of the cooking relays in the 27" and 30" ovens. Be sure to observe the proper cavity size configuration for the oven you are servicing.

24" ovens = Open connection

27" ovens = Tan wire to Orange wire

30" ovens = Tan wire to Yellow wire

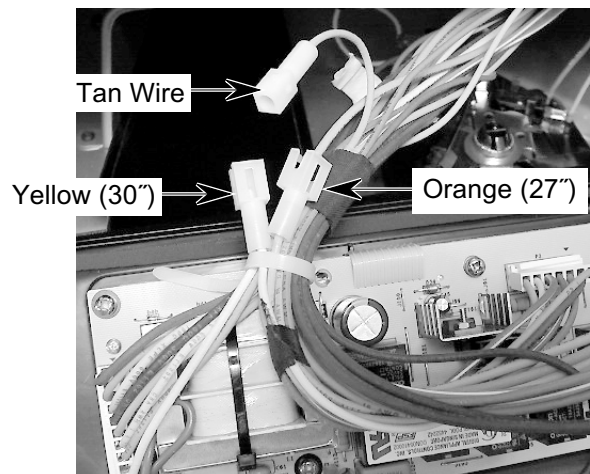

REMOVING THE POWER SUPPLY WIRING TERMINAL BLOCK AND THE UPPER & LOWER BLOWER MOTORS

! WARNING

Electrical Shock Hazard

Disconnect power before servicing.
Replace all panels before operating.
Failure to do so could result in death or electrical shock.

CAUTION: When you work on the double oven, be careful when handling the sheet metal parts. Sharp edges may be present, and you can cut yourself if you are not careful.

1. Disconnect the electrical power to the double oven.
2. Remove the side trim from the oven (see page 4-2, steps 1 through 4 for the procedure).

NOTE: Before you move the double oven from its mounting location, remove both oven doors to make it easier to move (see page 2-3 for the procedure).

3. Remove the four double oven cabinet mounting screws (2 on each side), and pull the oven out of its mounting location so that you can access the back.



Cabinet Mounting Screw
(2 Screws On Each Side)

4. Remove the screw from the conduit clamp and remove the clamp.
5. Remove the 6 screws from the top rear oven cabinet cover.

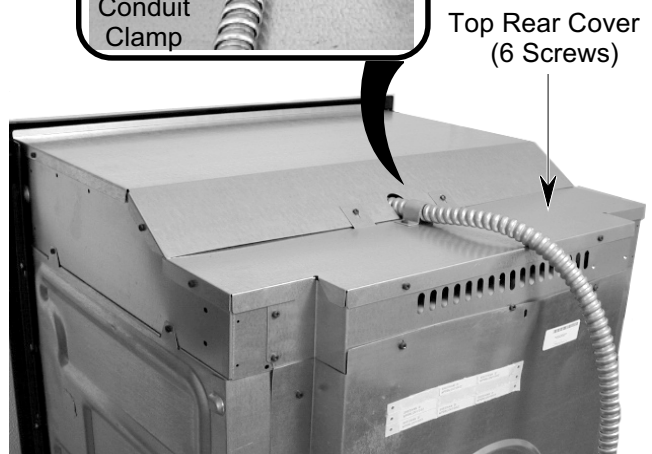
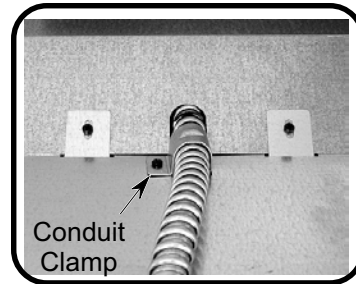

6. **To remove the power supply wiring terminal block:**
 - a) Remove the hex nuts from the wire terminal studs and remove the wires from the studs.
 - b) Remove the two mounting screws from the terminal block and remove it from the top of the oven.

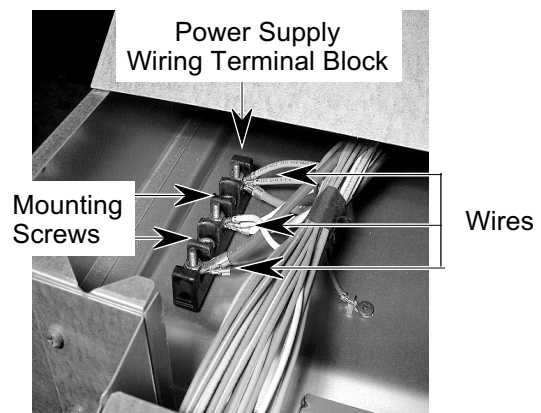

7. To remove the upper blower motor assembly:

- a) Remove the upper rear cover from the oven (11 screws) .



- b) Remove the four screws from the blower cover and remove the cover.

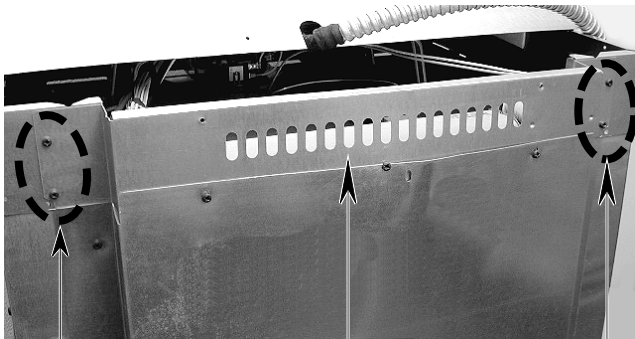

2 Screws Blower Cover 2 Screws

- c) Disconnect the two wires from the upper blower motor terminals.

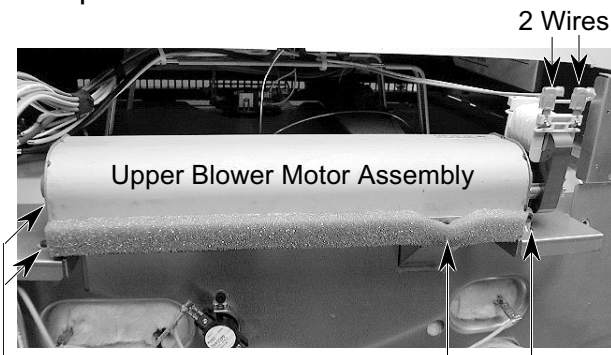

4 Mounting Screws

- d) Remove the four mounting screws.

8. To remove the lower blower motor assembly:

- a) Remove the upper rear cover (see step 7a) and the lower rear cover (8 screws).

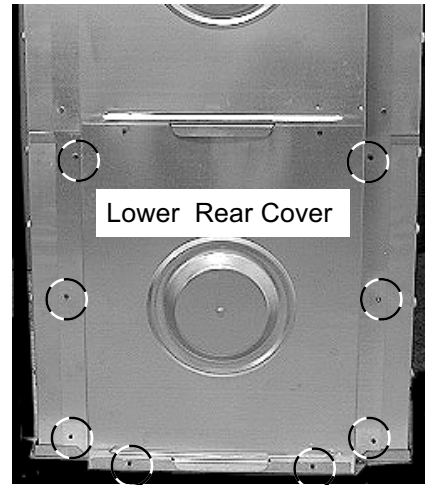

- b) Disconnect the two wires from the lower blower motor terminals.

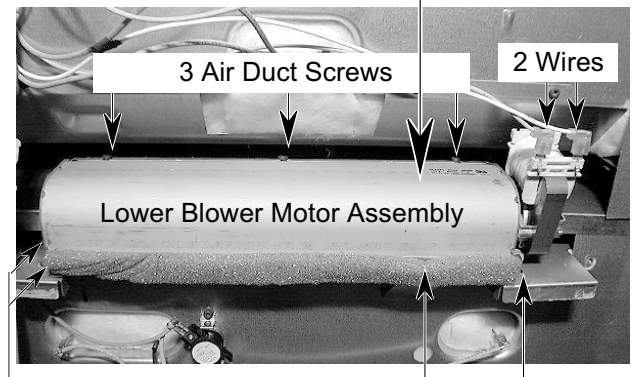
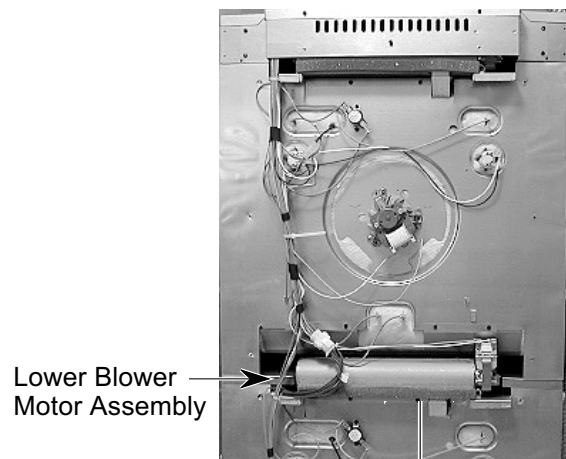

4 Mounting Screws

- c) Remove the three air duct screws and the four mounting screws.

REMOVING THE UPPER & LOWER OVEN DOOR LATCH ASSEMBLY

! WARNING

Electrical Shock Hazard

Disconnect power before servicing.
Replace all panels before operating.
Failure to do so could result in death or electrical shock.

CAUTION: When you work on the double oven, be careful when handling the sheet metal parts. Sharp edges may be present, and you can cut yourself if you are not careful.

1. Disconnect the electrical power to the double oven.
2. **To remove the upper oven door latch assembly:**
 - a) Remove the control panel from the oven (see page 4-2, steps 1 through 6 for the procedure).
 - b) Open the upper oven door and remove the two front mounting screws from the upper air vent.

Upper Oven Door Latch Assembly

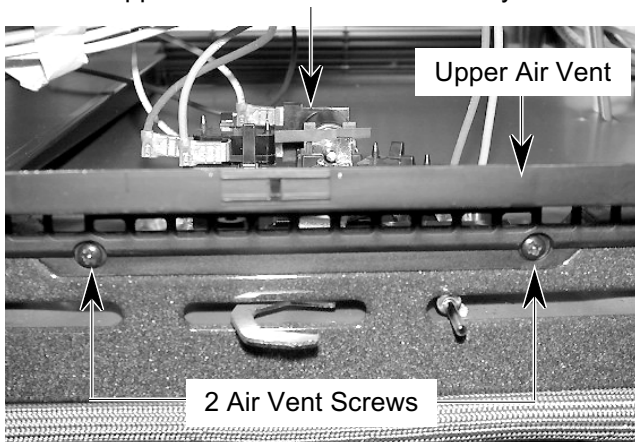

- c) Remove the wires from the terminals of the solenoid and the two switches.
- d) Remove the two top screws from the upper oven door latch assembly and remove the assembly.

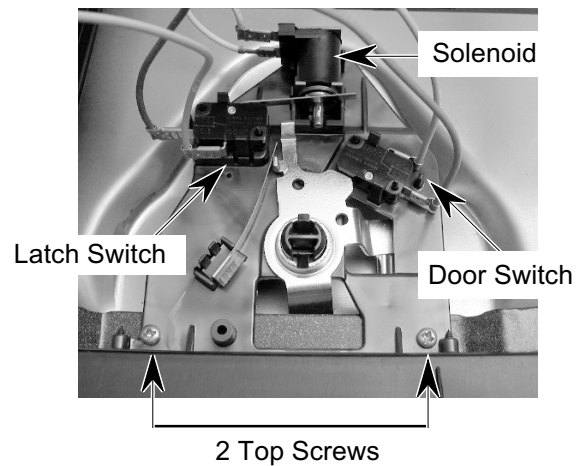

3. **To remove the lower oven door latch assembly:**
 - a) Open the lower oven door
 - b) Remove the two screws from the lower air vent and remove the vent.



- c) Remove the 3 lower air duct cover screws.

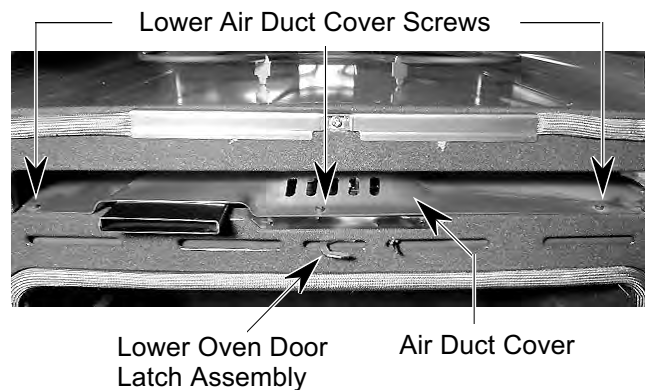

- d) Raise the lower air duct cover and remove the two screws from the lower oven door latch assembly.



- e) Remove the lower oven door latch assembly and disconnect the wires from the two switches and the solenoid terminals.

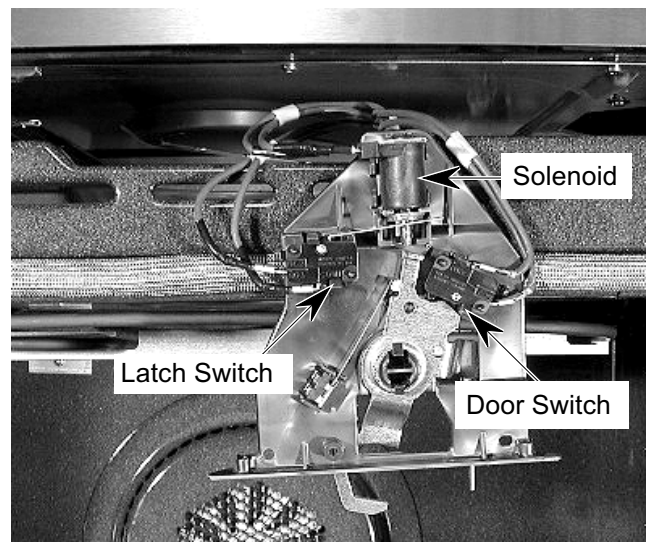
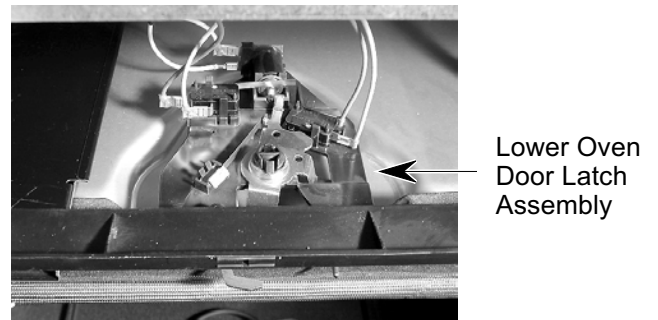

REMOVING AN OVEN LIGHT & AN OVEN TEMPERATURE SENSOR

! WARNING

Electrical Shock Hazard

Disconnect power before servicing.
Replace all panels before operating.
Failure to do so could result in death or electrical shock.

CAUTION: When you work on the double oven, be careful when handling the sheet metal parts. Sharp edges may be present, and you can cut yourself if you are not careful.

1. Disconnect the electrical power to the double oven.
2. Open the oven door and remove the racks from inside the oven.

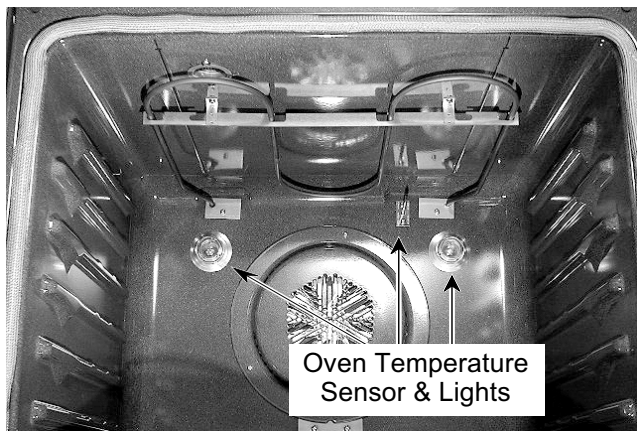

3. To remove an oven light:

- a) Unscrew the lens and remove the lens, the decorative ring, and the bulb from the socket.

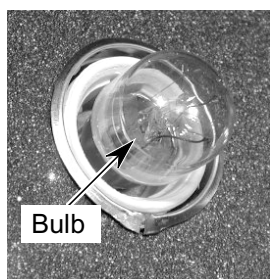
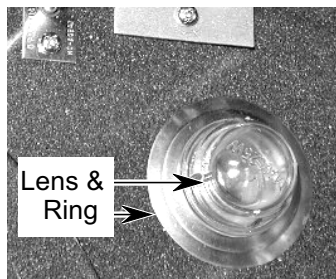

- b) Pry the socket ring and socket out of the oven cavity hole. Press in on the socket ring locking arms with a flat screwdriver to release them.

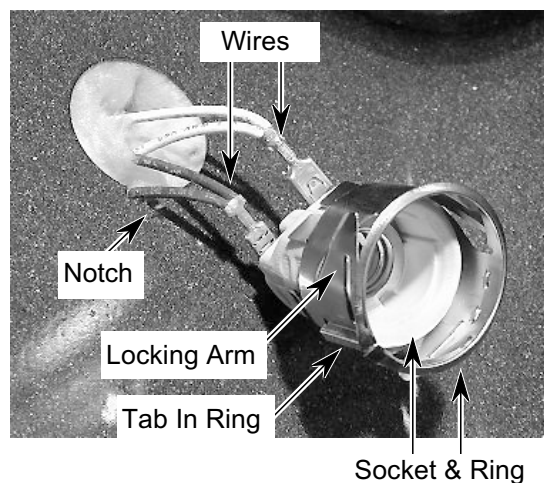

- c) Disconnect the wires from the light socket terminals.

REASSEMBLY NOTE: When you snap the socket ring into the liner, position the ring tab in the notch at the bottom of the hole.

4. To remove the oven temperature sensor:

- a) Remove the two mounting screws from the oven temperature sensor and pull the connectors out of the mounting hole in the oven liner.
- b) Disconnect the sensor connector from the main wire harness connector.

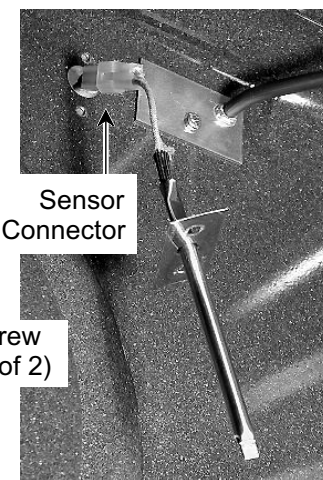
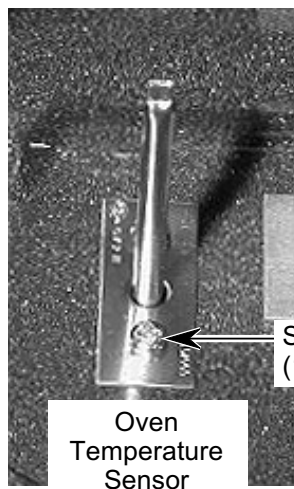

REMOVING A BROIL ELEMENT

! WARNING

Electrical Shock Hazard

Disconnect power before servicing.
Replace all panels before operating.
Failure to do so could result in death or electrical shock.

CAUTION: When you work on the double oven, be careful when handling the sheet metal parts. Sharp edges may be present, and you can cut yourself if you are not careful.

1. Disconnect the electrical power to the double oven.
2. Open the oven door and remove the racks from inside the oven.

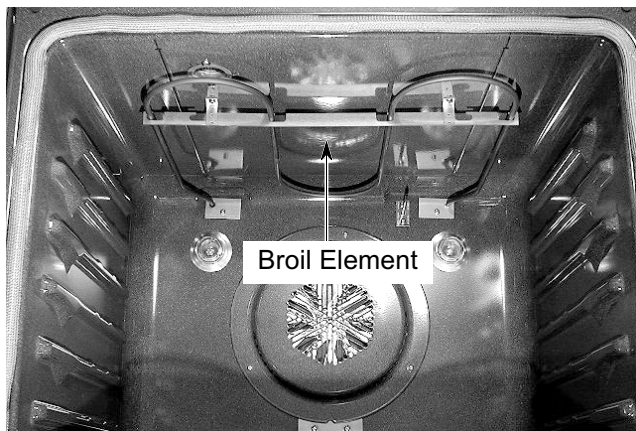

3. Remove the two front bracket screws and two rear bracket screws from the broil element.

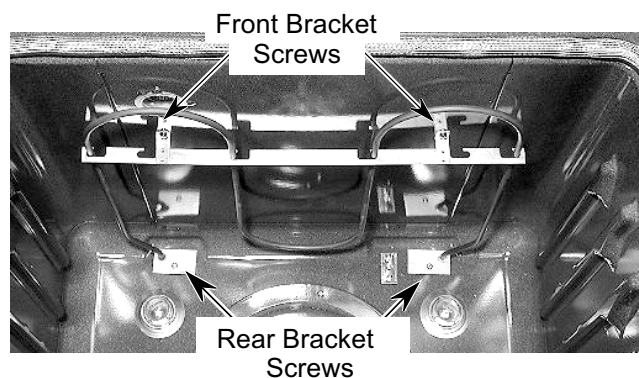

4. Carefully pull the element forward so that the terminal connectors are through the oven liner holes, and disconnect the wires from the terminals.

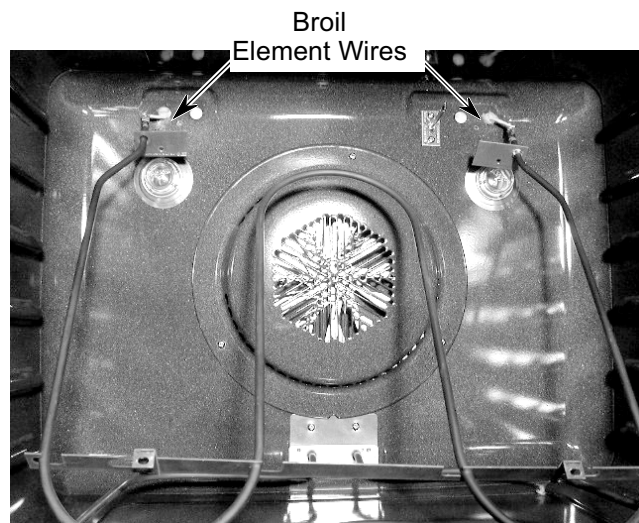

REMOVING A BAKE ELEMENT

! WARNING

Electrical Shock Hazard

Disconnect power before servicing.
Replace all panels before operating.
Failure to do so could result in death or electrical shock.

CAUTION: When you work on the double oven, be careful when handling the sheet metal parts. Sharp edges may be present, and you can cut yourself if you are not careful.

1. Disconnect the electrical power to the double oven.
2. Open the oven door and remove the racks from inside the oven.

3. Remove the two screws from the bake element bracket.

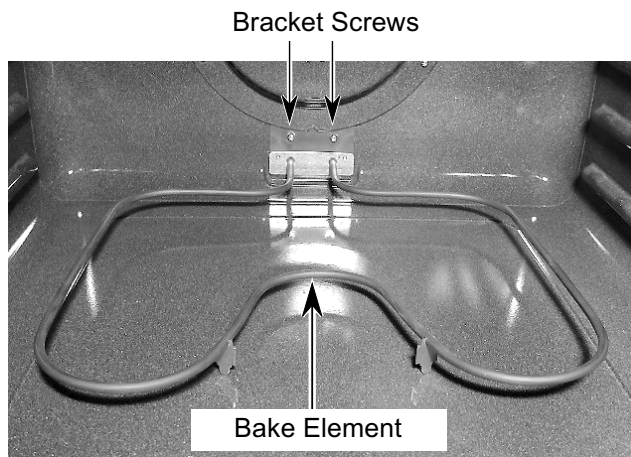

4. Carefully pull the bake element forward so that you can access the wires and then disconnect the wires from the terminals.

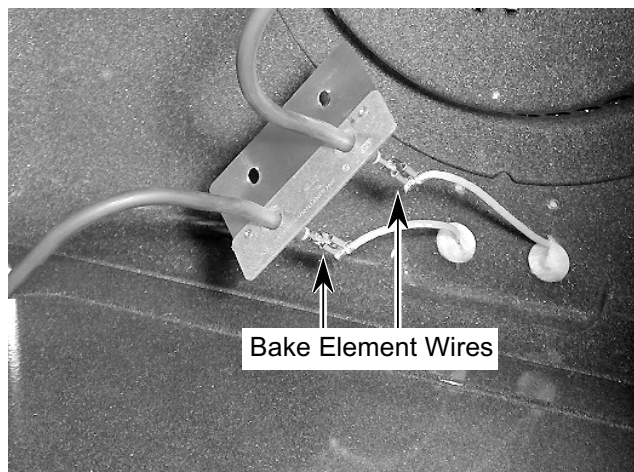

REMOVING AN OVEN SHUTDOWN THERMAL FUSE

! WARNING

Electrical Shock Hazard

Disconnect power before servicing.
Replace all panels before operating.
Failure to do so could result in death or electrical shock.

CAUTION: When you work on the double oven, be careful when handling the sheet metal parts. Sharp edges may be present, and you can cut yourself if you are not careful.

1. Disconnect the electrical power to the double oven.
2. Pull the oven out of its mounting location, (see page 4-4 steps 1 through 3 for the procedure), so that you can access the rear covers.
3. Depending on the thermal fuse you are servicing, remove the upper or lower rear cover from the oven (see page 4-5 for the procedure).

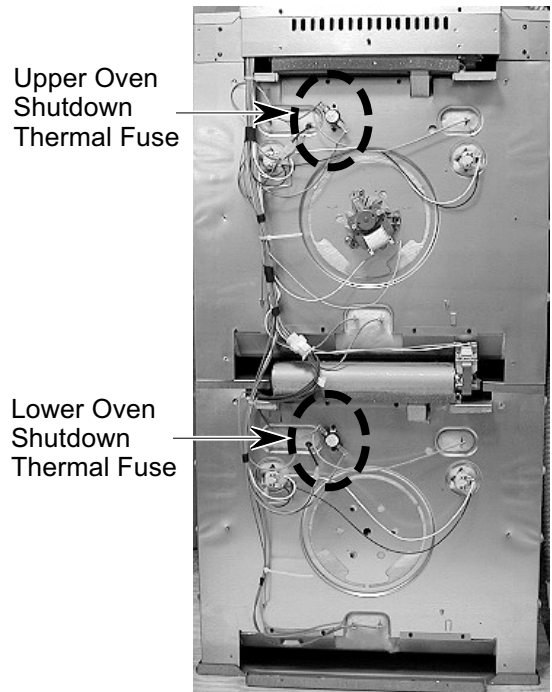

4. Disconnect the wires from the thermal fuse terminals.

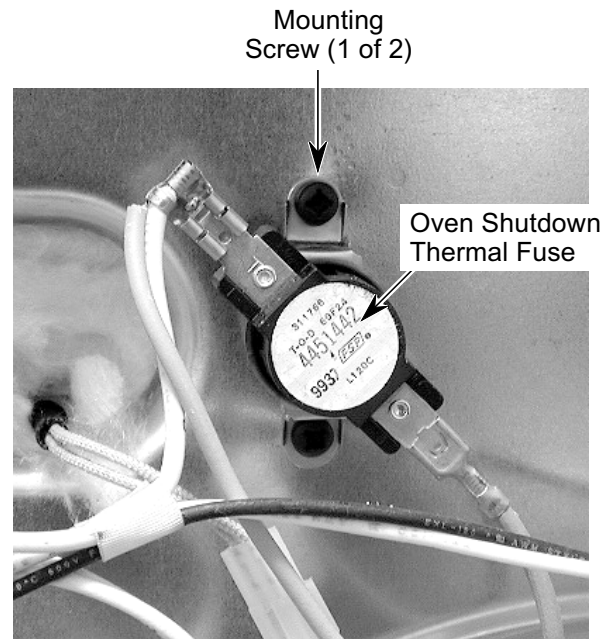

5. Remove the two screws and remove the fuse from the rear of the oven.

REMOVING THE CONVECTION FAN MOTOR ASSEMBLY

! WARNING

Electrical Shock Hazard

Disconnect power before servicing.
Replace all panels before operating.
Failure to do so could result in death or electrical shock.

CAUTION: When you work on the double oven, be careful when handling the sheet metal parts. Sharp edges may be present, and you can cut yourself if you are not careful.

1. Disconnect the electrical power to the double oven.
2. To make servicing easier, remove the upper oven door from the unit (see page 2-3 for the procedure).
3. Remove the racks from inside the oven.

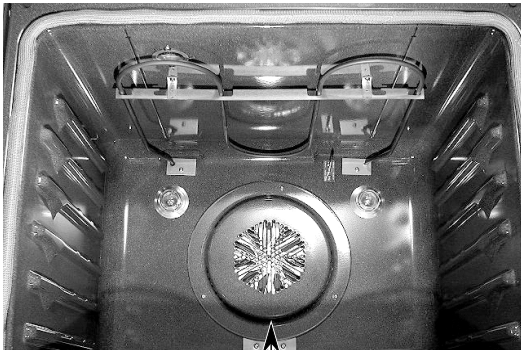

Convection Fan Motor

4. Remove the three screws from the convection fan motor cover and remove the cover from the rear of the oven liner. Note the location of the notch in the cover. Be

sure to position the cover with the notch as shown when you reinstall it.

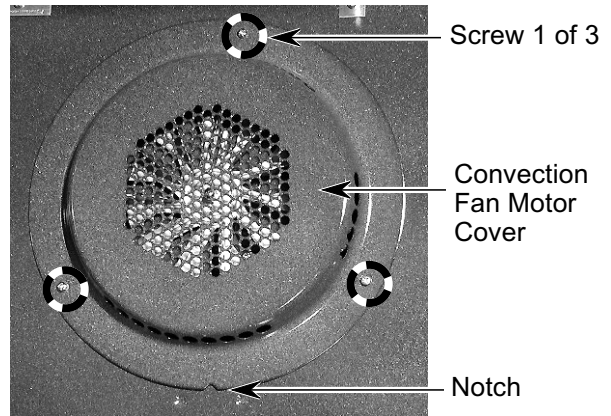

5. Use a 10 mm (7/16") socket and remove the hex nut from the convection fan. **NOTE:** The nut has a left-rotation thread for removal.

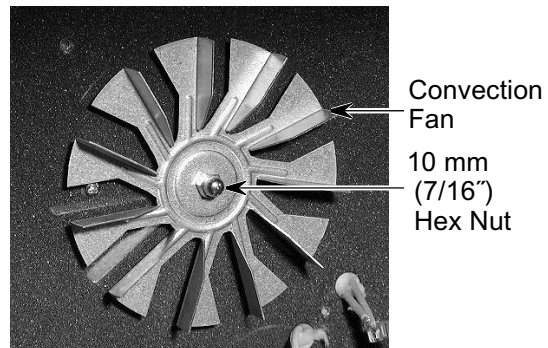

6. Remove the three front convection fan motor screws from the rear of the oven liner.

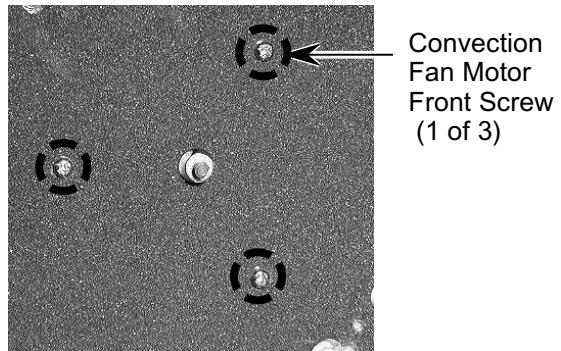

7. Pull the oven out of its mounting location (see page 4-4, steps 1 through 3 for the procedure) so that you can access the rear covers.
8. Remove the upper rear cover from the oven (see page 4-5, step 7a for the procedure).
9. Remove the two rear convection fan motor mounting screws from the oven, and remove the motor from the rear of the oven.

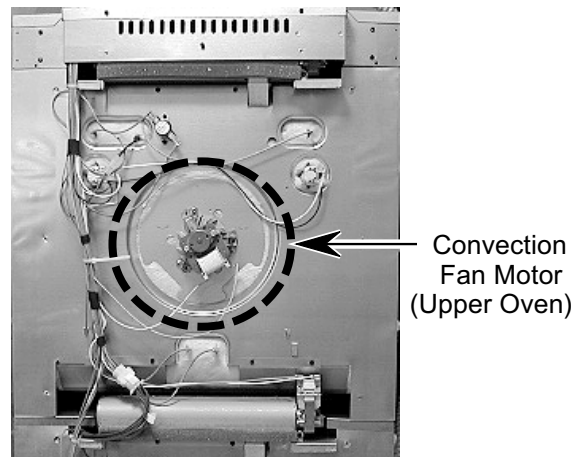

Convection Fan Motor
Rear Screw (1 of 2)

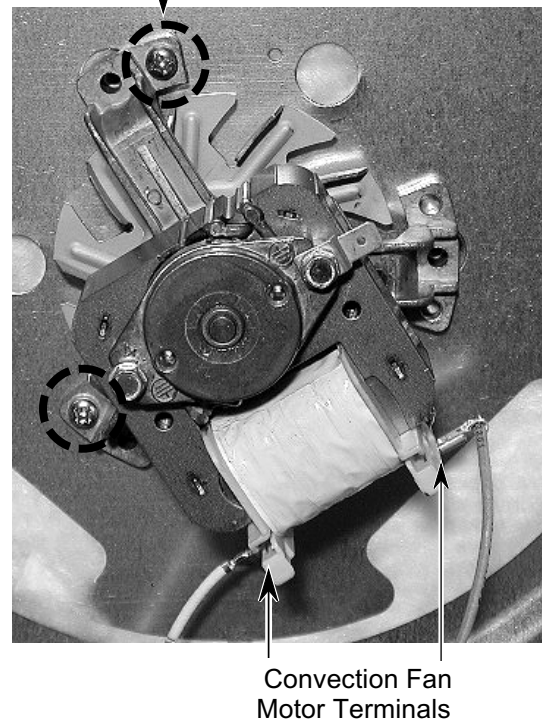

REMOVING THE OVEN DOOR GLASS, HINGES, & HANDLE

CAUTION: When you work on the double oven, be careful when handling the sheet metal parts. Sharp edges may be present, and you can cut yourself if you are not careful.

1. Remove the oven door from the oven (see page 2-3 for the procedure).
2. Place the oven door on a padded work surface with the front decorative glass facing down.
3. Remove the two top door liner screws and the two door glass bracket screws, and lift the liner assembly off the decorative door glass and handle.

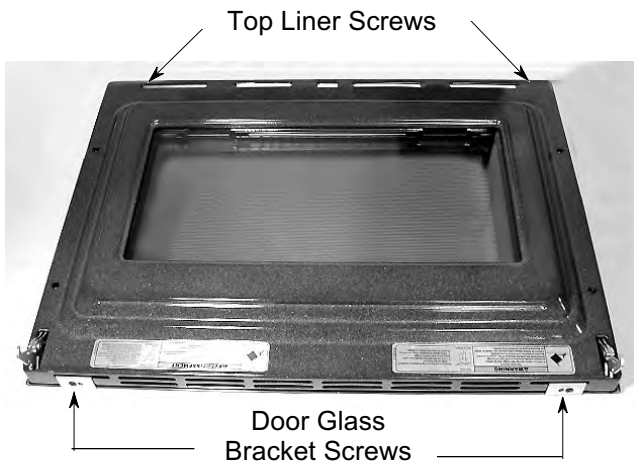

4. **To remove the outer door glass:**
 - a) Remove the three outer glass holder screws and two outer glass bracket screws from the door liner.
 - b) Lift the outer glass with the glass holder off the door liner.
 - c) Remove the bracket.

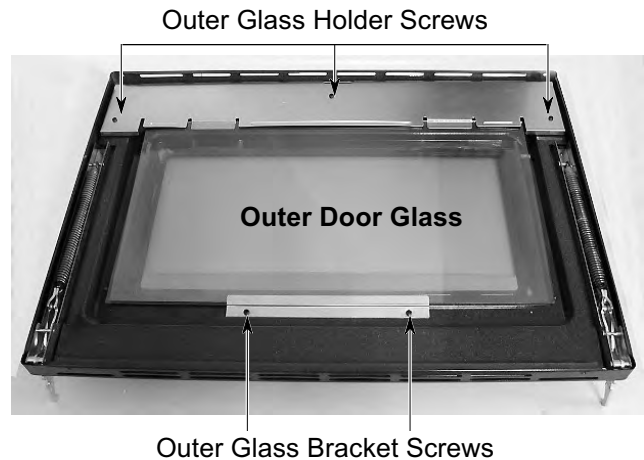

5. **To remove the center door glass,** remove the bottom bracket, (it is loose), and slide the two top corners of the glass out of the door liner slots.

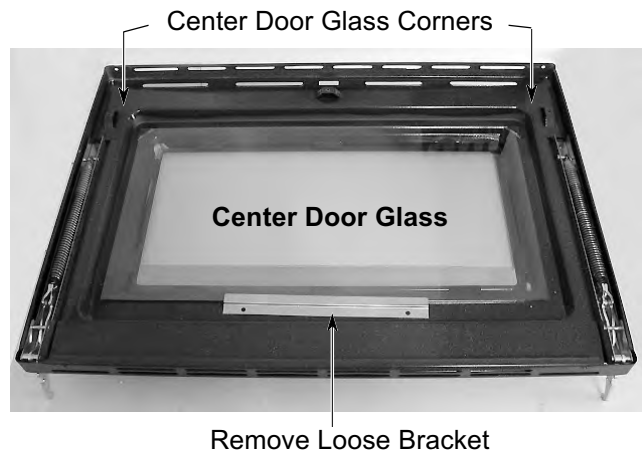

6. **To remove the hinges and the inner door glass:**

NOTE: You will have to remove both hinges to remove the inner door glass from the oven door liner.

- a) Lift either side of the door liner, remove the two door hinge screws, and remove the hinge.



- b) Lift the other side of the door liner, remove the two screws for the other hinge, and remove the hinge.
- c) Lift the inner door glass liner cover off the liner.

- d) Remove the insulation and the inner door glass.



7. **To remove the door handle,** remove the two door handle screws from the bracket.

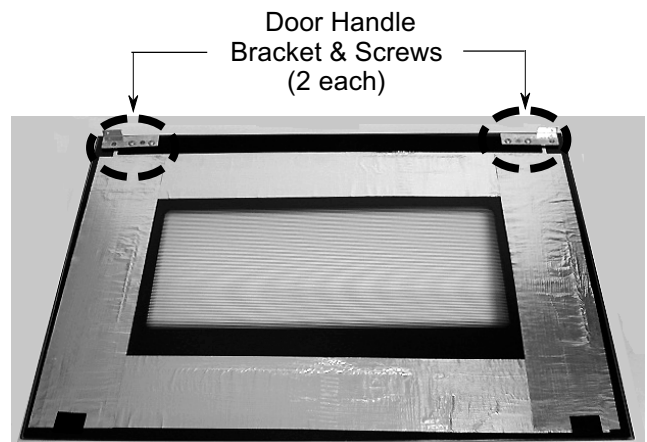

REMOVING THE OVEN DOOR GASKET

CAUTION: When you work on the double oven, be careful when handling the sheet metal parts. Sharp edges may be present, and you can cut yourself if you are not careful.

1. Open the oven door to its fully open position.
2. Remove the screw from the door gasket bracket and remove the bracket from the oven.

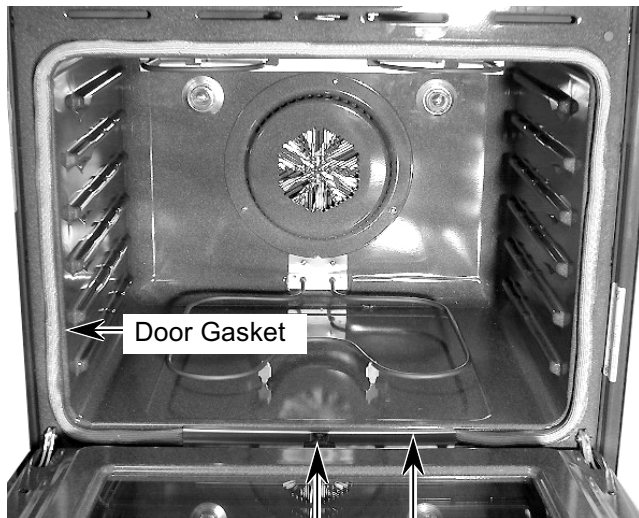

Screw Gasket Bracket

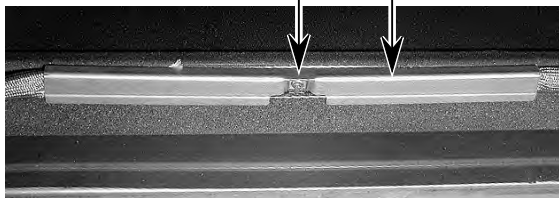

3. Pull the ends of the gasket out of the liner holes and pull the clips out of their liner holes.

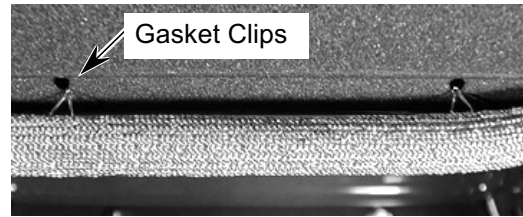

REASSEMBLY NOTE: When you install the new gasket, make sure that all of the clips are seated in their liner holes, and that the ends of the gasket are pushed fully into their holes. Use the pointed end of a pencil to push the gasket ends into the holes.

COMPONENT TESTING

Before testing any of the components, perform the following checks:

- The most common cause for control failure is corrosion on connectors. Therefore, disconnecting and reconnecting wires will be necessary throughout test procedures.
- All tests/checks should be made with a VOM or DVM having a sensitivity of 20,000 ohms-per-volt DC, or greater.

- Check all connections before replacing components, looking for broken or loose wires, failed terminals, or wires not pressed into connectors far enough.
- Voltage checks must be made with all connectors attached to the boards.
- Resistance checks must be made with power cord unplugged from outlet, and with wiring harness or connectors disconnected.

! WARNING

Electrical Shock Hazard

Disconnect power before servicing.
Replace all panels before operating.
Failure to do so could result in death or electrical shock.

! WARNING

Electrical Shock Hazard

Disconnect power before servicing.
Replace all panels before operating.
Failure to do so could result in death or electrical shock.

BLOWER MOTORS

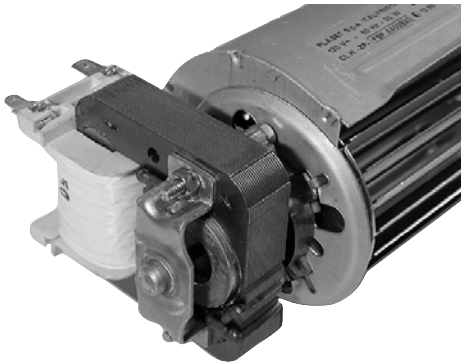

Refer to page 4-4 for the procedure for servicing the upper & lower blower motors.

1. Disconnect the electrical power to the double oven.
2. Disconnect the wires from the blower motor terminals.
3. Set the ohmmeter to the R x 1 scale.
4. Touch the ohmmeter leads to the motor terminals. The meter should indicate between 10 and 18 Ω .

OVEN TEMPERATURE SENSOR



Refer to page 4-8 for the procedure for servicing an oven temperature sensor.

1. Disconnect the electrical power to the double oven.
2. Disconnect the oven temperature sensor connector from the oven connector.
3. Set the ohmmeter to the R x 1K scale.
4. Touch the ohmmeter leads to the sensor connector pins. The meter should indicate 1080 Ω @ 70°F.

! WARNING

Electrical Shock Hazard

Disconnect power before servicing.
Replace all panels before operating.
Failure to do so could result in death or electrical shock.

CONVECTION FAN MOTOR

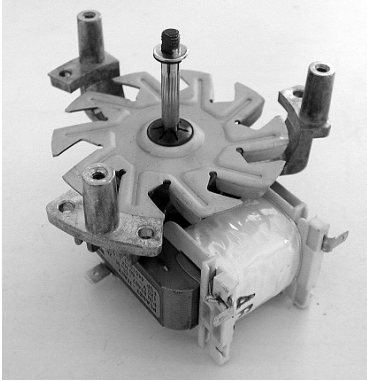

Refer to page 4-12 for the procedure for servicing the convection fan motor.

1. Disconnect the electrical power to the double oven.
2. Disconnect the wires from the convection fan motor terminals.
3. Set the ohmmeter to the R x 1 scale.
4. Touch the ohmmeter leads to the motor terminals. The meter should indicate between 13 and 20 Ω .

! WARNING

Electrical Shock Hazard

Disconnect power before servicing.
Replace all panels before operating.
Failure to do so could result in death or electrical shock.

OVEN SHUTDOWN THERMAL FUSE

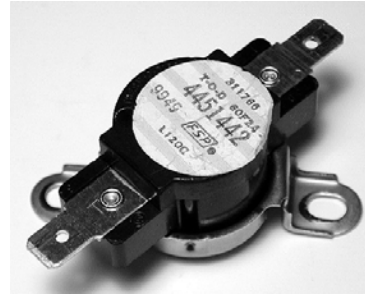

Refer to page 4-11 for the procedure for servicing an oven shutdown thermal fuse.

1. Disconnect the electrical power to the double oven.
2. Disconnect the wires from the oven shutdown thermal fuse terminals.
3. Set the ohmmeter to the R x 1 scale.
4. Touch the ohmmeter leads to the oven shutdown thermal fuse terminals. The meter should indicate continuity (closed circuit).

! WARNING

Electrical Shock Hazard

Disconnect power before servicing.
Replace all panels before operating.
Failure to do so could result in death or electrical shock.

BROIL ELEMENT

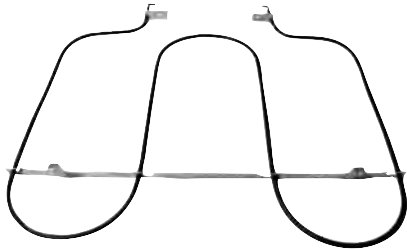

Refer to page 4-9 for the procedure for servicing a broil element.

1. Disconnect the electrical power to the double oven.
2. Disconnect the wires from the broil element terminals.
3. Set the ohmmeter to the R x 1 scale.
4. Touch the ohmmeter leads to the broil element terminals. The meter should indicate between 15 and 20 Ω .

! WARNING

Electrical Shock Hazard

Disconnect power before servicing.
Replace all panels before operating.
Failure to do so could result in death or electrical shock.

BAKE ELEMENT

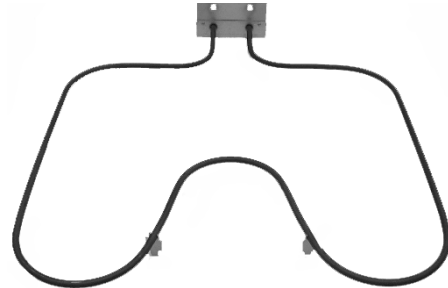

Refer to page 4-10 for the procedure for servicing a bake element.

1. Disconnect the electrical power to the double oven.
2. Disconnect the wires from the bake element terminals.
3. Set the ohmmeter to the R x 1 scale.
4. Touch the ohmmeter leads to the element terminals. The meter should indicate between 22 & 30 Ω .

! WARNING

Electrical Shock Hazard

Disconnect power before servicing.
Replace all panels before operating.
Failure to do so could result in death or electrical shock.

OVEN DOOR LATCH ASSEMBLY

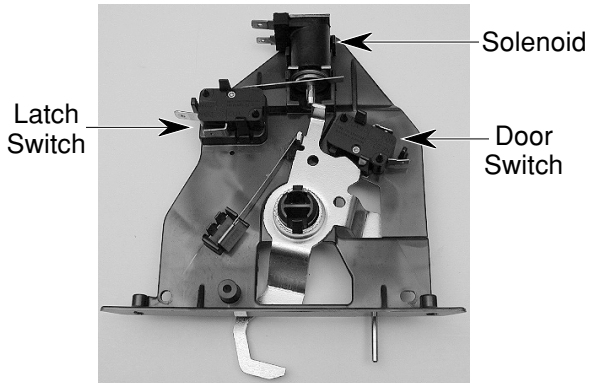

Refer to page 4-6 for the procedure for servicing an oven door latch assembly.

1. Disconnect the electrical power to the double oven.
2. Disconnect the wires from the door latch assembly component under test.
3. Set the ohmmeter to the R x 1 scale.
4. **To test the solenoid**, touch the ohmmeter leads to the terminals. The meter should indicate between 47 and 54 Ω .
5. **To test the door or latch switch:**
 - a) Touch the ohmmeter leads to the following terminals (shown embossed on the switch). The meter should indicate:
COM to N.O. = infinity (no continuity)
COM to N.C. = 0 Ω (continuity)
 - b) Press the switch actuator button and touch the ohmmeter leads to the following terminals. The meter should indicate:
COM to N.O. = 0 Ω (continuity)
COM to N.C. = infinity (no continuity)

! WARNING

Electrical Shock Hazard

Disconnect power before servicing.
Replace all panels before operating.
Failure to do so could result in death or electrical shock.

CONTROL PANEL THERMAL FUSE

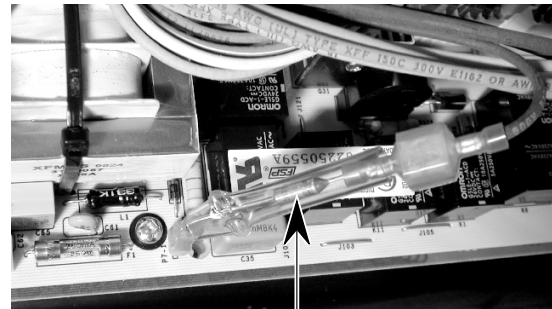

Control Panel Thermal Fuse

Refer to page 4-2 for the procedure for servicing the control panel thermal fuse.

1. Disconnect the electrical power to the double oven.
2. Set the ohmmeter to the R x 1 scale.
3. Touch the ohmmeter leads to the control panel thermal fuse leads at P7-1 and the main harness connector. The meter should indicate continuity (closed circuit).

DIAGNOSIS & TROUBLESHOOTING

DIAGNOSTICS

Before servicing, perform the following checks:

- The most common cause for control failure is corrosion on connectors. Therefore, disconnecting and reconnecting wires will be necessary throughout test procedures.
- All tests/checks should be made with a VOM or DVM having a sensitivity of 20,000 ohms-per-volt DC, or greater.
- Check all connections before replacing components, looking for broken or loose wires, failed terminals, or wires not pressed into connectors far enough.
- Voltage checks must be made with all connectors attached to the boards.
- Resistance checks must be made with power cord unplugged from outlet, and with wiring harness or connectors disconnected.

FAHRENHEIT (° F) TO CELSIUS (° C) CONVERSION

The default is Fahrenheit (° F).

1. Press the BROIL pad for 5 seconds. The temperature will be displayed in degrees Celsius indicated by the "C" in the temperature display.
2. To return the display to degrees Fahrenheit press the BROIL pad again for 5 seconds. "F" will show in the temperature display.

PROGRAMMING THE CAVITY SIZE

When replacing the electronic control, be sure to program the cavity size:

1. Within 60 seconds of power up, press the following touchpads:
LOWER OFF, UPPER OVEN, BAKE, TEMP DOWN, TIMER OFF, MINUTE DOWN, START, CLOCK, LIGHT.
2. The size is shown in the display "-ID 24."

3. Press the CLOCK touchpad until the correct size is displayed.
4. Press the CANCEL touchpad.
5. Press and hold the LOWER OFF touchpad for 5 seconds to verify the programming.

ELECTROSTATIC DISCHARGE (ESD) SENSITIVE ELECTRONICS

ESD problems are present everywhere. ESD may damage or weaken the electronic control assembly. The new control assembly may appear to work well after repair is finished, but failure may occur at a later date due to ESD stress.

- Use an anti-static wrist strap. Connect wrist strap to green ground connection point or unpainted metal in the appliance

-OR-

Touch your finger repeatedly to a green ground connection point or unpainted metal in the appliance.

- Before removing the part from its package, touch the anti-static bag to a green ground connection point or unpainted metal in the appliance.
- Avoid touching electronic parts or terminal contacts; handle electronic control assembly by edges only.
- When repackaging failed electronic control assembly in anti-static bag, observe above instructions.

FAILURE/ERROR DISPLAY CODES TECH SHEETS 4451887C & 4451888A

- Always disconnect the power to the unit before touching the internal parts of the oven.

- Upon replacement, immediately return the old electronic oven control. Use the mailing label that is supplied with each new control.
- For double ovens, the failure code is displayed on the side of the display that corresponds to the oven with faulty part (upper oven = left side of display).

FAULT CODE	ERROR CODE	CODE EXPLANATION	RECOMMENDED REPAIR PROCEDURE
F0		Default F code - no failure	Will only be displayed if user presses and holds "UPPER OFF" key for 5 seconds and there is no pre-existing fault. Press CANCEL to clear display.
F1	All E Codes	Electronic control malfunction	Replace control.
F2	E0	Key held down too long, or key is shorted	<ol style="list-style-type: none"> 1. Check keypad connector for firm connection. 2. Press CANCEL. If error code returns after 60 sec., replace keypad. 3. Replace control.
	E1	Keypad keytail not connected	
	E5 E6	CANCEL key drive line open	
F3	E0	Temperature sensor opened	<ol style="list-style-type: none"> 1. Check sensor connection. 2. Measure sensor resistance: 1080Ω at 21° C (70° F). (Add 2Ω per degree). 3. If resistance is not valid, replace sensor. 4. If sensor resistance and connections are good, then the oven cavity temperature must have exceeded a safe level. Check for welded-closed relays on the control.
	E1	Temperature sensor shorted	
	E2	Oven temp too high - over 301° C (575° F) in COOK mode	
	E3	Oven temp too high - over 510° C (950° F) in CLEAN mode	
F4	E1	Meat probe malfunction - shorted	<ol style="list-style-type: none"> 1. Disconnect meat probe and measure probe resistance: 78k Ω @ 15.6° C (60° F); 37k Ω @ 32.2° C (90° F). 2. If resistance is not valid replace sensor. 3. Insert probe and check for a firm connection between probe and jack (in oven cavity). 4. Check connection between jack and harness (in rear of oven).
F5	E0	Door is open, but latch is locked (condition exists when door switch is closed indicating an open door, and latch switch is closed indicating a locked door).	<ol style="list-style-type: none"> 1. Check the latch assembly: latch arm pivot joint, arm/solenoid connection, solenoid spring, and spring washer. 2. Check the Latch Solenoid: <ul style="list-style-type: none"> - Check for firm electrical connections. - Disconnect the two wires from the solenoid and measure the resistance of the solenoid. A small resistance (approx. 175Ω) is normal. If the solenoid is open (∞Ω) or shorted (0Ω), it should be replaced. 3. Check the Latch Switch. Disconnect it and use a continuity tester: <ul style="list-style-type: none"> - Door latched = switch closed, continuity should read 0Ω. - Door unlatched = switch open, continuity should read ∞Ω. 4. Check Door Open/Closed Switch. Disconnect it and use a continuity tester: <ul style="list-style-type: none"> - Door open = switch closed, continuity should read 0Ω. - Door closed = switch open, continuity should read ∞Ω. 5. Check power and element connections.
	E1	Self-clean latch will not lock	
	E5	Self-clean temperature 288° C (550° F) not reached within 45 min.	
	E7	Self-clean latch will not unlock	
F6	E0	Return line not connected	If switch pulse return line not connected, electronic control will display F6 within 60 seconds after power up. Replace control.

FAILURE/ERROR DISPLAY CODES

TECH SHEET 4452022A

FAULT CODE	ERROR CODE	CODE EXPLANATION	RECOMMENDED REPAIR PROCEDURE
F0	E0	Default F code -no failure	Will only be displayed if user presses and holds CANCEL key for 5 seconds and there is no pre-existing fault. Press CANCEL again to clear display.
F1	E3	Wiring harness cavity size does not match previously stored value	The "Cavity Size Select" jumpers in the wiring harness indicate a cavity size different from that which the control was previously configured for. Check the jumpers in the harness to make sure they agree with the actual oven size.
	All Other E Codes	Electronic control malfunction	Replace control if the E code is not E3.
F2	E2	Keypad not connected	1. Check keypad connector for firm connection. 2. Press CANCEL. If error code returns after 60 sec., replace keypad.
	E3	Key held down too long, or key is shorted	
F3	E0	Temperature sensor opened	1. Check sensor connection. 2. Measure sensor resistance (1080 Ω at 70° F. Add 2 Ω per degree.) 3. If resistance is not valid, replace sensor. 4. If sensor resistance and connections are good, then the oven cavity temperature must have exceeded a safe level. Check for welded-closed relays on the control.
	E1	Temperature sensor shorted	
F5	E1	Self-clean latch will not lock	1. Check the latch assembly: latch arm pivot joint, arm/solenoid connection, solenoid spring, and spring washer. 2. Check the Latch Solenoid: - Check for firm electrical connections. - Disconnect the two wires from the solenoid and measure the resistance of the solenoid. A small resistance (approx. 175 Ω) is normal. If the solenoid is open ($\infty\Omega$) or shorted (0 Ω), it should be replaced. 3. Check the Latch Switch. Disconnect it and use a continuity tester: - Door latched = switch closed, continuity should read 0 Ω . - Door unlatched = switch open, continuity should read $\infty\Omega$. 4. Check Door Open/Closed Switch. Disconnect it and use a continuity tester: - Door open = switch closed, continuity should read 0 Ω . - Door closed = switch open, continuity should read $\infty\Omega$.
	E6	Door is open, but latch is locked	
	E7	Self-clean latch will not unlock	
F7	E1	Common switch wire is defective	Common wire (+5VDC) to latch switch, and to door switch is shorted to chassis ground or neutral. A double oven will have two of each switch and one common wire. 1. Check connections at control and at the latch switch and door switch. 2. If all connections are good, then check the individual switches as outlined for the F5 failure.

RELAY LOGIC CHART

TECH SHEETS 4451887C & 4451888A

MODES	RELAYS	BAKE & "B"	BROIL & "BR"	CONV FAN	OV LT	BLOWER
OFF	O	O	O	⊗	⊗	
■ PREHEAT-BAKE	+	+	O	⊗	X	
BAKE 24", 27" ■	+	+	O	⊗	X	
BAKE 30" ■	X	+	O	⊗	X	
BROIL 24"	O	+	O	⊗	X	
BROIL 27", 30"	O	X	O	⊗	X	
● PREHEAT-CONV	X	+	X	⊗	X	
CONV ●	+	+	X	⊗	X	
▲ PREHEAT-CLEAN	+	+	O	O	X	
CLEAN ▲	X	+	O	O	X	

RELAY LOGIC KEY

- O = OFF
- X = ON
- +
- ⊗ = ON OR OFF

RELAY LOGIC CHART

TECH SHEET 4452022A

MODES	RELAYS	BAKE	BROIL	CONV FAN	OV LT	BLOWER	PULSE RELAY	LOCK/UNLOCK
OFF	O	O	O	⊗	⊗	O	O	
■ PREHEAT-BAKE	+	+	O	⊗	X	O	O	
BAKE 24", 27" ■	+	+	O	⊗	X	O	O	
BAKE 30" ■	X	+	O	⊗	X	O	O	
BROIL 24"	O	+	O	⊗	X	O	O	
BROIL 27", 30"	O	X	O	⊗	X	O	O	
● PREHEAT-CONV	X	+	X	⊗	X	O	O	
CONV ●	+	+	X	⊗	X	O	O	
▲ PREHEAT-CLEAN	+	X	O	O	X	*	*	
CLEAN ▲	X	+	O	O	X	O	O	

RELAY LOGIC KEY

- O = OFF
- X = ON
- +
- ⊗ = ON OR OFF
- * = PULSED FOR 1/2 SEC

CONTROL PANEL TEST LOCATIONS TECH SHEETS 4451887C & 4451888A

LOWER OVEN			
COMPONENTS	FRONT/REAR SERVICEABLE	CHECK POINTS	RESULTS
Door Switch	Front	P23-7 (BR/W) to P23-1 (TAN)	Door Open = Closed Circuit Door Closed = Open Circuit
Door Lock Solenoid	Front	P25-3 (Y/W) to P25-4 (GY/W)	80 Ω to 100 Ω
Oven Temperature Sensor	Front	Sensor P23-5 (V) to P23-6 (GN)	1080 Ω @ 70°F
Blower	Rear	P27-2 (GY) to Neutral (W)	10 Ω to 15 Ω
Oven Shutdown Thermal Fuse	Rear	P26-2 (OR) or P26-4 (R) to Red Wire at Terminal Block	Closed Circuit
Bake Element	Front	P26-4 (R) to Red Wire at Terminal Block	25 Ω to 30 Ω
Broil Element	Front	P26-2 (OR) to Red Wire at Terminal Block	45 Ω to 55 Ω
Latch Switch	Front	P23-8 (BU/W) to P23-1 (TAN)	Door Unlocked = Open Circuit Door Locked = Closed Circuit

UPPER OVEN			
COMPONENTS	FRONT/REAR SERVICEABLE	CHECK POINTS	RESULTS
Door Switch	Front	P23-2 (BR) to P23-1 (TAN)	Door Open = Closed Circuit Door Closed = Open Circuit
Door Lock Solenoid	Front	P25-1 (Y) to P25-2 (GY)	80 Ω to 100 Ω
Oven Temperature Sensor	Front	Sensor P23-4 (V) to P23-6 (GN)	1080 Ω @ 70°F
Blower	Rear	P24-5 (GY) to Neutral (W)	10 Ω to 15 Ω
Oven Shutdown Thermal Fuse	Rear	P18-4 (R) or P18-1 (R) to Red Wire at Terminal Block	Closed Circuit
Bake Element	Front	P18-4 (R) to Red Wire at Terminal Block	25 Ω to 30 Ω
Broil Element	Front	P18-1 (OR) to Red Wire at Terminal Block	45 Ω to 55 Ω
Convection Fan Motor	Rear	P24-6 (OR) to Neutral (W)	8 Ω to 12 Ω
Control Panel Thermal Fuse	Front	L1 (BK) to P24-3 (BK)	Closed Circuit
Latch Switch	Front	P23-3 (BU) to P23-1 (TAN)	Door Unlocked = Open Circuit Door Locked = Closed Circuit
Control Transformer	Front	Primary Winding P16-5 (R) to P16-7 (R) Secondary Winding P16-2 (BU) to P16-3 (BU)	75 Ω to 95 Ω 2 Ω to 4 Ω

CONTROL PANEL TEST LOCATIONS TECH SHEET 4452022A

LOWER OVEN			
COMPONENTS	FRONT/REAR SERVICEABLE	CHECK POINTS	RESULTS
Door Switch	Front	P3-5 (BR/W) to P3-1 (TAN)	Door Open = Closed Circuit Door Closed = Open Circuit
Door Lock Solenoid	Front	P4-4 (Y) to Neutral (W)	50 Ω
Oven Temperature Sensor	Front	Sensor P2-2 (V/W) to P2-1 (V/W)	1080 Ω @ 70°F
Blower (Low)	Rear	P4-3 (GY) to Neutral (W)	10 Ω to 15 Ω
Oven Shutdown Thermal Fuse	Rear	P6-1 (OR) or P6-2 (R) to Red Wire At Terminal Block	Closed Circuit
Bake Element	Front	P6-2 (R) to Red Wire At Terminal Block	25 Ω to 30 Ω
Broil Element	Front	P6-1 (OR) to Red Wire At Terminal Block	45 Ω to 55 Ω

UPPER OVEN			
COMPONENTS	FRONT/REAR SERVICEABLE	CHECK POINTS	RESULTS
Door Switch	Front	P3-3 (BR) to P3-1 (TAN)	Door Open = Closed Circuit Door Closed = Open Circuit
Door Lock Solenoid	Front	P4-7 (Y) to Neutral (W)	50 Ω
Oven Temperature Sensor	Front	Sensor P2-3 (V) to P2-4 (V)	1080 Ω @ 70°F
Blower	Rear	P4-6 (GY) to Neutral (W)	10 Ω to 15 Ω
Oven Shutdown Thermal Fuse	Rear	P6-3 (R) or P6-4 (OR) to Red Wire At Terminal Block	Closed Circuit
Bake Element	Front	P6-3 (R) to Red Wire At Terminal Block	25 Ω to 30 Ω
Broil Element	Front	P6-4 (OR) to Red Wire At Terminal Block	45 Ω to 55 Ω
Convection Fan Motor	Rear	P4-8 (OR) to Neutral (W)	8 Ω to 12 Ω
Control Panel Thermal Fuse	Front	L1 (BK) to P7-1 (BK)	Closed Circuit
Latch Switch	Front	P3-2 (BU) to P3-1 (TAN)	Door Unlocked = Open Circuit Door Locked = Closed Circuit

WIRING DIAGRAMS & STRIP CIRCUITS

SCHEMATIC DIAGRAM 1

WIRE HARNESS SCHEMATIC

NOTES:

- When replacing the electronic control, be sure to program the cavity size (see page 6-1).
- Dots indicate connections or splices.
- The circuit is shown in the STANDBY/OFF mode with the oven door closed.

GROUND (CHASSIS)	AC DRIVE MOTOR	SOLENOID
PLUG WITH FEMALE CONNECTOR	RELAY COIL	ENCLOSED THERMISTOR
RECEPTACLE WITH MALE CONNECTOR	RELAY CONTACTS	OPERATED BY DOOR
LIGHT	HEATING ELEMENT	THERMAL FUSE/T.O.D.

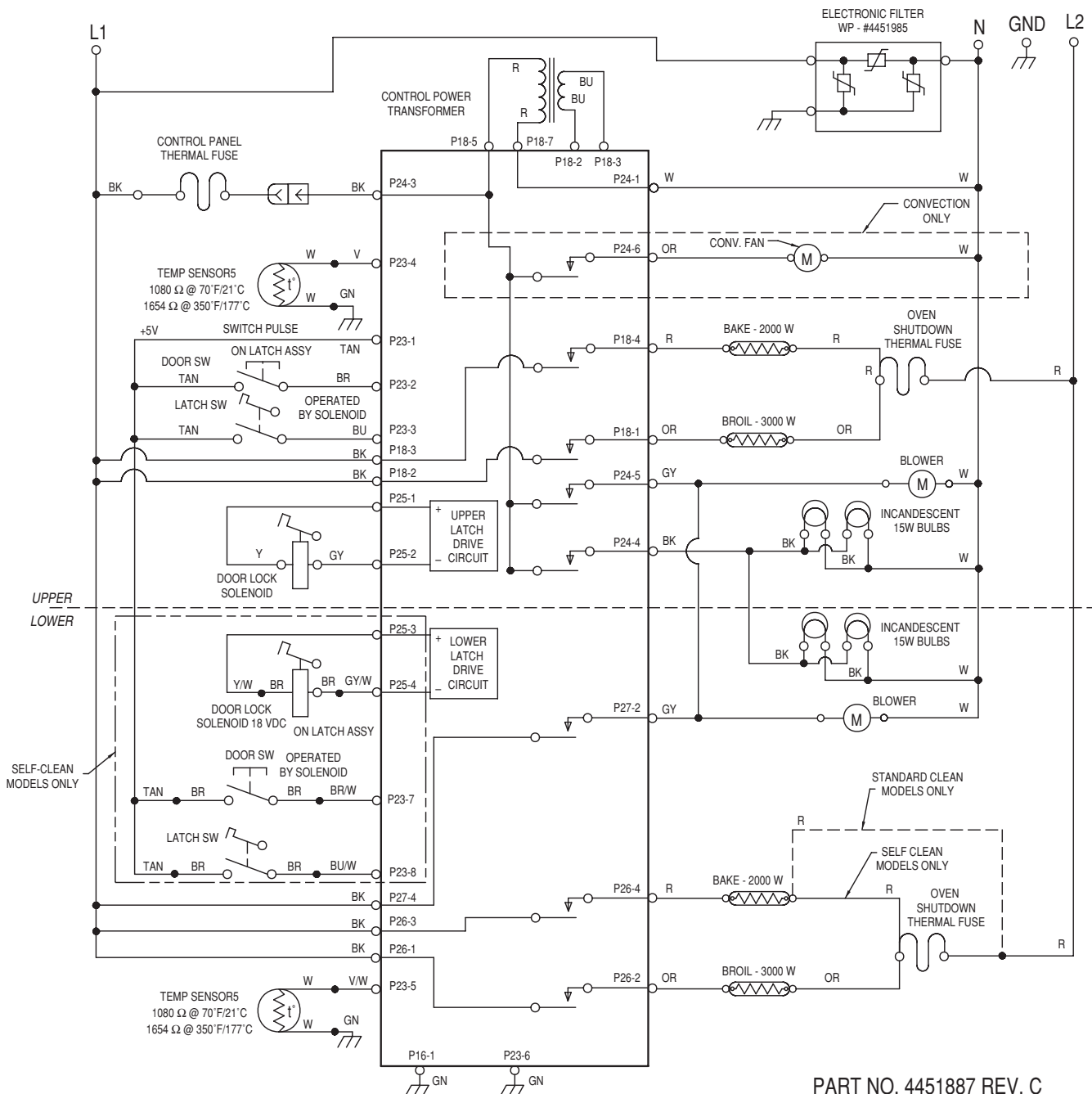

PART NO. 4451887 REV. C

STRIP CIRCUITS

BAKE & PREHEAT BAKE

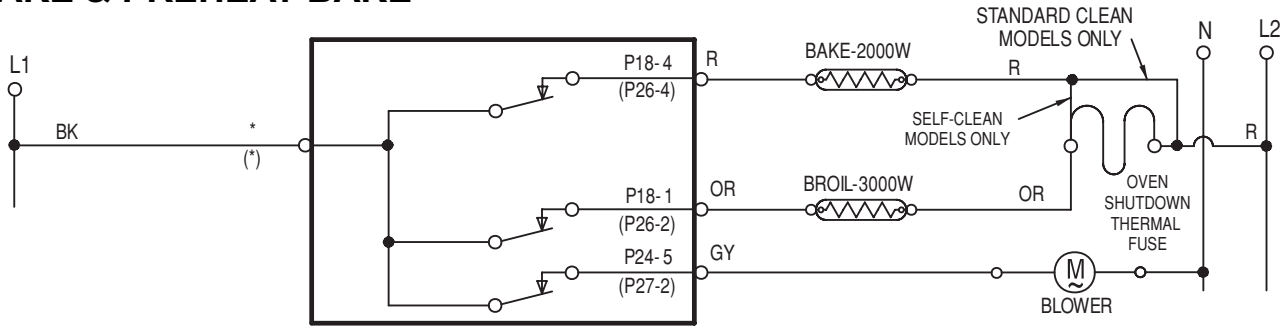

BROIL

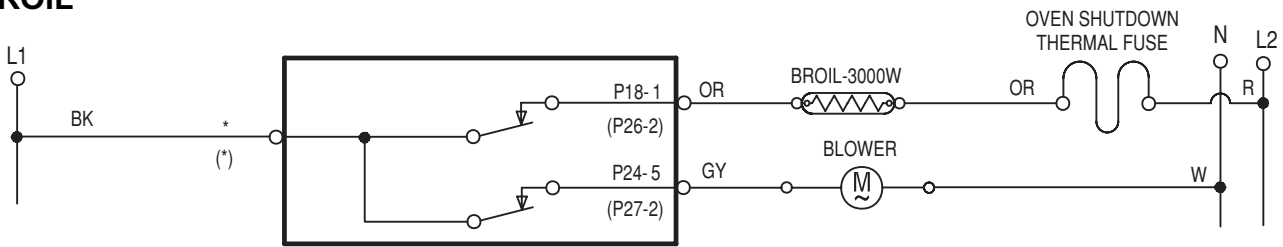

CONVECTION & PREHEAT CONVECTION (CONVECTION MODELS, UPPER OVEN ONLY)

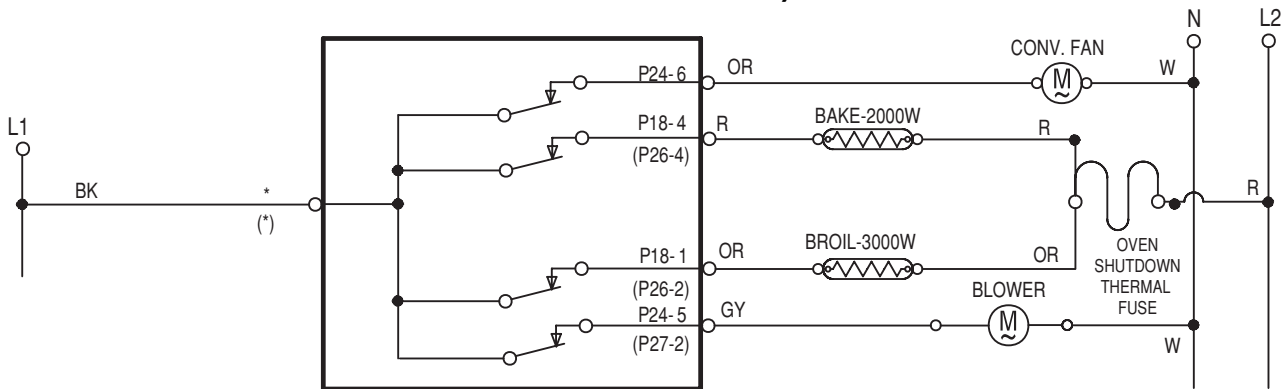

CLEAN & PREHEAT CLEAN (SELF CLEAN MODELS ONLY)

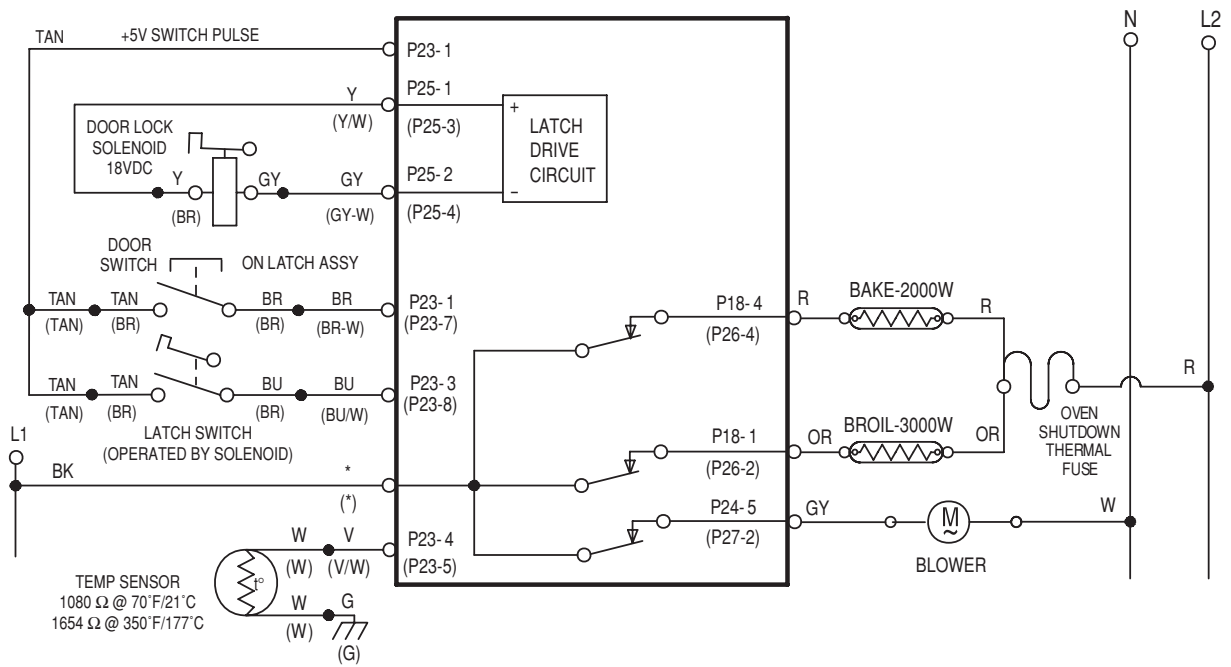

SCHEMATIC DIAGRAM 2

WIRE HARNESS SCHEMATIC

NOTES:

- When replacing the electronic control, be sure to program the cavity size (see page 6-1).
- Dots indicate connections or splices.
- The circuit is shown in the STANDBY/OFF mode with the oven door closed.

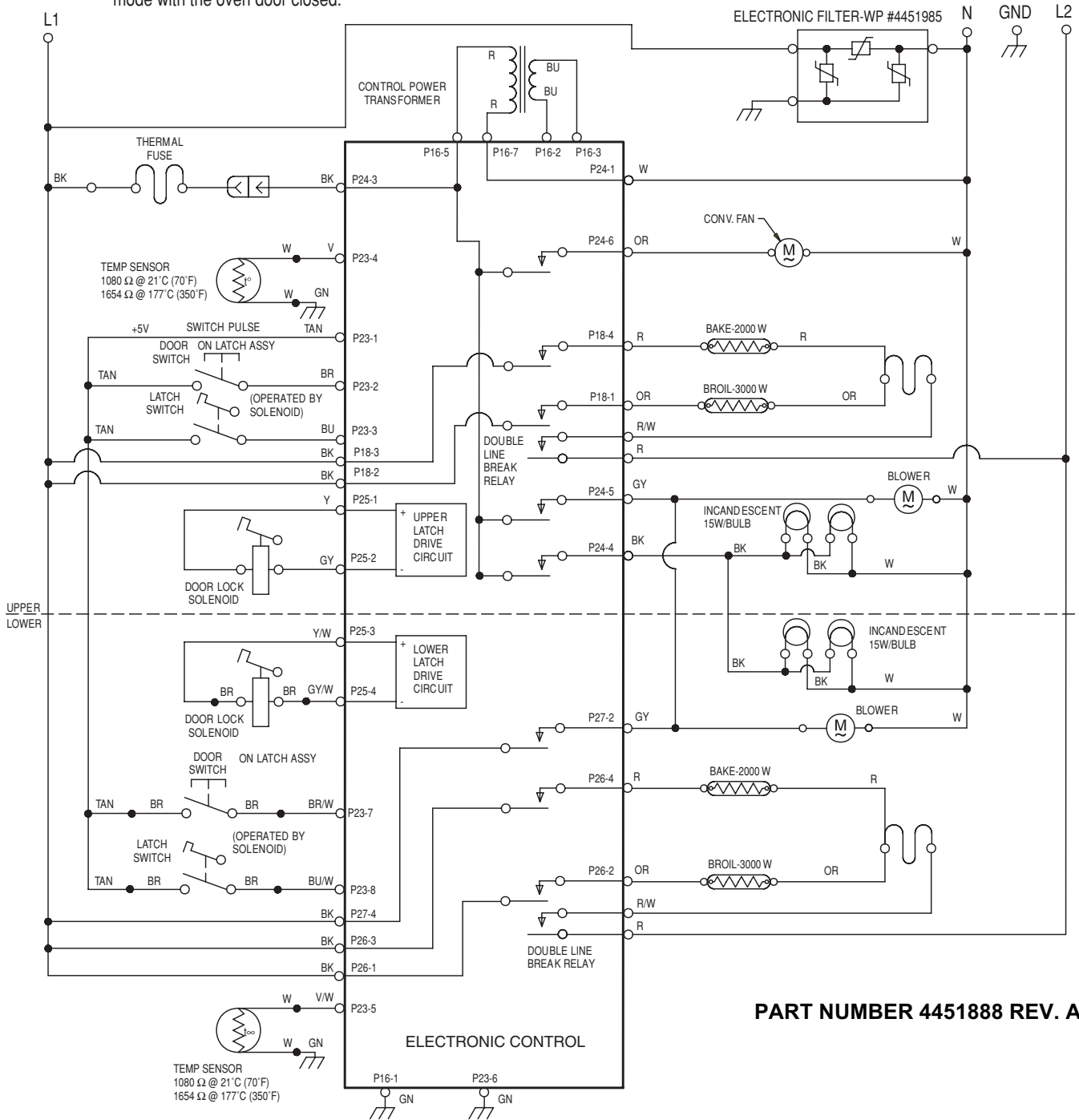
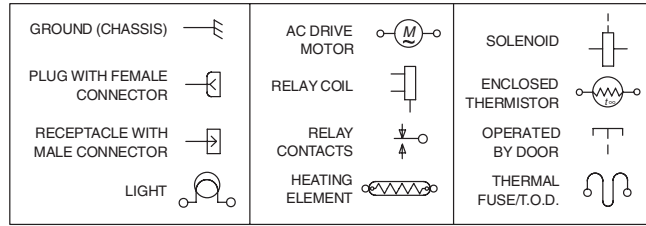

PART NUMBER 4451888 REV. A

STRIP CIRCUITS

BAKE & PREHEAT BAKE

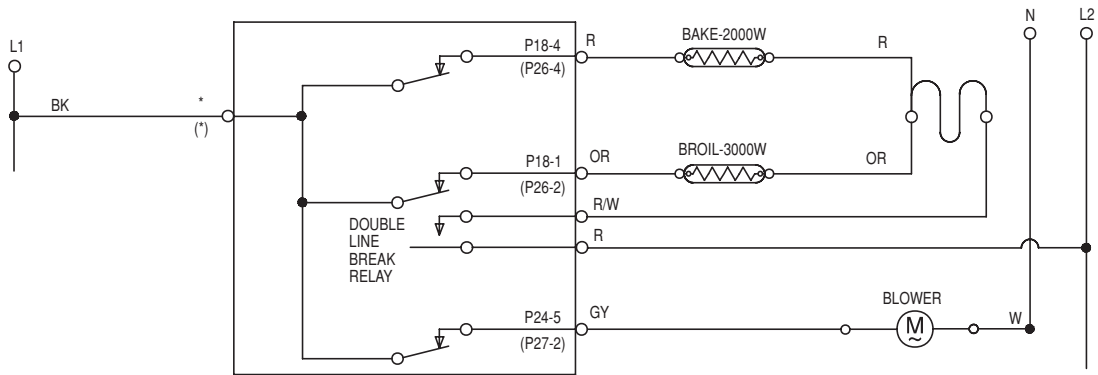

BROIL

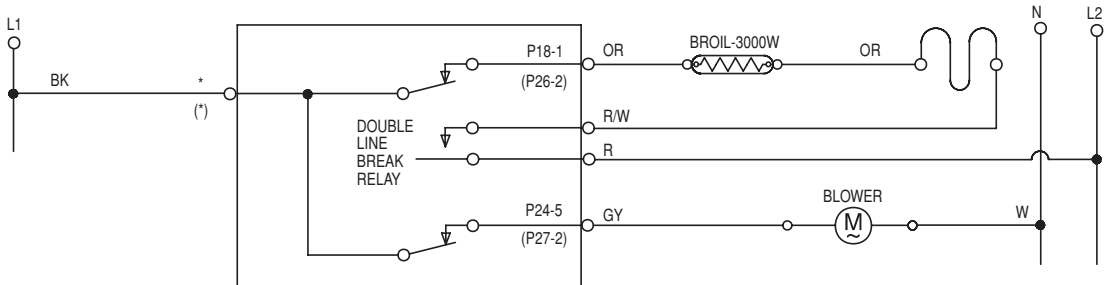

CONVECTION & PREHEAT CONVECTION (CONVECTION MODELS, UPPER OVEN ONLY)

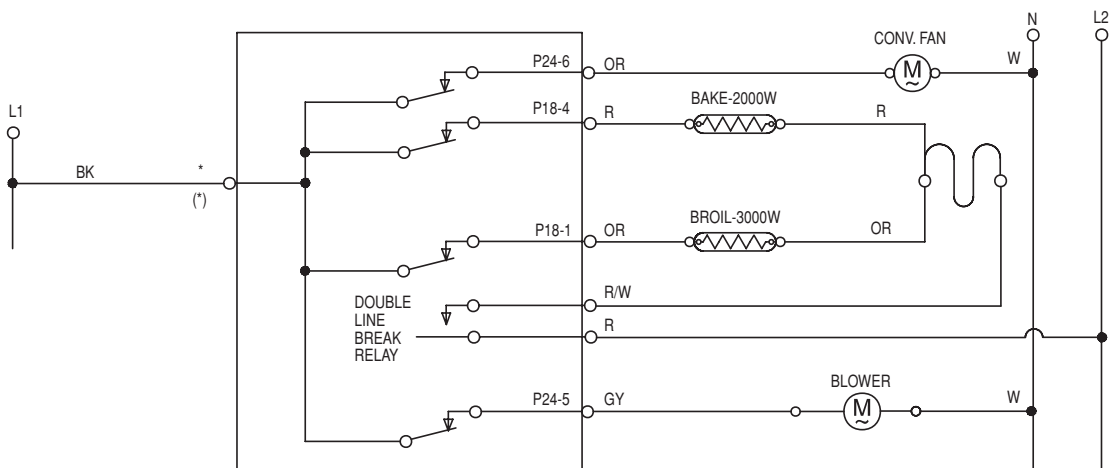

CLEAN & PREHEAT CLEAN (SELF CLEAN MODELS ONLY)

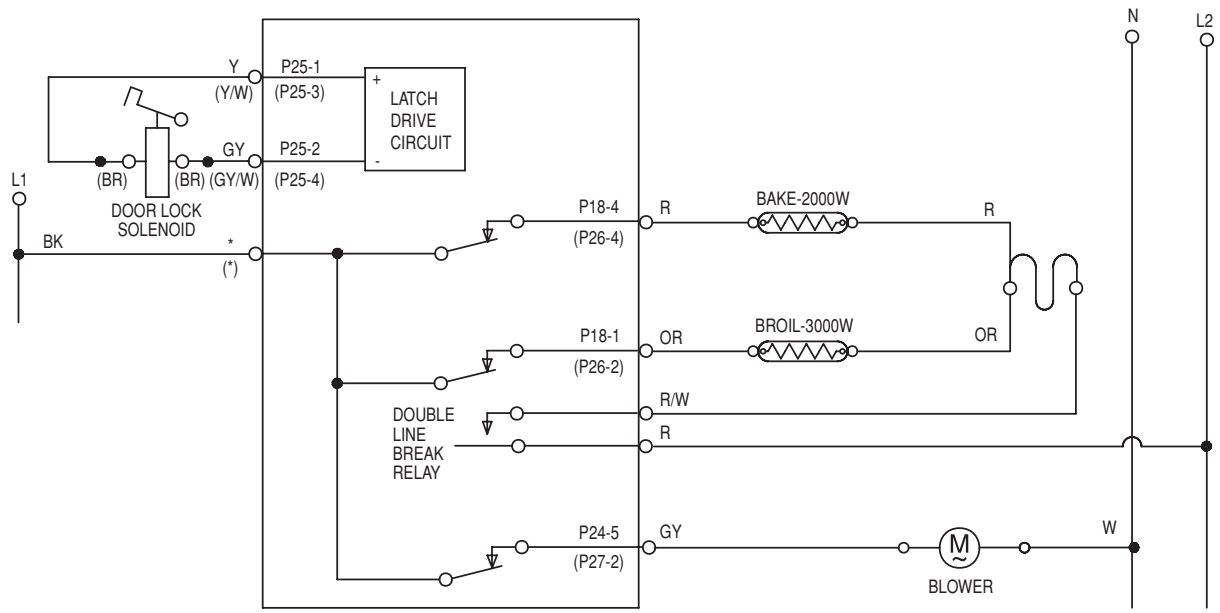

SCHEMATIC DIAGRAM 3

WIRE HARNESS SCHEMATIC

NOTES:

- When replacing the electronic control, be sure to attach the cavity select line to the proper terminal (see "Cavity Size" table below).
- Dots indicate connections or splices.
- The circuit is shown in the STANDBY/OFF mode with the oven door closed.

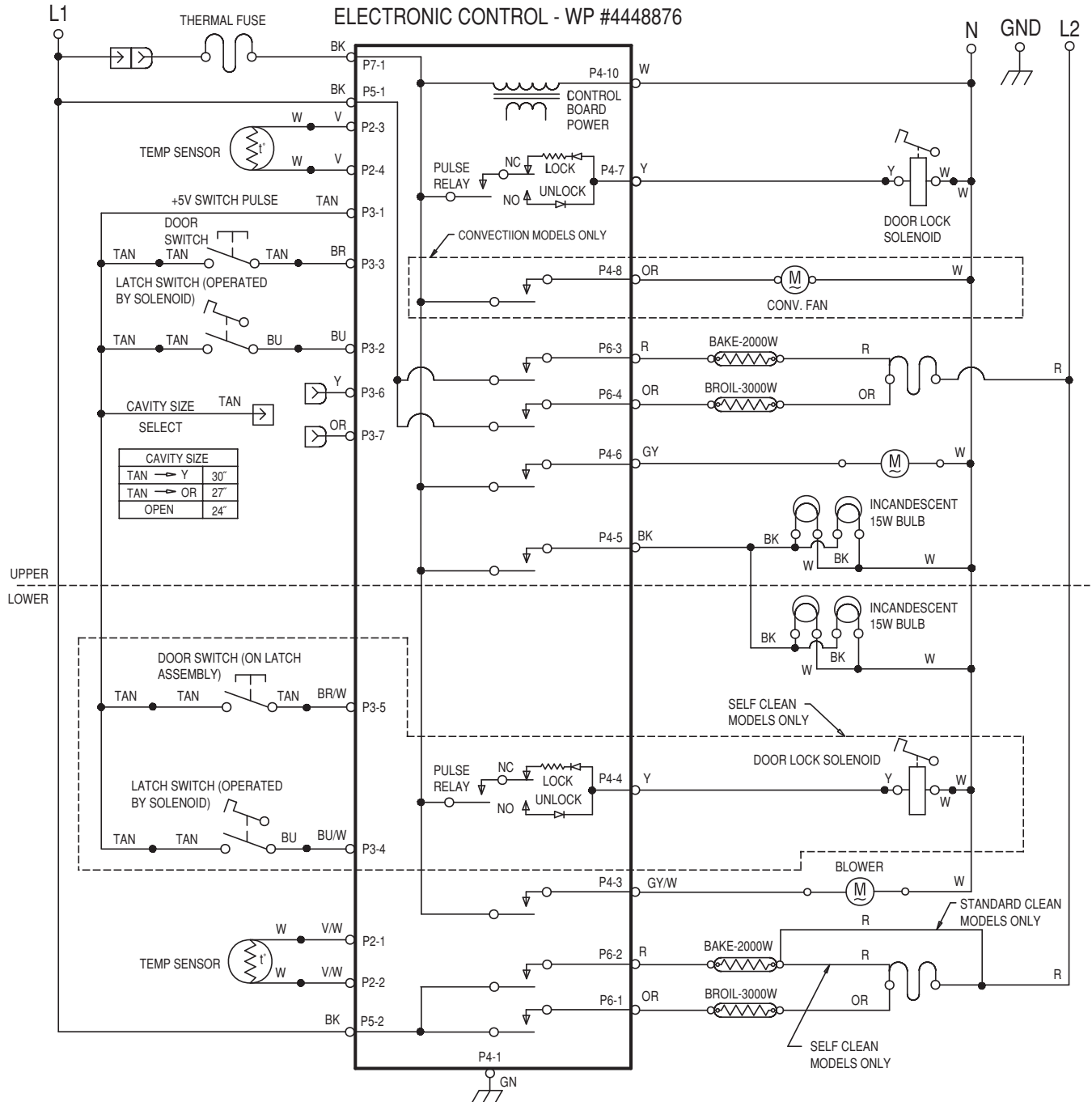
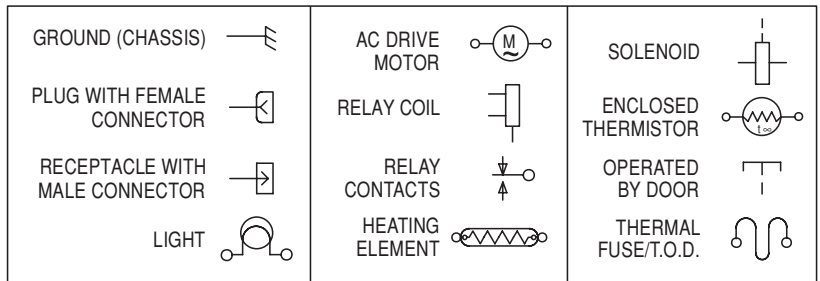

PART NUMBER 4452022 REV. A

STRIP CIRCUITS

BAKE & PREHEAT BAKE

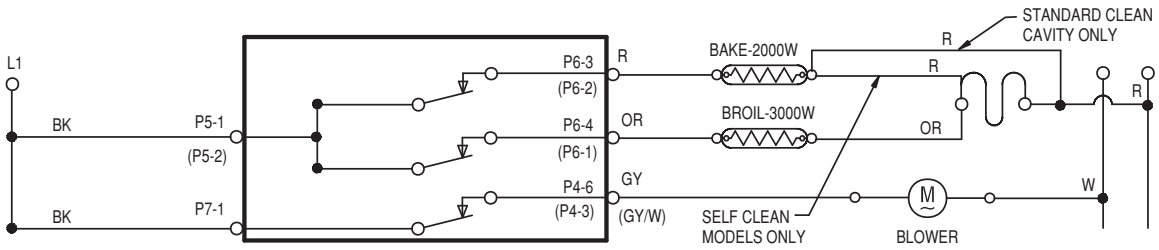

BROIL

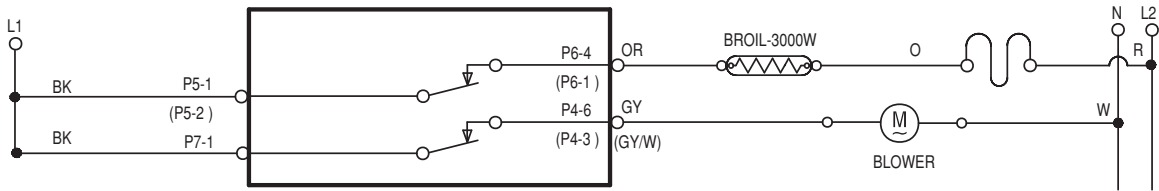

CONVECTION & PREHEAT CONVECTION

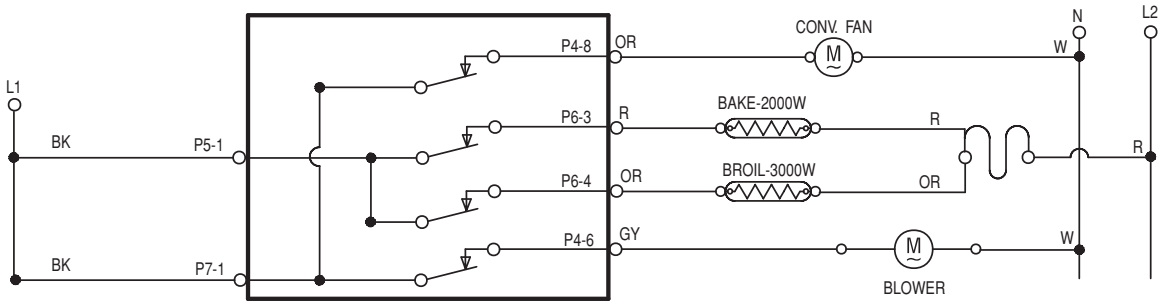

CLEAN (ABOVE 600°F)

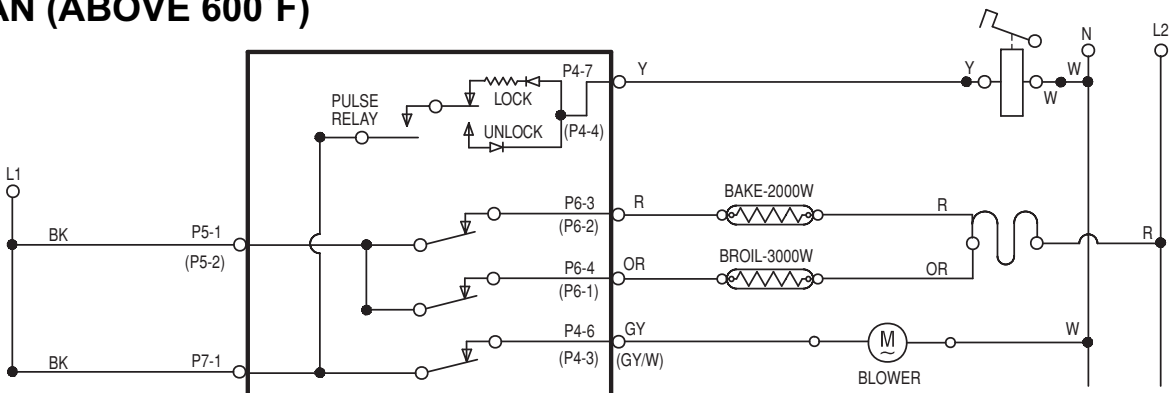

PREHEAT CLEAN (BELOW 600°F)

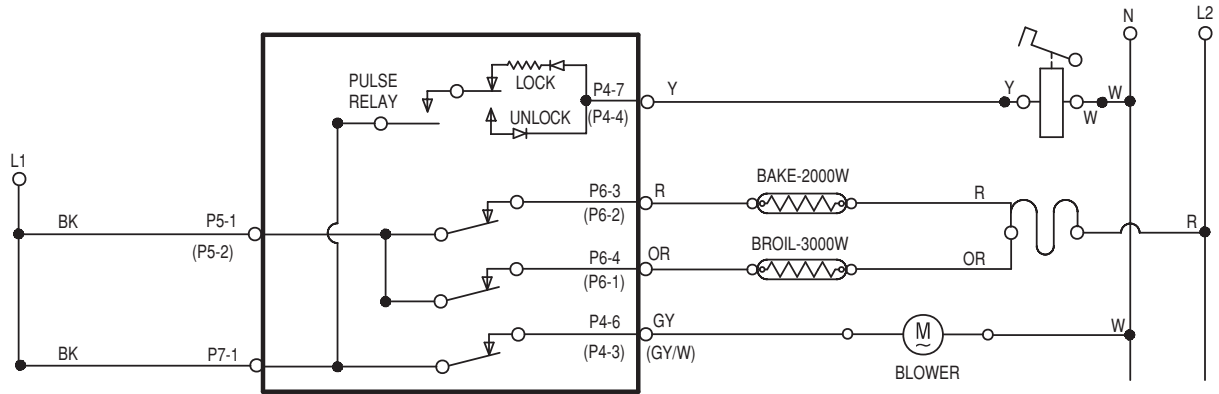

TECH SHEET / MODEL NUMBER USAGE CHARTS

TECH SHEET #	WHERE USED	
4451887	GBD307PD-7	RBD305PD-9
	RBD306PD-12	RBD276PD-9
	RBD305PD-12	RBD306PD-9
	GBD277PD-7	GBD277PD-4
	GBD307PD-6	GBD307PD-4
	RBD306PD-11	RBD276PD-8
	RBD305PD-11	RBD245PD-8
	GBD277PD-6	RBD275PD-8
	RBD276PD-11	RBD305PD-8
	RBD275PD-11	PRD306PD-8
	RBD245PD-11	GBD277PD-3
	GBD307PD-5	GBD207PD-3
	RBD306PD-10	RBD305PD-7
	RBD305PD-10	RBD245PD-7
	GBD277PD-5	RBD275PD-7
	RBD276PD-10	GBD307PD-2
	RBD275PD-10	GBD277PD-2
	RBD245PD-10	RBD306PD-7
	RBD245PD-9	RBD276PD-7
	RBD275PD-9	

TECH SHEET #	WHERE USED	
4452022	RBD276PD-6	RBD275PD-6
	RBD306PD-6	GBD307PD-1
	RBD345PD-6	GBD277PD-1
	RBD305PD-6	

TECH SHEET #	WHERE USED	
4451888	Y GBD307PD-7	Y GBD307PD-4
	Y GBD307PD-6	Y GBD307PD-3
	Y GBD307PD-5	Y GB307PD-2

TECH SHEET #	WHERE USED	
4451991	RBD306PD-7	RBD275PD-12

TECH TIPS

REQUESTING ASSISTANCE OR SERVICE

To avoid unnecessary service calls, please check the “Troubleshooting” section of your Use and Care Guide. It may save you the cost of a service call. If you still need help, follow the instructions below.

1. If the problem is not due to one of the items listed in the “Troubleshooting” section of your Use and Care Guide*:

Call the Whirlpool or Inglis Limited Consumer Assistance Center telephone number. Dial toll-free from anywhere:

In the U.S.A. — Call 1-800-253-1301

In Canada — Call 1-800-461-5681
8:30 a.m. - 6:00 p.m. (EST)

One of our trained consultants can instruct you in how to obtain satisfactory operation from your appliance or, if service is necessary, recommend a qualified service company in your area.

If you prefer, write to:

In the U.S.A. — Whirlpool Brand Home Appliances Consumer Assistance Center

c/o Correspondence Department
2000 North M-63
Benton Harbor, MI 49022-2692

In Canada — Consumer Relations Department

Inglis Limited
1901 Minnesota Court
Mississauga, Ontario L5N 3A7

Please include a daytime phone number in your correspondence.

2a. If you need service in the U.S.A.*:

Whirlpool has a nationwide network of designated Whirlpool service companies. Whirlpool designated service technicians are trained to fulfill the product warranty and

provide after-warranty service, anywhere in the United States. To locate the designated Whirlpool service company in your area, call our Consumer Assistance Center telephone number (see Step 1) or look in your telephone directory Yellow Pages under:

- APPLIANCE-HOUSEHOLD MAJOR, SERVICE & REPAIR (See Whirlpool Appliances or Authorized Whirlpool Service—Example: *XYZ Service Co.*)
- WASHING MACHINES & DRYERS, SERVICE & REPAIR (See Whirlpool Appliances or Authorized Whirlpool Service—Example: *XYZ Service Co.*)

2b. If you need service in Canada*:

Contact “Inglis Limited Appliance Service” from anywhere in Canada at — **1-800-807-6777**.

3. If you need FSP® replacement parts:

FSP® is a registered trademark of Whirlpool Corporation for quality parts. Look for this symbol of quality whenever you need a replacement part for your whirlpool appliance. FSP replacement parts will fit right and work right because they are made to the same exacting specifications used to build every new Whirlpool appliance.

To locate FSP replacement parts in your area, refer to Step 2 or call the Consumer Assistance Center number (see Step 1).

* When asking for help or service: Please provide a detailed description of the problem, your appliance’s complete model and serial numbers, and the purchase date. (See the “A Note to You” section of your Use and Care Guide.) This information will help us respond properly to your request.

WARRANTY

WHIRLPOOL ELECTRIC BUILT-IN OVEN WARRANTY

LENGTH OF WARRANTY:	WHIRLPOOL WILL PAY FOR:	WHIRLPOOL WILL NOT PAY FOR:
<p>ONE-YEAR FULL WARRANTY FROM DATE OF PURCHASE.</p>	<p>FSP® replacement parts and repair labor costs to correct defects in materials or workmanship. Service must be provided by an authorized Whirlpool service company.</p>	<p>A. Service calls to:</p> <ol style="list-style-type: none"> 1. Correct the installation of the built-in oven. 2. Instruct you how to use the built-in oven. 3. Replace house fuses or correct house wiring. 4. Replace owner-accessible light bulbs. <p>B. Repairs when the built-in oven is used in other than normal, single-family household use.</p> <p>C. Pickup and delivery. The built-in oven is designed to be repaired in the home.</p> <p>D. Damage to the built-in oven caused by accident, alteration, misuse, abuse, fire, flood, acts of God, or use of products not approved by Whirlpool.</p> <p>E. Repairs to parts or systems resulting from unauthorized modifications made to the appliance.</p> <p>F. In Canada, travel or transportation expenses for customers who reside in remote areas.</p>

WHIRLPOOL CORPORATION AND INGLIS LIMITED SHALL NOT BE LIABLE FOR INCIDENTAL OR CONSEQUENTIAL DAMAGES. Some states or provinces do not allow the exclusion or limitation of incidental or consequential damages, so this exclusion or limitation may not apply to you. This warranty gives specific legal rights and you may also have other rights which vary from state to state or province to province.

Outside the United States and Canada, a different warranty may apply. For details, please contact your authorized Whirlpool dealer.

If you need service, refer to the “Requesting Assistance or Service” section on the previous page. After checking “Requesting Assistance or Service,” additional help can be found by calling the Whirlpool Consumer Assistance Center telephone number, **1-800-253-1301**, from anywhere in the U.S.A. In Canada, contact your authorized Inglis Limited Appliance Service company, **1-800-807-6777**.

