

# **KitchenAid**

TECHNICAL EDUCATION

## **ELECTRIC BUILT-IN SINGLE OVEN**



**JOB AID 4317323**

# FORWARD

This Job Aid, “KitchenAid Electric Built-In Single Oven,” (Part No. 4317323), provides the technician with information on the installation, operation, and service of the Electric Built-In Single Oven. It is to be used as a training Job Aid and Service Manual. For specific information on the model being serviced, refer to the “Use and Care Guide,” or “Tech Sheet” provided with the oven.

The Wiring Diagrams and Strip Circuits used in this Job Aid are typical and should be used for training purposes only. Always use the Wiring Diagram supplied with the product when servicing the unit.

## GOALS AND OBJECTIVES

The goal of this Job Aid is to provide detailed information that will enable the service technician to properly diagnose malfunctions and repair the KitchenAid Electric Built-In Single Oven.

The objectives of this Job Aid are to:

- Understand and follow proper safety precautions.
- Successfully troubleshoot and diagnose malfunctions.
- Successfully perform necessary repairs.
- Successfully return the oven to its proper operational status.

WHIRLPOOL CORPORATION assumes no responsibility for any repairs made on our products by anyone other than Authorized Service Technicians.

# TABLE OF CONTENTS

Page

<b>GENERAL</b> .....	1-1
Important Safety Information .....	1-1
KitchenAid Model & Serial Number Designations.....	1-2
Model & Serial Number Label And Tech Sheet Locations.....	1-3
Specifications.....	1-4
KitchenAid Single Thermal Convection Oven Warranty .....	1-7
KitchenAid Electric Built-In Oven Warranty .....	1-8
<b>INSTALLATION INFORMATION</b> .....	2-1
Electrical Supply Requirements .....	2-1
Removing & Reinstalling The Oven Door .....	2-3
Oven/Cooktop Combination-Approved Installation .....	2-4
<b>THEORY OF OPERATION</b> .....	2-1
Air Flow .....	3-1
The Oven Shutdown Thermal Fuse .....	3-2
The Oven Door Latch Assembly .....	3-3
How The Self-Clean Cycle Works .....	3-4
<b>COMPONENT ACCESS</b> .....	4-1
Component Locations .....	4-1
Removing The Oven Control/Display Boards And The Touch Panel Assembly.....	4-2
Removing The Power Supply Wiring Terminal Block And The Blower Motor .....	4-4
Removing The Oven Light Transformer & The Control Power Transformer .....	4-6
Removing The Oven Door Latch Assembly.....	4-7
Removing An Oven Halogen Light And The Oven Temperature Sensor .....	4-8
Removing The Broil Element .....	4-10
Removing The Meat Probe Jack .....	4-11
Removing The Hidden Bake Element.....	4-12
Removing The Convection Bake Element And The Fan Motor Assembly .....	4-14
Removing The Oven Shutdown Thermal Fuse.....	4-16
Removing The Oven Door Glass, Hinges, & Handle .....	4-17
Removing The Oven Door Gasket.....	4-19
<b>COMPONENT TESTING</b> .....	5-1
Blower Motor .....	5-1
Oven Temperature Sensor .....	5-1
Convection Bake Element .....	5-2
Convection Fan Motor .....	5-2
Broil Element .....	5-3
Bake Element .....	5-3
Oven Door Latch Assembly .....	5-4
Oven Shutdown Thermal Fuse .....	5-4
Oven Light & Control Power Transformers .....	5-5

	<b>Page</b>
<b>DIAGNOSIS &amp; TROUBLESHOOTING</b> .....	6-1
Diagnostics .....	6-1
Fahrenheit To Celsius Conversion .....	6-1
Programming The Cavity Size .....	6-1
Electrostatic Discharge Sensitive Electronics .....	6-1
Failure/Error Display Codes .....	6-2
Control Panel Test Locations .....	6-3
Relay Logic Chart .....	6-3
<b>WIRING DIAGRAMS &amp; STRIP CIRCUITS</b> .....	7-1
Model Number/Tech Sheet Use .....	7-1
Schematic Diagram .....	7-2
Strip Circuits .....	7-3

# GENERAL

## IMPORTANT SAFETY INFORMATION

**Your safety and the safety of others is very important.**

Important safety messages have been provided in this Job Aid. Always read and obey all safety messages.



This is the safety alert symbol. This symbol alerts you to hazards that can kill or hurt you and others.

All safety messages will be preceded by the safety alert symbol and the word **“WARNING.”**

All safety messages will identify the hazard, tell you how to reduce the chance of injury, and tell you what can happen if the instructions are not followed.

**! WARNING**

### **ELECTRICAL SHOCK HAZARD**

Disconnect power before servicing.

Replace all panels before operating.

Failure to do so could result in death or electrical shock.

### **ELECTROSTATIC DISCHARGE (ESD) SENSITIVE ELECTRONICS**

ESD problems are present everywhere. ESD may damage or weaken the electronic control assembly. The new control assembly may appear to work well after repair is finished, but failure may occur at a later date due to ESD stress.

- Use an antistatic wrist strap. Connect the wrist strap to a green ground connection point or unpainted metal in the appliance; or touch your finger repeatedly to a green ground connection point or unpainted metal in the appliance.
- Before removing the part from its package, touch the antistatic bag to a green ground connection point or unpainted metal in the appliance.
- Avoid touching electronic parts or terminal contacts. Handle the electronic control assembly by the edges only.
- When repackaging the failed electronic control assembly in an antistatic bag, observe the above instructions.

# KITCHENAID MODEL & SERIAL NUMBER DESIGNATIONS

## MODEL NUMBER

<b>MODEL NUMBER</b>		<b>K</b>	<b>EB</b>	<b>S</b>	<b>10</b>	<b>7</b>	<b>D</b>	<b>SS</b>	<b>8</b>
<b>INTERNATIONAL SALES IND. OR MARKETING CHANNEL IF PRESENT</b>									
<b>PRODUCT GROUP</b> K = KITCHENAID BRAND									
<b>PRODUCT IDENTIFICATION</b> EB = ELECTRIC BUILT-IN OVEN EH = ELECTRIC BUILT-IN HI SPEED COMBO EM = ELECTRIC BUILT-IN MICRO COMBO EW = ELECTRIC WARMING OVEN GB = GAS BUILT-IN OVEN GM = GAS BUILT-IN MICRO COMBO OVEN									
<b>MERCHANDISING SCHEME</b> C = FLUSH LOOK D = DRAWER I = IMPERIAL N = INTERNATIONAL COLLECTION EUROPEAN S = SUPERBA									
<b>CAPACITY / SIZE / SERIES / CONFIGURATION</b> 1ST POSITION                      2ND POSITION 1 = SINGLE OVEN                      4 = 24" WIDE 2 = DOUBLE OVEN                      6 = 36" WIDE 3 = COMBO OVEN                      7 = 27" WIDE 4 = OVEN W/DRAWER                      0 = 30" WIDE 5 = MINI OVEN 6 = COMBO W/MINI OVEN									
<b>FEATURES</b> 0 = STANDARD FEATURES 1 = STANDARD FEATURES / ELECTRIC CLOCK 5 = DELUXE FEATURES 6 = DELUXE FEATURES / ELECTRIC CLOCK 7 = DELUXE FEATURES / THERMAL CONVECTION 8 = DOUBLE THERMAL CONVECTION 9 = MULTIMODE									
<b>YEAR OF INTRODUCTION</b> D = 1995, G = 1998, H = 1999, J = 2000									
<b>COLOR CODE</b> AL = ALMOND, BL = BLACK, BT = BISCUIT, WH = WHITE, SS = BRUSHED STAINLESS STEEL									
<b>ENGINEERING CHANGE (0, 1, 2, ETC.)</b>									

## SERIAL NUMBER

<b>SERIAL NUMBER</b>	<b>X</b>	<b>K</b>	<b>03</b>	<b>01006</b>
<b>MANUFACTURING SITE</b> X = OXFORD				
<b>YEAR OF PRODUCTION</b> K = 2000, L = 2001, M = 2002				
<b>WEEK OF PRODUCTION</b> 3RD WEEK				
<b>PRODUCT SEQUENCE NUMBER</b>				

# MODEL & SERIAL NUMBER LABEL AND TECH SHEET LOCATIONS

The Model/Serial Number label and Tech Sheet locations are shown below.



Tech Sheet Location  
(Below Top Front Cover)



# SPECIFICATIONS

Model Number	KEBI141D	KEBS147D	KEBS177D
Colors Available	BL, WH	BL, WH	SS
Model Description	Single Built-In Oven	Single Built-In Oven	Single Built-In Oven
Size-Configuration	24"	24"	27"
<b>Dimensions/Specifications</b>			
Overall Height (in)	28 7/8"	28 7/8"	28 7/8"
Overall Width (in)	23 3/4"	23 3/4"	26 3/4"
Overall Depth Inc Hrdwr/Hndl (in)	25 1/8"	25 1/8"	25 1/8"
Depth W/O Handle (in)	23 7/8"	23 7/8"	23 7/8"
Cutout Dimensions			
Cutout Height (in) (Measure Or Min/Max)	27 3/4"	27 3/4"	27 3/4"
Cutout Width (in) (Measure Or Min/Max)	22 1/2"	22 1/2"	25 1/2"
Cutout Depth (in) (Measure Or Min/Max)	23 1/4"	23 1/4"	23 1/4"
Other Dimensions			
Conduit Size (in) (Length/Diameter)	48"; 1/2"	48"; 1/2"	48"; 1/2"
Net Weight (lbs)	115	121	126
Shipping Weight (lbs)	123	129	134
Total Connected Load in kW			
240 Volts	4.9 kw	4.9 kw	4.9 kw
208 Volts	3.7 kw	3.7 kw	3.7 kw
240/120V AC			
Circuit Amps	30 AMP	30 AMP	30 AMP
<b>Exterior</b>			
Oven Front Frame	Porcelain	Porcelain	Porcelain
Oven Control Type	Electronic	Electronic	Electronic
Bake	Standard	Standard	Standard
Maxi Broil	Yes	Yes	Yes
Econo Broil	Yes	Yes	Yes
Convection			3rd Element
Child Lock Out	Yes	Yes	Yes
<b>Interior</b>			
Main Oven			
Cooking System		True Convection	True Convection
Cleaning System	Self Cleaning	Self Cleaning	Self Cleaning
Auto Self Clean Latch	Yes	Yes	Yes
Main Oven Liner Finish	Porcelain	Porcelain	Porcelain
Main Oven Volume (cu ft)	3.27	3.09	3.58
Main Oven Height (in)	16"	16"	16"
Main Oven Width (in)	19"	19"	22"
Main Oven Depth (in)	18 1/2"	18 1/2"	18 1/2"
Main Electric Oven			
Main Hidden Bake Element	Yes	Yes	Yes
Main Electric Element Output			
Main Oven Bake (w@240/208v)	2000W/1500W	2000W/1500W	2000W/1500W
Main Oven Broil Inner Element (w@240/208v)	1667W/1250W	1667W/1250W	1667W/1250W
Main Oven Broil Outer Element (w@240/208)	1000W/750W	1000W/750W	1000W/750W
Main Oven Convection (w@240/208v)		1600W/1200W	1600W/1200W
<b>Miscellaneous</b>			
Cookbook Part/Comment		4449066	4449066
Installation Instructions Part/Comment	4448970	4448970	4450411
Service Manual Part/Comment	4317323	4317323	4317323
Tech Sheet Part/Comment	4451876	4451876	4451876
Use & Care Guide Oven Part/Comment	4448999	4449000	4450571
Other			
Agency Approvals	UL, CSA	UL, CSA	UL, CSA
Installation Hardware	Yes	Yes	Yes
Residential Use Only	Yes	Yes	Yes
Under Counter Capability	Yes	Yes	Yes
Warranty			
Full (Months)	12	12	12
Extended			
Electronic Controls (Months)	60	60	60
Electrical Elements (Months)	60	60	60
Porcelain Liner/Door (Months)	120	120	120



Model Number	KEBS107D	KEBC177H
Colors Available	SS	BT, BL, WH
Model Description	Single Built-In Oven	Single Built-In Oven
Size-Configuration	30"	27"
<b>Dimensions/Specifications</b>		
Overall Height (in)	28 7/8"	28 7/8"
Overall Width (in)	29 3/4"	26 3/4"
Overall Depth Inc Hrdwr/Hndl (in)	25 1/8"	25 1/8"
Depth W/O Handle (in)	23 7/8"	23 7/8"
Cutout Dimensions		
Cutout Height (in) (Measure Or Min/Max)	27 3/4"	27 3/4"
Cutout Width (in) (Measure Or Min/Max)	28 1/2"	25 1/2"
Cutout Depth (in) (Measure Or Min/Max)	23 1/4"	23 1/4"
Other Dimensions		
Conduit Size (in) (Length/Diameter)	48"; 1/2"	48"; 1/2"
Net Weight (lbs)	126	126
Shipping Weight (lbs)	139	134
Total Connected Load in kW		
240 Volts	4.9 kw	4.9 kw
208 Volts	3.7 kw	3.7 kw
240/120V AC		
Circuit Amps	30 AMP	30 AMP
<b>Exterior</b>		
Oven Front Frame	Porcelain	Porcelain
Oven Control Type	Electronic	Electronic
Bake	Standard	Standard
Maxi Broil	Yes	Yes
Econo Broil	Yes	Yes
Convection	3rd Element	3rd Element
Child Lock Out	Yes	Yes
<b>Interior</b>		
Main Oven		
Cooking System	True Convection	True Convection
Cleaning System	Self Cleaning	Self Cleaning
Auto Self Clean Latch	Yes	Yes
Main Oven Liner Finish	Porcelain	Porcelain
Main Oven Volume (cu ft)	4.24	3.58
Main Oven Height (in)	16"	16"
Main Oven Width (in)	25"	22"
Main Oven Depth (in)	18 1/2"	18 1/2"
Main Electric Oven		
Main Hidden Bake Element	Yes	Yes
Main Electric Element Output		
Main Oven Bake (w@240/208v)	2000W/1500W	2000W/1500W
Main Oven Broil Inner Element (w@240/208v)	1667W/1250W	1667W/1250W
Main Oven Broil Outer Element (w@240/208)	1000W/750W	1000W/750W
Main Oven Convection (w@240/208v)	1600W/1200W	1600W/1200W
<b>Miscellaneous</b>		
Cookbook Part/Comment	4449066	4449066
Installation Instructions Part/Comment	4450411	4448970
Service Manual Part/Comment	4317323	4317323
Tech Sheet Part/Comment	4451876	4451876
Use & Care Guide Oven Part/Comment	4450571	4449000
Other		
Agency Approvals	UL, CSA	UL, CSA
Installation Hardware	Yes	Yes
Residential Use Only	Yes	Yes
Under Counter Capability	Yes	Yes
Warranty		
Full (Months)	12	12
Extended		
Electronic Controls (Months)	60	60
Electrical Elements (Months)	60	60
Porcelain Liner/Door (Months)	120	120

Model Number	KEBC107H	KEBC107H
Colors Available	BT, WH	BL
Model Description	Single Built-In Oven	Single Built-In Oven
Size-Configuration	30"	30"
<b>Dimensions/Specifications</b>		
Overall Height (in)	28 7/8"	28 7/8"
Overall Width (in)	29 3/4"	29 3/4"
Overall Depth Inc Hrdwr/Hndl (in)	25 1/8"	25 1/8"
Depth W/O Handle (in)	23 7/8"	23 7/8"
Cutout Dimensions		
Cutout Height (in) (Measure Or Min/Max)	27 3/4"	27 3/4"
Cutout Width (in) (Measure Or Min/Max)	28 1/2"	28 1/2"
Cutout Depth (in) (Measure Or Min/Max)	23 1/4"	23 1/4"
Other Dimensions		
Conduit Size (in) (Length/Diameter)	48"; 1/2"	48"; 1/2"
Net Weight (lbs)	131	131
Shipping Weight (lbs)	139	139
Total Connected Load in kW		
240 Volts	4.9 kw	4.9 kw
208 Volts	3.7 kw	3.7 kw
240/120V AC		
Circuit Amps	30 AMP	30 AMP
<b>Exterior</b>		
Oven Front Frame	Porcelain	Porcelain
Oven Control Type	Electronic	Electronic
Bake	Standard	Standard
Maxi Broil	Yes	Yes
Econo Broil	Yes	Yes
Convection	3rd Element	3rd Element
Child Lock Out	Yes	Yes
<b>Interior</b>		
Main Oven		
Cooking System	True Convection	True Convection
Cleaning System	Self Cleaning	Self Cleaning
Auto Self Clean Latch	Yes	Yes
Main Oven Liner Finish	Porcelain	Porcelain
Main Oven Volume (cu ft)	4.07	4.07
Main Oven Height (in)	16"	16"
Main Oven Width (in)	25"	25"
Main Oven Depth (in)	18 1/2"	18 1/2"
Main Electric Oven		
Main Hidden Bake Element	Yes	Yes
Main Electric Element Output		
Main Oven Bake (w@240/208v)	2000W/1500W	2000W/1500W
Main Oven Broil Inner Element (w@240/208v)	1667W/1250W	1667W/1250W
Main Oven Broil Outer Element (w@240/208)	1000W/750W	1000W/750W
Main Oven Convection (w@240/208v)	1600W/1200W	1600W/1200W
<b>Miscellaneous</b>		
Cookbook Part/Comment	4449066	4449066
Installation Instructions Part/Comment	4448970	4448970
Service Manual Part/Comment	4317323	4317323
Tech Sheet Part/Comment	4451876	4451876
Use & Care Guide Oven Part/Comment	4449000	4449000
Other		
Agency Approvals	UL, CSA	UL, CSA
Installation Hardware	Yes	Yes
Residential Use Only	Yes	Yes
Under Counter Capability	Yes	Yes
Warranty		
Full (Months)	12	12
Extended		
Electronic Controls (Months)	60	60
Electrical Elements (Months)	60	60
Porcelain Liner/Door (Months)	120	120

# KITCHENAID SINGLE THERMAL CONVECTION OVEN WARRANTY

LENGTH OF WARRANTY	KITCHENAID WILL PAY FOR:
<b>FULL ONE YEAR WARRANTY</b> From Date of Purchase.	Replacement parts and repair labor to correct defects in materials or workmanship. Service must be provided by an authorized KitchenAid service company.
<b>FIVE YEAR LIMITED WARRANTY</b> 2nd through 5th Year	Parts only. Electric element, electronic control, & convection element.
<b>TEN YEAR LIMITED WARRANTY</b> 2nd through 10th Year	Parts only. Oven cavity and inner door.
<p><b>KITCHENAID WILL NOT PAY FOR:</b></p> <p>A. Service calls to:</p> <ol style="list-style-type: none"> <li>1. Correct the installation of the oven.</li> <li>2. Instruct you how to use the oven.</li> <li>3. Replace house fuses or correct house wiring or plumbing.</li> <li>4. Replace owner-accessible light bulbs.</li> </ol> <p>B. Repairs when oven is used in other than normal, single family household use.</p> <p>C. Pickup and delivery. Your oven is designed to be repaired in the home.</p> <p>D. Damage to your oven caused by accident, misuse, fire, flood, acts of God, or use of products not approved by Whirlpool.</p> <p>E. Repairs to parts or systems caused by unauthorized modifications made to the appliance.</p>	

**KITCHENAID SHALL NOT BE LIABLE FOR INCIDENTAL OR CONSEQUENTIAL DAMAGES.** Some states do not allow the exclusion or limitation of incidental or consequential damages, so this exclusion or limitation may not apply to you. This warranty gives you special legal rights, and you may also have other rights which vary from state-to-state.

Outside the United States, a different warranty may apply. For details, please contact your authorized Whirlpool or KitchenAid distributor or military exchange.

If you need service first see the "Troubleshooting" section of the Use and Care Guide. After checking "Troubleshooting," additional help can be found by checking the "Requesting Assistance or Service" section, or by calling our Consumer Assistance Center telephone number from anywhere in the U.S.A.

KitchenAid: **1-800-422-1230** Benton Harbor, Michigan 49022  
Canadian Residents call: **1-800-461-5681**

# KITCHENAID ELECTRIC BUILT-IN OVEN WARRANTY

LENGTH OF WARRANTY:	KITCHENAID WILL PAY FOR:	KITCHENAID WILL NOT PAY FOR:
<b>ONE-YEAR FULL WARRANTY</b> From Date of Purchase.	Replacement parts and repair labor costs to correct defects in materials or workmanship. Service must be provided by a KitchenAid designated servicing company.	A. Service calls to: <ol style="list-style-type: none"> <li>1. Correct the installation of the oven.</li> <li>2. Instruct you how to use the oven.</li> <li>3. Replace house fuses or correct house wiring.</li> </ol> B. Repairs when oven is used in other than normal home use. C. Damage resulting from accident, alteration, misuse, abuse, acts of God, improper installation, or installation not in accordance with local electrical codes. D. Any labor costs during the limited warranties. E. Replacement parts or repair labor costs for units operated outside the United States and Canada. F. Pickup and delivery. This product is designed to be repaired in the home. G. Repairs to parts or systems resulting from unauthorized modifications made to the appliance. H. In Canada, travel or transportation expenses for customers who reside in remote areas.
<b>SECOND-THROUGH FIFTH-YEAR LIMITED WARRANTY</b> From Date of Purchase.	Replacement parts for any oven electric element to correct defects in materials or workmanship. Replacement parts for solid state touch control system to correct defects in materials or workmanship.	
<b>SECOND-THROUGH TENTH-YEAR LIMITED WARRANTY</b> From Date of Purchase.	Replacement parts for the porcelain oven cavity/inner door if the part rusts through due to defects in materials or workmanship.	

**KITCHENAID AND KITCHENAID CANADA DO NOT ASSUME ANY RESPONSIBILITY FOR INCIDENTAL OR CONSEQUENTIAL DAMAGES.** Some states or provinces do not allow the exclusion or limitation of incidental or consequential damages, so this exclusion or limitation may not apply to you. This warranty gives specific legal rights and you may also have other rights which vary from state to state or province to province.

**Outside the United States and Canada, a different warranty may apply. For details, please contact your authorized KitchenAid dealer.**

If you need assistance or service, first see the "Diagnosis & Troubleshooting" section of this book. After checking "Diagnosis & Troubleshooting," additional help can be found by checking the "Requesting Assistance or Service" section in the Use And Care Guide. In the U.S.A., call our Consumer Assistance Center at: **1-800-422-1230**. In Canada, call KitchenAid Canada at: **1-800-807-6777**.

# INSTALLATION INFORMATION

## ELECTRICAL SUPPLY REQUIREMENTS

### **WARNING**

#### **ELECTRICAL SHOCK HAZARD**

- An electrical ground is required on this appliance.
- Do not use an extension cord with this appliance.
- If a cold water pipe is interrupted by plastic, nonmetallic gaskets, or other insulating materials, do not use for grounding.
- Do not ground to a gas pipe.
- Do not use a fuse in the neutral or grounding circuit. It could result in an electrical shock.
- Check with a qualified electrician if you are in doubt as to whether the appliance is properly grounded.

Failure to follow these instructions could result in death or serious injury.

#### **GENERAL**

If codes permit, and a separate grounding wire is used, it is recommended that a qualified electrician determine that the grounding path and wire gauge are in accordance with local codes.

The following information applies to the built-in electric wall oven wiring:

- The oven must be connected to the proper electrical voltage and frequency as specified on the model/serial rating plate (located on the oven frame).
- Models rated from 7.3 to 9.6 kW at 240-volts, (6.5 to 7.2 kW at 208-volts), require a separate 40-ampere circuit. Models rated at 7.2 kW and below at 240-volts, (5.4 kW and below at 208-volts), require a separate 30-ampere circuit.

- The oven must be connected with copper wire only.
- Wire sizes and connections must conform to the requirements of the National Electrical Code, ANSI/NFPA 70—latest edition\*, and all local codes and ordinances. Wire sizes and connections must conform with the rating of the appliance. Copies of the standards listed above may be obtained from:

**\* National Fire Protection Association  
Batterymarch Park  
Quincy, Massachusetts 02269**

- The oven should be connected directly to a time delay fuse or circuit breaker through flexible, armored, or nonmetallic sheathed, copper cable. The flexible, armored cable that extends from the appliance should be connected directly to the junction box.
- Fuse both sides of the line.
- Locate the junction box to allow as much slack as possible between the junction box and the appliance so that the appliance can be moved if servicing is ever necessary. Do not cut the conduit.
- A U.L.-listed conduit connector must be provided at the junction box.
- Wiring diagrams are located in Section 7 of this Job Aid.
- A Tech Sheet is located below the top access cover on all models.

## ELECTRICAL WIRING

# ! WARNING

### ELECTRICAL SHOCK HAZARD

- An electrical ground is required on this appliance.
- Do not connect to the electrical supply until the appliance is permanently grounded.
- Turn off power to the junction box before making the electrical connections.
- Connect the appliance to a grounded, metallic, permanent wiring system.

Failure to follow these instructions could result in death or serious injury.

1. Insert the end of the flexible conduit through the cabinet opening to the junction box inlet.
2. Disconnect the power going to the junction box.
3. Open the junction box cover and connect the flexible conduit to the U.L.-listed conduit connector.
4. Connect the ends of the black wires together with twist-on connectors (see the illustration below).
5. Connect the ends of the red wires together with twist-on connectors.

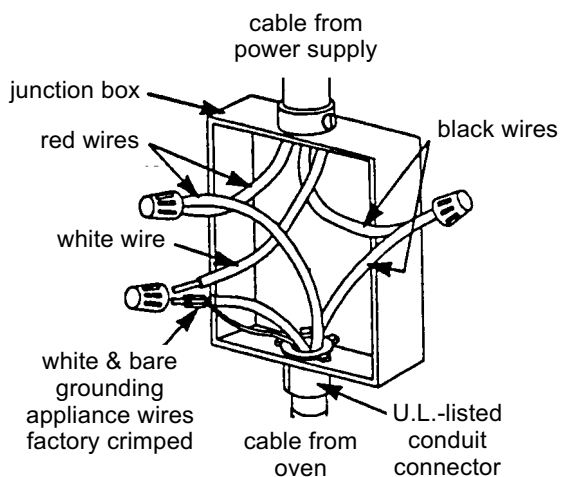

***Crimped Grounding Conductors To White (Neutral) Wire***

**If local codes DO permit** connecting the cabinet-grounding conductor to a neutral junction box wire, perform steps 6 and 7.

**If local codes DO NOT permit** connecting the cabinet-grounding conductor to a neutral junction box wire, or if you are connecting the appliance to a 4-wire electrical system, perform steps 8 through 11.

6. Connect the factory-crimped bare and white electrical wires coming from the appliance conduit cable to the white (neutral) wire inside the junction box (see the illustration below).
7. Replace the junction box cover.
8. Separate the factory-crimped bare and white electrical wires coming from the appliance conduit cable.
9. Connect the white appliance wire to the white (neutral) wire inside the junction box.
10. Connect the bare grounding wire from the appliance to a grounded wire inside the junction box. **IMPORTANT: Do not connect the bare grounding wire to the white (neutral) wire in the junction box.**
11. Replace the junction box cover.

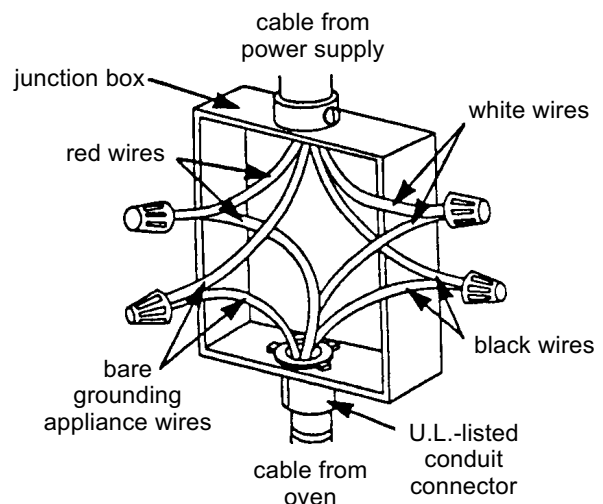

***Separate Grounding Conductors To White (Neutral) & Bare Wires***

## REMOVING & REINSTALLING THE OVEN DOOR

### **! WARNING**

#### **PERSONAL INJURY HAZARD**

- Use both hands to remove oven doors.
- Do not use the handle or any portion of the front frame or trim for lifting.
- Because of the weight and size of the oven, two or more people are required to move and safely install it.

Failure to properly grasp the oven doors or to lift the oven properly could result in personal injury or damage to the product.

**CAUTION:** Do not remove the shipping base or the shipping feet at the front lower corners of the oven. The shipping feet will protect the lower oven trim until the oven is inserted into the cabinet cutout.

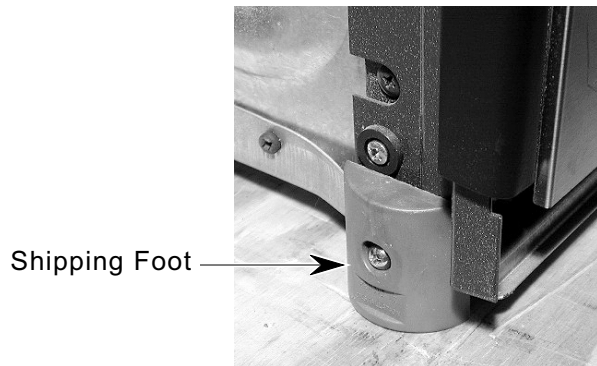

#### **To remove the oven door:**

1. Install a pin in the hole of each oven door hinge hanger.

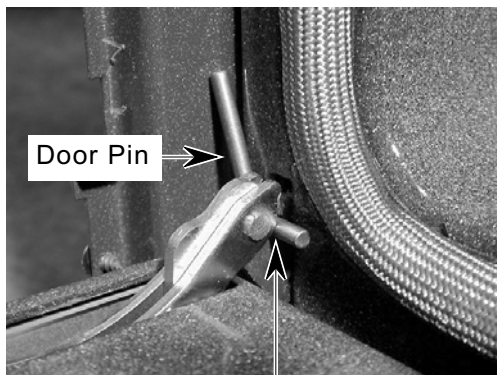

Door Pin Into Hinge Hanger Hole

2. Close the oven door as far as the two pins will allow.
3. Grasp the sides of the door and lift the door until it stops, then pull the hinge hangers out of the slots.

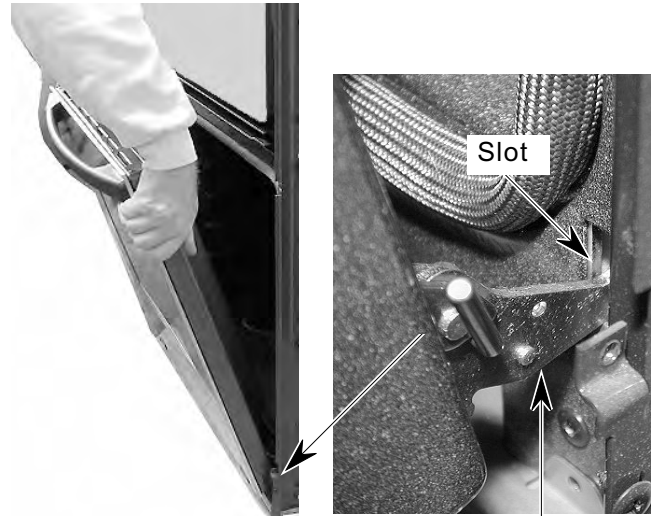

Hinge Hanger

#### **To reinstall the oven door:**

1. Grasp the sides of the door and tilt it back at a slight angle, then insert the hinge hangers into the hinge slots as far as they will go.
2. Rotate the top of the door towards the oven so the hinge hangers fit onto the support pins.
3. Close the oven door as far as the pins will allow, and make sure that the hinge hangers are fully seated on the support pins. If they are not seated properly, the door will not close tightly and may be off-center. To seat the hinge hangers, open the door slightly, and push in on the bottom until the hangers are fully seated.
4. Open the oven door to its fully open position and remove the two hinge hanger pins.
5. Close the oven door completely and check it for proper operation and alignment.

# OVEN / COOKTOP COMBINATION-APPROVED INSTALLATION

The following built-in ovens are approved for installation over electric and gas cooktops, as noted.

## U.S. MODELS

BUILT-IN OVENS	
KEBI141D / KEBS147D / KEBI171D / KEBS177D / KEBI101D	
KEBS107D / GBS277PD / GBS307PD / RBS240PD / RBS245PD	
RBS270PD / RBS275PD / RBS277PD / RBS305PD / RBS307PD	
ELECTRIC COOKTOPS	GAS COOKTOPS
KECC563H	KGCT055G
KECC501G	KGCT305G
KECC502G	KGCT365G
KECC507G	KGCT366G
KECC508G	GLT3014G
KECC562G	GLT3614G
KECC576G	GLT3615G
KECC568G	KGCS105G
RCC3024G	KGCS166G
GJC3034G	KGCS127G
GJC3634G	SCS3004G
KECS100G	SCS3014G
KECS161G	SCS3614G
RCS3004G	KGCT305E
RCS3014G	KGCT365E
RCS3614G	KGCT366E
GJ8646XD	SC8640ED
KECC501B	SC8830EB
KECC502B	SC8836EB
KECC507B	GL8856EB
KECC560B	
KECC567B	
GJ8640XB	
RC8600XB	
RC8640XB	
RC8200XB	
RC8400XB	
KECS100S	

## CANADIAN MODELS

BUILT-IN OVENS
YKEBS177D / YKEBS107D / YKEBI101D / YGBS277PD
YRBS275PD / YRBS277PD / YRBS305PD / YRBS307PD
ELECTRIC COOKTOPS
YKECC502G
YKECC507G
YKECC567G
GJC3034G
GJC3634G
RCC3024G
RCS3014G



# THEORY OF OPERATION

## AIR FLOW

Intake air is drawn into the oven at two locations: through the control panel vent, (over the latch assembly and the inner chassis top), and through the side mounting rails (over the oven sides and around the back). Air also enters the oven at the back through the openings on the upper section of the rear cover. At this point, the air from the sides and the top mix. The air is then pulled through the blower, down the back of the unit between the outer and inner rear covers, and out the front of the unit via the bottom vent trim.

Air from the blower is forced over the cavity vent. The pressure differential causes air to be drawn from the cavity, where the air exits through a small opening on the left side of the control panel vent.

Air passes through the oven door by a combination of natural and forced convection. Air enters the door through the bottom slots, and passes between the outer glass, and the angled inner glass. This air exits through the top slots in the door via natural convection. Air also enters the bottom of the door, and is drawn between the two pieces of inner door glass, where it exits through the top slots in the upper part of the door. This air is then drawn into the blower, and is forced down the back of the unit between the inner and outer chassis covers, and finally out the bottom vent.

The purpose of the convection fan is to circulate hot air inside the oven cavity, not to evacuate the air. Thus, the air flow for the convection models and the non-convection models, is the same.

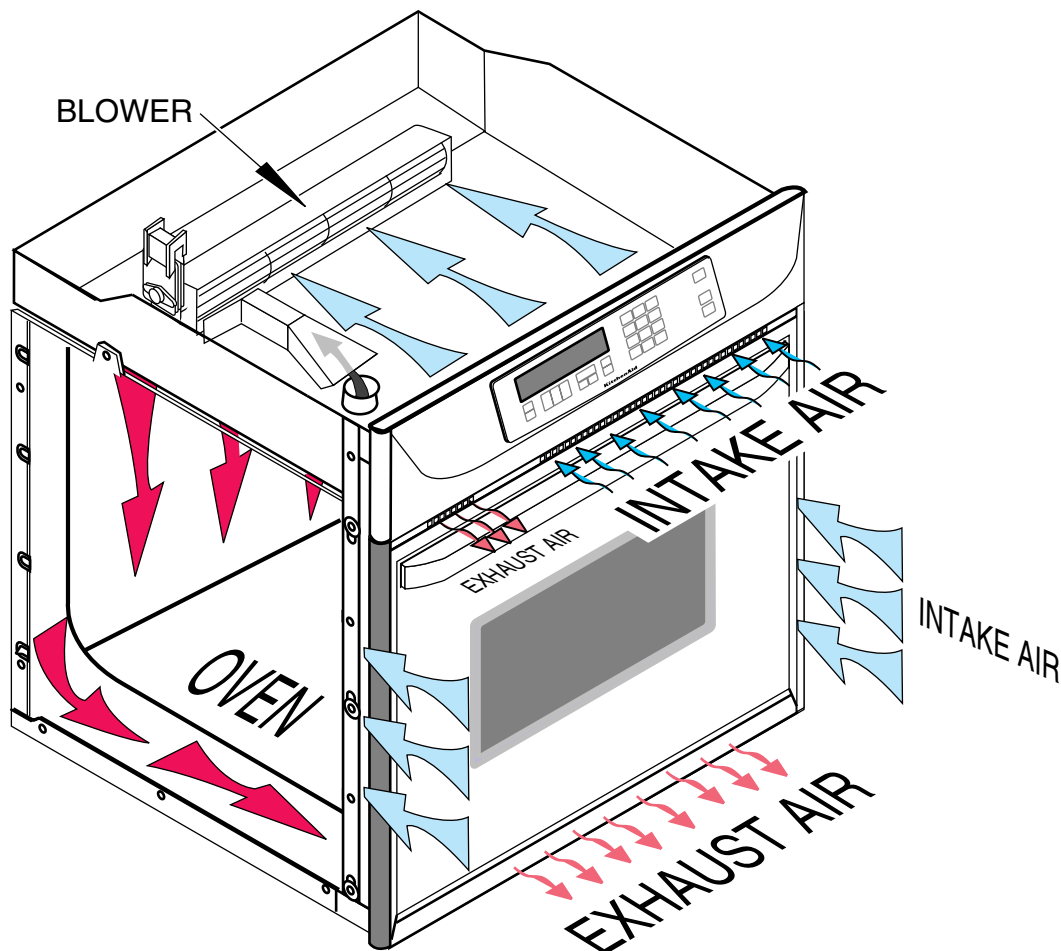

# THE OVEN SHUTDOWN THERMAL FUSE

The thermal fuse is located on the rear of the oven at the indicated location. The oven shutdown thermal fuse opens L2 to the oven if the temperature at the rear panel exceeds 160°C/ 320°F. The fuse is a one-time, non-resettable safety device.



Oven Shutdown Thermal Fuse

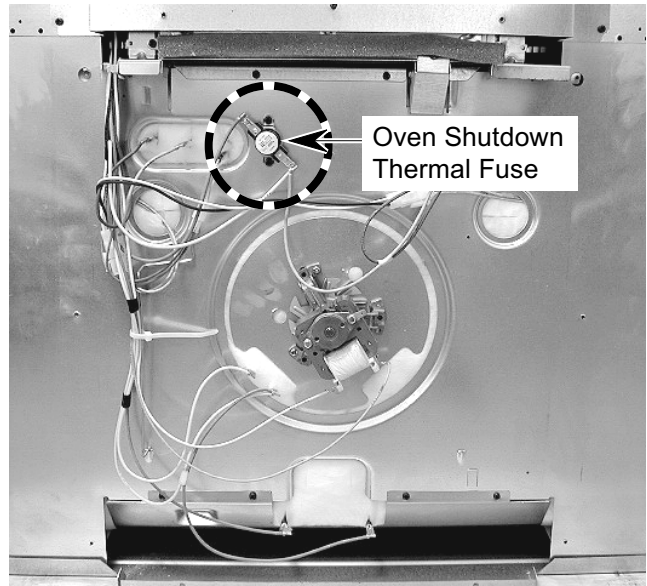

BACK OF OVEN

# THE OVEN DOOR LATCH ASSEMBLY

The door latch solenoid operates on a 120-volt dc pulse from the electronic control board. When the solenoid plunger is retracted, the oven door is in the “unlocked” position. When the solenoid plunger is extended, the oven door is in the “locked” position. When the door lock switch is open, the control senses that the door is “unlocked.” When the door lock switch closes, the control senses that the door is locked. The door lock switch, mounted on the solenoid bracket, is in the N.O. (normally-open) position.

During the self-clean cycle, the control board sends a 120-volt dc pulse to the solenoid windings, which extends the plunger (pushes it out), and moves the latch arm to lock the oven door. The movement of the arm also actuates the door lock switch arm, and closes it. When the self-clean cycle is over, the control board sends a 120-volt dc pulse to the solenoid, the plunger is retracted (pulled in), the latch arm releases the door, and the door lock switch opens.

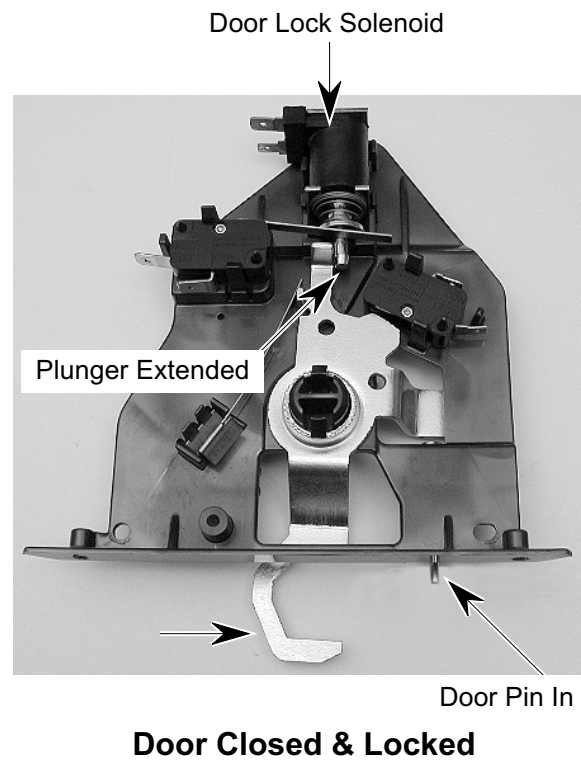
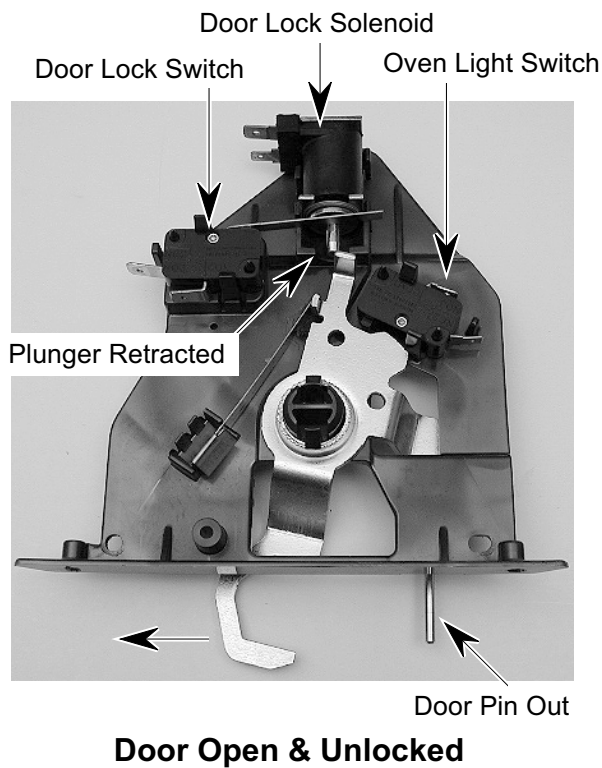

# HOW THE SELF-CLEAN CYCLE WORKS

The Self-Clean cycle uses high heat to burn away soil and grease from inside the oven. During this cycle, the oven will get much hotter than it does under normal baking and broiling conditions (see the following chart).

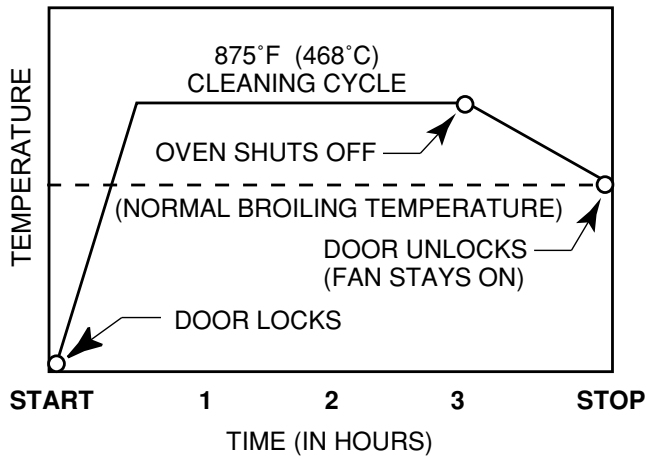

The oven is preset for a 3-1/2 hour Self-Clean cycle. However, you can adjust this cycle time to between 2-1/2 and 4-1/2 hours. The chart shows a normal 3-1/2 hour Self-Clean cycle. Note that although the heating turns off after 3-hours, the door will remain locked for an additional 1/2 hour so the oven can cool sufficiently.

If the latch switch is not satisfied during the clean operation, the cycle is terminated, and the display will show "close door" on convection models. On non-convection models, "door" will be displayed (see the strip circuit below).

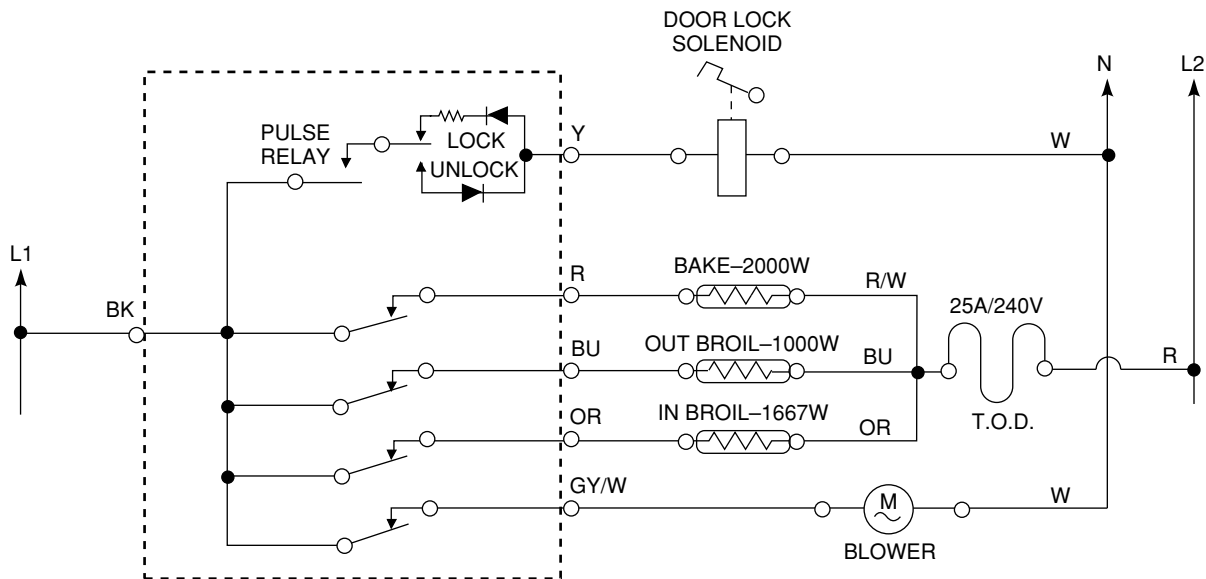

# COMPONENT ACCESS

This section instructs you on how to service each component inside the Electric Built-In Single Oven. The components and their locations are shown below.

## COMPONENT LOCATIONS

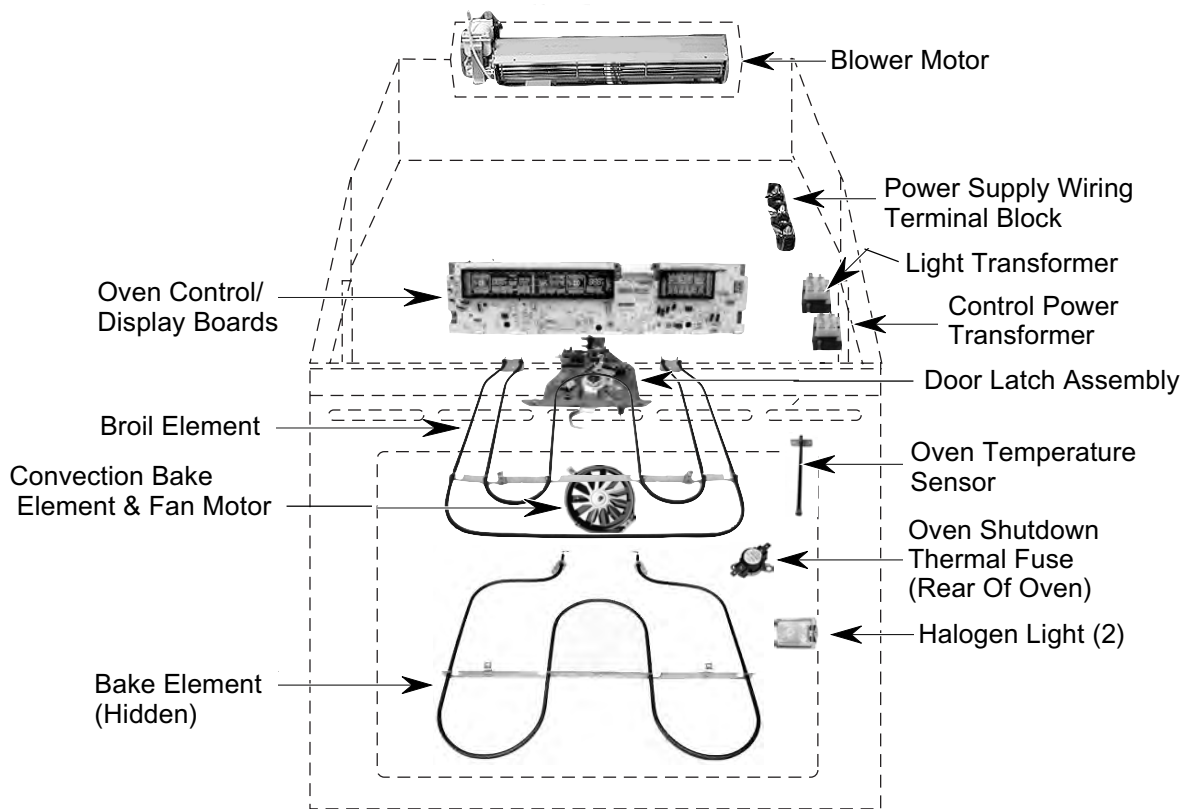

# REMOVING THE OVEN CONTROL/DISPLAY BOARDS, AND THE TOUCH PANEL ASSEMBLY

## **! WARNING**

### **ELECTRICAL SHOCK HAZARD**

Disconnect power before servicing.  
Replace all panels before operating.  
Failure to do so could result in death or electrical shock.

**CAUTION:** When you work on the built-in oven, be careful when handling the sheet metal parts. Sharp edges may be present, and you can cut yourself if you are not careful.

1. Disconnect the electrical power to the oven.
2. Open the oven door.
3. Remove the bottom screw from each of the two side trim pieces (see below).
4. To remove the side trim, pull the bottom out approximately 2", and slide the top down to free it from the control panel.



Side Trim Screw  
(1 On Each Side)

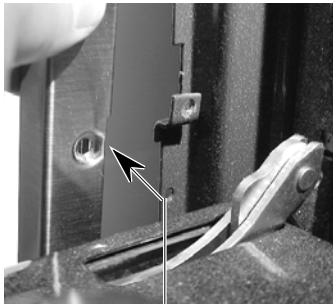

Pull Out Bottom  
Of Side Trim



Pull Side Trim  
Down & Away  
From Control  
Panel

5. Remove the screws from the oven control panel.



Control  
Panel  
Screw

6. To remove the oven control panel, pull it out at the bottom, and lift and unhook it from the oven cabinet support at the top.

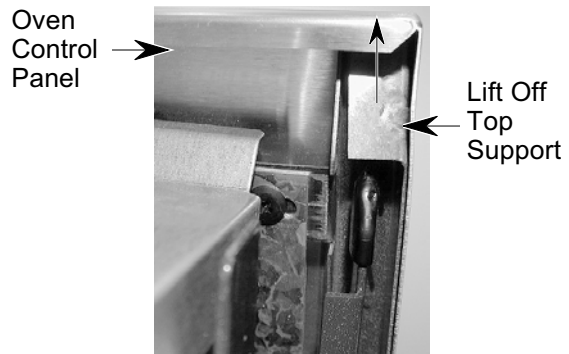

Oven  
Control  
Panel

Lift Off  
Top  
Support

7. Disconnect the wire connectors from the control board and set the panel assembly face down on a padded surface to protect the finish.

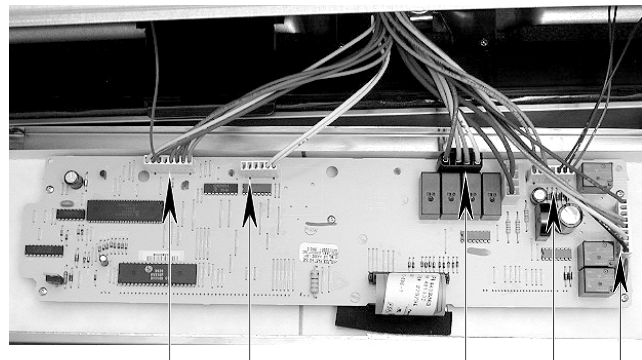

5 Wire Connectors

8. **To remove the oven control/display boards:**

a) Remove the five mounting screws.

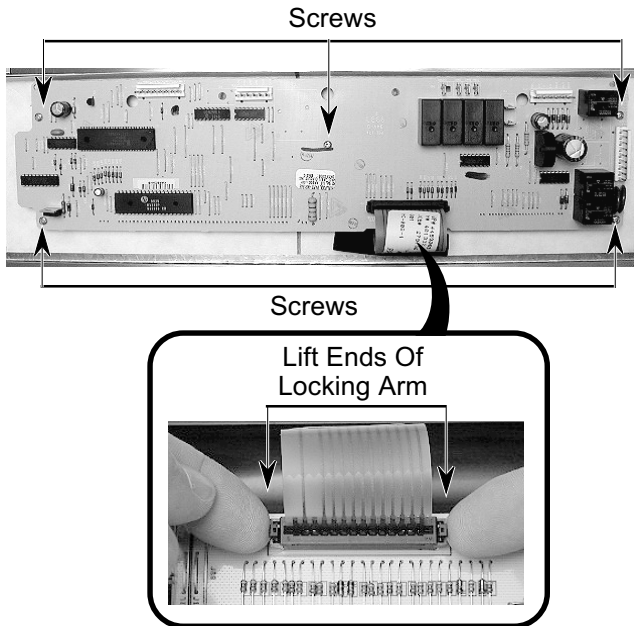

b) Lift the ends of the locking arm and disconnect the ribbon cable from its connector.

NOTE: The control and display boards are designed to be replaced as an assembly.

9. **To remove the touch panel assembly:**

a) Remove the seven spacers and the cardboard shield from the panel.

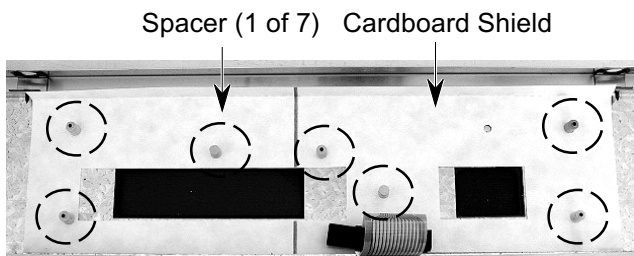

b) Remove the six screws from the control panel bracket and remove the bracket.

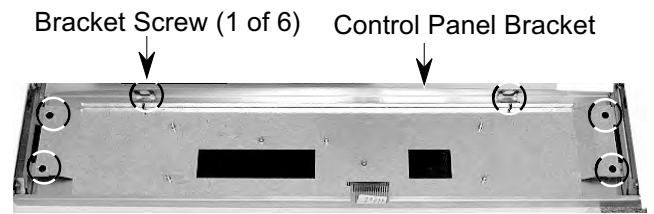

c) Peel the touch panel off the bracket.

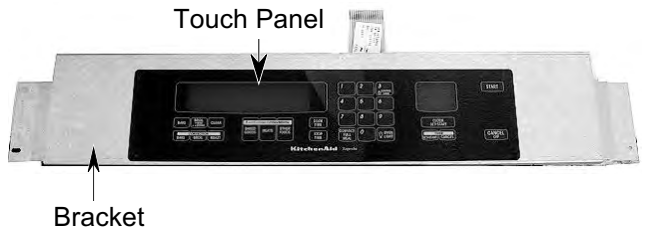

REASSEMBLY NOTE: When you reinstall the oven control panel, use the following procedure (refer to the photos on the previous page, as necessary):

1. Reconnect the wiring to the control board terminals.
2. Hook the ends of the control panel over the rubber tips of the brackets.
3. Push the bottom of the control panel in and position the plastic air duct under the lip of the panel.

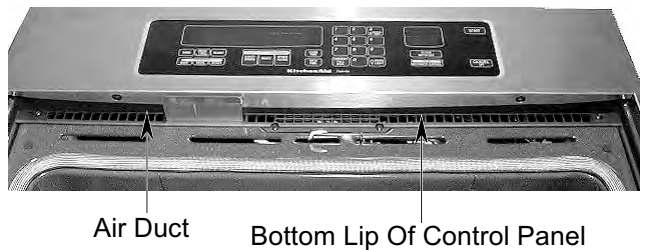

4. Align the mounting holes and install the two side screws in the control panel.

# REMOVING THE POWER SUPPLY WIRING TERMINAL BLOCK AND THE BLOWER MOTOR

## **! WARNING**

### **ELECTRICAL SHOCK HAZARD**

Disconnect power before servicing.  
Replace all panels before operating.  
Failure to do so could result in death or electrical shock.

**CAUTION:** When you work on the built-in oven, be careful when handling the sheet metal parts. Sharp edges may be present, and you can cut yourself if you are not careful.

1. Disconnect the electrical power to the oven.
2. Remove the side trim from the oven (see page 4-2, steps 1 through 4 for the procedure).

**NOTE:** Before you move the oven from its mounting location, remove the oven door to make it easier to move (see page 2-3 for the procedure).

3. Remove the oven cabinet mounting screws and pull the oven out of its mounting location so that you can access the back.



Cabinet Mounting Screw  
(1 Screw On Each Side)

4. Remove the screw from the conduit clamp and remove the clamp.
5. Remove the 6 screws from the top rear oven cabinet cover.

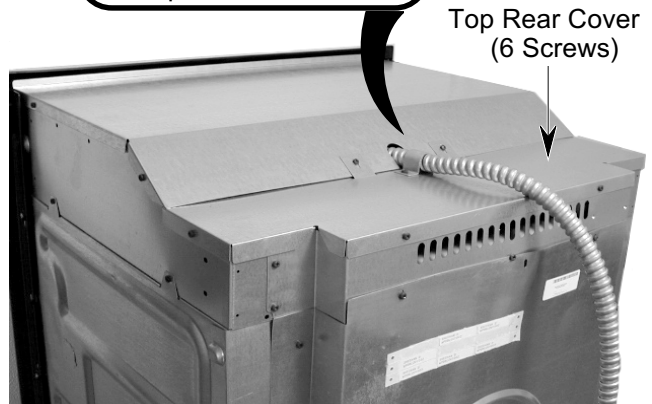
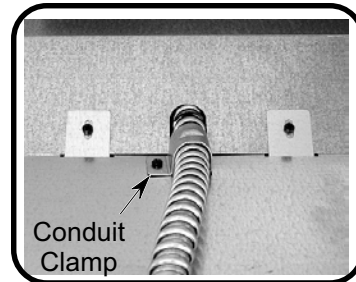

6. **To remove the power supply wiring terminal block:**
  - a) Remove the hex nuts from the wire terminal studs and remove the wires from the studs.
  - b) Remove the two mounting screws from the terminal block and remove it from the top of the oven.

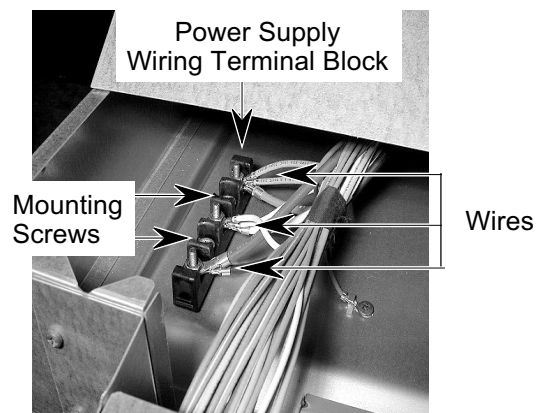



7. **To remove the blower motor assembly:**

a) Remove the rear cover from the oven (11 screws).

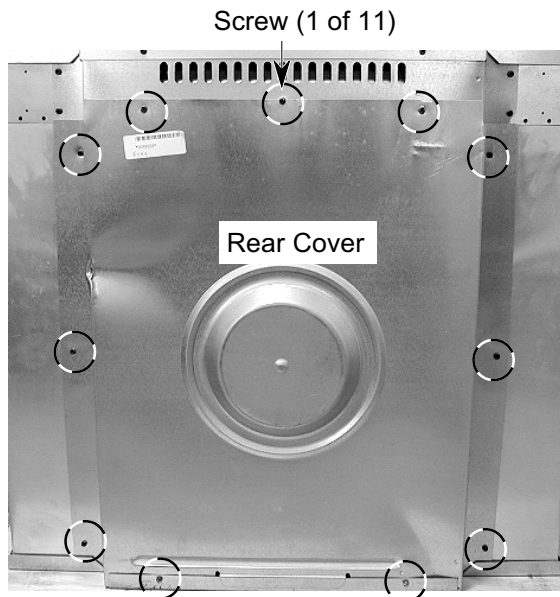

b) Remove the four screws from the blower cover and remove the cover.

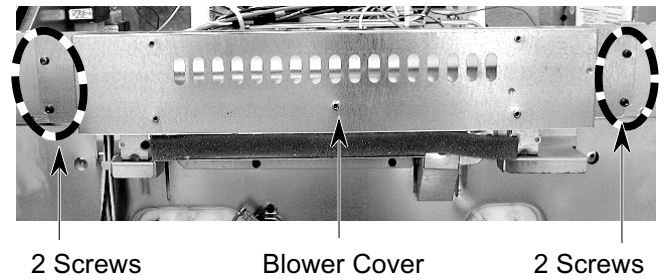

c) Disconnect the two wires from the blower motor terminals.

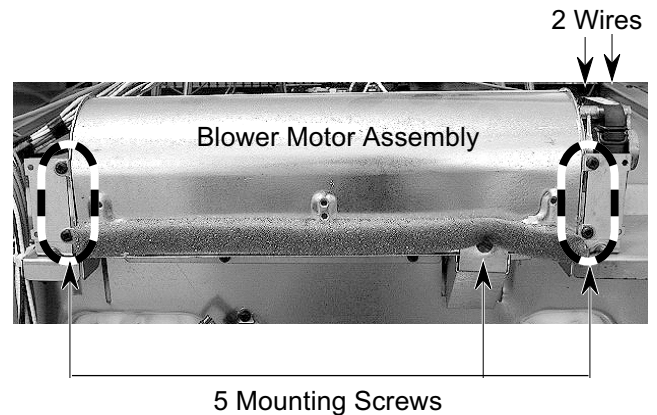

d) Remove the five mounting screws.

# REMOVING THE OVEN LIGHT TRANSFORMER & THE CONTROL POWER TRANSFORMER

## ⚠️ WARNING

### ELECTRICAL SHOCK HAZARD

Disconnect power before servicing.  
Replace all panels before operating.  
Failure to do so could result in death or electrical shock.

**CAUTION:** When you work on the built-in oven, be careful when handling the sheet metal parts. Sharp edges may be present, and you can cut yourself if you are not careful.

1. Disconnect the electrical power to the oven.
2. Remove the control panel from the oven (see page 4-2, steps 1 through 6 for the procedure). Position the control panel forward so you can access either transformer.

Oven Light & Control Power Transformers



3. Remove the mounting screw from the transformer you are servicing and unhook the tab from the oven chassis slot.

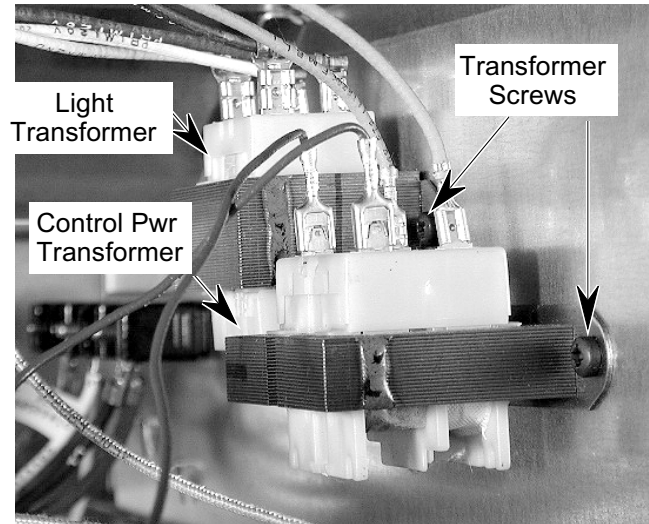

4. Disconnect the four wires from the LOAD and LINE terminals of the transformer. NOTE: The LOAD and LINE terminals are different sizes so that you cannot make a mistake when reconnecting the wires (see below).

Light Transformer  
Wht & Blk (Small)

Control Power Transformer  
(2) Red (Small)

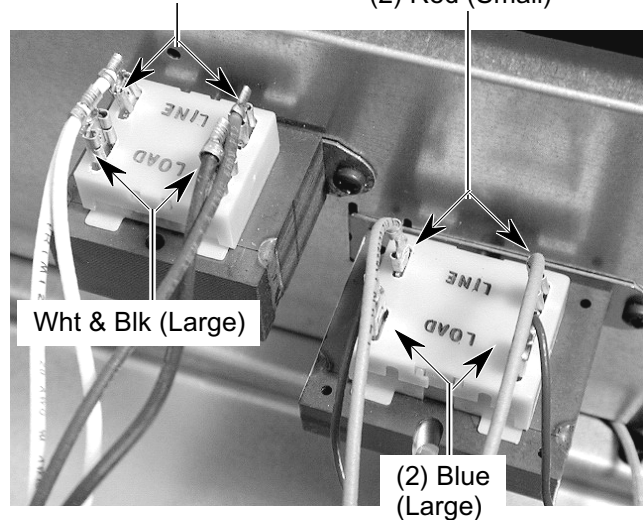

## REMOVING THE OVEN DOOR LATCH ASSEMBLY

### **! WARNING**

#### **ELECTRICAL SHOCK HAZARD**

Disconnect power before servicing.  
Replace all panels before operating.  
Failure to do so could result in death or electrical shock.

**CAUTION:** When you work on the built-in oven, be careful when handling the sheet metal parts. Sharp edges may be present, and you can cut yourself if you are not careful.

1. Disconnect the electrical power to the oven.
2. Remove the control panel from the oven (see page 4-2, steps 1 through 6 for the procedure).

3. Open the oven door and remove the two front oven door latch mounting screws from the air vent.

Oven Door Latch Assembly

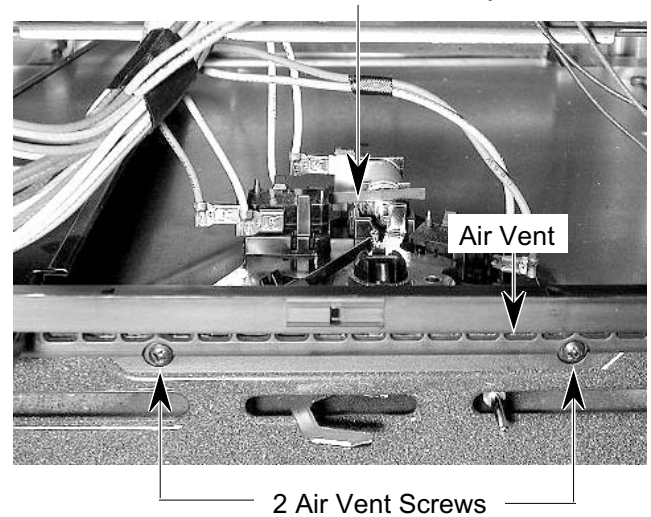

4. Remove the wires from the terminals of the solenoid and the latch and door switches.

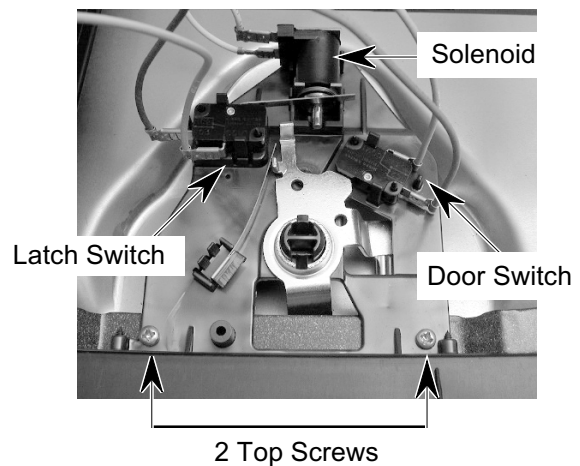

5. Remove the two top screws from the oven door latch assembly and remove the assembly.

# REMOVING AN OVEN HALOGEN LIGHT & THE OVEN TEMPERATURE SENSOR

## **! WARNING**

### **ELECTRICAL SHOCK HAZARD**

Disconnect power before servicing.  
Replace all panels before operating.  
Failure to do so could result in death or electrical shock.

**CAUTION:** When you work on the built-in oven, be careful when handling the sheet metal parts. Sharp edges may be present, and you can cut yourself if you are not careful.

1. Disconnect the electrical power to the oven.
2. Open the oven door and remove the racks from inside the oven.

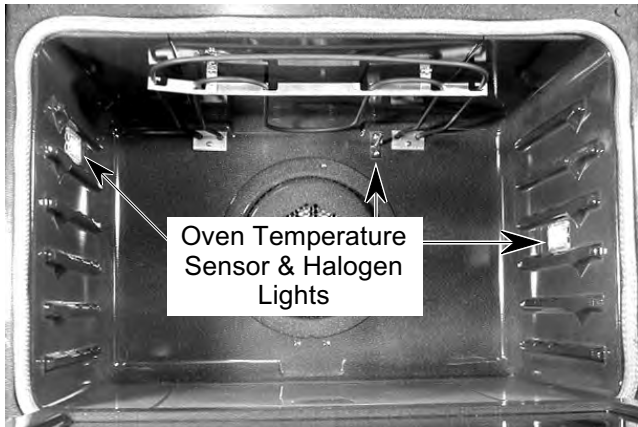

3. To remove an oven halogen light:

- a) Remove the lens from the halogen light socket by lifting the end near the mounting screw and unsnapping it.
- b) Remove the screw from the halogen light assembly.

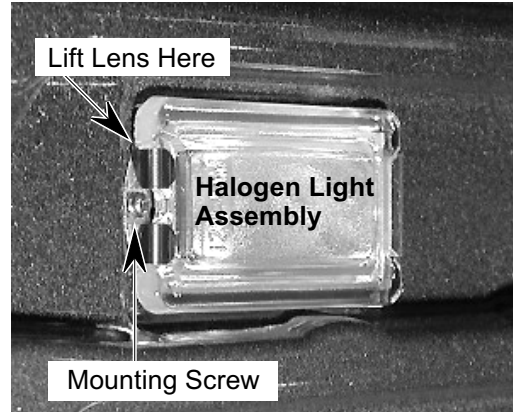

- c) Pull the halogen bulb out of the socket.

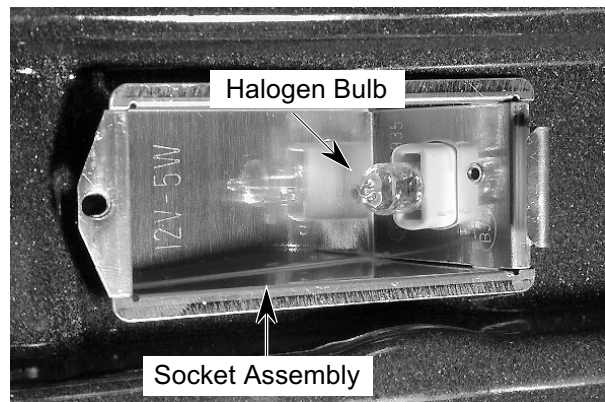

- d) Pull the halogen socket assembly out of the oven liner and cut the wires near the socket terminals.



- e) Cut the new halogen light socket wires to the proper length.  
f) Remove 3/8" of insulation from the cut wires on the wire harness and the halogen light socket. Splice the halogen light socket wires to the harness wires, and twist two wire nuts over the bare wire ends.

4. **To remove the oven temperature sensor:**

- a) Remove the two mounting screws from the oven temperature sensor and pull the connector out of the mounting hole in the oven liner.

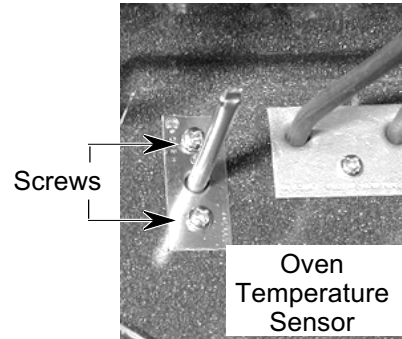

- b) Disconnect the sensor connector from the main wire harness connector.

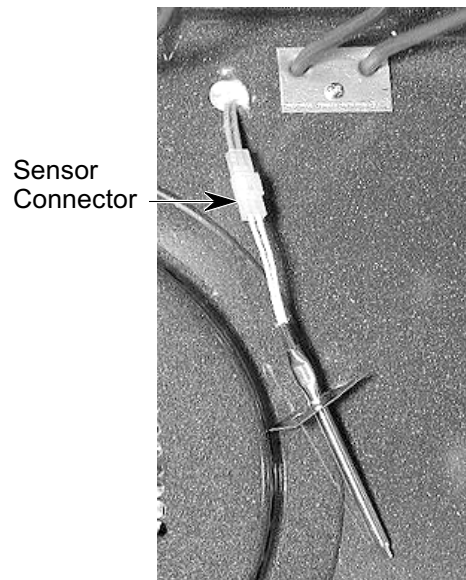

## REMOVING THE BROIL ELEMENT

### **! WARNING**

#### **ELECTRICAL SHOCK HAZARD**

Disconnect power before servicing.  
Replace all panels before operating.  
Failure to do so could result in death or electrical shock.

**CAUTION:** When you work on the built-in oven, be careful when handling the sheet metal parts. Sharp edges may be present, and you can cut yourself if you are not careful.

1. Disconnect the electrical power to the oven.
2. Open the oven door and remove the racks from inside the oven.

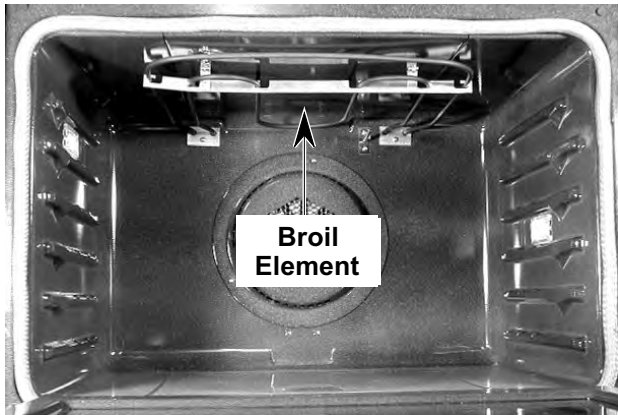

3. Remove the two front bracket screws and two rear bracket screws from the broil element.

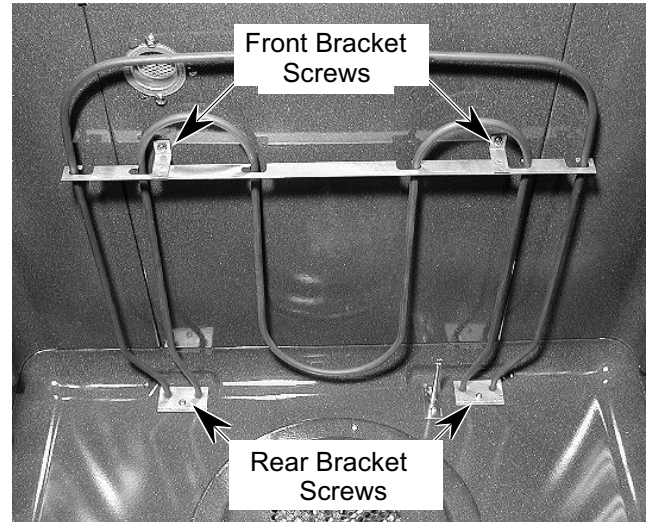

4. Carefully pull the element forward so that the wires are through the oven liner holes, and disconnect the wires from the terminals.

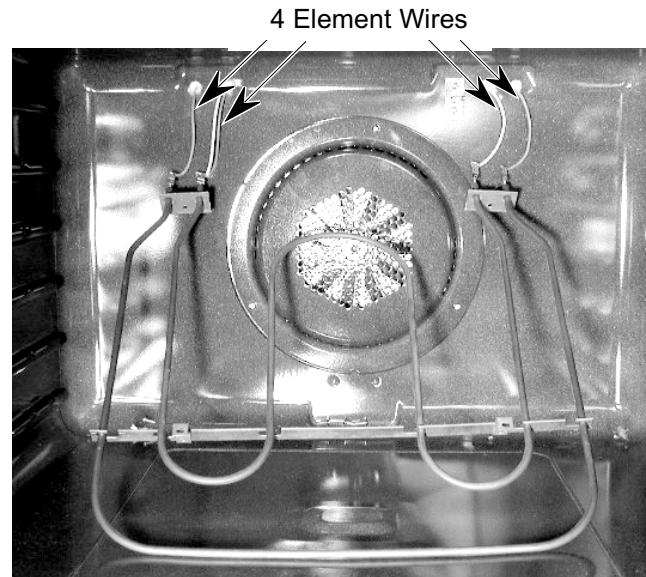

## REMOVING THE MEAT PROBE JACK

### **! WARNING**

#### **ELECTRICAL SHOCK HAZARD**

Disconnect power before servicing.  
Replace all panels before operating.  
Failure to do so could result in death or electrical shock.

**CAUTION:** When you work on the built-in oven, be careful when handling the sheet metal parts. Sharp edges may be present, and you can cut yourself if you are not careful.

1. Disconnect the electrical power to the oven.
2. Remove the racks from inside the oven.

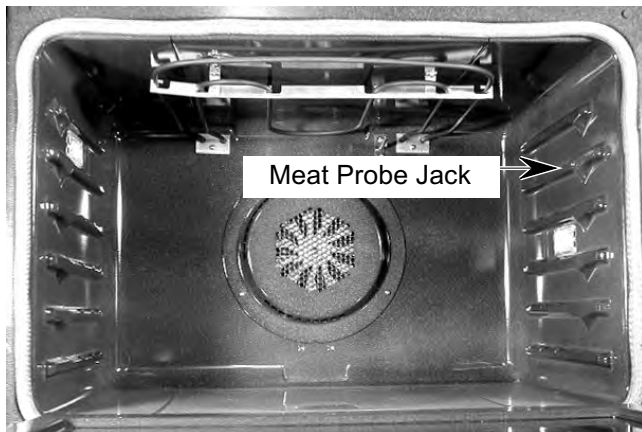

3. Remove the hex nut from the meat probe jack.

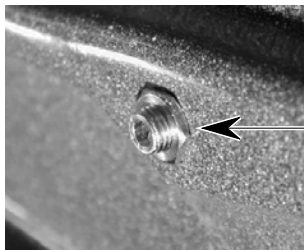

4. Pull the oven out of its mounting location approximately 8", (see page 4-4 steps 1 through 3 for the procedure), so that you can access the meat probe jack access panel on the right side.

5. Remove the meat probe jack access panel from the right side of the unit. Use a pair of small cutters to clip the bridge.

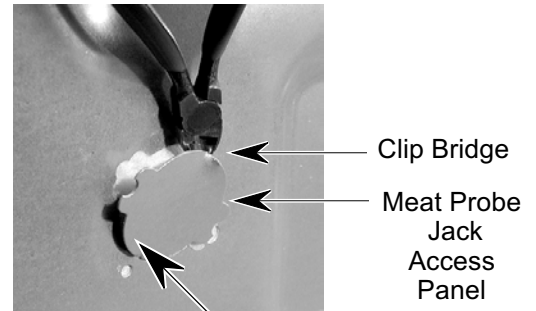

6. Push aside the insulation, pull the meat probe jack out of the access hole, and remove the star washer from the jack.
7. Cut the wires near the lugs of the old meat probe jack, then use two small wire nuts, and splice the new jack to the oven wires.

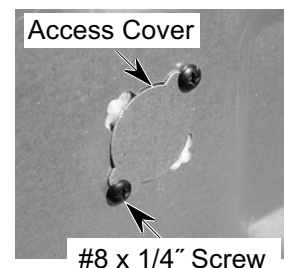
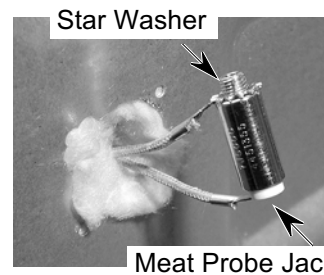

**REASSEMBLY NOTE:** When you install the new jack, be sure to place the star washer from the old jack on the threaded end of the new one. After you have installed the jack, mount the access cover with two #8 x 1/4" screws.

# REMOVING THE HIDDEN BAKE ELEMENT

## **! WARNING**

### **ELECTRICAL SHOCK HAZARD**

Disconnect power before servicing.  
Replace all panels before operating.  
Failure to do so could result in death or electrical shock.

**CAUTION:** When you work on the built-in oven, be careful when handling the sheet metal parts. Sharp edges may be present, and you can cut yourself if you are not careful.

1. Disconnect the electrical power to the oven.
2. Pull the oven out of its mounting location so that you can access the rear cover (see page 4-4, steps 1 through 3 for the procedure).
3. Remove the rear cover from the oven (see page 4-5 for the procedure).

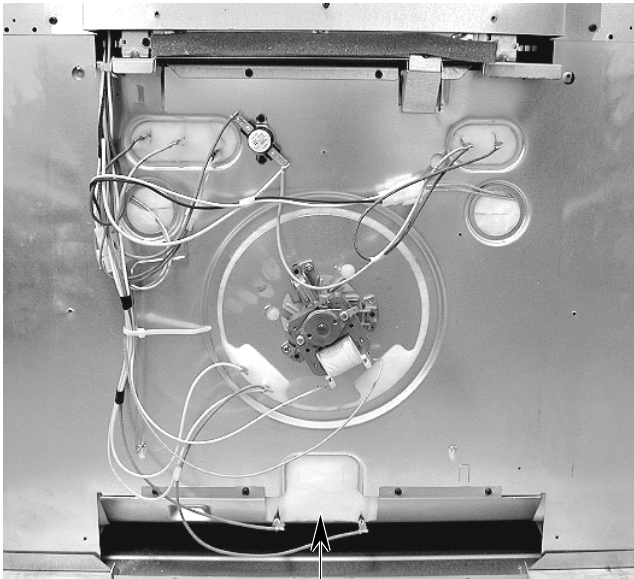

Hidden Bake Element

4. Remove the four screws from the hidden bake element cover flange.

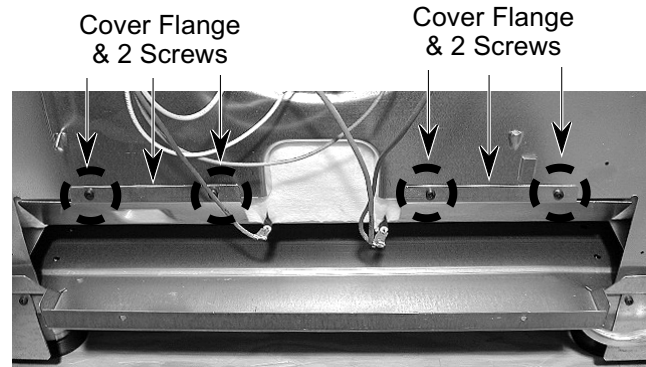

5. Bend the cover flanges down as far as they will go.

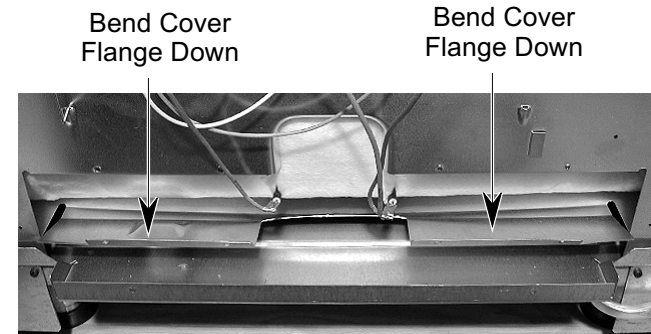

6. Use a pen knife or a single-edged razor blade and cut the insulation blanket, as shown. Be sure to separate the insulation blanket as cleanly as possible.

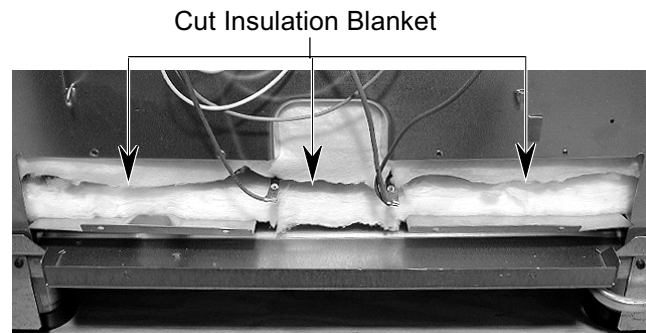

7. Carefully move the insulation blanket out of the way so that you can access the hidden bake element mounting bracket.



8. Remove the four mounting bracket screws and the two hidden bake element bracket screws.

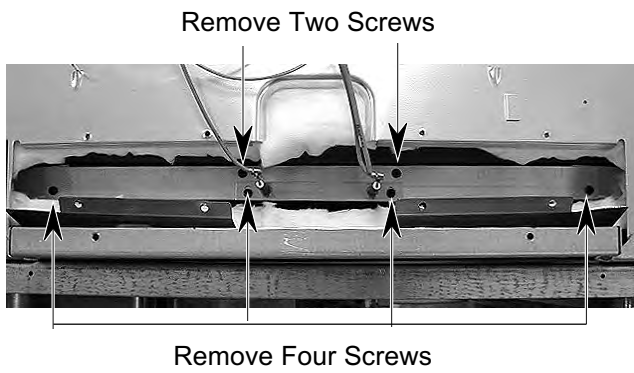

9. Carefully pull the hidden bake element and its mounting bracket out of the oven.

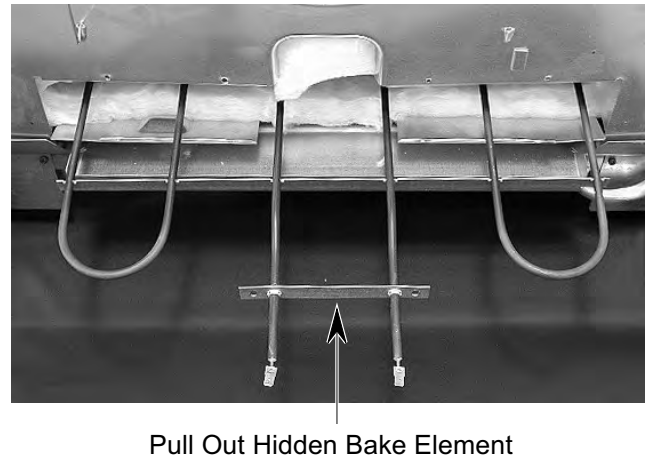

# REMOVING THE CONVECTION BAKE ELEMENT AND THE FAN MOTOR ASSEMBLY

## **! WARNING**

### **ELECTRICAL SHOCK HAZARD**

Disconnect power before servicing.  
Replace all panels before operating.  
Failure to do so could result in death or electrical shock.

**CAUTION:** When you work on the built-in oven, be careful when handling the sheet metal parts. Sharp edges may be present, and you can cut yourself if you are not careful.

1. Disconnect the electrical power to the oven.
2. To make servicing easier, remove the oven door from the unit (see page 2-3 for the procedure).
3. Remove the racks from inside the oven.

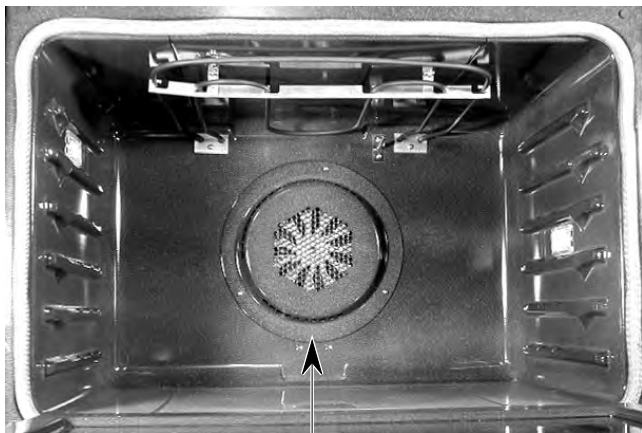

Convection Bake Element & Fan Motor

4. Remove the three screws from the convection cover and remove the cover from the rear of the oven liner. Note the location of the notch in the cover. Be sure to

position the cover with the notch as shown when you reinstall it.

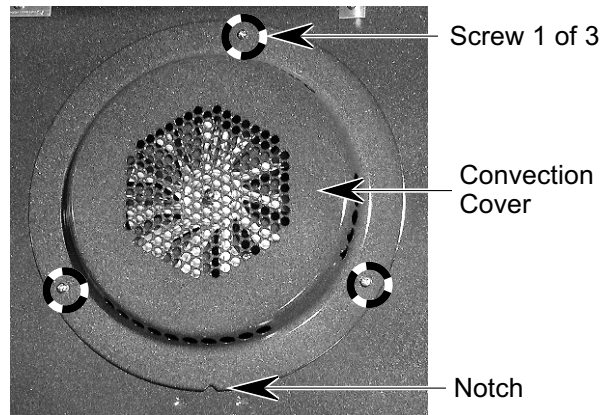

5. **To remove the convection bake element:**

- a) Remove the two screws from the convection bake element.
- b) Pull it forward so you can access the terminals.
- c) Disconnect the wires from the element terminals.

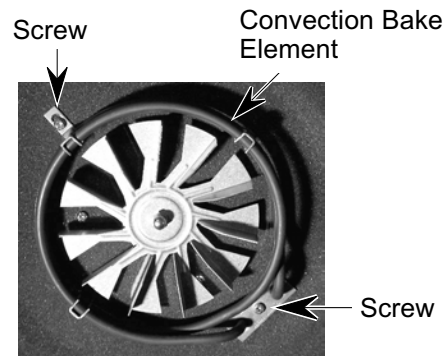

Element Terminals

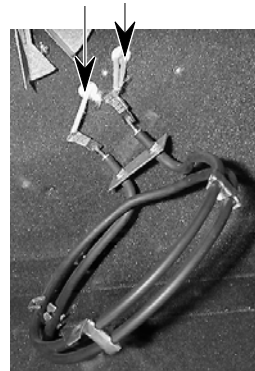

6. **To remove the convection fan motor:**

- a) If not already done, remove the convection cover and the convection bake element from the rear of the oven liner (see page 4-14).
- b) Use a 10 mm (7/16") socket and remove the hex nut from the convection fan. **NOTE:** The nut has a left-rotation thread for removal.

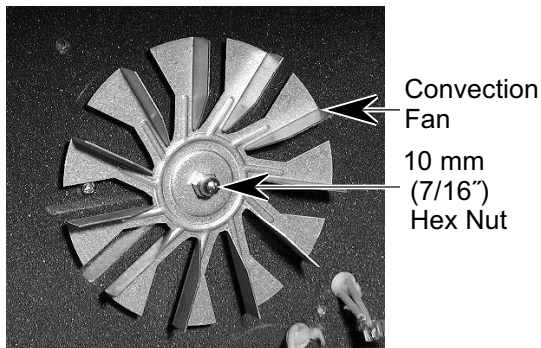

- c) Remove the three front convection fan motor screws from the rear of the oven liner.

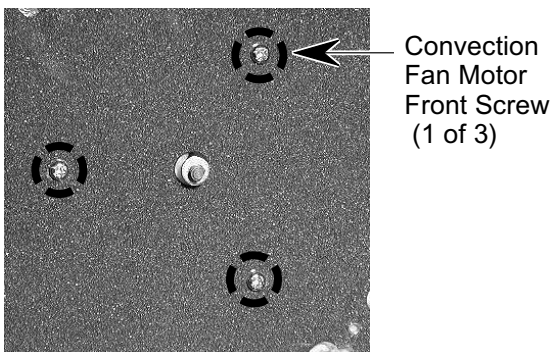

- d) Pull the oven out of its mounting location (see page 4-4, steps 1 through 3 for the procedure) so that you can access the rear cover.
- e) Remove the rear cover from the oven (see page 4-5 for the procedure).

- f) Remove the two rear convection fan motor mounting screws from the oven, and remove the motor from the rear of the oven.

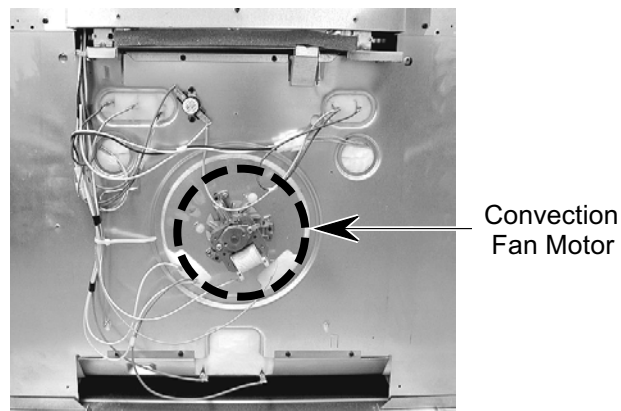

Convection Fan Motor Rear Screw (1 of 2)

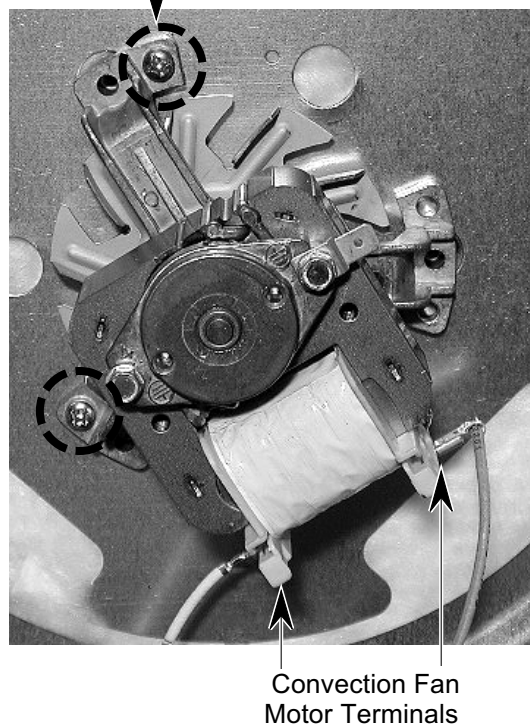

# REMOVING THE OVEN SHUTDOWN THERMAL FUSE

## **! WARNING**

### **ELECTRICAL SHOCK HAZARD**

Disconnect power before servicing.  
Replace all panels before operating.  
Failure to do so could result in death or electrical shock.

**CAUTION:** When you work on the built-in oven, be careful when handling the sheet metal parts. Sharp edges may be present, and you can cut yourself if you are not careful.

1. Disconnect the electrical power to the oven.
2. Pull the oven out of its mounting location, (see page 4-4 steps 1 through 3 for the procedure), so that you can access the rear cover.
3. Remove the rear cover from the oven (see page 4-5 for the procedure).

Oven Shutdown Thermal Fuse

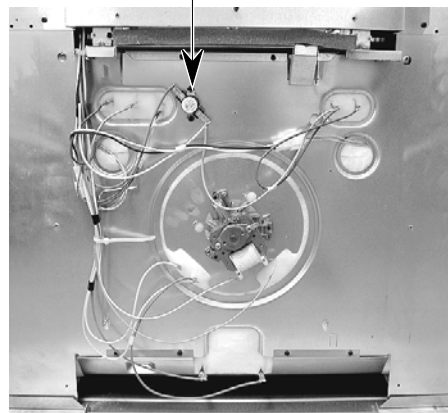

4. Disconnect the wires from the thermal fuse terminals.

Mounting Screw (1 of 2)

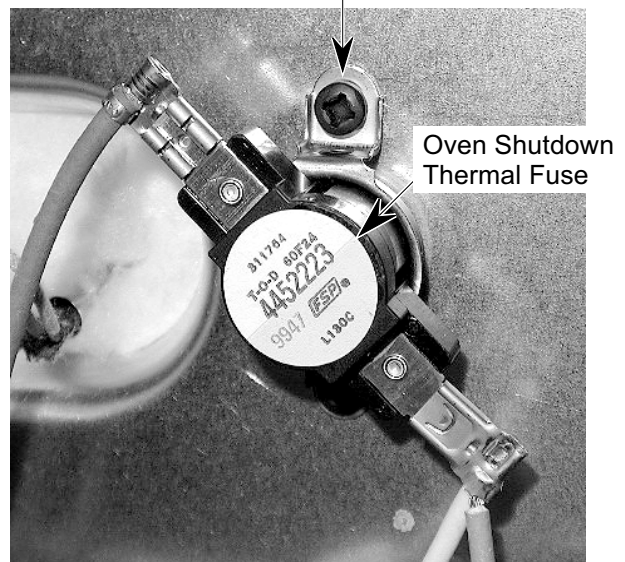

5. Remove the two screws and remove the fuse from the rear of the oven.

# REMOVING THE OVEN DOOR GLASS, HINGES, & HANDLE

**CAUTION:** When you work on the built-in oven, be careful when handling the sheet metal parts. Sharp edges may be present, and you can cut yourself if you are not careful.

1. Remove the oven door from the oven (see page 2-3 for the procedure).
2. Place the oven door on a padded work surface with the front decorative glass facing down.
3. Remove the two top door liner screws and the two door glass bracket screws, and lift the liner assembly off the decorative door glass and handle.

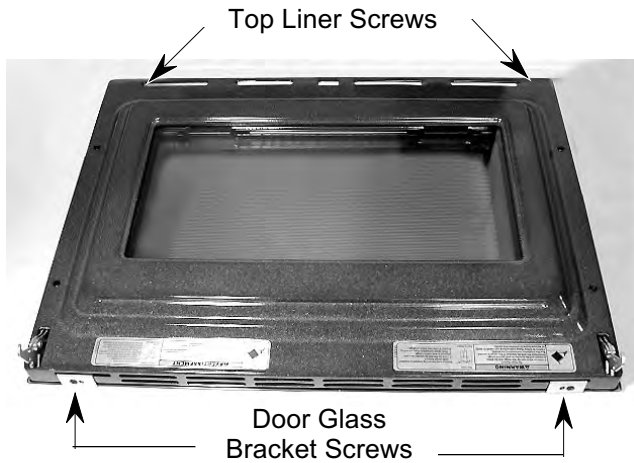

4. **To remove the outer door glass:**
  - a) Remove the three outer glass holder screws and two outer glass bracket screws from the door liner.
  - b) Lift the outer glass with the glass holder off the door liner.
  - c) Remove the bracket.

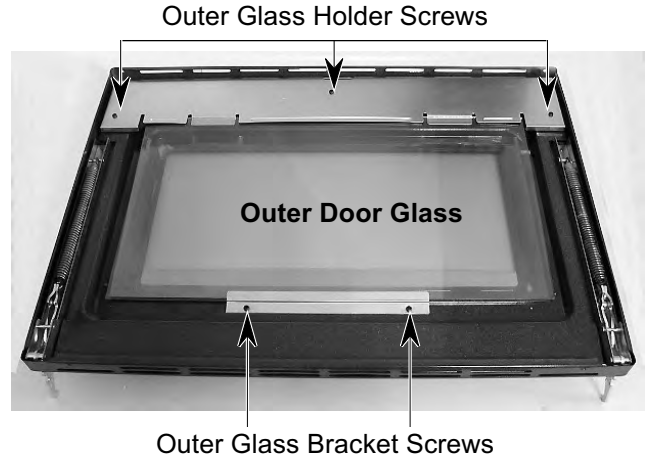

5. **To remove the center door glass,** remove the bottom bracket, (it is loose), and slide the two top corners of the glass out of the door liner slots.

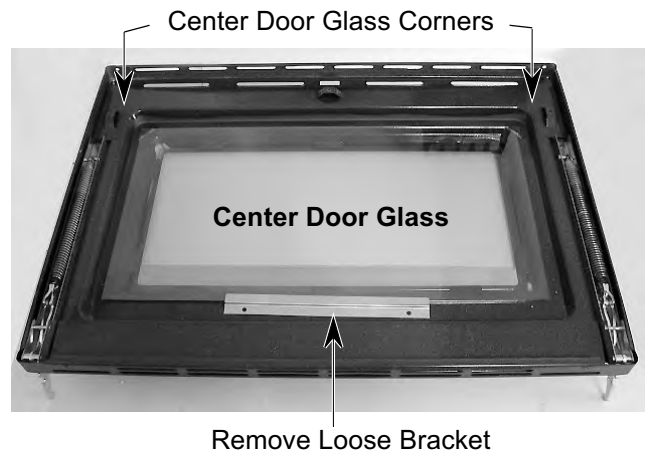

**Continued on the next page.**

6. **To remove the hinges and the inner door glass:**

NOTE: You will have to remove both hinges to remove the inner door glass from the oven door liner.

- a) Lift either side of the door liner, remove the two door hinge screws, and remove the hinge.



- b) Lift the other side of the door liner, remove the two screws for the other hinge, and remove the hinge.
- c) Lift the inner door glass liner cover off the liner.

- d) Remove the insulation and the inner door glass.

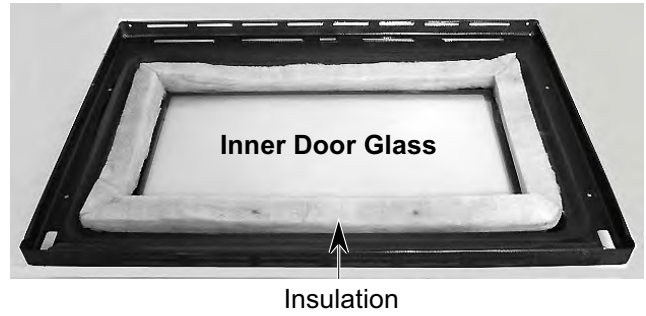

7. **To remove the door handle,** remove the two door handle screws from the bracket.

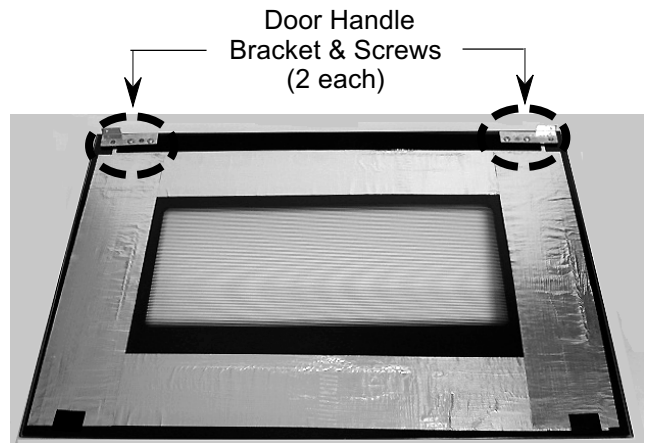

## REMOVING THE OVEN DOOR GASKET

**CAUTION:** When you work on the built-in oven, be careful when handling the sheet metal parts. Sharp edges may be present, and you can cut yourself if you are not careful.

1. Open the oven door to its fully open position.
2. Remove the screw from the door gasket bracket and remove the bracket from the oven.

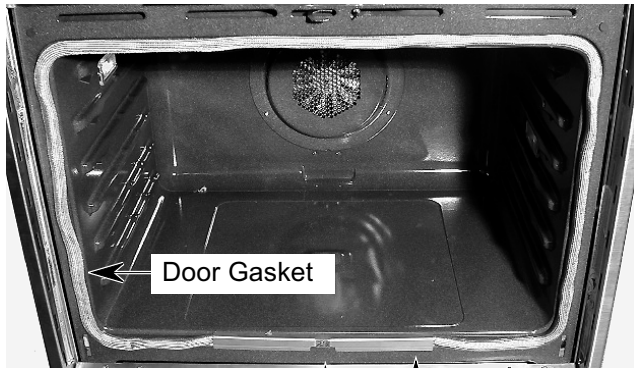

Screw      Gasket Bracket

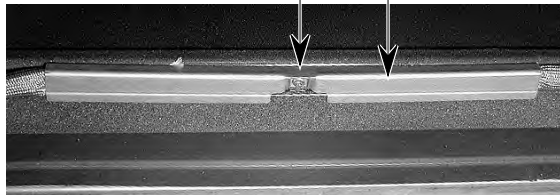

3. Pull the ends of the gasket out of the liner holes and pull the clips out of their liner holes.

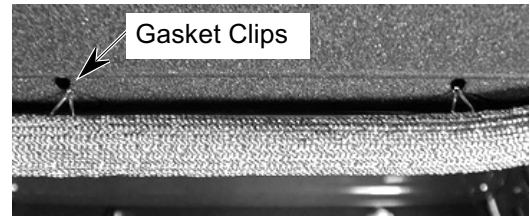

**REASSEMBLY NOTE:** When you install the new gasket, make sure that all of the clips are seated in their liner holes, and that the ends of the gasket are pushed fully into their holes. Use the pointed end of a pencil to push the gasket ends into the holes.

— NOTES —



# COMPONENT TESTING

Before testing any of the components, perform the following checks:

- The most common cause for control failure is corrosion on connectors. Therefore, disconnecting and reconnecting wires will be necessary throughout test procedures.
- All tests/checks should be made with a VOM or DVM having a sensitivity of 20,000 ohms-per-volt DC, or greater.

- Check all connections before replacing components, looking for broken or loose wires, failed terminals, or wires not pressed into connectors far enough.
- Voltage checks must be made with all connectors attached to the boards.
- Resistance checks must be made with power cord unplugged from outlet, and with wiring harness or connectors disconnected.

## **! WARNING**

### **ELECTRICAL SHOCK HAZARD**

Disconnect power before servicing.  
Replace all panels before operating.  
Failure to do so could result in death or electrical shock.

## **! WARNING**

### **ELECTRICAL SHOCK HAZARD**

Disconnect power before servicing.  
Replace all panels before operating.  
Failure to do so could result in death or electrical shock.

## **BLOWER MOTOR**

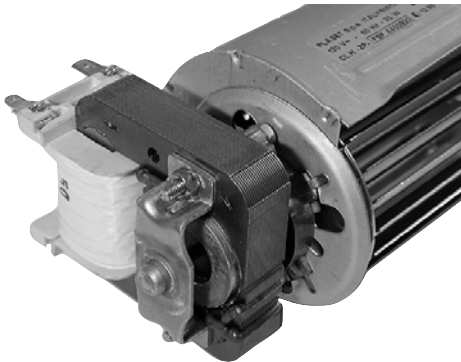

Refer to page 4-4 for the procedure for servicing the blower motor.

1. Disconnect the electrical power to the oven.
2. Disconnect the wires from the blower motor terminals.
3. Set the ohmmeter to the R x 1 scale.
4. Touch the ohmmeter leads to the motor terminals. The meter should indicate between 14 and 18  $\Omega$ .

## **OVEN TEMPERATURE SENSOR**



Refer to page 4-8 for the procedure for servicing the oven temperature sensor.

1. Disconnect the electrical power to the oven.
2. Disconnect the oven temperature sensor connector from the oven connector.
3. Set the ohmmeter to the R x 1K scale.
4. Touch the ohmmeter leads to the sensor connector pins. The meter should indicate 1080  $\Omega$  @ 70°F.

# **! WARNING**

## **ELECTRICAL SHOCK HAZARD**

Disconnect power before servicing.  
Replace all panels before operating.  
Failure to do so could result in death or electrical shock.

### **CONVECTION BAKE ELEMENT**

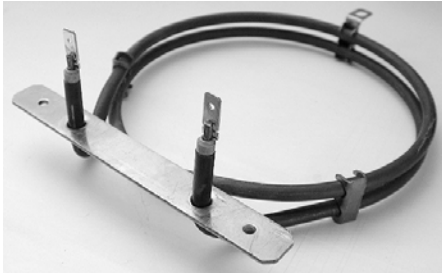

Refer to page 4-14 for the procedure for servicing the convection bake element.

1. Disconnect the electrical power to the oven.
2. Disconnect the wires from the convection bake element terminals.
3. Set the ohmmeter to the R x 1 scale.
4. Touch the ohmmeter leads to the element terminals. The meter should indicate between 28 and 35  $\Omega$ .

# **! WARNING**

## **ELECTRICAL SHOCK HAZARD**

Disconnect power before servicing.  
Replace all panels before operating.  
Failure to do so could result in death or electrical shock.

### **CONVECTION FAN MOTOR**

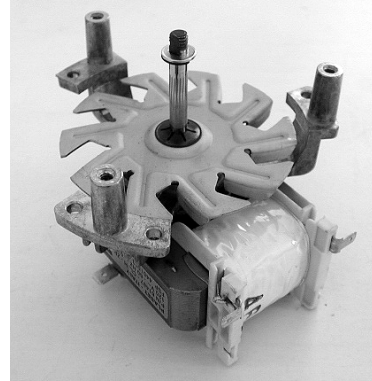

Refer to page 4-14 for the procedure for servicing the convection fan motor.

1. Disconnect the electrical power to the oven.
2. Disconnect the wires from the convection fan motor terminals.
3. Set the ohmmeter to the R x 1 scale.
4. Touch the ohmmeter leads to the motor terminals. The meter should indicate between 8 and 12  $\Omega$ .

# ! WARNING

## ELECTRICAL SHOCK HAZARD

Disconnect power before servicing.  
Replace all panels before operating.  
Failure to do so could result in death or electrical shock.

### BROIL ELEMENT

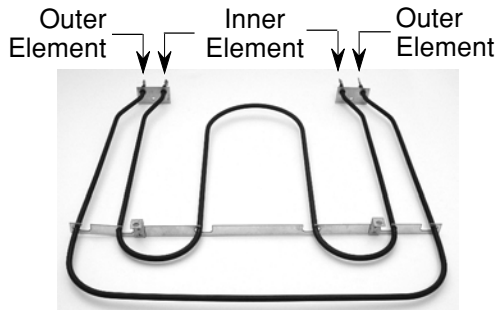

Refer to page 4-10 for the procedure for servicing the broil element.

1. Disconnect the electrical power to the oven.
2. Disconnect the wires from the broil element terminals.
3. Set the ohmmeter to the R x 1 scale.
4. Touch the ohmmeter leads to the **inner** broil element terminals. The meter should indicate between 45 and 55  $\Omega$ .
5. Touch the ohmmeter leads to the **outer** broil element terminals. The meter should indicate between 45 and 55  $\Omega$ .

# ! WARNING

## ELECTRICAL SHOCK HAZARD

Disconnect power before servicing.  
Replace all panels before operating.  
Failure to do so could result in death or electrical shock.

### BAKE ELEMENT

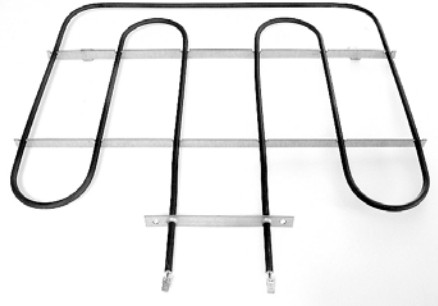

Refer to page 4-12 for the procedure for servicing the hidden bake element.

1. Disconnect the electrical power to the oven.
2. Disconnect the wires from the bake element terminals.
3. Set the ohmmeter to the R x 1 scale.
4. Touch the ohmmeter leads to the element terminals. The meter should indicate between 25 and 30  $\Omega$ .

# ! WARNING

## ELECTRICAL SHOCK HAZARD

Disconnect power before servicing.  
Replace all panels before operating.  
Failure to do so could result in death or electrical shock.

### OVEN DOOR LATCH ASSEMBLY

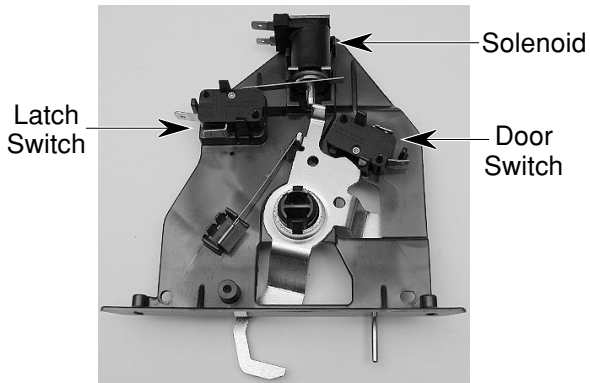

Refer to page 4-7 for the procedure for servicing the oven door latch assembly.

1. Disconnect the electrical power to the oven.
2. Disconnect the wires from the door latch assembly component under test.
3. Set the ohmmeter to the R x 1 scale.
4. **To test the solenoid**, touch the ohmmeter leads to the terminals. The meter should indicate between 47 and 54  $\Omega$ .
5. **To test the door or latch switch:**
  - a) Touch the ohmmeter leads to the following terminals (shown embossed on the switch). The meter should indicate:  
COM to N.O. = infinity (no continuity)  
COM to N.C. = 0  $\Omega$  (continuity)
  - b) Press the switch actuator button and touch the ohmmeter leads to the following terminals. The meter should indicate:  
COM to N.O. = 0  $\Omega$  (continuity)  
COM to N.C. = infinity (no continuity)

# ! WARNING

## ELECTRICAL SHOCK HAZARD

Disconnect power before servicing.  
Replace all panels before operating.  
Failure to do so could result in death or electrical shock.

### OVEN SHUTDOWN THERMAL FUSE

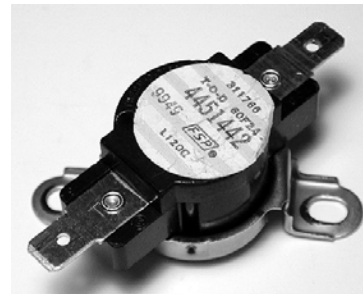

Refer to page 4-16 for the procedure for servicing the oven shutdown thermal fuse.

1. Disconnect the electrical power to the oven.
2. Disconnect the wires from the oven shutdown thermal fuse terminals.
3. Set the ohmmeter to the R x 1 scale.
4. Touch the ohmmeter leads to the oven shutdown thermal fuse terminals. The meter should indicate continuity (closed circuit).

# ! WARNING

## ELECTRICAL SHOCK HAZARD

Disconnect power before servicing.  
Replace all panels before operating.  
Failure to do so could result in death or electrical shock.

## OVEN LIGHT & CONTROL POWER TRANSFORMERS

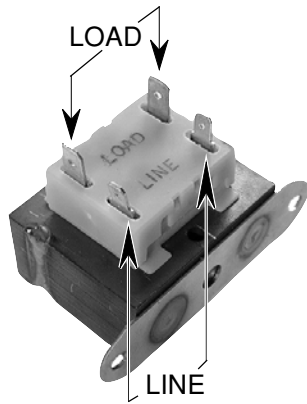

Refer to page 4-6 for the procedure for servicing the oven light & control power transformers.

1. Disconnect the electrical power to the oven.
2. Disconnect the wires from the transformer under test.
3. Set the ohmmeter to the R x 1 scale.
4. **To test the oven light transformer:**
  - a) Touch the ohmmeter leads to the LINE terminals. The meter should indicate between 40 and 45  $\Omega$ .
  - b) Touch the ohmmeter leads to the LOAD terminals. The meter should indicate less than 1  $\Omega$ .
5. **To test the control power transformer:**
  - a) Touch the ohmmeter leads to the LINE terminals. The meter should indicate between 85 and 90  $\Omega$ .
  - b) Touch the ohmmeter leads to the LOAD terminals. The meter should indicate between 1 and 6  $\Omega$ .

— NOTES —

# DIAGNOSIS & TROUBLESHOOTING

## DIAGNOSTICS

Before servicing, perform the following checks:

- The most common cause for control failure is corrosion on connectors. Therefore, disconnecting and reconnecting wires will be necessary throughout test procedures.
- All tests/checks should be made with a VOM or DVM having a sensitivity of 20,000 ohms-per-volt DC, or greater.
- Check all connections before replacing components, looking for broken or loose wires, failed terminals, or wires not pressed into connectors far enough.
- Voltage checks must be made with all connectors attached to the boards.
- Resistance checks must be made with power cord unplugged from outlet, and with wiring harness or connectors disconnected.
- Is the oven in the “Sabbath Mode”? If so, “SAB” will appear in the display. Press and hold the **6** touchpad for 5 seconds to end the Sabbath Mode.
- To check for the last five Fault codes: Press and hold the **0** touchpad to access the previous codes. Numeric touchpads 0 - 4 indicate faults 1 - 5 respectively, with “0” being the most recent code.

## FAHRENHEIT (°F) TO CELSIUS (°C) CONVERSION

The default is Fahrenheit (° F).

1. Press the BROIL pad for 5 seconds. The temperature will be displayed in degrees Celsius indicated by the “C” in the temperature display.
2. To return the display to degrees Fahrenheit press the BROIL pad again for 5 seconds. “F” will show in the temperature display.

## PROGRAMMING THE CAVITY SIZE

When replacing the electronic control, be sure to program the cavity size within 60 seconds of power up by pressing the following touchpads:

BAKE (upper half of BAKE touchpad),  
CONVECTION BROIL (lower half of BROIL touchpad).

STOP TIME, CONV FULL MEAL, digit #7,  
digit #9, TIMER SET/START, & START.

1. The size is shown in the display “-ID 24”.
2. Press the CLOCK SET/START touchpad until the correct size is displayed.
3. Press the CANCEL touchpad (do not press the OVEN START touchpad).
4. To verify programming, press and hold the **1** touchpad for 5 seconds.

## ELECTROSTATIC DISCHARGE (ESD) SENSITIVE ELECTRONICS

ESD problems are present everywhere. ESD may damage or weaken the electronic control assembly. The new control assembly may appear to work well after repair is finished, but failure may occur at a later date due to ESD stress.

- Use an anti-static wrist strap. Connect wrist strap to green ground connection point or unpainted metal in the appliance

-OR-

Touch your finger repeatedly to a green ground connection point or unpainted metal in the appliance.

- Before removing the part from it’s package, touch the anti-static bag to a green ground connection point or unpainted metal in the appliance.
- Avoid touching electronic parts or terminal contacts; handle electronic control assembly by edges only.
- When repackaging failed electronic control assembly in anti-static bag, observe above instructions.

## FAILURE/ERROR DISPLAY CODES

- Always disconnect the power to the unit before touching the internal parts of the oven.

- Upon replacement, immediately return the old electronic oven control. Use the mailing label that is supplied with each new control.

FAULT CODE	ERROR CODE	MEANING OF FAILURE CODE	RECOMMENDED REPAIR PROCEDURE
F0		Default F code — No failure	Will only be displayed if user presses and holds "0" key for 5 seconds and there are no pre-existing faults. Press CANCEL to clear display.
F1	All E Codes	Electronic control malfunction	Replace control.
F2	E0	Key held down too long, or key is shorted	<ol style="list-style-type: none"> <li>Check keypad connector for firm connection.</li> <li>Press CANCEL. If error code returns after 60 sec., replace keypad.</li> <li>Replace control.</li> </ol>
	E1	Keypad keytail not connected	
	E5	Cancel key drive line open	
F3	E0	Temperature sensor opened	<ol style="list-style-type: none"> <li>Check sensor connection.</li> <li>Measure sensor resistance (<math>1080\Omega</math> at <math>21^{\circ}\text{C}</math> [<math>70^{\circ}\text{F}</math>]; add <math>2\Omega</math> per degree). If resistance is not valid, replace sensor.</li> <li>If sensor resistance and connections are good, then the oven cavity temperature must have exceeded a safe level. Check for welded-closed relays on the control.</li> </ol>
	E1	Temperature sensor shorted	
	E2	Oven temp too high (over $301^{\circ}\text{C}$ [ $575^{\circ}\text{F}$ ] in Cook mode)	
	E3	Oven temp too high (over $510^{\circ}\text{C}$ [ $950^{\circ}\text{F}$ ] in Clean mode)	
F4	E1	Meat probe malfunction - shorted	<ol style="list-style-type: none"> <li>Disconnect meat probe and measure probe resistance: (<math>78\text{k}\Omega</math> at <math>15.6^{\circ}\text{C}</math> [<math>60^{\circ}\text{F}</math>]; <math>37\text{k}\Omega</math> at <math>32.2^{\circ}\text{C}</math> [<math>90^{\circ}\text{F}</math>]). If resistance is not valid, replace probe.</li> <li>Insert probe and check for a firm connection between probe and jack (in oven cavity).</li> <li>Check connection between jack and harness (in rear of oven).</li> </ol>
F5	E0	Door is open, but latch is locked (condition exists when door switch is closed indicating an open door, and latch switch is closed indicating a locked door)	<ol style="list-style-type: none"> <li>Check the latch assembly: <ul style="list-style-type: none"> <li>Check latch arm pivot joint, arm/solenoid connection, solenoid spring, and spring washer.</li> </ul> </li> <li>Check the Latch Solenoid: <ul style="list-style-type: none"> <li>Check for firm electrical connections.</li> <li>Disconnect the two wires from the solenoid and measure the resistance of the solenoid. A small resistance (approx. <math>175\Omega</math>) is normal. If the solenoid is open (<math>\infty\Omega</math>) or shorted (<math>0\Omega</math>) it should be replaced.</li> </ul> </li> <li>Check the Latch Switch: Disconnect it and use a continuity tester: <ul style="list-style-type: none"> <li>Door latched = switch closed, continuity should read <math>0\Omega</math>.</li> <li>Door unlatched = switch open, continuity should read <math>\infty\Omega</math>.</li> </ul> </li> <li>Check Door Open/Closed Switch. Disconnect it and use a continuity tester: <ul style="list-style-type: none"> <li>Door open = switch closed, continuity should read <math>0\Omega</math>.</li> <li>Door closed = switch open, continuity should read <math>\infty\Omega</math>.</li> </ul> </li> <li>Check power and element connections.</li> </ol>
	E1	Self clean latch will not lock	
	E5	Self clean temperature ( $288^{\circ}\text{C}$ [ $550^{\circ}\text{F}$ ]) not reached within 45 minutes	
	E7	Self clean latch will not unlock	
F6	E0	Return line not connected	If switch pulse return line is not connected, electronic control will display F6 within 60 seconds after power up. Replace control.



## CONTROL PANEL TEST LOCATIONS

COMPONENT	FRONT/REAR SERVICEABLE	CHECK POINTS	RESULTS
Door Switch	Front	P7-2 (BR) to P7-1 (TAN)	Door Open = Closed Circuit Door Closed = Open Circuit
Door Lock Solenoid (with Door Closed)	Front	P6-1 (Y) to P6-2 (W)	50 Ω
Oven Temperature Sensor	Front	P7-4 (V) to P7-6 (GN)	1080 Ω @ 21°C (70°F)
Blower	Rear	P1-5 (GY) to Neutral (W)	14 Ω to 18 Ω
Oven Light Transformer	Front	Primary Winding Secondary Winding	40 Ω to 45 Ω Less than 1 Ω
Oven Shutdown Thermal Fuse	Rear	P5-2 (OR) or P5-3 (R) to Red Wire at Terminal Block	Closed Circuit
Bake Element	Rear	P5-3 (R) to Red Wire at Terminal Block	25 Ω to 30 Ω
Inner Broil Element	Front	P5-2 (OR) to Red Wire at Terminal Block	45 Ω to 55 Ω
Outer Broil Element	Front	P5-1 (BU) to Red Wire at Terminal Block	45 Ω to 55 Ω
Convection Ring Element	Front	P5-4 (Y) to Red Wire at Terminal Block	28 Ω to 35 Ω
Convection Fan Motor	Rear	P1-6 (OR) to Neutral (W)	8 Ω to 12 Ω
Meat Probe Jack	Rear	P7-7 (GN) to P7-8 (Y)	Probe into Jack - Check for 78k Ω @ Room Temperature
Latch Switch	Front	P7-3 (BU) to P7-1 (TAN)	Door Unlocked = Open Circuit Door Locked = Closed Circuit

## RELAY LOGIC CHART

MODES	RELAYS	BAKE	IN BR	OUT BR	** CONV ELEM	** CONV FAN	OV LT	BLOWER
OFF	○	○	○	○	○	⊗	⊗	⊗
■ PREHEAT-BAKE	+	+	+	○	○	⊗	⊗	X
BAKE 24",30" ■	+	+	+	○	○	⊗	⊗	X
BAKE 27" ■	+	+	+	○	○	⊗	⊗	X
ECONO BROIL	○	X	○	○	○	⊗	⊗	X
MAXI BROIL	○	X	X	○	○	⊗	⊗	X
CONV BROIL	○	X	X	○	X	⊗	⊗	X
● PREHEAT-CONV	+	+	+	○	X	⊗	⊗	X
CONV ROAST 24" ●	X	○	X	○	X	⊗	⊗	X
CONV ROAST 27",30" ●	X	+	X	○	X	⊗	⊗	X
CONV BAKE 24" ●	○	○	○	+	X	⊗	⊗	X
CONV BAKE 27" ●	○	○	○	X	X	⊗	⊗	X
CONV BAKE 30" ●	+	○	○	X	X	⊗	⊗	X
▲ PREHEAT-CLEAN	+	+	+	○	○	○	○	X
CLEAN ▲	X	+	+	○	○	○	○	X
PREHEAT DEHYDRATE	○	○	○	+	X	⊗	⊗	X
DEHYDRATE	○	○	○	X	X	⊗	⊗	X
PREHEAT-BREAD	○	○	○	+	X	⊗	⊗	X
RAISING BREAD	○	○	○	+	X	⊗	⊗	X

### RELAY LOGIC KEY

○ - OFF

X - ON

+- CYCLING (MAX PERIOD = 60SEC)

⊗ - ON OR OFF

\*\* Thermal Convection Models Only

— NOTES —

# WIRING DIAGRAM & STRIP CIRCUITS

## MODEL NUMBER / TECH SHEET USE

MODEL NUMBER	TECH SHEET NUMBER
KEBI141D**6	4452023
KEBS147D**6	4452024
KEBI171D**6	4452023
KEBI177D**6	4452024
KEBI101D**6	4452023
KEBI107D**6	4452024
KEBC177D**6	4451876D
KEBC107D**6	
KEBI141D**7	
KEBI141D**8	
KEBI141D**9	
KEBI141D**10	
KEBI141D**11	
KEBI141D**12	
KEBS147D**7	
KEBS147D**8	
KEBS147D**9	
KEBS147D**10	
KEBS147D**11	
KEBS147D**12	
KEBI171D**7	
KEBI171D**8	
KEBI171D**9	
KEBI171D**10	
KEBI171D**11	
KEBI171D**12	
KEBS177D**7	
KEBS177D**8	
KEBS177D**9	
KEBS177D**10	
KEBS177D**11	
KEBS177D**12	
KEBI101D**7	
KEBI101D**8	
KEBI101D**9	
KEBI101D**10	
KEBI101D**11	
KEBI101D**12	
KEBS107D**7	
KEBS107D**8	
KEBS107D**9	
KEBS107D**10	
KEBS107D**11	
KEBS107D**12	

# SCHEMATIC DIAGRAM

## WIRE HARNESS SCHEMATIC

### NOTES:

- When replacing the electronic control, be sure to program the cavity size (see "Programming The Cavity Size" on page 6-1).
- Dots indicate connections or splices.
- Circuit shown in STANDBY/OFF mode with oven door closed.

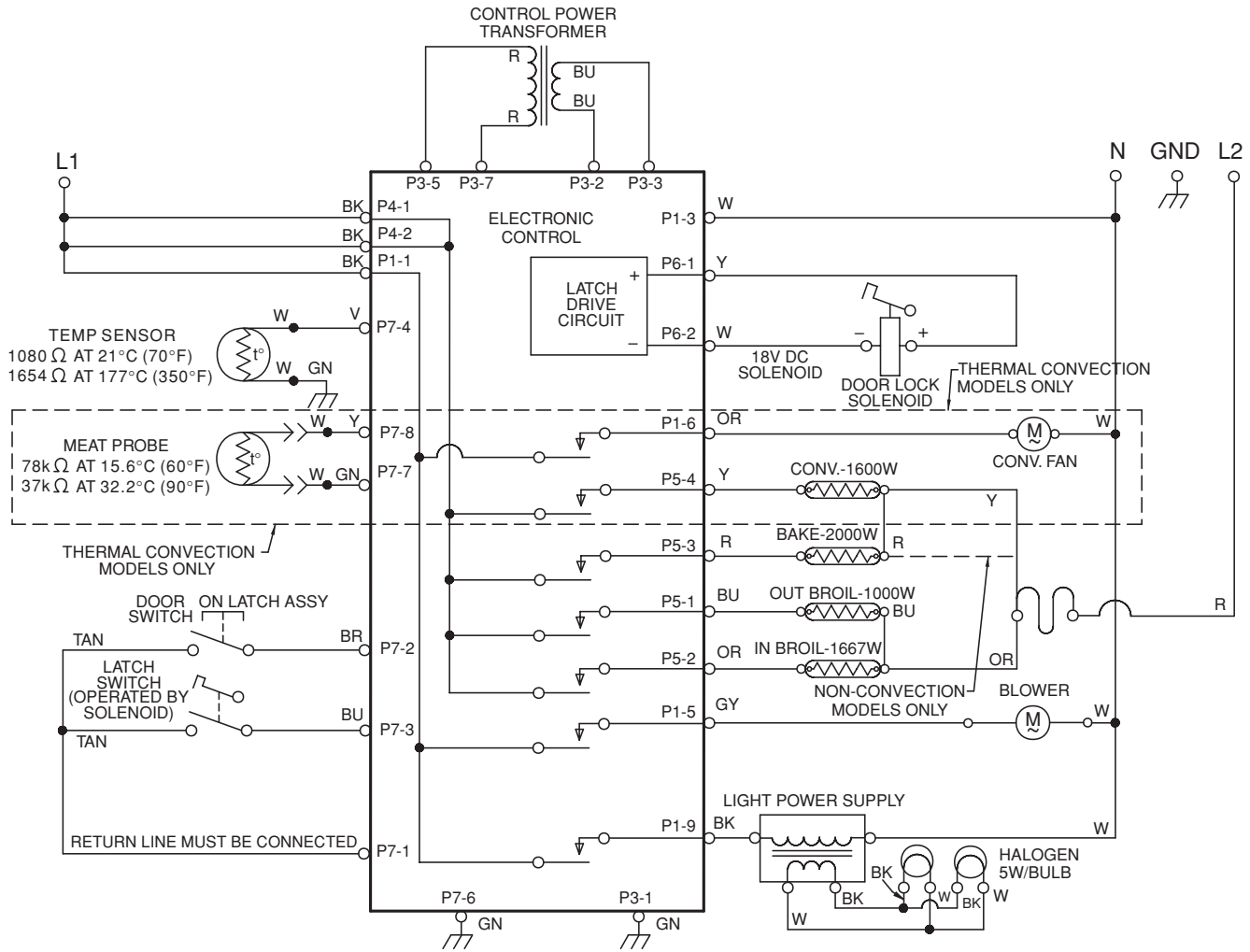
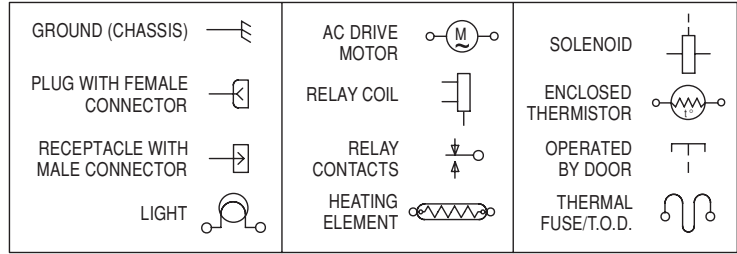

**PART NO. 4451876 REV. D**

### ELECTRONIC CONTROL PINOUTS

PIN	FUNCTION	COLOR
P6-1	LATCH SOLENOID (+)	Y
P6-2	LATCH SOLENOID (-)	W
P6-3	NOT CONNECTED	
P6-4	NOT CONNECTED	
P6-5	NOT CONNECTED	
P6-6	NOT CONNECTED	

PIN	FUNCTION	COLOR
P7-1	SWITCH COMMON (STROBE)	TAN
P7-2	DOOR SWITCH	BR
P7-3	LATCH SWITCH	BU
P7-4	TEMP SENSOR	V
P7-5	NOT CONNECTED	
P7-6	GROUND	GN
P7-7	MEAT PROBE SENSOR (GRND)	GN
P7-8	MEAT PROBE SENSOR	Y

# STRIP CIRCUITS

## BAKE & PREHEAT-BAKE

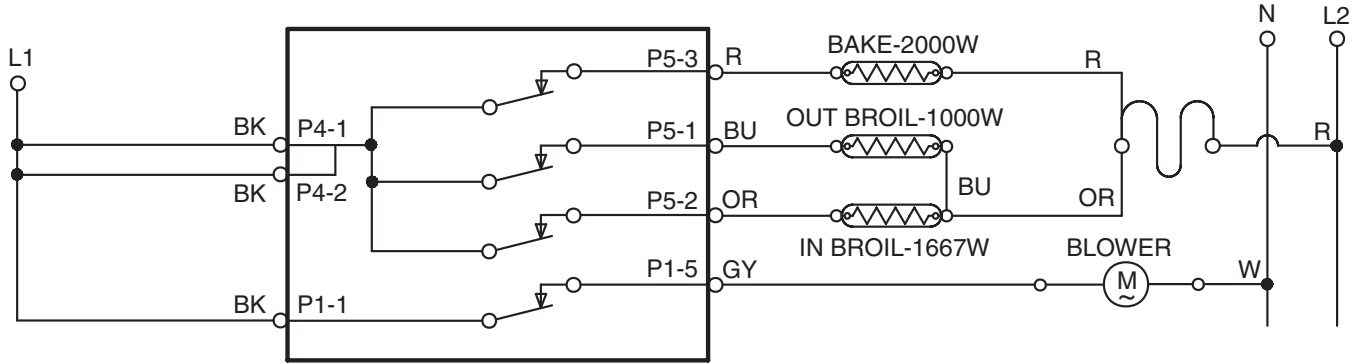

## ECONO BROIL

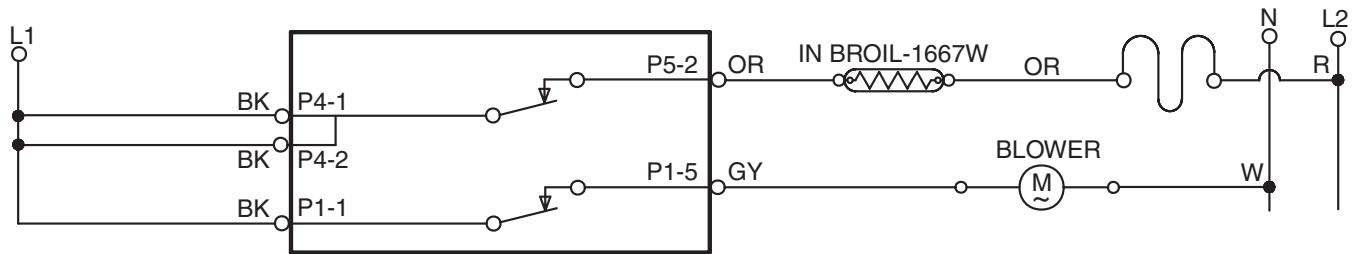

## MAXI BROIL

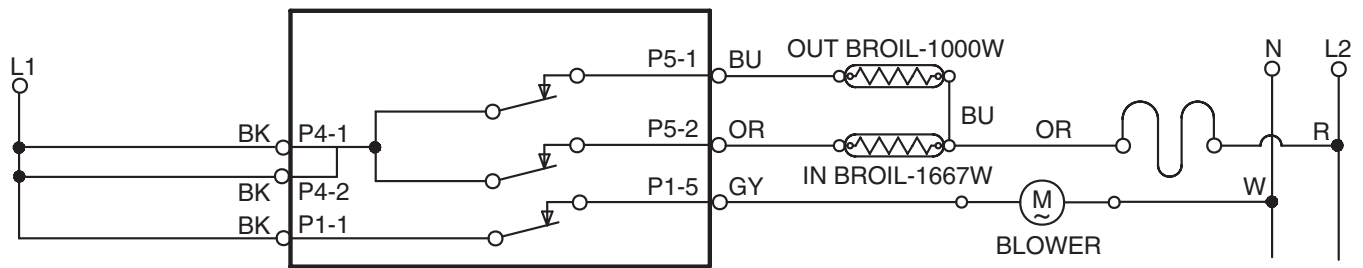

**CONVECTION BROIL  
(THERMAL CONVECTION MODELS ONLY)**

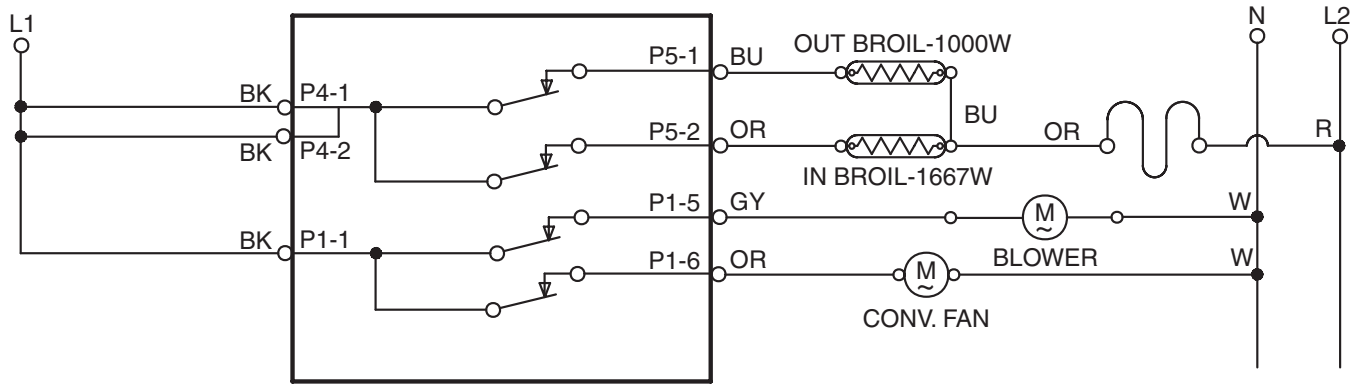

**CONVECTION ROAST & PREHEAT-CONVECTION BAKE  
(THERMAL CONVECTION MODELS ONLY)**

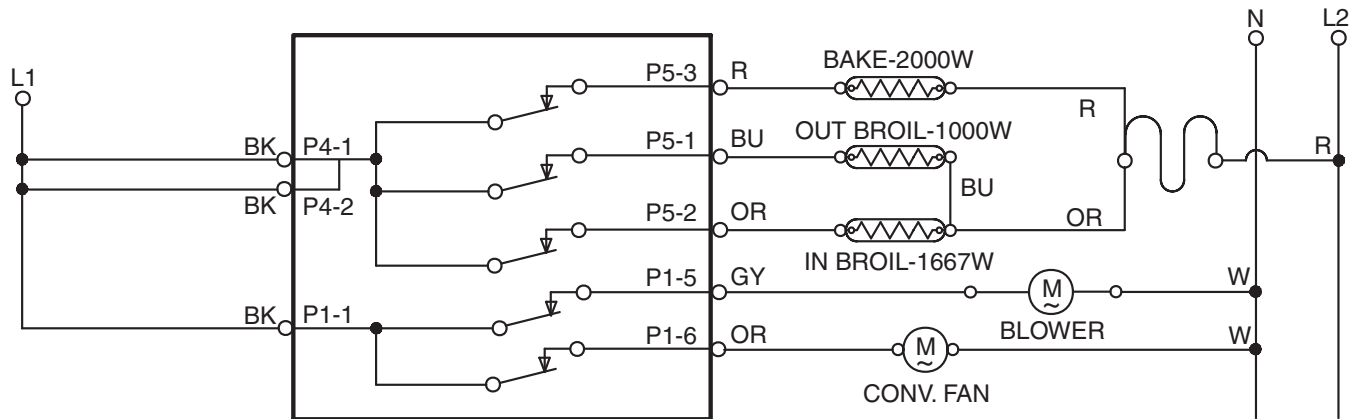

**CONVECTION BAKE  
(THERMAL CONVECTION MODELS ONLY)**

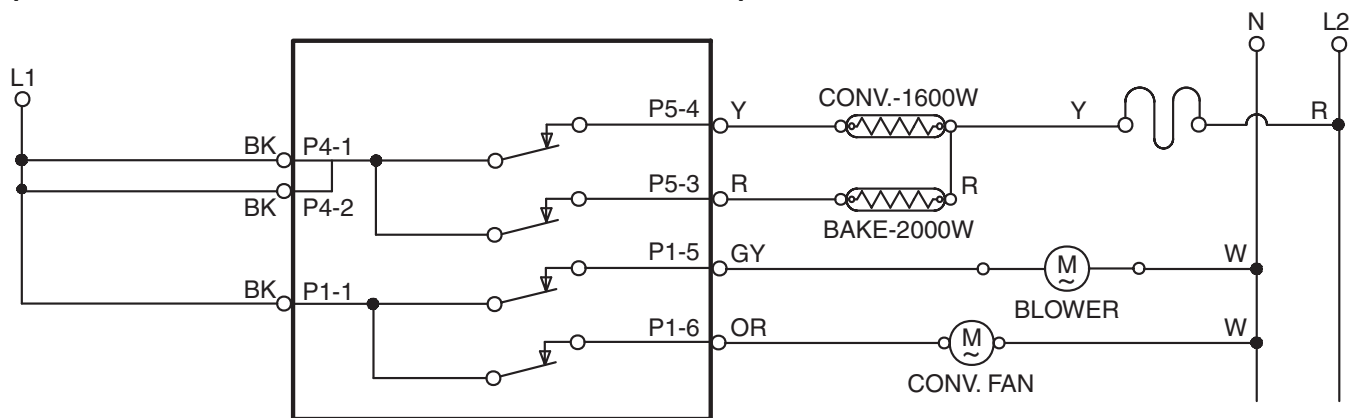

# CLEAN

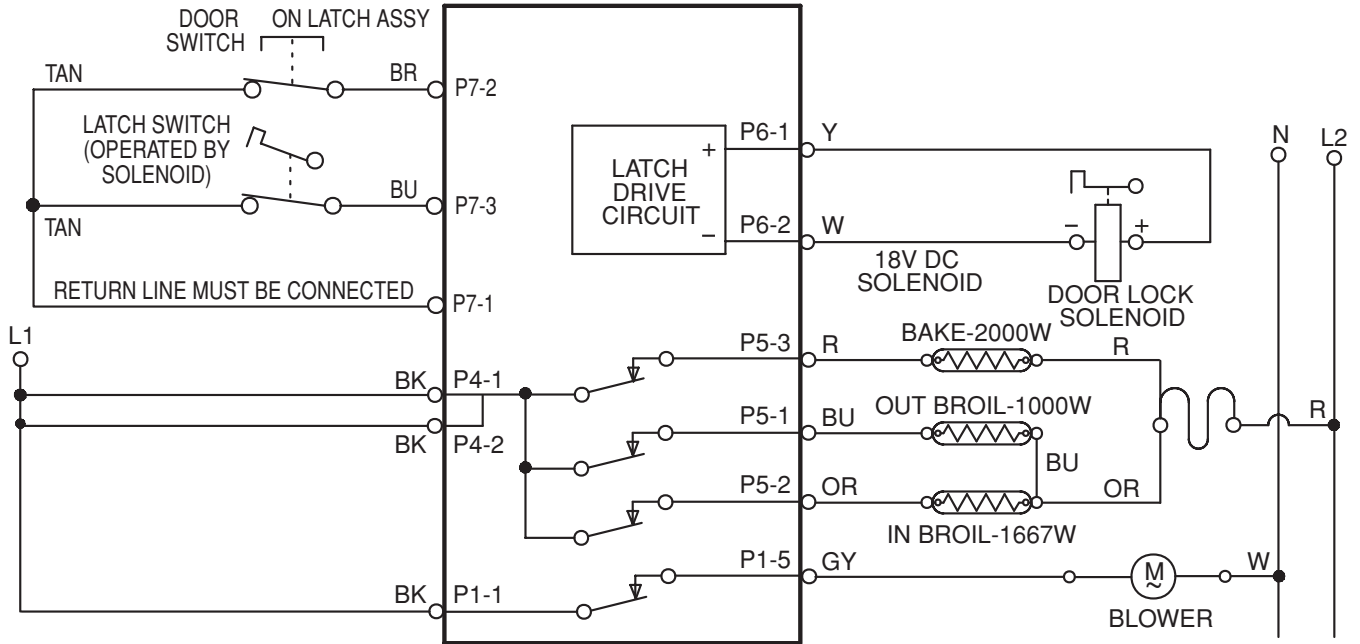

— NOTES —



— NOTES —

— NOTES —

# **PRODUCT SPECIFICATIONS AND WARRANTY INFORMATION SOURCES**

**IN THE UNITED STATES:**

**FOR PRODUCT SPECIFICATIONS AND WARRANTY INFORMATION CALL:**

FOR WHIRLPOOL PRODUCTS: 1-800-253-1301  
FOR KITCHENAID PRODUCTS: 1-800-422-1230  
FOR ROPER PRODUCTS: 1-800-447-6737

**FOR TECHNICAL ASSISTANCE WHILE AT THE CUSTOMER'S HOME CALL:**

THE TECHNICAL ASSISTANCE LINE: 1-800-253-2870

**HAVE YOUR STORE NUMBER READY TO IDENTIFY YOU AS AN  
AUTHORIZED SERVICER**

**FOR LITERATURE ORDERS:**

PHONE: 1-800-851-4605

---

**IN CANADA:**

**FOR PRODUCT SPECIFICATIONS AND WARRANTY INFORMATION CALL:**

1-800-461-5681

**FOR TECHNICAL ASSISTANCE WHILE AT THE CUSTOMER'S HOME CALL:**

THE TECHNICAL ASSISTANCE LINE: 1-800-488-4791

**HAVE YOUR STORE NUMBER READY TO IDENTIFY YOU AS AN  
AUTHORIZED SERVICER**

**KitchenAid®**  
FOR THE WAY IT'S MADE.®

