

Service

This manual is to be used by qualified appliance technicians only. Maytag does not assume any responsibility for property damage or personal injury for improper service procedures done by an unqualified person.

Vent Hoods

This Base Manual covers general information
Refer to individual Technical Sheet
for information on specific models

This manual includes, but is
not limited to the following:

JXT5830ADB/W/S

JXT5836ADB/W/S

JXT6030ADS

JXT6036ADS

JXT8030ADS

JXT8036ADS

JXT8042ADS

JXT8136ADS

JXT8142ADS

JXT9030CDP

JXT9036CDP

JXT9048CDP

JXT9130CDP

JXT9136CDP

Important Information

Pride and workmanship go into every product to provide our customers with quality products. It is possible, however, that during its lifetime a product may require service. Products should be serviced only by a qualified service technician who is familiar with the safety procedures required in the repair and who is equipped with the proper tools, parts, testing instruments and the appropriate service information. **IT IS THE TECHNICIANS RESPONSIBILITY TO REVIEW ALL APPROPRIATE SERVICE INFORMATION BEFORE BEGINNING REPAIRS.**

Important Notices for Servicers and Consumers



WARNING

To avoid risk of severe personal injury or death, disconnect power before working/servicing on appliance to avoid electrical shock.

To locate an authorized servicer, please consult your telephone book or the dealer from whom you purchased this product. For further assistance, please contact:

Customer Service Support Center

CAIR Center

Web Site

Telephone Number

WWW.JENNAIR.COM 1-800-688-1100

CAIR Center in Canada 1-800-688-2002

Recognize Safety Symbols, Words, and Labels



DANGER

DANGER—Immediate hazards which **WILL** result in severe personal injury or death.



WARNING

WARNING—Hazards or unsafe practices which **COULD** result in severe personal injury or death.



CAUTION

CAUTION—Hazards or unsafe practices which **COULD** result in minor personal injury, product or property damage.

Table of Contents

Important Information	2	Disassembly Procedures for Models JXT9030CDP, JXT9036CDP, JXT9048CDP, JXT9130CDP, JXT9136CDP	
Important Safety Information			
In Case of Fire	4	Halogen Light Removal	13
Safety Practices for Servicer	4	Heat Lamp Removal	13
Servicing	4	Grease Filter/Grease Filtger Cover Removal	13
Electrical Requirements	5	Halogen Light Socket	13
Extension Cord	5	Heat Lamp Socket Removal	13
Receiving Vent Hood	5	Light Panel Removal	14
Precautions	5	Control Board Removal	14
Using the Vent Hood	5	Touch Pad Removal	14
General Information		Capacitor Removal	14
Cooking Nomenclature	6	Transformer Removal	15
Specifications	7	Blower Motor Removal	15
Placement of the Vent Hood	7	Filter Spring Clip Removal	15
Do Not Block Air Vents	7	Disassembly Procedures for Models JXT8042ADS, JXT8142ADS, JXT58309AD*, JXT5836AD*	
Location of Model Number	7	Halogen Light Removal	16
Grounding Instructions	7	Grease Filter/Grease Filtger Cover Removal	16
Model Identification	7	Halogen Light Socket	16
Service	7	Control Board Removal	16
Parts and Accessories	7	Control Panel Removal	17
Extended Service Plan	7	Blower Motor Removal	17
Vent Hood Description	8	Capacitor Removal	17
Troubleshooting Procedures	9	Filter Spring Clip Removal	17
Testing Procedures	11	Appendix A: Installation Instructions	
		JXT5830AD*, JXT5836AD*	A-2
		JXT8030ADS, JXT8036ADS, JXT8048ADS	A-4
		JXT8136ADS, JXT8142ADS	A-6
		JXT9030CDP, JXT9036CDP, JXT9048CDP	A-8
		JXT9130CDP, JXT9136CDP	A-10
		Appendix B: Controls and Features	
		JXT5830AD*, JXT5836AD*, JXT8030ADS, JXT8036ADS, JXT8048ADS, JXT8136ADS, JXT8142ADS	B-2
		JXT9030CDP, JXT9036CDP, JXT9048CDP, JXT9130CDP, JXT9136CDP	B-5
		Care and Cleaning	B-6

Important Safety Information

Recognize this symbol as a safety precaution.



WARNING

If the information in this manual is not followed exactly, a fire or explosion may result causing property damage, personal injury or death.

There can be a risk of injury or electrical shock while performing services or repairs. Injury or electrical shock can be serious or even fatal. Consequently, extreme caution should be taken when performing voltage checks on individual components of a product. The electrical power supply should ALWAYS be disconnected when servicing a product.

This appliance must be properly grounded. Never plug in or direct-wire an appliance unless it is properly grounded and in accordance with all local and national codes. See "Installation Instructions" that accompany the product for the appropriate grounding procedures.

WARNING

To avoid risk of electrical shock, property damage, personal injury or death; verify wiring is correct, if components were replaced. Verify proper and complete operation of unit after servicing.

This appliance contains or produces a chemical or chemicals which are known to the state of California to cause cancer, birth defects or other reproductive harm. To reduce the risk from substances in the fuel or from fuel combustion, make sure this appliance is installed, operated, and maintained according to the instructions in this manual.



WARNING

In Case of Fire

Fires can occur as a result of over cooking or excessive grease. Though a fire is unlikely, proceed as follows:

Surface Element Fires

1. Smother fire with a nonflammable lid/baking soda, or use a Class ABC or BC extinguisher. Not water, salt or flour.
2. As soon as it is safe to do so, turn the surface controls to "OFF."

Oven Fires

1. Do not open the oven door.
2. Turn all range/oven controls to the OFF position.
3. As an added precaution turn off oven/range electricity at the main circuit breaker or fuse box.
4. Turn on vent hood to remove smoke.
5. Allow the food or grease to burn itself out in the oven.
6. If smoke and fire persist, call the local fire department.
7. If there is any damage to components, call an authorized servicer before using the vent hood.

To avoid risk of property damage or personal injury, do not obstruct the flow of ventilation air to the vent hood.

To avoid risk of electrical shock, serious personal injury or death: Verify the vent hood has been properly grounded and always disconnect the electrical supply before servicing this unit.

Safety Practices for Servicer

Safe and satisfactory operation of vent hoods depends upon its design and proper installation.

Servicing

Listed below are some general precautions and safety practices which should be followed in order to protect the service technician and consumer during service and after service has been completed.

1. **Check vent hood when service is complete**—After servicing, make visual checks on electrical connection. Inform consumer of the condition of vent hood before leaving.
2. **Adhere to all local regulations and codes when performing service.**

Important Safety Information

Electrical Requirements

120-volt, 60 Hertz, 40 amp, individual circuit which is properly grounded, polarized and protected by a circuit breaker or fuse.

Extension Cord

Due to possible pinching during installation, extension cords should not be used on products.

Receiving the Vent Hood

- Authorized servicer must install the vent hood, in accordance with the Installation Instructions.
- Adjustments and service should be performed only by authorized servicer.
- Plug vent hood into a 120-volt grounded outlet only.
- Do not remove round grounding prong from the plug. If in doubt about grounding of the home electrical system, it is consumers responsibility and obligation to have an ungrounded outlet replaced with a properly grounded three-prong outlet in accordance with the National Electrical Code.
- Do not use an extension cord with this vent hood.
- Insure all packing materials are removed from the vent hood before operating.
- Clean grease and dirt from existing duct work to prevent future fires.
- Check all joints on duct work to ensure proper connection; all joints should be taped properly.

Precautions

- When cutting or drilling into walls or ceilings, do not damage electrical wiring and other hidden utilities.
- Ducted fans must always be vented to the outdoors.
- Clean vent hood frequently. Grease should not be allowed to accumulate on hood or filter.
- When flaming foods under the hood, turn the fan off. The fan, if operating, may spread the flame.
- Do not mix household cleaning products. Chemical mixtures may interact with hazardous results.

Using the Vent Hood

- Do not allow anyone to climb, stand or hang on the vent hood. They could damage the vent hood and cause severe personal injury.
- Saturation of greasy residue in the blower and filters may cause increased flammability. Keep vent hood clean and free of grease and residue build-up at all times to prevent possible fires.
- Filters must be cleaned periodically and kept free from accumulation of cooking residue.
- Old and worn filters must be replaced immediately.
- Do not operate blowers when filters are removed.
- Do not disassemble parts (for cleaning) without proper instructions. Contact the Service Center for removal instructions at (800) 536-6247.
- Do not use water on grease fires.
- Do not let grease or other flammable materials collect in or around the vent hood.
- Do not repair or replace any part of the vent hood unless it is recommended in this manual.
- Keep vent hood ducts unobstructed.



CAUTION

Do not store items of interest to children in cabinets above the vent hood. Children may climb on the vent hood to reach these items and may become seriously injured.

General Information

This manual provides basic instructions and suggestions for handling, installing and servicing electric vent hoods.

The directions, information, and warnings in this manual are developed from experience and careful testing of the product. If the unit is installed according to this manual, it will operate properly and will require minimal servicing. A unit in proper operating order ensures the consumer all the benefits provided by the electric vent hood.

This manual contains information needed by authorized service technicians to install and service electric vent hoods. There may be, however, some parts which need further explanation. Refer to the Installation Instructions, Use and Care, Technical Sheets or the toll-free technical support line.

Cooking Nomenclature

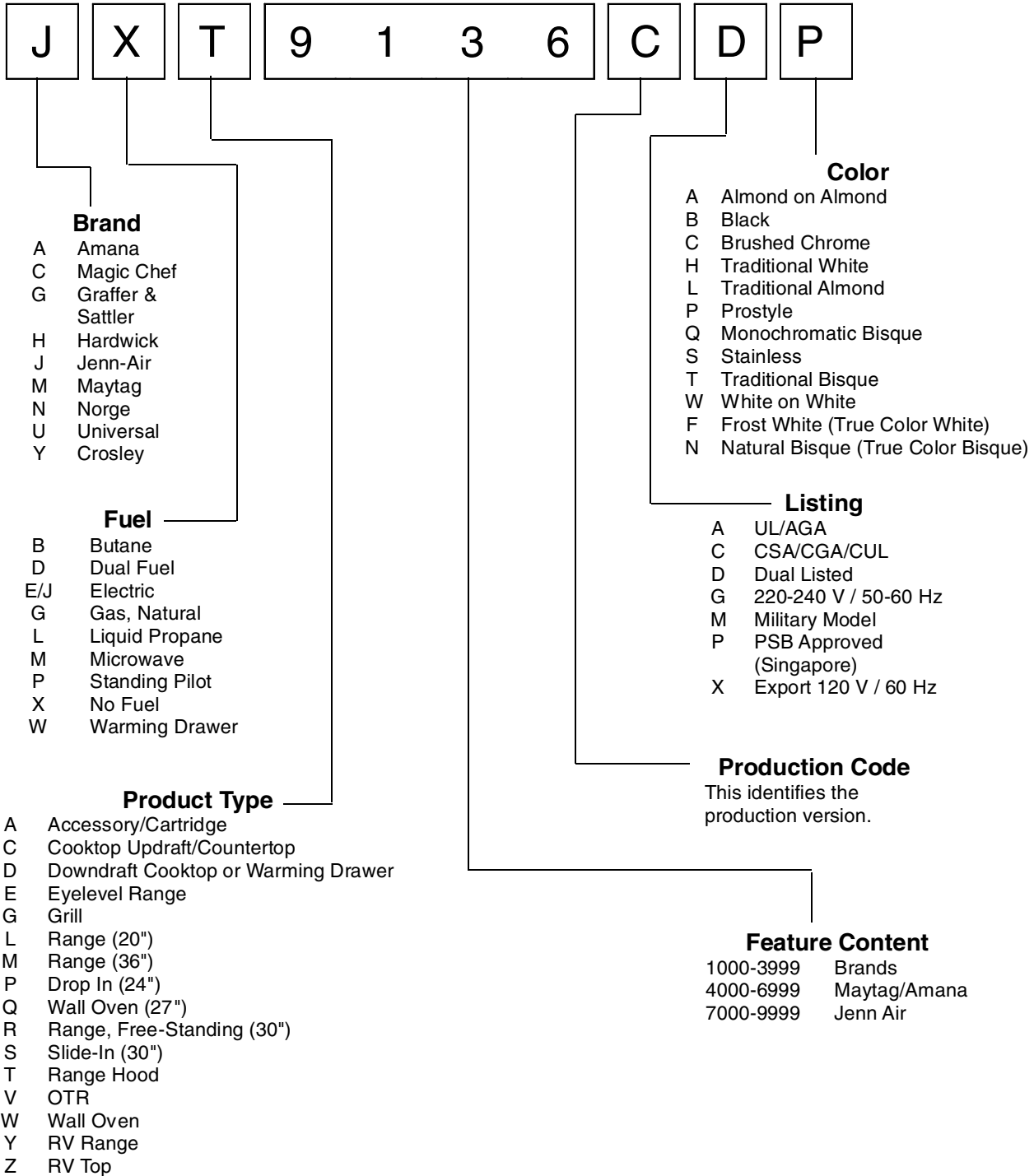

General Information

Specifications

Refer to individual Technical Sheet for specification information.

Placement of the Vent Hood

This electric vent hood must be placed in the kitchen or comparable room. All safety guidelines must be followed (see Chapter 2) and free air flow around the vent hood is essential.

Do Not Block Air Vents

All air vents must be kept clear during cooking. If air vents are covered during operation, the vent hood may overheat.

Location of Model Number

To request service information or replacement parts, the service center will require the model number of your vent hood. This number can be found inside or under the vent hood shroud.

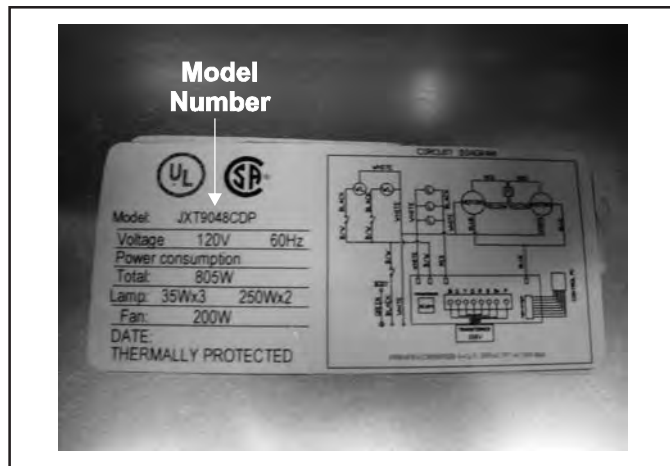

Grounding Instructions

This vent hood must be grounded. If an electrical short circuit occurs, grounding reduces the risk of electric shock by providing an escape wire for the electric current. The cord for this vent hood has a grounding wire with a grounding plug. Put the plug into an outlet that is properly installed and grounded.



WARNING

To avoid risk of electric shock, personal injury or death, use grounding plug properly.

Ask a qualified electrician if you do not understand the grounding instructions or if you wonder whether the vent hood is properly grounded.

Keep the electrical power cord dry and do not pinch or crush it in any way.

For a permanently connected vent hood: This vent hood must be connected to a grounded, metallic, permanent wiring system, or an equipment grounding conductor should be run with the circuit conductors and connected to the equipment grounding terminal or lead on the appliance.



WARNING

Attaching adapter ground terminal to wall receptacle cover screw does not ground the vent hood unless the cover screw is metal and not insulated, and wall receptacle is grounded through the house wiring. Consumer should have circuit checked by a qualified electrician to verify receptacle is properly grounded.

Model Identification

Complete enclosed registration card and promptly return. If registration card is missing:

- For Jenn-Air product call 1-800-688-1100 or visit the Web Site at www.jennair.com
- For product in Canada call 1-866-587-2002 or visit the Web Site at www.jennair.com

When contacting provide product information located on rating plate. Record the following:

Model Number: _____

Manufacturing Number: _____

Serial or S/N Number: _____

Date of purchase: _____

Dealer's name and address: _____

Service

Keep a copy of sales receipt for future reference or in case warranty service is required. To locate an authorized servicer:

- For Jenn-Air product call 1-800-688-1100 or visit the Web Site at www.jennair.com
- For product in Canada call 1-866-587-2002 or visit the Web Site at www.jennair.com

Warranty service must be performed by an authorized servicer. We also recommend contacting an authorized servicer, if service is required after warranty expires.

Parts and Accessories

Purchase replacement parts and accessories over the phone. To order accessories for your product call:

- For Jenn-Air product call 1-800-688-1100 or visit the Web Site at www.jennair.com
- For product in Canada call 1-866-587-2002 or visit the Web Sites at www.amana.com or www.maytag.com

Extended Service Plan

We offer long-term service protection for this new oven.

- Dependability PlusSM Extended Service Plan is specially designed to supplement Jenn-Air's strong warranty. This plan covers parts, labor, and travel charges.

Call 1-800-925-2020 for information.

Range Description

Vent Hood Description

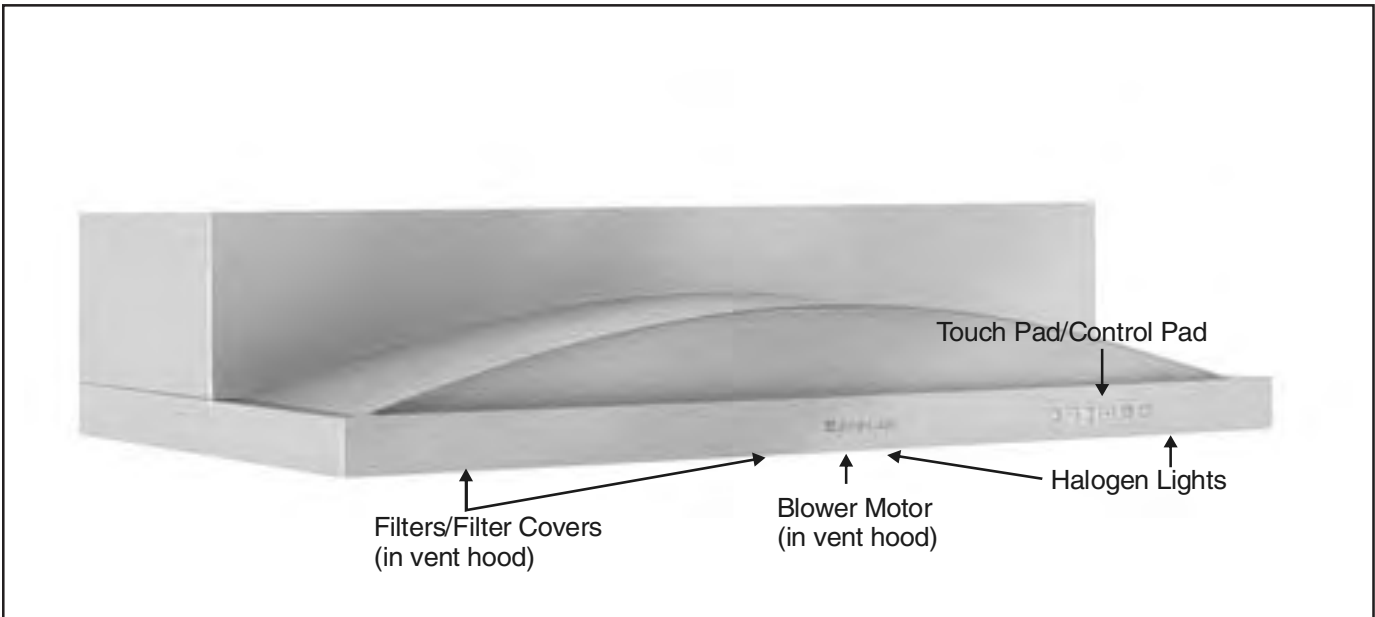
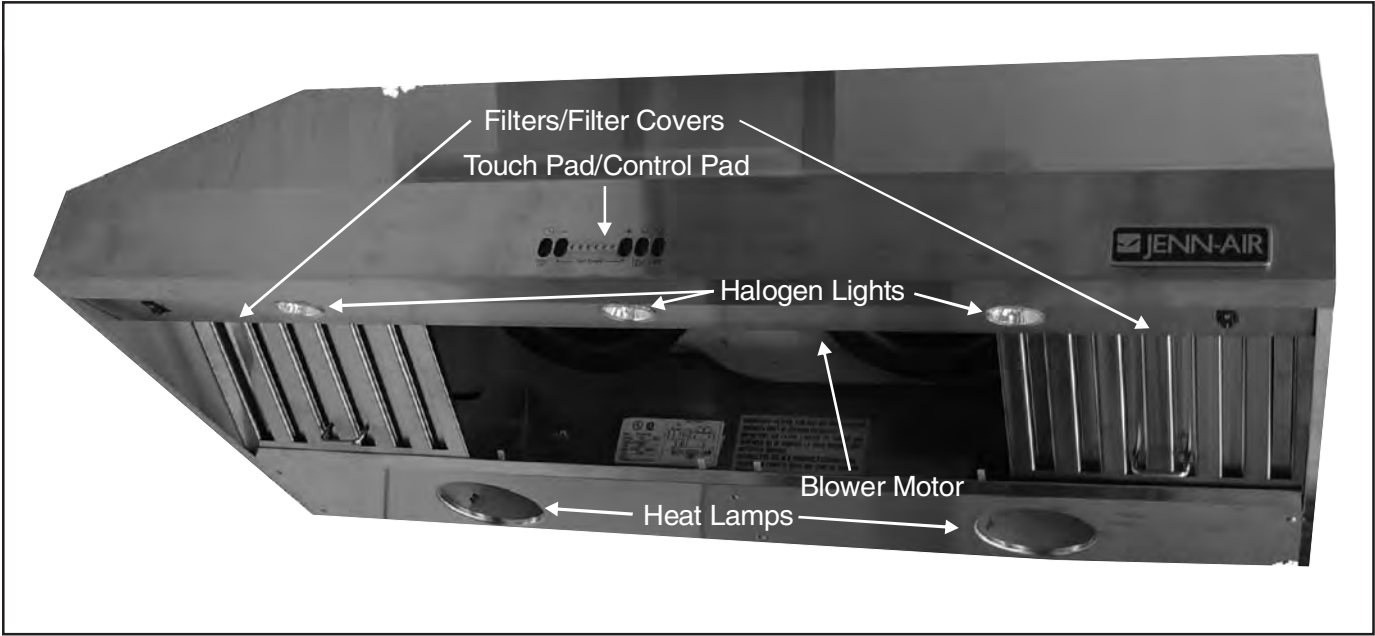

Troubleshooting Procedures



WARNING

To avoid risk of electrical shock, personal injury, or death, disconnect power to vent hood before servicing, unless testing requires power.

Problem	Possible Cause	Correction
Blower motor will not operate, lights will not illuminate	No input power Circuit breaker tripped Black/white or white wires loose at control board, no wires connected to control board... Control board defective Touch pad/control panel defective	<ul style="list-style-type: none"> • Verify 120 VAC is present at unit. • Verify circuit breaker isn't tripped. • Verify all connections are tight. • Perform control board test. • Perform touch pad or control panel test.
Blower motor will not operate (Lights illuminate)	Blue wire loose on control board Blower motor seized..... Blower motor defective..... Capacitor damaged or defective Touch pad or control panel defective Blower motor too hot and has been shut down by the thermal protection system.....	<ul style="list-style-type: none"> • Verify blue wire is connected and tight on control board. • Verify blower is free from obstructions and rotates freely. • Perform blower motor test. • Perform capacitor test. • Perform touch pad or control panel test. • Allow blower motor to cool.
Blower motor starts slow and will not operate at full speed (Lights illuminate)	Capacitor shorted or defective Blower motor defective..... Control board defective Touch pad or control panel defective Obstructions in blower motor	<ul style="list-style-type: none"> • Perform capacitor test. • Perform blower motor test. • Perform control board test. • Perform touch pad or control panel test. • Verify blower motor is free from obstructions and rotates freely.
Blower motor operates, but cannot change fan speed (Lights illuminate)	Capacitor shorted or defective Blower motor defective..... Touch pad or control panel defective Obstructions in blower motor	<ul style="list-style-type: none"> • Perform capacitor test. • Perform blower motor test. • Perform touch pad or control panel test. • Verify blower motor is free from obstructions and rotates freely.
Lights will not illuminate (Blower motor operates)	Light bulb(s) burnt out Light bulb not making contact with socket Red wire loose on control board Touch pad or control panel defective Light socket defective.....	<ul style="list-style-type: none"> • Replace bulb(s). • Remove power to unit, remove light bulb and bend the two metal brackets inside the bulb opening (bend outwards). This lowers the light socket. • Verify red wire is connected and tight on control board. • Perform touch pad or control panel test. • Perform halogen light test.
Lights illuminate at full brightness only (Blower motor operates)	Loose wires to lights/control board..... Light socket defective..... Control board defective Control panel defective Touch pad or control panel defective	<ul style="list-style-type: none"> • Verify wires are connected and tight at light socket/control board. • Perform halogen light test. • Perform control board test. • Replace control panel. • Perform touch pad or control panel test.

Troubleshooting Procedures



To avoid risk of electrical shock, personal injury, or death, disconnect power to vent hood before servicing, unless testing requires power.

Problem	Possible Cause	Correction
Lights illuminate at half brightness only (Blower motor operates)	Loose wires to lights/control board..... Light socket defective Control board defective Control panel defective..... Touch pad or control panel defective	<ul style="list-style-type: none"> • Verify wires are connected and tight at light socket/control board. • Perform halogen light test. • Perform control board test. • Perform control panel test. • Perform touch pad or control panel test.
Vent hood vibrates when operating blower motor	Blower motor loose..... Blower motor wheel damaged..... Vent hood not securely fastened.....	<ul style="list-style-type: none"> • Tighten blower motor. • Replace blower motor wheel. • Verify vent hood installation; tighten as necessary.
Metal filter vibrates when operating blower motor	Metal filter loose Broken clip.....	<ul style="list-style-type: none"> • Tighten or change metal filter. • Replace the clip.
Display will not illuminate	No input power Circuit breaker tripped Loose wire connection or broken wire..... Control board defective Touch pad or control panel defective	<ul style="list-style-type: none"> • Verify 120 VAC is present at unit. • Verify circuit breaker isn't tripped. • Verify all connections are clean and tight, wires are not broken. • Verify voltage is present. If so, perform control board test. • Perform touch pad or control panel test.
Heat lamp will not illuminate	Heat lamp bulb defective..... No input power Circuit breaker tripped Loose wire connection or broken wire..... Touch pad or control panel defective	<ul style="list-style-type: none"> • Replace heat lamp bulb. • Verify 120 VAC is present at unit. • Verify circuit breaker isn't tripped. • Verify all connections are clean and tight, wires are not broken. • Perform touch pad or control panel test.
Dim display	Loose wire connection or broken wire..... Control board requires a reset..... Control board defective Touch pad or control panel defective	<ul style="list-style-type: none"> • Verify all connections are clean and tight, wires are not broken. • Disconnect power to unit for 15 minutes. If still dim, replace the control board. • Verify voltage is present. If so, test control board. • Perform touch pad or control panel test.
Any one single function on control panel does not operate	Touch pad or control panel defective	<ul style="list-style-type: none"> • Perform touch pad or control panel test.
Vent hood not venting properly	Vent hood not close enough to cooktop..... Open doors/windows affecting air flow..... Ductwork clogged or blocked Duct opening restricted Ductwork too small.....	<ul style="list-style-type: none"> • Verify distance between hood and cooktop (24-32 inches). • Close all nearby doors and windows. • Clean the ductwork. • Adjust the duct opening direction. • Increase size of ductwork.

Testing Procedures



WARNING

To avoid risk of electrical shock, personal injury or death; disconnect power to vent hood before servicing, unless testing requires power.

Model Numbers	Component	Test Procedure	Results
All	Halogen lights	Press light switch once (measure voltage at light socket) Press light switch again (measure voltage at light socket) Press light switch once (measure voltage at light socket) Press and hold light switch for 3 seconds... (measure voltage at light socket)	Lights illuminate to full brightness (120 VAC). Lights extinguish (turn off) (0 VAC). Lights illuminate to full brightness (120 VAC). Lights illuminate to half brightness (63 VAC)
All	Halogen light socket	Remove one wire from receptacle and test resistance of terminals..... Measure voltage at light	Indicates continuity with bulb screwed in. 120 VAC. If no voltage is present at light, check wiring or light switches.
JXT9030CDP, JXT9036CDP, JXT9048CDP, JXT9130CDP, JXT9136CDP	Heat lamp socket	Remove one wire from receptacle and test resistance of terminals..... Measure voltage at light	Indicates continuity with bulb screwed in. 120 VAC. If no voltage is present at light, check wiring or light switches.
JXT8030ADS, JXT8036ADS, JXT8042ADS, JXT8136ADS, JXT8142ADS, JXT5830AD*, JXT5836AD*	Capacitor	Disconnect wires. Measure resistance by placing red meter lead on positive terminal, black meter lead on negative terminal Reverse meter leads on capacitor terminals..... Check for a short by placing one lead on a terminal and the other to ground.....	Meter reading should gradually increase (capacitor charging). Meter reading should gradually decrease (capacitor discharging). Infinity (if shorted, replace capacitor).
JXT9030CDP, JXT9036CDP, JXT9048CDP, JXT9130CDP, JXT9136CDP	Capacitors (2 ea, red wires input, yellow wires output)	Obtain analog multi-meter. Disconnect wires. Measure resistance by placing red meter lead on positive terminal, black meter lead on negative terminal Reverse meter leads on capacitor terminals..... Check for a short by placing one lead on a terminal and the other to ground.....	Rating: 4 microfarad Meter reading should gradually increase (capacitor charging). Meter reading should gradually decrease (capacitor discharging). Infinity (if shorted, replace capacitor).
JXT8030ADS, JXT8036ADS, JXT8042ADS, JXT8136ADS, JXT8142ADS, JXT5830AD*, JXT5836AD*	Transformer	Check for input voltage by placing red lead on black wire (input voltage), black lead on white wire (neutral)..... Check transformer outputs by placing leads on black (input voltage) and white (neutral), then set fan speed as follows: 6 5 4 3 2 1	120 VAC 113 VAC 88 VAC 80 VAC 66 VAC 50 VAC 33 VAC
JXT9030CDP, JXT9036CDP, JXT9048CDP, JXT9130CDP, JXT9136CDP	Transformer	Check for input voltage by placing red lead on brown wire (input), black lead on light blue wire (neutral) Check transformer outputs by placing meter leads on: Brown (Input voltage) Black Red..... Orange Yellow..... Green (Lowest setting)	120 VAC 120 VAC 106 VAC 97 VAC 90 VAC 81 VAC 74 VAC

Testing Procedures



WARNING

To avoid risk of electrical shock, personal injury or death; disconnect power to vent hood before servicing, unless testing requires power.

Model Numbers	Component	Test Procedure	Results
JXT8030ADS, JXT8036ADS, JXT8042ADS, JXT8136ADS, JXT8142ADS, JXT5830AD*, JXT5836AD*	Blower Motor	Check input voltage by placing leads on screws in green connector, black wire terminal (input voltage) and white wire terminal (neutral)..... Measure resistance.....	120 VAC 12 Ω (if under 3 Ω, motor windings shorted. If over 3 Ω but under 7 Ω, capacitor shorted.)
JXT9030CDP, JXT9036CDP, JXT9048CDP, JXT9130CDP, JXT9136CDP	Blower Motor	Check input voltage by placing leads on light blue wire terminal (input voltage) and black wire terminal (neutral)..... Measure resistance.....	120 VAC 16 Ω through both motors
JXT8030ADS, JXT8036ADS, JXT8042ADS, JXT8136ADS, JXT8142ADS, JXT5830AD*, JXT5836AD*	Control Board	Measure input voltage by placing leads on screws in green connector, black wire terminal (input voltage) and white wire terminal (neutral).....	120 VAC
JXT9030CDP, JXT9036CDP, JXT9048CDP, JXT9130CDP, JXT9136CDP	Control Board	Measure input voltage by placing meter leads on black/white wire (input voltage) and white wire (neutral).....	120 VAC
JXT8030ADS, JXT8036ADS, JXT8042ADS, JXT8136ADS, JXT8142ADS, JXT5830AD*, JXT5836AD*	Control Panel	Measure input voltage by placing leads on screws in green connector, black wire terminal (input voltage) and white wire terminal (neutral).....	120 VAC, if not, replace Control Panel
JXT9030CDP, JXT9036CDP, JXT9048CDP, JXT9130CDP, JXT9136CDP	Touch Pad <i>Pin 1 = Black wire,</i> <i>Pin 2 = Brown wire,</i> <i>Pin 3 = Red wire,</i> <i>Pin 4 = Orange wire,</i> <i>Pin 5 = Yellow wire,</i> <i>Pin 6 = Green wire,</i> <i>Pin 7 = Blue wire,</i> <i>Pin 8 = Violet wire</i>	Remove multi-colored display cable from control board, place meter leads on the applicable pins, press the applicable pad and measure resistance. Pins 2 & 5, turn on Light On/Off Pins 2 & 6, turn on Fan On/Off Pins 3 & 5, press & hold Fan Speed + Pins 3 & 6, press & hold Fan Speed - Pins 4 & 5, press & hold Delay Off	Continuity Continuity Continuity Continuity Continuity

Disassembly Procedures



To avoid risk of electrical shock, personal injury or death; disconnect power to unit before servicing.

Disassembly for models JXT9030CDP,
JXT9036CDP, JXT9048CDP, JXT9130CDP,
JXT9136CDP

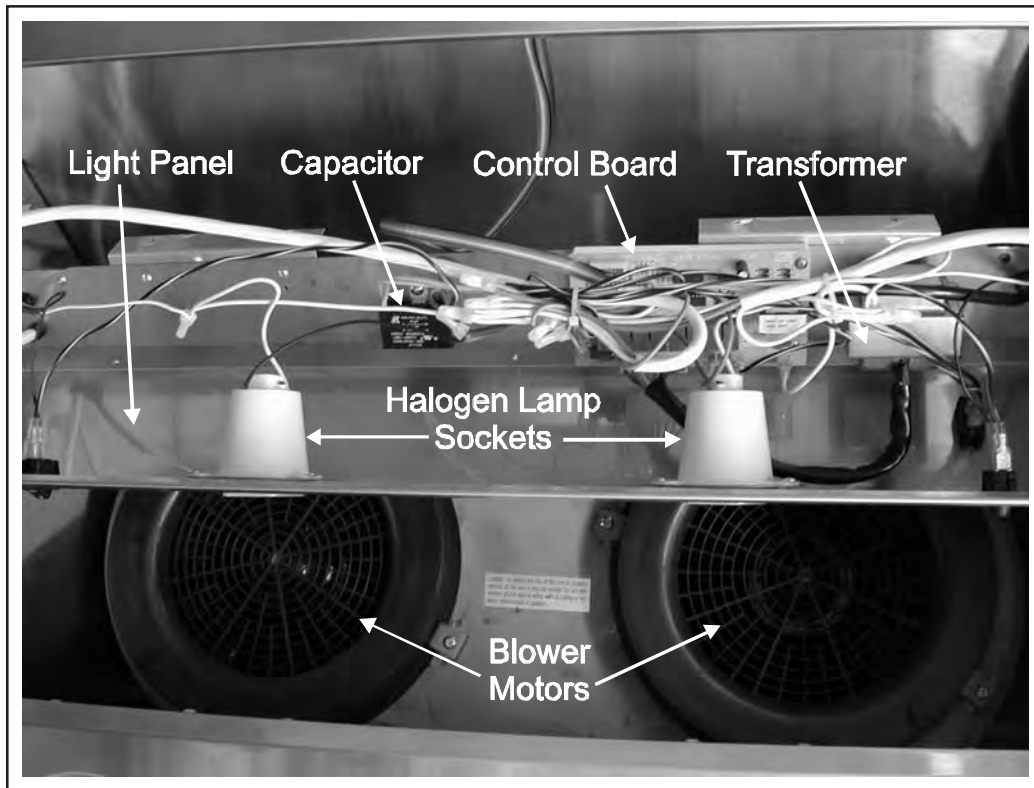

Halogen Light Removal

1. Turn off power to the light bulb.
2. Twist light bulb counterclockwise from the socket.

NOTE: A suction cup may be required for light bulb removal. One may be obtained from a local hardware store.

3. Reverse procedure to reinstall light bulb.

Heat Lamp Removal

1. Turn off power to the heat lamp.
2. Twist heat lamp counterclockwise from the socket.

NOTE: A suction cup may be required for heat lamp removal. One may be obtained from a local hardware store.

3. Reverse procedure to reinstall heat lamp.

Grease Filter/Grease Filter Cover Removal

1. Turn off power to the blower motors.
2. Remove grease filter covers by using handles and pulling filter cover toward the rear of the vent hood.
3. Pivot front of grease filter upward, then pull the filter downwards and toward the rear to remove.
4. Reverse procedure to reinstall grease filters and grease filter covers.

Halogen Light Socket Removal

1. Disconnect power to vent hood.
2. Remove halogen light, see "Halogen Light Removal" procedure.
3. Remove grease filters and covers, see "Grease Filter/Grease Filter Cover Removal" procedure.
4. Remove light panel, see "Light Panel Removal" procedure.
5. Remove screws securing light socket and remove light socket.
6. Reverse procedure to reinstall light socket.

Heat Lamp Socket Removal

1. Disconnect power to vent hood.
2. Remove heat lamp, see "Heat Lamp Removal" procedure.
3. Remove grease filters and covers, see "Grease Filter/Grease Filter Cover Removal" procedure.
4. Remove screw securing electrical connector cover.
5. Label and disconnect heat lamp socket electrical connection.
6. Remove screws securing lamp reflector.
7. Remove screws securing lamp socket and remove lamp socket.
9. Reverse procedure to reinstall lamp socket.

Disassembly Procedures



To avoid risk of electrical shock, personal injury or death; disconnect power to unit before servicing.

Light Panel Removal

1. Disconnect power to vent hood.
 2. Remove grease filters and covers, see "Grease Filter/ Grease Filter Cover Removal" procedure.
 3. Remove screws securing light panel.
- NOTE:** Some screws are located on top of light panel.
4. Remove screws securing blower motor cover.
 5. Label and disconnect fan switch wires.
 6. Remove light socket, see "Light Socket Removal" procedure.
 7. Angle the light panel slightly and gently pull down to remove from vent hood.
 8. Reverse procedure to reinstall light panel.



Control Board Removal

1. Disconnect power to vent hood.
2. Remove grease filters and covers, see "Grease Filter/ Grease Filter Cover Removal" procedure.
3. Remove screws securing light panel.
4. Slide panel towards rear of vent hood.
5. Remove light panel, see "Light Panel Removal" procedure.
6. Label and disconnect control board wiring and remove control board.
7. Reverse procedure to reinstall control board.

Capacitor Removal

1. Disconnect power to vent hood.
2. Remove grease filters and covers, see "Grease Filter/ Grease Filter Cover Removal" procedure.
3. Remove light panel, see "Light Panel Removal" procedure.
4. Discharge capacitor by connecting a one end of a jumper wire to the capacitor terminal with the diode connection and the other end to a well insulated screwdriver. Touch the screwdriver to a chassis ground. Remove jumper wire.
5. Remove screws securing capacitor.
6. Label and disconnect capacitor electrical connections and remove capacitor.
7. Reverse procedure to reinstall capacitor.

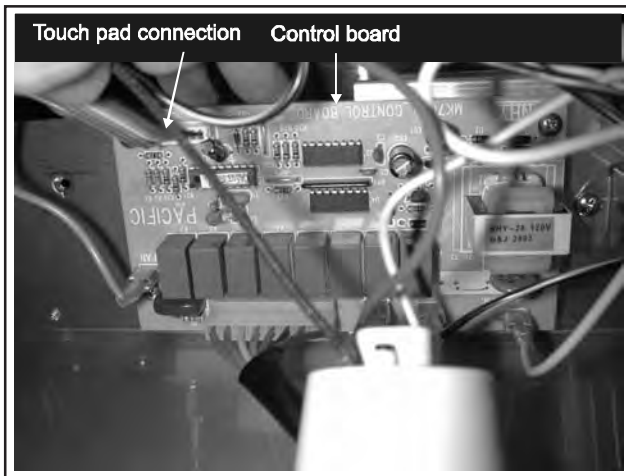

Touch Pad Removal

1. Disconnect power to vent hood.
2. Remove grease filters and covers, see "Grease Filter/ Grease Filter Cover Removal" procedure.
3. Remove light panel, see "Light Panel Removal" procedure.
4. Remove screws securing touch pad.
5. Label and disconnect touch pad electrical connections.
6. Rotate and remove touch pad from base.
7. Reverse procedure to reinstall touch pad.

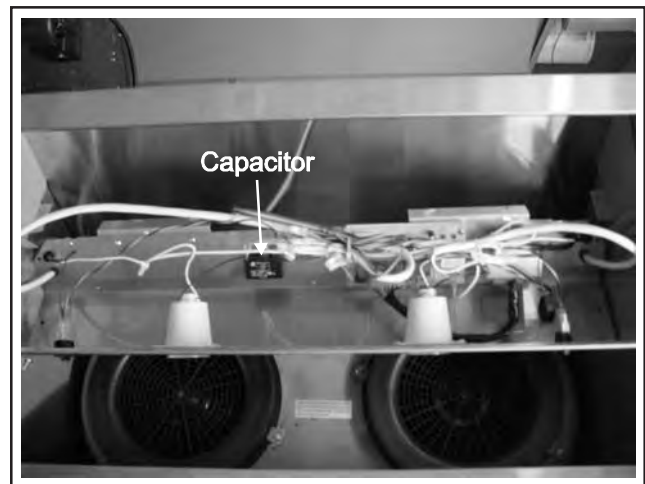

Disassembly Procedures



To avoid risk of electrical shock, personal injury or death; disconnect power to unit before servicing.

Transformer Removal

1. Disconnect power to vent hood.
2. Remove grease filters by using handles and pulling filter toward the rear of the vent hood.
3. Pivot front of filter upward, then pull the filter downwards and toward the rear to remove.
4. Remove light panel, see "Light Panel Removal" procedure.
5. Discharge capacitor by connecting a one end of a jumper wire to the capacitor terminal with the diode connection and the other end to a well insulated screwdriver. Touch the screwdriver to a chassis ground. Remove jumper wire.
6. Remove screws securing transformer.
7. Label and disconnect transformer electrical connections.
8. Remove transformer.
9. Reverse procedure to reinstall transformer.

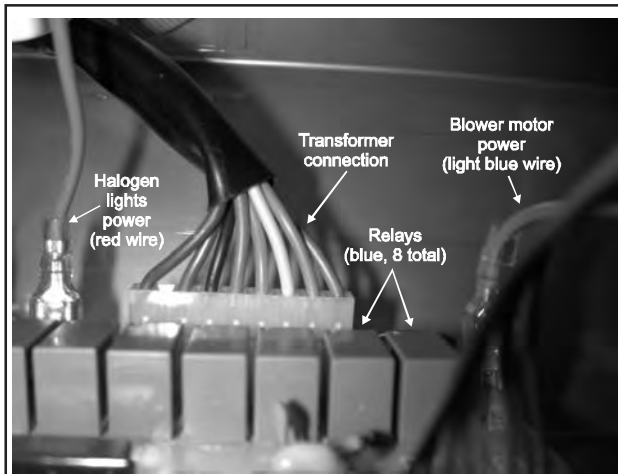
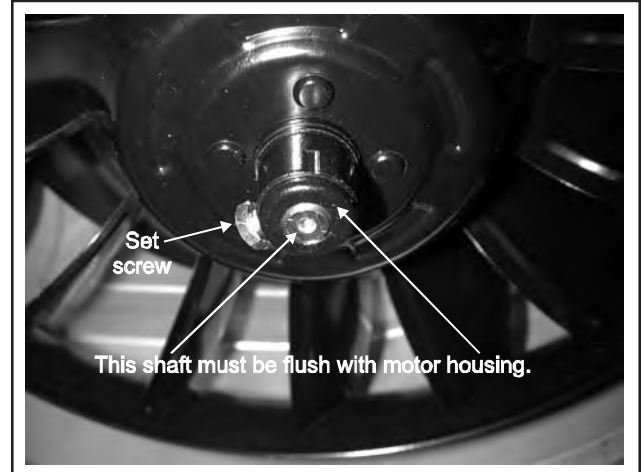

Filter Spring Clip Removal

1. Disconnect power to vent hood.
2. Remove grease filters and covers, see "Grease Filter/ Grease Filter Cover Removal" procedure.
3. Locate and remove clip assemblies installed in vent housing by gently pulling clip toward the front and up.
4. Reverse procedure to reinstall the filter spring clip.

Blower Motor Removal

1. Disconnect power to vent hood.
2. Remove grease filters and covers, see "Grease Filter/ Grease Filter Cover Removal" procedure.
3. Remove screws securing blower motor covers.
4. Remove blower wheel hub assembly.
5. Loosen set screws and remove blower motor wheel.
6. Remove screws securing blower motor to vent hood.
7. Label and disconnect blower motor electrical connections.
8. Rotate blower motor counterclockwise to remove.
9. Reverse procedure to reinstall blower motor.

NOTE: When reinstalling motor, ensure washers removed in Step 6 are installed over edge of blower motor housing.

NOTE: When reinstalling motor, ensure blower motor shaft is flush with blower motor bushing.

Disassembly Procedures



WARNING

To avoid risk of electrical shock, personal injury or death; disconnect power to unit before servicing.

Disassembly for models JXT8042ADS,
JXT8142ADS, JXT5830AD*, JXT5836AD*

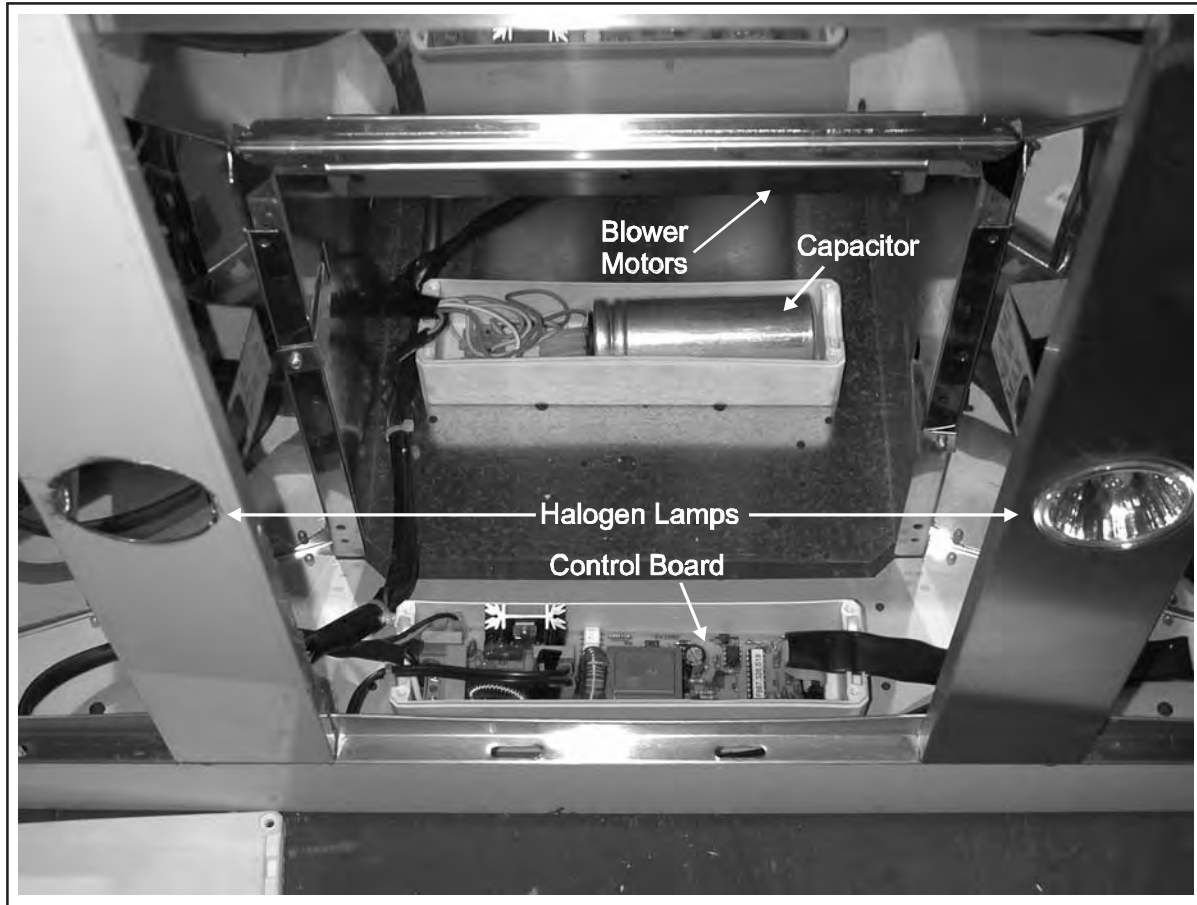

Halogen Light Removal

1. Turn off power to the light bulb.
2. Twist light bulb counterclockwise from the socket.

NOTE: A suction cup may be required for light bulb removal. One may be obtained from a local hardware store.

3. Reverse procedure to reinstall light bulb.

Halogen Light Socket Removal

1. Disconnect power to vent hood.
2. Remove halogen light, see "Halogen Light Removal" procedure.
3. Remove grease filters and covers, see "Grease Filter/Grease Filter Cover Removal" procedure.
4. Remove light panel, see "Light Panel Removal" procedure.
5. Remove screws securing light socket and remove light socket.
6. Reverse procedure to reinstall light socket.

Grease Filter/Grease Filter Cover Removal

1. Turn off power to the blower motors.
2. Remove grease filter covers by using handles and pulling filter cover toward the rear of the vent hood.
3. Pivot front of grease filter upward, then pull the filter downwards and toward the rear to remove.
4. Reverse procedure to reinstall grease filters and grease filter covers.

Control Board Removal

1. Disconnect power to vent hood.
2. Remove center grease filter.
3. Remove screws securing center vent hood cover.
4. Remove screws securing vent hood control cover.
5. Remove vent hood control cover.
6. Slide control board out, label and disconnect wires.
7. Remove control board.
8. Reverse procedure to reinstall control board.

Disassembly Procedures



To avoid risk of electrical shock, personal injury or death; disconnect power to unit before servicing.

Control Panel Removal

1. Disconnect power to vent hood.
2. Remove screws securing top retractable cover.
3. Slide cover down to gain access to the support rods.

NOTE: Insert a prop rod under the vent hood before performing step 4. Once the support rod screws are removed, the vent hood will lower.

4. Remove screws securing cover to support rods.
5. As the vent hood lowers, label and disconnect electrical connections and the ducting.
6. Remove grease filters and covers, see "Grease Filter/ Grease Filter Cover Removal" procedure.
7. Remove screws securing all vent hood covers.
8. Remove screws securing control panel assembly.

NOTE: A small, square-type wrench is necessary to remove screws.

9. Remove screws securing vent hood canopy to base.
10. Remove screws securing control panel to base.
11. Label and disconnect control panel connections.
12. Rotate and remove control panel from base.
13. Reverse procedure to reinstall control panel.

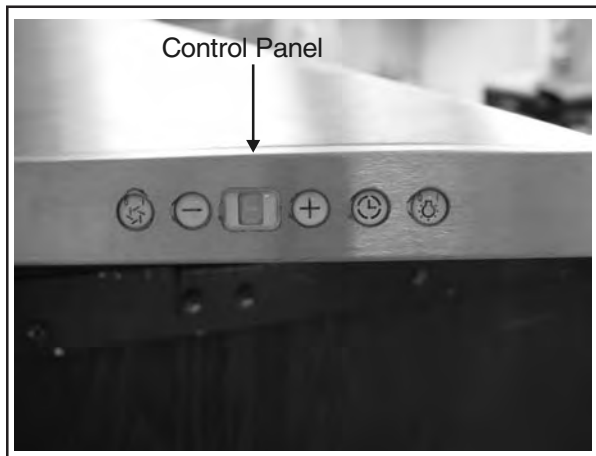

10. Label and disconnect blower electrical connections and remove blower motor.

11. Reverse procedure to reinstall blower motor.

NOTE: When reinstalling motor, ensure washers removed in Step 9 are installed over edge of blower housing.

Capacitor Removal

1. Disconnect power to vent hood.
2. Remove grease filters and covers, see "Grease Filter/ Grease Filter Cover Removal" procedure.
3. Remove screws securing capacitor cover.
4. Discharge capacitor by connecting a one end of a jumper wire to the capacitor terminal with the diode connection and the other end to a well insulated screwdriver. Touch the screwdriver to a chassis ground. Remove jumper wire.
5. Remove screws securing capacitor cover.
6. Label and disconnect capacitor electrical connections and remove capacitor.
7. Reverse procedure to reinstall capacitor.

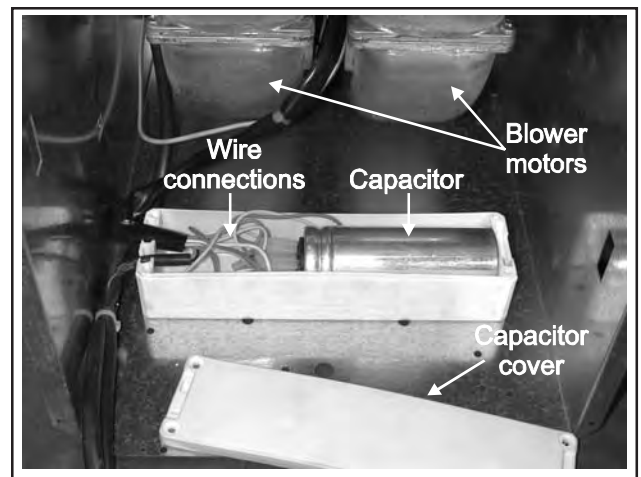

Blower Motor Removal

1. Disconnect power to vent hood.
2. Remove screws securing top retractable cover.
3. Slide cover down to gain access to the support rods.

NOTE: Insert a prop rod under the vent hood before performing step 4. Once the support rod screws are removed, the vent hood will lower.

4. Remove screws securing cover to support rods.
5. As the vent hood lowers, label and disconnect electrical connections and ducting.
6. Remove grease filters and covers, see "Grease Filter/ Grease Filter Cover Removal" procedure.
7. Remove screws securing all vent hood covers.
8. Remove control panel, see "Control Panel Removal" procedure.
9. Disengage supports from side of motor.

Filter Spring Clip Removal

1. Disconnect power to vent hood.
2. Remove grease filters and covers, see "Grease Filter/ Grease Filter Cover Removal" procedure.
3. Locate and remove clip assemblies installed in vent housing by gently pulling clip toward the front and up.
4. Reverse procedure to reinstall the filter spring clip.

Appendix A

INSTALLATION

MOUNTING THE RANGEHOOD

1. This range hood is mounted under a kitchen cabinet unit.
2. Select preferred duct location on rear or top of unit. For ductless conversion, no ducting is required, however front cover panel must be removed prior to installation. (See page 7)
3. An optional spacer plate is provided to cover the gap between the back of the hood and the wall. If using this plate, screw it onto the hood prior to installation.
4. Begin installation by temporarily removing the mesh filter panels.
5. Unscrew the two interior side panels and slide them sideways to allow access for marking the mounting hole locations. (See page 7)
6. Temporarily position the range hood in the desired mounting location.
7. Mark the mounting holes, duct and electrical access locations with a pencil. For ductless conversion, no hole is required for a duct.
8. Drill/cut out the required openings for duct and electrical access.
9. Install duct work and electrical.
10. Fasten mounting screws into underside of mounting location, and reposition hood into place.
11. Hang hood onto mounting screws and hand tighten.

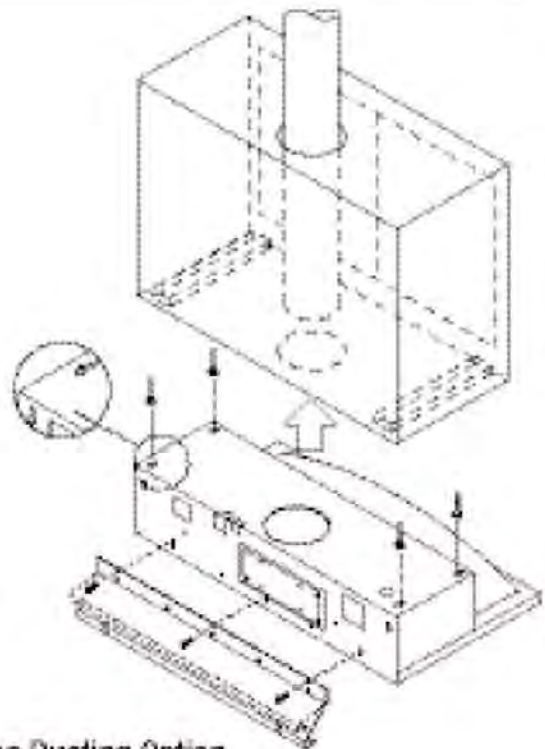

Top Ducting Option

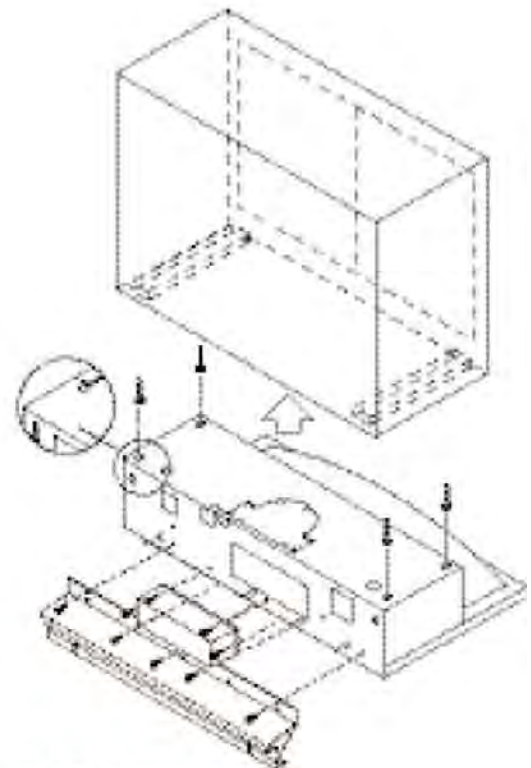

Rear Ducting Option

Installation Instructions (JXT8030ADS, JXT8036ADS, JXT8042ADS)

INSTALLATION

SPECIFICATIONS

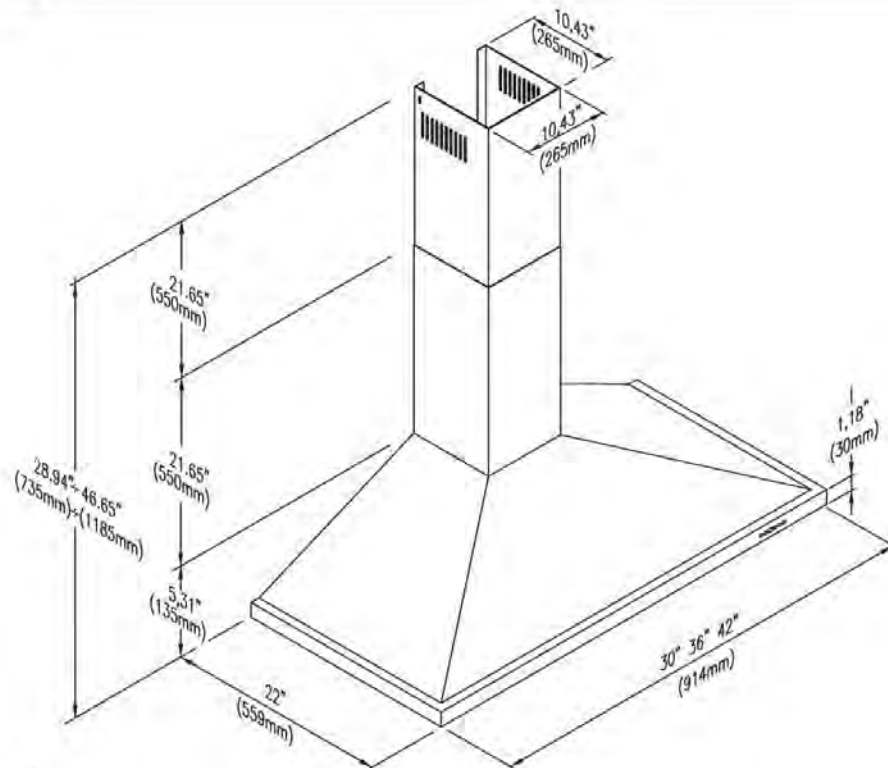

ELECTRICAL



All Electrical work must be performed by qualified electrician or person with similar technical know how and background.

For personal safety, remove house fuse or open circuit breaker before beginning installation. Do not use extension cord or adapter plug with this appliance.

Follow National electrical codes or prevailing local codes and ordinances.

Electrical Supply:

This appliance requires a 120V 60Hz electrical supply, and connected to an individual, properly grounded branch circuit, protected by a 15 or 20 ampere circuit breaker or time delay fuse. Wiring must be 2 wire w/ ground. Please also refer Electrical Diagram labeled on product.

Cable Lock:

A cable locking connector (not supplied) might also be required by local codes. Check with local requirements and codes, purchase and install appropriate connector if necessary.

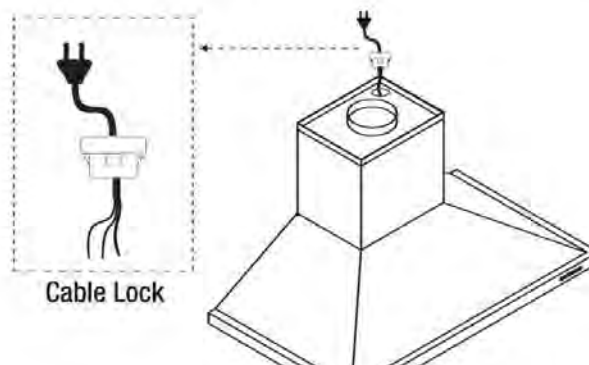

INSTALLATION

MOUNTING THE RANGEHOOD

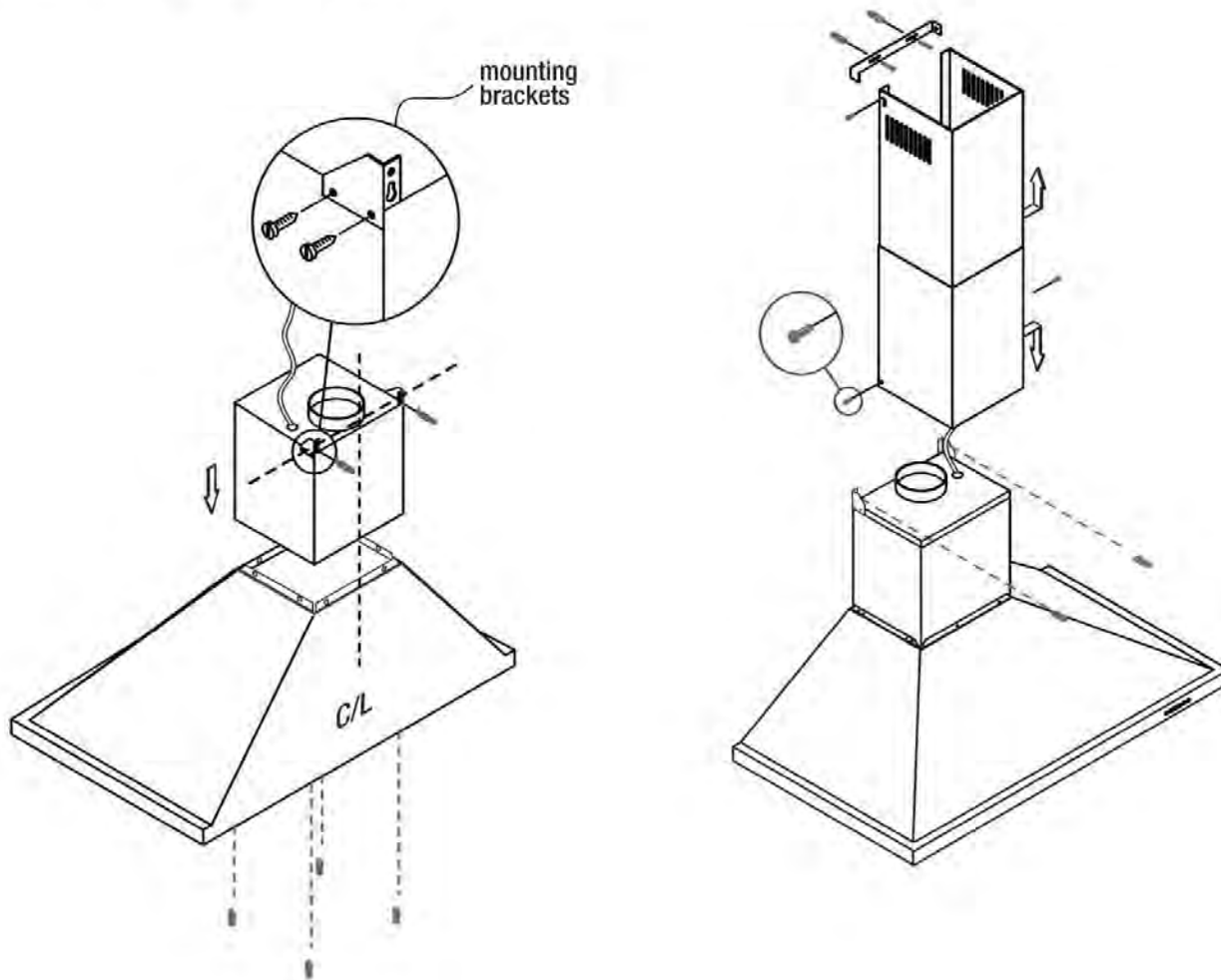

1. Screw mounting brackets onto left and right side of blower unit.
2. Attach blower to canopy, fasten with screws from below.
3. Determine hood height, center, mark, level and hang hood to wall through mounting keyholes on back.
4. Install duct work and electrical.
5. Locate and fasten bracket for upper telescopic duct cover onto the wall.
6. Slip upper and lower telescopic duct covers onto top of blower and screw in place.
7. Secure hood to wall studs whenever possible; use appropriate wall fasteners & hardware (not supplied) for hollow drywall, tiled, concrete, brick wall applications for mounting hood.

Note: Butterfly damper may be installed by placing it on top of the motor housing.

Installation Instructions (JXT8136ADS, JXT8142ADS)

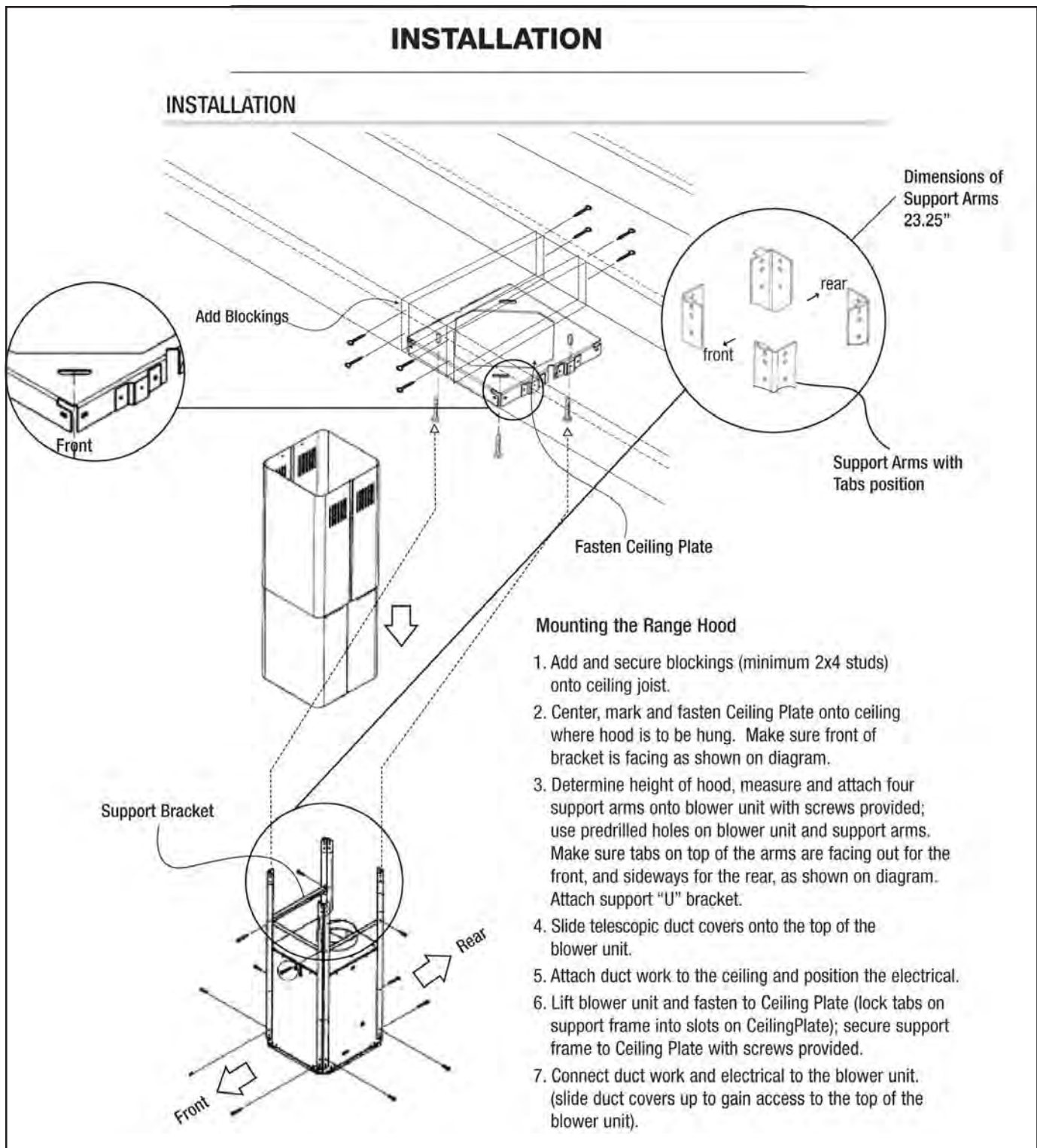

Installation Instructions (JXT8136ADS, JXT8142ADS)

INSTALLATION

INSTALLATION

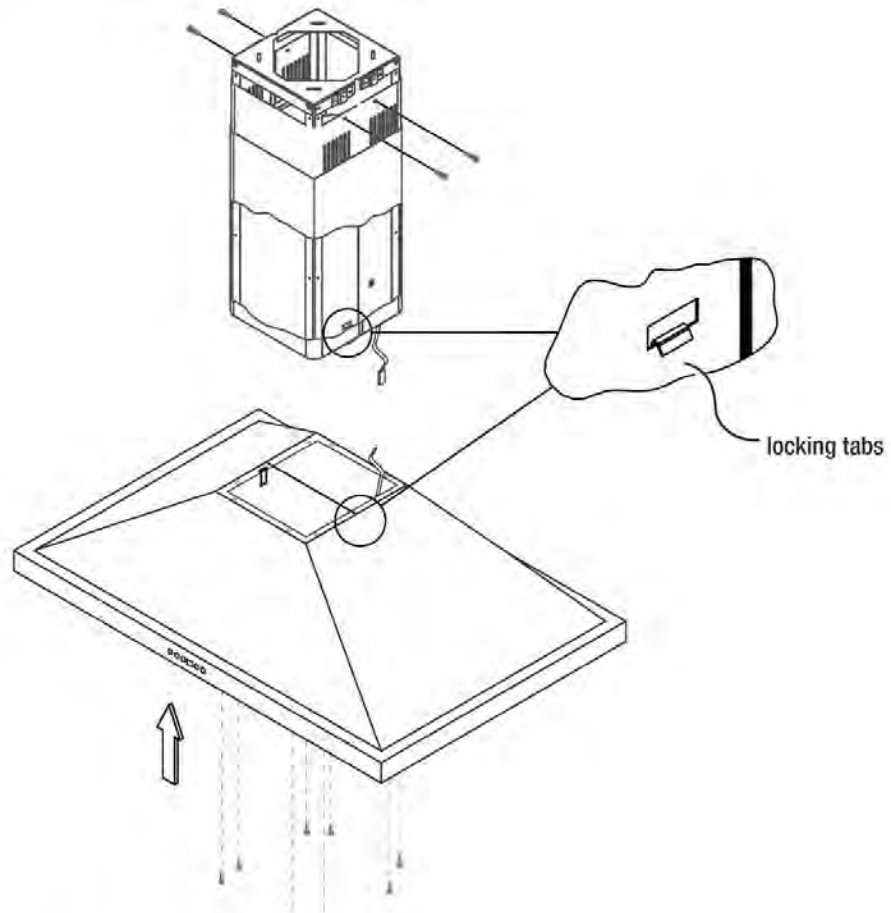

Mounting the Range Hood

8. Lift canopy and snap locking tabs into blower unit.
9. Fasten canopy to blower with screw provided from inside of canopy.
10. Push telescopic duct section up in place and fasten.

Note: Butterfly damper may be installed by placing it ontop of the motor housing.

INSTALLATION

MOUNTING THE RANGEHOOD

1. Begin by determining hood mounting height on wall.

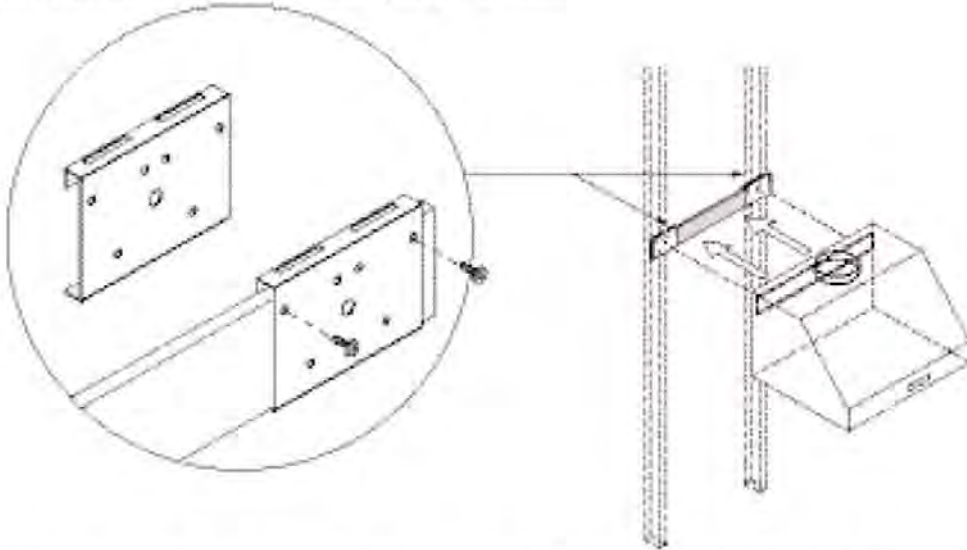

2. Level and mount the wood panel onto the wall at the appropriate height and secure it to the studs. This wood panel should be 1/2" x 3" and the width will either be 29", 35" or 47" depending on the width of the hood. Measure the distance between the wall mounting brackets and fasten them onto the wood panel. Refer to the diagram for how the brackets attach to the panel. Make sure they will line up with the brackets on the back of the hood. Lift the hood and hang it onto the brackets.
3. Temporarily remove the baffle filters from hood, and level hood by adjusting the metal brackets located inside of the hood. (Note: there is approximately 10cm total adjustability up and down). These brackets are adjusted by a screw that can be easily turned with your fingers. There is one on each side on the inside back wall of the hood. After ensuring that the hood is level, completely tighten the screws to secure the hood to the wall.
4. After the hood is attached to the mounting brackets, you may further secure it by screwing two screws into the wall from the inside of the hood. There are two screw holes near the bottom that you can use as a guide.

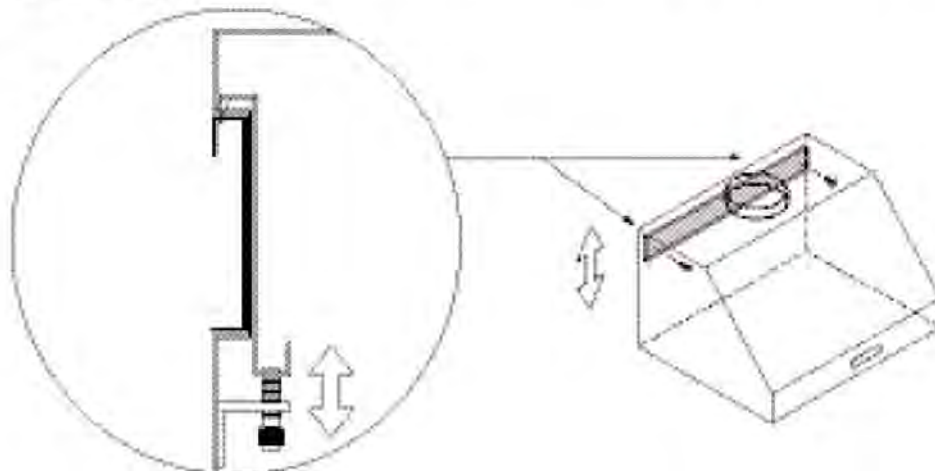

INSTALLATION

MOUNTING THE RANGEHOOD

5. Install electrical.
6. Install duct work and tape all joints.
7. Power up hood and check for leaks around duct joints, and if necessary apply more duct tape.

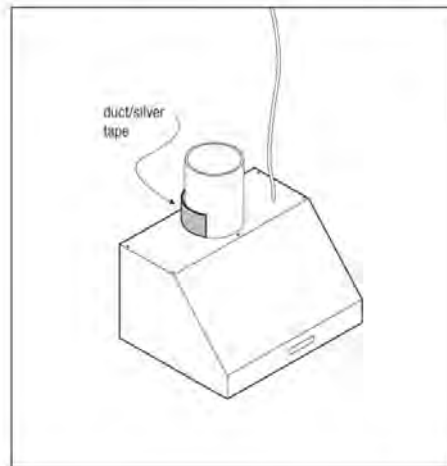

8. Install optional duct cover and/or backsplash. Note that the duct cover and backsplash are sold separately.
9. Reinstall the baffle filters.

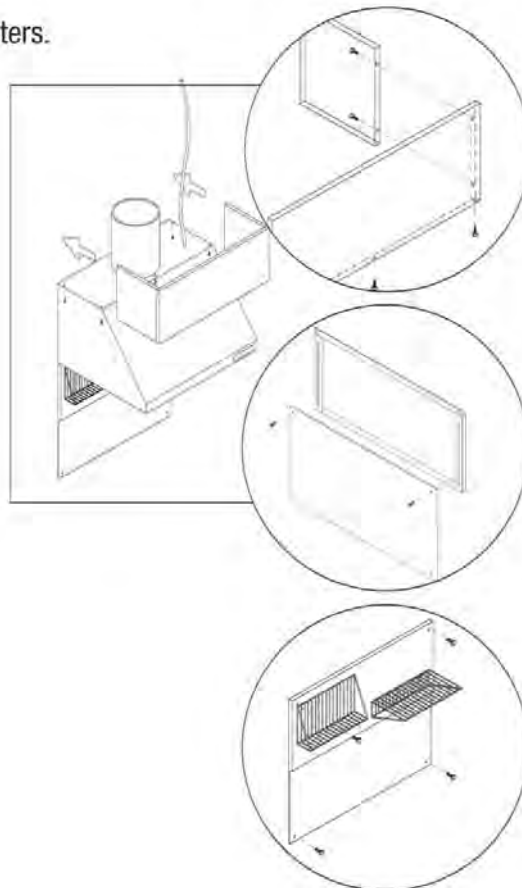

Installation Instructions (JXT9130CDP, JXT9136CDP)

INSTALLATION

MOUNTING HEIGHTS

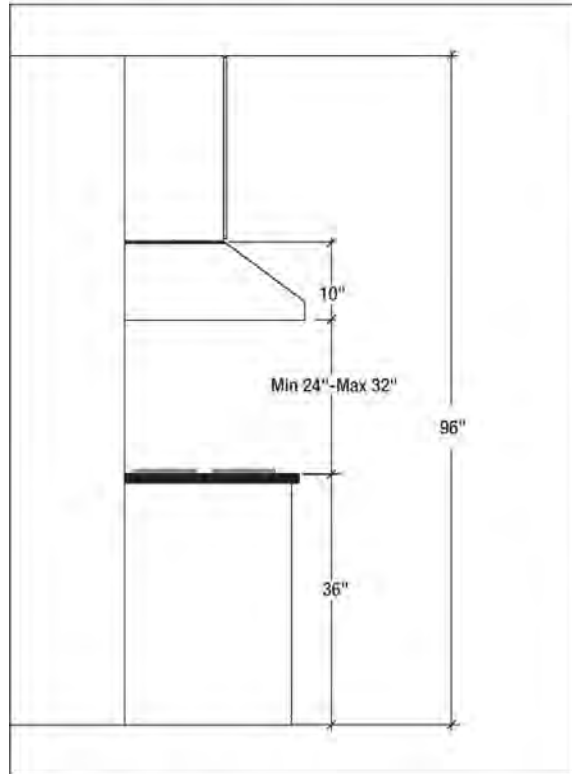

Minimum mount height between range top to hood bottom should be no less than 24".

Maximum mount height should be no higher than 32".

It is important to install the hood at the proper mounting height. Hoods mounted too low could result in heat damage and fire hazard; while hoods mounted too high will be hard to reach and will lose its performance and efficiency.

If available, also refer range manufacturer's height clearance requirements and recommended hood mounting height above range.

DUCTING

A minimum of 6" round or 3-1/4" x 10" rectangular duct must be used to maintain maximum air flow efficiency.

Always use rigid type metal ducts only. Flexible ducts could restrict air flow by up to 50%.

Also use calculation (on right) to compute total available duct run when using elbows, transitions and caps.

ALWAYS, when possible, reduce the number or transitions and turns. If long duct run is required, increase duct size from 6" to 7 or 8". If a reducer is used, install a long reducer instead of a pancake reducer. Reduce duct size as far away from opening as possible.

If turns or transitions are required: Install as far away from opening and as far apart, between 2, as possible.

Minimum Duct Size:

Round:
6" minimum
Rectangular:
3-1/4" x 10"

Duct Run Calculation:

Maximum run

6" or 3-1/4" x 10" duct	100 FT
Deduct:	
each 90 Elbow used	15 FT
each 45 elbow used	9 FT
each 6" to 3/14 x 10" transition used	1 FT
each 3/14 x 10" to 6" transition used	5 FT
Side Wall Cap w/ damper	30 FT
Roof Cap	30 FT

e.g. - 1 roof cap, 2x90 elbows, 1 x 45 elbow used:
=30' + 30' + 9' =69' used, 31' available for straight duct runs.

INSTALLATION

MOUNTING THE RANGEHOOD

1. This range hood is mounted under a kitchen cabinet unit.
2. Select preferred duct location on rear or top of unit. (See page 6 & 7 for ducting conversion options)
3. Begin installation by temporarily removing the baffle filters.
4. Reinforce cabinet base with 1x2 wood strips if additional strengthening is required.
5. Temporarily position the range hood in the desired mounting location. Measure and mark the mounting holes, duct and electrical access locations with a pencil.
6. Drill/cut out the required openings for duct and electrical access; make sure the duct opening is large enough to apply duct tape.
7. Fasten hood onto cabinet with screws and washers provided.
8. Install electrical.
9. Install duct work and duct-tape.
10. Reinstall the baffle filters.
11. Power up hood and check for leaks around duct-tape.

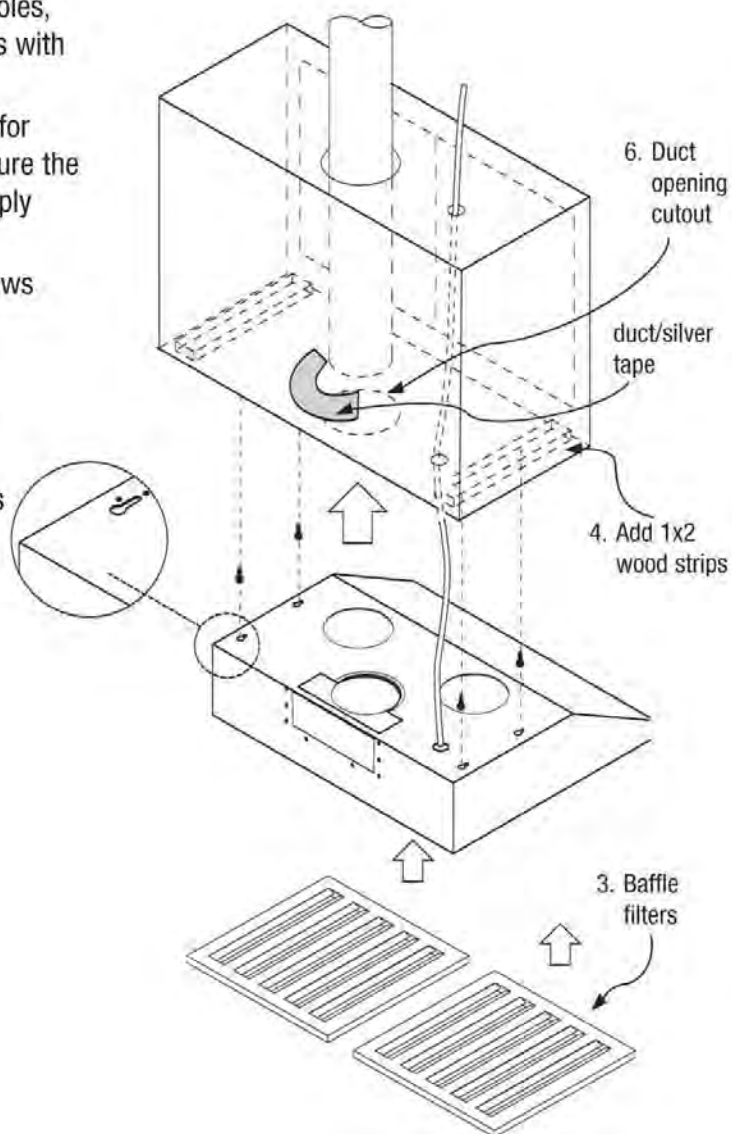

Appendix B

Use Information (JXT583*AD*, JXT803*ADS, JXT8042ADS, JXT8136ADS, JXT8142ADS)

CONTROLS & FEATURES

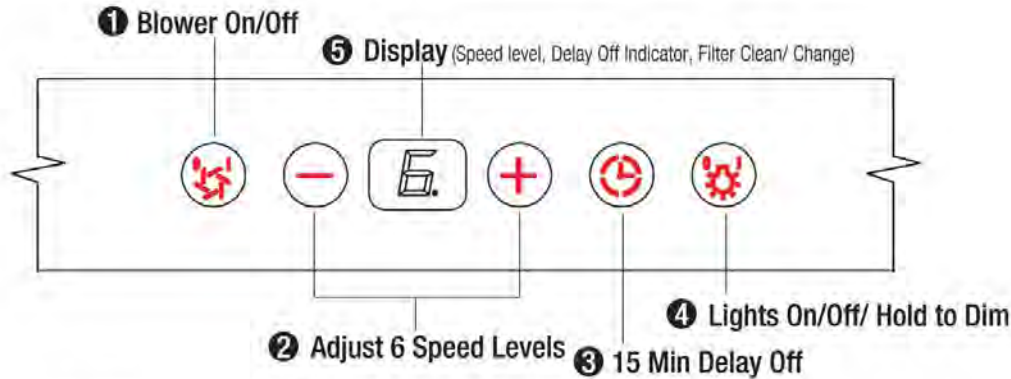

TOUCH CONTROLS & FEATURES





① Blower On/Off

By pressing , the blower is switched On and Off. When switched on, the blower starts up on speed level 3.



② Speed Selection

The 6 speed levels are selected by pressing  to decrease and  to increase speed level. The display indicates level selected.

③ Delay Off

This is used for programmed shut down of blower and lights 15 minutes after the function is activated. Press  once, a dot flashes in the lower right hand side of display  indicating the function is on. The hood will completely shut down in 15 minutes.

④ Lights On/Off/ Dim

Switch lights On and Off by pressing key  once. To dim lights, press and hold  for 2 seconds.

⑤ Advance Display Functions

Filter Clean Reminder (Metal):

After every 30 hours of use, the display will start flashing an  reminding you to clean the metal filters for residue and possible clogs.

The standard Metal Filters are required to be cleaned frequently and as recommended in order to maintain blower efficiency. If improperly maintained, residue from cooking will sift through filters and cause damage to hood blowers and other sensitive components; and possibly clog duct work and create a fire hazard.



CONTROLS & FEATURES

CONTROLS: FILTER CHANGE INDICATOR (CARBON FILTERS)

Filter Change Reminder (Carbon, if fitted):

When your hood is installed as a 'Purifying' (Ductless Recirculating) unit, it is fitted with a set of Carbon Filters to purify exhaust and fumes from cooking, then re-circulate the air within the home. These Carbon Filters are required to be replaced after every 120 hours of use. The **Filter Change Reminder** function in the microprocessor needs to be switched on. The microprocessor in the controls when set, will elapse and count usage time and indicate by a flashing  when carbon filter replacement is needed.

Setting the Filter Change Reminder:

When Off, hold  for approx. 5 seconds. The display will change from  (exhaust mode) to , (purifying mode/ carbon filters used) this indicates that the elapse timer function is switched on and Carbon Filters are used.

Set Mode

hold 5 secs.



display from <--> to <C>



Filter Replace Indicator:



When the display  starts flashing, the Carbon Filters require replacement.

Change Filters

display <C> flashes



Re-setting Function:

Once filters are replaced, with hood off, press and hold , the display will appear; hold for approximately 5 seconds until  on display disappears . The Filter Change Reminder is now re-set and a new 120 hours elapse cycle is initiated.

To Reset

hold 5 secs.



display from <C> to < >



Use Information (JXT583*AD*, JXT803*ADS, JXT8042ADS, JXT8136ADS, JXT8142ADS)

CONTROLS & FEATURES

CONTROLS: FILTER CLEAN INDICATOR (METAL FILTERS)

Filter Clean Reminder (Standard Metal Filters fitted)

Whether your hood is installed as an Exhaust or Purifying unit, a set of metal filters are fitted by the factory. These Metal Filters are intended to filter out residue from cooking. They need not be replaced on a regular basis but are required to be kept clean. The **Filter Change Reminder** function in the microprocessor will automatically indicate by a flashing  when the metal filters need to be cleaned after every 30 hrs. of use. Filters can be cleaned by hand with non-abrasive soap or in a dishwasher. Heavily soiled filters should also be soaked in grease cutting detergent such as Formula '409' or its equivalent, prior to cleaning.

Filter Clean Reminder:

When  flashes on display, the metal filters installed are required to be cleaned. This will occur after every 30 hours of use.

Clean Filters

display <A> flashes



Re-setting Function:

Reset the Filter Clean Reminder timer when filters are cleaned and re-installed. Press and hold  for approx. 5 seconds, the display will appear; hold for approximately 5 seconds until  on display disappears . The Filter Clean Reminder function is now re-set and a new 30 hours elapse cycle is initiated.

To Reset

hold 5 secs.



display from <C> to < >









Use Information (JXT903*CDP, JXT9048CDP, JXT913*CDP)

CONTROLS & FEATURES

CONTROLS & FEATURES

The diagram shows a control panel with several buttons. From left to right: a clock icon (3), a minus sign (2), six small circles (2), a plus sign (2), a power icon (1), and a light bulb icon (4). Lines connect these icons to numbered callouts: 1 points to the power icon, 2 points to the minus and plus signs, 3 points to the clock icon, and 4 points to the light bulb icon.

- 1 Blower On/Off**
By pressing , the blower is switched On and Off.
- 2 Speed Selection**
The 6 speed levels are selected by pressing  to decrease and  to increase speed level. The display indicates level selected.
- 3 Delay Off**
This is used for programmed shut down of blower and lights 15 minutes after the function is activated. After pressing , the hood will completely shut down in 15 minutes.
- 4 Lights On/Off/Dim**
Switch lights On and Off by pressing  once. To dim lights, press and hold  for 2 seconds.

Care and Cleaning (all)

Surface

Clean periodically with hot soapy water and clean cotton cloth. Do not use corrosive or abrasive detergent (e.g. Comet powder scrub, EZ-Off oven cleaner), or steel wool/scouring pads which will scratch and damage surface.

For heavier soil use liquid degreaser such as "Formula 409" or "Fantastic" brand cleaner.

After cleaning, you may use non-abrasive stainless steel polish/ cleaners such as 3M or ZEP, to polish and buff out the stainless luster and grain. Always scrub lightly, with clean cotton cloth, and with the grain. Do not use any product containing chlorine bleach. Do not use "orange" cleaners.

Metal Filters

The Metal Filters fitted by the factory are intended to filter out residue and grease from cooking. They need not be replaced on a regular basis but are required to be kept clean. Filters should be cleaned after every 30 hours of use. Use the Filter Clean Reminder function on the controls to determine when filters require cleaning.

Remove and clean by hand or in dishwasher. Spray 'Formula 409' or equivalent degreasing detergent and leave to soak if heavily soiled.

Dry filters and re-install before using hood.

Stainless Steel Baffled Filters

The stainless steel baffled filters fitted by the factory are intended to trap residue and grease from cooking. Although the filters never need replacement, they are required to be kept clean. Filters should be cleaned after every 30 hours of use.